

# 6" TOP DRIVE PORTABLE AUGERS

## OWNER'S & OPERATOR'S MANUAL

Effective September 5, 2015

Publication No. 1015078

THIS MANUAL IS FOR AUGERS WITH SERIAL NUMBERS OF 930955 OR HIGHER

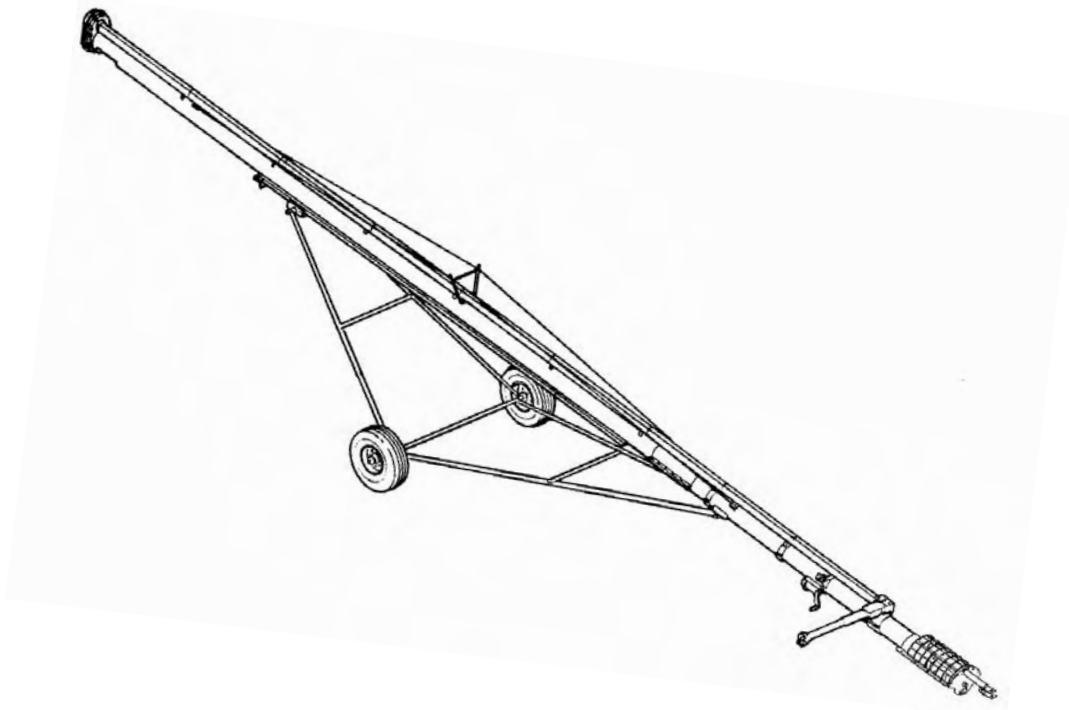

**Hutchinson/Mayrath**

A Division of **GLOBAL** Industries Inc.

Hutchinson/Mayrath • P.O. Box 629 • Clay Center, KS. 67432  
Ph. 785-632-2161 • Fx. 785-632-5964 • Toll Free 800-523-6993  
[www.hutchinson-mayrath.com](http://www.hutchinson-mayrath.com)



## **Hutchinson/Mayrath**

A Division of **GLOBAL** Industries, Inc.

### **POLICIES AND PROCEDURES**

- Prices:** Prices in effect at time of shipment will apply. Prices are subject to change without notice. All prices are F.O.B. Clay Center, Kansas. Orders shipped from locations other than Clay Center, Kansas will be subject to additional charges, such as back freight and/or additional freight.
- Service Charge:** A service charge will be assessed for all past due balances as permitted by state law not to exceed 1-1/2% per month.
- Minimum Order:** Processing and handling costs necessitate a minimum charge of \$15.00 net on all orders.
- Back Orders:** Back orders will be shipped as they become available. Contact Hutchinson/Mayrath Customer Service for alternative shipping options or if cancellation is desired.
- Damaged Goods:** It is the consignee's responsibility to check all shipments thoroughly upon receipt of goods. If any damage is discovered, it must be noted on the freight bill of lading before signing. The consignee must make necessary claims against the respective freight line. All damage claims must be submitted within 30 days of delivery receipt.
- Shortages:** All shortages must be noted at time of delivery. Shortages must be noted on the freight bill of lading before signing. Hutchinson/Mayrath must be advised of all concealed shortages upon discovery. Once notified of concealed shortages Hutchinson/Mayrath will advise corrective action to be taken.
- Return of Goods:** All returns must be approved by Hutchinson/Mayrath prior to shipment. All return requests will be issued a return authorization number. **NO RETURNS WILL BE ACCEPTED WITHOUT A RETURN AUTHORIZATION NUMBER AND PRIOR AUTHORIZATION FROM THE FACTORY.** All returns must be shipped prepaid. A 15% restocking charge will be applied to all returned merchandise. Custom Products may not be returned for credit. Only current products in new and salable condition may be returned. No safety devices may be returned for credit.
- Modifications:** It is the policy of Hutchinson/Mayrath to improve its product whenever possible and practical to do so. We reserve the right to make changes, improvements and modifications at any time without incurring the obligation to make such changes, improvements and modifications on any equipment sold previously.
- Limited Warranty:**
- (a) For a period of (1) year after receipt of goods by the original consumer buyer, Hutchinson/Mayrath will supply free of charge replacement parts for parts that prove defective in workmanship or material. Defective parts must be returned freight prepaid to a specified Hutchinson/Mayrath location. Only Hutchinson/Mayrath original repair parts may be used for warranty repairs.
  - (b) This limited warranty does not extend to parts designed to wear in normal operation and be replaced periodically; or to damage caused by negligence, accident, abuse or improper installation or operation.
  - (c) **GOODS NOT MANUFACTURED BY HUTCHINSON/MAYRATH CARRY ONLY THE MANUFACTURER'S WARRANTY.**
  - (d) **THIS UNDERTAKING IS IN LIEU OF ALL OTHER WARRANTIES, EXPRESSED OR IMPLIED, INCLUDING MERCHANTABILITY AND FITNESS FOR A PARTICULAR PURPOSE.**
- FAILURE TO FOLLOW THE INSTRUCTIONS CONTAINED IN THE OWNER'S & OPERATOR'S MANUALS AND THE ITEMS LISTED BELOW WILL RESULT IN THE VOIDING OF THIS LIMITED WARRANTY.**
- (1) Improper assembly, including failure to properly install all safety equipment.
  - (2) Improper installation.
  - (3) Unauthorized alternations of goods.
  - (4) Goods operated when obviously in need of repair.
  - (5) Use of unauthorized repair parts.
  - (6) Irresponsible operation.
  - (7) Used to handle materials other than free flowing, nonabrasive and dry materials, as intended.
  - (8) Damaged through abusive use or accident.
- Limitation of Liability:** BUYER AGREES THAT IN NO EVENT SHALL HUTCHINSON/MAYRATH HAVE LIABILITY FOR DIRECT DAMAGES THE EXCESS OF THE CONTRACT PRICE OF THE GOODS IN RESPECT OF WHICH CLAIM IS MADE. BUYER FURTHER AGREES THAT IN NO EVENT SHALL HUTCHINSON/MAYRATH ON ANY CLAIM OF ANY KIND HAVE LIABILITY FOR LOSS OF USE, LOSS OF PROFITS, OR FOR ANY INDIRECT, INCIDENTAL OR CONSEQUENTIAL DAMAGES.

## GENERAL SAFETY STATEMENT

Occupational safety is of prime concern to us. This manual was written with the safety of the operator and others who come in contact with the equipment as our prime concern. The manual presents some of the day to day work problems encountered by the operator and other personnel. We wrote this manual to help you understand safe operating procedures for this equipment. We want you as our partner in safety.

It is your responsibility as an owner, operator or supervisor, to know what specific requirements, precautions and work hazards exist and to make these known to all other personnel working with the equipment or in the area, so that they too may take any necessary safety precautions that may be required. Avoid any alterations of the equipment. Such alterations may create a dangerous situation where serious injury or death may occur.

## SAFETY ALERT SYMBOL

The symbol shown below is used to call your attention to instructions concerning your personal safety. Watch this symbol - it points out important safety precautions. It means "ATTENTION! Become alert! Your personal safety is involved! Read the message that follows and be alert to the possibility of personal injury or death.



**BE ALERT! YOUR SAFETY IS INVOLVED.**



### WARNING

Anyone who will operate or work around a portable auger shall first read this manual! This manual must be delivered with the equipment to its owner. Failure to read this manual and its safety instructions is a misuse of the equipment.

# TABLE OF CONTENTS

General Safety Statements .....	1
Safety Symbol .....	1
Operator Qualification .....	3
Sign Off Sheet .....	3
Machine Inspection .....	3
TRANSPORTING AUGER .....	4-5
Hitching to Towing Vehicle .....	4
Hitch Safety Chain Installation .....	4
Moving Auger .....	4-5
PLACEMENT OF AUGER .....	5-6
Step 1 - Locate the Auger .....	5
Step 2 - Raising the Auger .....	5
Step 3 - Working Position .....	6
WINCH INSTRUCTIONS .....	6
DESIGNATED WORK AREA .....	7
OPERATING PROCEDURES .....	8-13
Start Up & Break In .....	8
PTO Drive Information .....	8-9
Electric Motor Drive .....	10
Underslung Gas Engine Drive .....	11
Lockout .....	12
Shut Down .....	12
Relocation of Auger .....	12-13
TROUBLE SHOOTING .....	13
LUBRICATION AND MAINTENANCE .....	14-15
Gearbox .....	14
PTO Driveline .....	14
Enclosed Drive .....	14
Friction Type Winch .....	14
Belt Adjustment .....	14
Bearings .....	15
ASSEMBLY INSTRUCTIONS .....	16-33
PARTS LIST	

## SERIAL NUMBER

To ensure efficient and prompt service, please furnish us with the model and serial number of your auger in all correspondence or other contact. The serial plate is located on the winch mount on the lower section of auger housing.

## RIGHT AND LEFT DESIGNATION

When determining which is the left or right hand side of the unit, it is as if a person were standing at the intake end and looking toward the discharge end.

## OPERATOR QUALIFICATIONS

Operation of this portable auger shall be limited to competent and experienced persons. In addition, anyone who will operate or work around a portable auger must use good common sense. In order to be qualified, he must also know and meet all other requirements, such as:

1. Some regulations specify that no one under the age of 16 may operate power machinery. This includes portable augers. It is your responsibility to know what these regulations are in your own area or situation.
2. Current OSHA regulations state in part: "At the time of initial assignment and at least annually thereafter, the employer shall instruct every employee in the safe operation and servicing of all equipment with which the employee is, or will be involved."\*
3. Unqualified persons are to stay out of the work area as shown in the work area diagrams. See Page 7.
4. A person who has not read and understood all operating and safety instruction is not qualified to operate the machine.

\*Federal Occupational Safety & Health Standards for Agriculture Subpart D, Section 1928.57 (1)(6).

## SIGN OFF SHEET

As a requirement of OSHA it is necessary for the employer to train the employee in the safe operation and safety procedures with this auger. We include this sign off sheet for your convenience and personal record keeping.

DATE	EMPLOYER SIGNATURE	EMPLOYEE SIGNATURE

## MACHINE INSPECTION

After delivery of your new auger and/or completion of assembly and before each use, inspection of the machine is mandatory. This inspection should include, but not be limited to:

1. Check to see that all guards listed in the assembly instructions are in place and secured and functional. PTO driveline outer shields must rotate easily.
2. Check all safety signs and replace any that are worn, missing or illegible. The safety signs are listed on pages P-1 and P-2. Safety signs may be obtained from your Dealer or ordered from the factory.
3. Check winch and cable for security and operation. There should be at least three complete wraps of cable around the winch drum when auger is in full down position. Cable anchor on winch drum must be tight.
4. Are all fasteners tight?
5. Are all belts and chain properly adjusted? (See Maintenance Section.)
6. Check oil levels in gearbox and enclosed drive unit. (See Maintenance Section.)

# TRANSPORTING

**TRANSPORT:** Moving the auger with a towing vehicle to or from the work area.

## 1. HITCHING TO TOWING VEHICLE INSTRUCTIONS.

Make certain the hitch pin is securely attached and an alternate hitch safety chain is secured to the auger and towing vehicle. Check to see that the hitch is securely attached.

Never raise the intake end higher than is necessary to attach to a towing vehicle. Weight transfers rapidly to the head end when the intake is raised.

**NOTE: Empty auger before moving to prevent upending.**

Never stand between the tractor and auger when hitching unless all controls are in neutral and the brakes locked.

### PORTABLE AUGER IN TRANSPORT POSITION

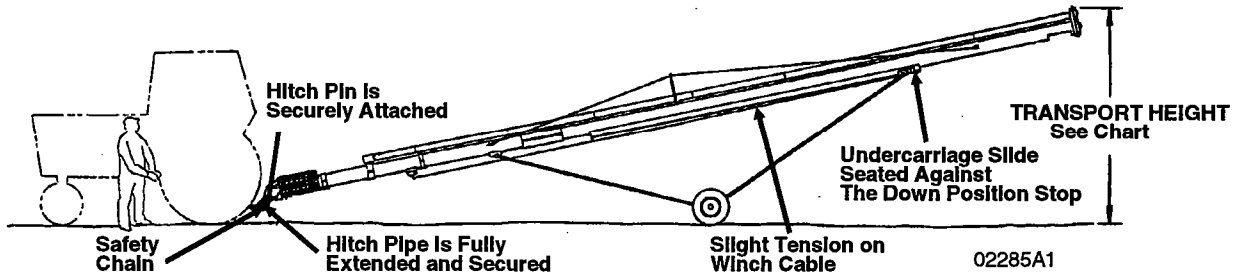

AUGER LENGTH	6" x 31'	6" x 41'	6" x 51'	6" x 61'
*TRANSPORT HEIGHT	9'-4"	10'-10"	13'-1"	13'-6"

**\*IMPORTANT:** Transport heights are figured with auger attached to towing vehicle with a drawbar height of 1'-6". When the auger intake is resting on the ground, add 1'-6" to transport height of the auger to achieve the overall auger height.

## ALTERNATE HITCH SAFETY CHAIN INSTALLATION

An auxiliary attachment system (safety chain) is required to retain the connection between towing and towed machines in the event of separation of the primary attachment system.

The safety chain should be routed through the intake guard safety screen and around the bearing support at the lower end of the intake flight. Then route the chain through the chain support on the hitch pipe.

A clevis or intermediate chain support should be fastened to the tractor drawbar no farther than 6" from the hitch pin.

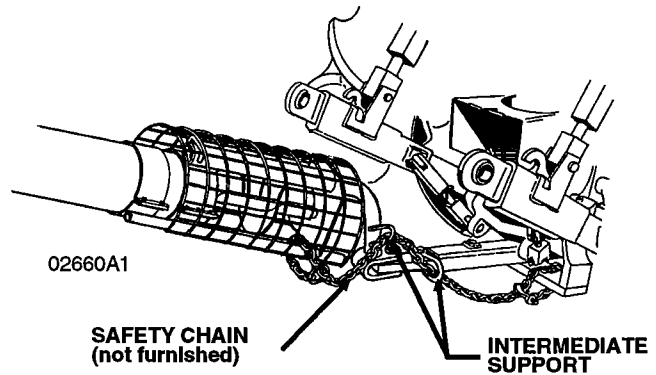

## 2. MOVING AUGER

Moving your portable auger requires careful planning. A route plan should be considered beforehand to avoid dangerous obstacles and loss of time.

Always transport your auger in the full down position. The lift arm of the undercarriage should be seated against the down position stop with slight tension on the winch cable and at least 3 complete wraps of cable around the winch drum.

Never allow persons to stand underneath or ride on the auger when moving it. Make certain everyone is clear of the work area before moving.

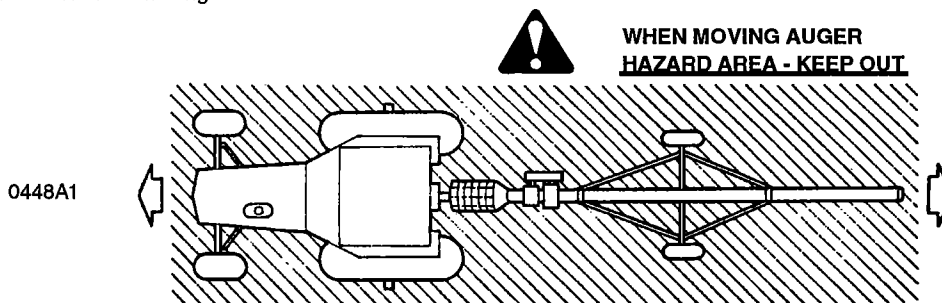

## TRANSPORTING - (cont'd.)

**DO NOT** transport the auger at speeds in excess of 20 MPH. Comply with your state and local regulations governing marking, towing and maximum width. Observe safe driving and operating practices.

**Be alert to overhead obstructions and electrical wires.**

Failure to do so may result in electrocution. Lower auger well below level of power lines before moving. Maintain at least ten (10) feet of clearance. Page 4 contains a chart showing the height of each portable auger in the lowered transport position. Check the chart to determine the height of your auger.

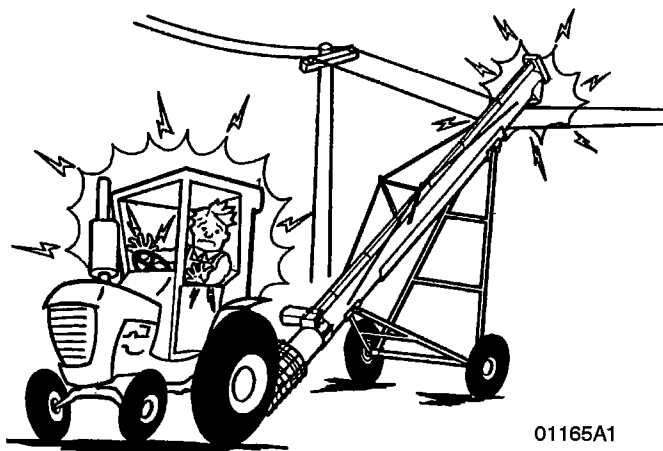

01165A1

## PLACEMENT OF AUGER - FILLING GRAIN BIN

Placement - Move the auger into its working position with a towing vehicle.



01164A1-3

### STEP 1

Locate the auger as close as possible to the bin or other structure. Move auger slowly towards working position with a towing vehicle--not by hand. When moving the auger toward the working position leave adequate room for a convenient path for loaded vehicles to reach the auger intake area.

**Make certain everyone is clear of the work area when moving the auger. To prevent tip-over when backing, avoid rolling over any obstructions, also avoid steep slopes. If the auger is to sit on a slope, approach the bin up hill. Avoid moving the auger at right angles to a slope.**



**Make sure entire area above auger and in line of travel is clear of overhead obstructions and electrical wires. Failure to do so may result in electrocution. Maintain at least ten (10) feet of clearance between the auger and power lines. Electrocution can occur without direct contact.**

### STEP 2

Raise the auger only high enough to allow minimum clearance above the bin peak.

#### TO RAISE THE AUGER WITH HAND WINCH:

Turn the handle clockwise (pull cable onto winch drum). There should be a clicking sound.

**NOTE: The winch is equipped with a brake that is actuated by turning the handle. The brake is designed to hold the load whenever the handle is released.**

**NOTE: Observe the cable as it is winding onto the winch drum. The cable should roll up on the drum evenly; avoid cable build-up on one side of the drum.**



**Keep hands away from winch drum during operation.**

A0003252

## PLACEMENT OF AUGER - FILLING GRAIN BIN - (cont'd.)

### STEP 3

Back auger slowly into working position with towing vehicle. **NEVER MOVE THE AUGER BY HAND, USE A VEHICLE.**

**DO NOT ATTEMPT TO INCREASE AUGER HEIGHT BY POSITIONING WHEELS ON LUMBER, BLOCKS OR BY OTHER MEANS.**

Once in place, the wheels should be chocked on both sides so the auger will not roll when disconnected from the towing vehicle.

When releasing from the towing vehicle, test the intake end for downward weight. **LOWER IT SLOWLY TO THE GROUND.** **NOTE:** Weight transfers rapidly to the head end if the intake is raised above the tow bar, particularly when the auger is in a raised position.

Remove bolt from hitch and fully retract hitch pipe. If a hopper is to be used, install at this time. Lower the auger until the auger discharge is directly over bin opening.

### **TO LOWER AUGER WITH HAND WINCH:**

Turn the handle counter-clockwise; there will be no clicking sound. To stop while lowering the auger, turn the handle clockwise until you hear two clicks to lock brake. (About 6" movements of the handle.)

The auger should be anchored at the intake end and/or supported at the discharge end. This will prevent auger from tipping when weight transfers to top end as auger empties. It is a good practice to tie the discharge end of the auger to the bin or grain storage structure to prevent possible wind damage. Remember to untie the auger before attempting to move.

**NOTE:** When discharging into a grain spreader, always maintain at least 12 inches of space between the auger discharge and the spreader.

## WINCH INSTRUCTIONS

### **HAND WINCH OPERATION (FRICTION TYPE)**

Check the handle assembly on your auger to determine that it has been assembled correctly. See assembly section. There should be a locknut attached to the end of the winch shaft to prevent inadvertent removal of the winch handle.



**Never fully extend the cable and always keep three complete turns of cable around winch drum.**

**Never operate winch with wet or oily hands and ALWAYS use a firm grip on the handle.**

### **SAFETY REMINDERS**

- (1) Operator must pay attention during raising and lowering auger.
  - (A) Watch cable to see if it is coiling properly onto winch drum evenly.
  - (B) Keep hands away from winch drum during operation.
  - (C) Don't use hands to guide cable onto winch drum during winch operation.
  - (D) Don't allow auger to become hung up.
  - (E) Don't continue to raise auger after slide reaches stop.

For additional winch information, see the separate winch owner's manual provided with this auger.

# DESIGNATED WORK AREA

Before starting the auger, a designated work area should be established and properly marked. The following diagram shows the recommended designated work areas. These areas shall be marked off with colored nylon or plastic rope hung as portable barriers to define the work boundaries.

## RULES FOR SAFE WORK AREA

Under no circumstances should persons not involved in the operation be allowed to trespass into the work area.



It shall be the duty of all operators to see that children and/or other persons stay out of the work areas! Trespass into the work area by anyone not involved in the actual operation, or trespass into a hazard area by anyone, shall result in an immediate shut-down by the operator.

It shall be the responsibility of all operators to see that the work area has secure footing, is clean and free of all debris and tools which might cause accidental tripping and/or falling.

GAS AND ELECTRIC DRIVE UNITS

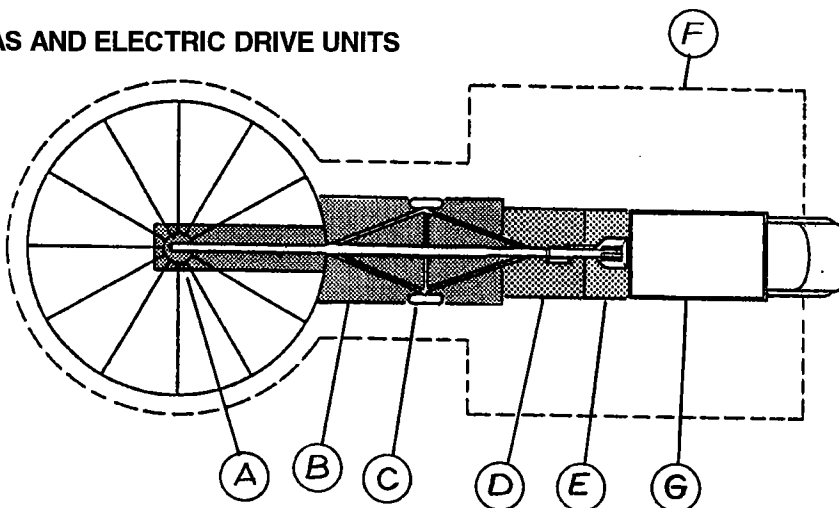

**KEEP AWAY FROM OVERHEAD WIRES!**

A - Support the Discharge End and/or Anchor the Intake

B - Under Auger and Undercarriage Area - Hazard -- KEEP OUT!

C - Wheels should be chocked in front and back.

D - Auger Drive Area -- KEEP OUT!

E - Auger Intake Area -- KEEP OUT!

F - Work Area -- Authorized Personnel ONLY

G - Gravity Wagon or Truck

PTO DRIVE UNITS

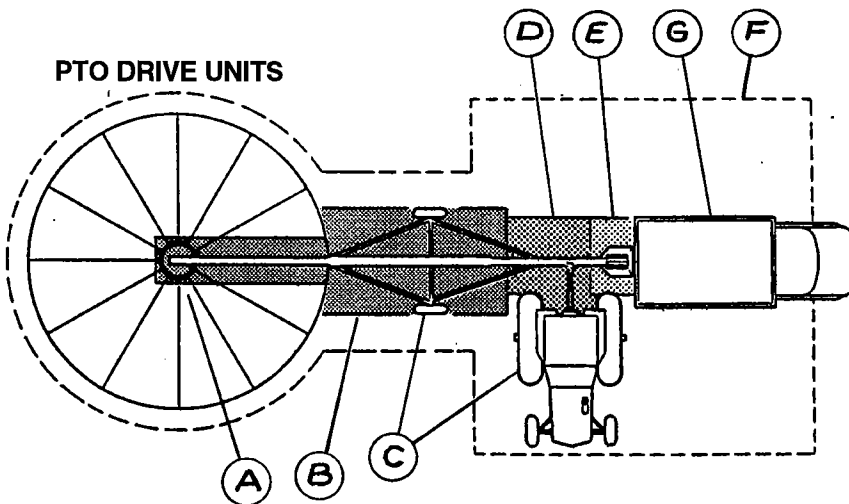

Walking Surface -- Is it slippery? Are there things to trip you?

# OPERATING PROCEDURES

## START-UP AND BREAK-IN INFORMATION

Our augers are well made and we are proud of our line of equipment. We would like you, as our customer, to do your part in using caution and good judgement in using our equipment, as well as any other machinery.

It is essential to inspect your drive before adding power and know how to shut down in an emergency. During the operation of your auger, one person shall be in a position to monitor the operation.

Any screw conveyor when it is new or after it sets idle for a season should go through a "break-in" period. The auger should be run at partial capacity until several hundred bushels of grain have been augered to polish the flighting assembly and tube. Once this is accomplished, the auger can be run full.

Never operate the auger empty for any length of time as excessive wear will result. If at all possible do not stop or start the auger under load, especially before the flight and tube become well polished, as this may cause the auger to "freeze-up".



**During the initial start-up and break-in period, the operator shall be aware of any unusual vibrations or noises.**  
**Keep all safety shields and devices in place.**  
**Keep hands, feet and clothing away from moving parts.**  
**The operator shall have a full view of the auger work area and check that all personnel are clear of hazard areas before adding power.**

## FLIGHT SPEED

Proper auger flight speed is important for efficient operation of the auger.

1. Recommended flight speed is from 640 to 750 RPM for augers equipped with standard flight.  
**IMPORTANT:** On augers equipped with intermediate flight bearings, DO NOT EXCEED 500 RPM.
2. If the flight speed is faster than what is recommended, excessive wear will result.
3. If the flight speed is too slow and the auger flighting is permitted to "load-up", high torque will be required to turn the auger flighting, possibly resulting in damage to the auger. Reduced capacity should be obtained by limiting the flow into the auger rather than by reducing the speed of the auger.

## OPERATING CAPACITY

The results or capacities of screw conveyors or augers can differ greatly under varying conditions. Different materials, moisture content, amounts of foreign matter, methods of feeding and speed all play a role in the performance of the auger. The maximum possible capacity will be less with high moisture grain than with dry grain.

MATERIAL	CAPACITY B.P.H.
Dry Grain	1600-2000

An inclined auger with one foot of grain over the inlet flight will probably get better capacity than if it had only a one inch covering. On the other hand, an auger in the bottom of a cone shaped pit or under a bulk tank with perhaps four or more feet of grain on top of it may be overfed. This overfeeding is caused from the weight of the grain over the intake forcing more into the auger than it can efficiently move. The result is an increased horsepower requirement, extra strain on the driveline, and possibly a complete stall out. Under "extra" pressure conditions, a control gate should be used.

## DIRECT PTO DRIVE

**Only use a tractor with 540 RPM Power Take-Off.**

The standard Direct PTO may be driven from either side (as explained in the PTO Drive Assembly Section).

**NOTICE: The PTO driveline furnished with the auger is equipped with a "Spring-Lock" coupler at the tractor end. This coupler is spring loaded and will fit the standard 1 3/8" x 6 spline PTO output shaft from a tractor.**

See that the PTO driveline is securely attached and the retaining balls of the "Spring-Lock" coupler lock into the ring groove of the tractor output PTO shaft. Check this by trying to pull the driveline off of the tractor output PTO shaft.

## CHECK THE FOLLOWING BEFORE ADDING POWER:

1. Be certain that the PTO driveline is securely attached to the auger and the tractor.
2. Never use an PTO driveline without a rotating shield in good working order that you can turn freely on the shaft.

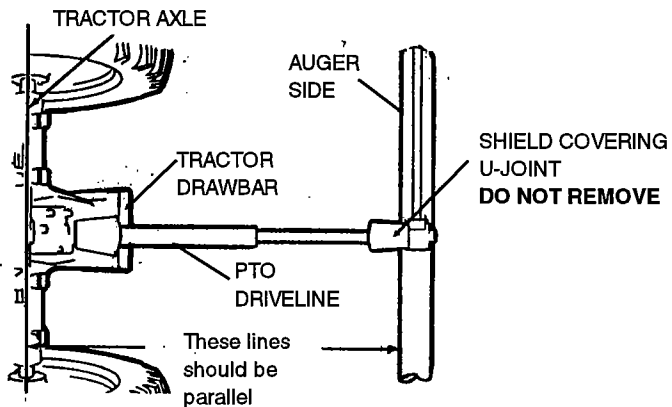

# OPERATING PROCEDURES

## DIRECT PTO DRIVE - (cont'd.)

3. Align PTO driveline with tractor. The input drive line furnished with the auger is a pin stop type—that is, the two telescoping sections will not separate. It is a good practice to operate the PTO in as short a configuration as possible. Keep the input driveline in as straight a line as possible during operation. When connecting tractor and auger, always make sure the tractor axle and side of auger are parallel. **KEEP THE U-JOINT ANGLES EQUAL.**

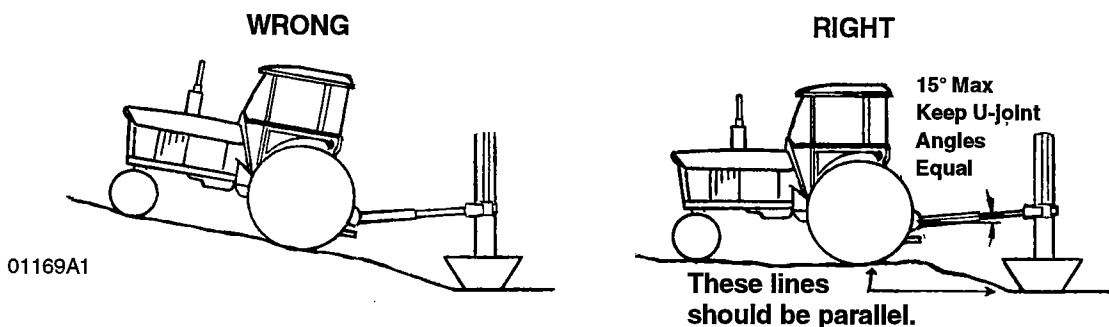

4. If the tractor and auger are on unlevel ground or at different levels, place them so the center line of the tractor and the gearbox shaft are parallel.



**Before engaging the PTO, be sure the PTO driveline shields turn freely on shaft.**

### TO START AUGER:

1. Before starting the tractor, be certain power to PTO is off.
2. Start tractor.
3. Engage PTO at a slow RPM to minimize shock loads, then work up RPM to recommended speed.

### TO STOP AUGER:

1. Let auger empty of grain before stopping.
2. Disengage PTO and lockout.

## ELECTRIC MOTOR DRIVE:

Use a 1750 motor with required H.P. suggested in chart on page 10. Electric motors and controls shall be installed by a qualified electrician and must meet the standards set by the National Electrical Code and all local and state codes. **Use a 3.5" motor pulley (not furnished) for 658 RPM.**

A magnetic starter should be used to protect your motor when starting and stopping. It should stop the motor in case of power interruption, conductor fault, low voltage, circuit interruption or motor overload. Then the motor must be restarted manually. Some motors have built-in thermal over-load protection. If this type motor is used, use only those with manual reset.



**Reset and motor starting controls must be located so that the operator has full view of the entire operation. A main power disconnect switch capable of being locked only in the OFF position shall be provided. This shall be locked whenever work is being done on the auger.**



**Make certain everyone is clear before operating the equipment.**



**Keep hands, hair, feet and clothing away from moving parts.**



**Shut off and lock out power to adjust, service or clean.**

# OPERATING PROCEDURES

## ELECTRIC MOTOR DRIVE (cont'd.)

Use a motor size at the lower end of the range for dry, shelled corn or wheat. For higher moisture grain (up to 25%) use the upper end of the horsepower range. For grain exceeding 25% moisture, the next size larger motor above the range listed may be used as a maximum.



**Disconnect power before resetting motor overloads. Make certain electric motor is grounded.**

Horsepower Requirements	
LENGTH	HORSEPOWER
31'	5
41'	5
51'	7 1/2
61'	7 1/2 - 10

### BEFORE ADDING POWER:

1. Check that belt guard is in place, secured and functional.

### TO START AUGER

1. Start electric motor before conveying grain.

### TO STOP AUGER

1. Let auger empty of grain before stopping.
2. Shut off electric motor and lockout.

## UNDERSLUNG GAS ENGINE DRIVE

(For 31' and 41' Models Only)

**IMPORTANT:** Use the proper size and speed motor to ensure satisfactory auger operation. Too small of a motor will not supply the horsepower required to achieve capacity, possibly causing damage to the motor. Too large of a motor may cause high stress on the auger components resulting in shorter life for those components.

The horsepower recommendations are for augering reasonably dry grain at varying angles. Maximum possible capacity will be less with high moisture grain than with dry grain.

AUGER LENGTH	MOTOR HORSEPOWER REQUIRED	GEARBOX RATIO	GEARBOX SHEAVE	*MOTOR/ENGINE SHEAVE	RECOMMENDED AUGER FLIGHT SPEED
31'	8	1 1/2 to 1	12"	3.5" O.D.	740 RPM
41'	10		12"	3.5" O.D.	740 RPM

\*Engine/motor sheave is not furnished.

### CHECK THE FOLLOWING BEFORE ADDING POWER:

1. The drive belt must be adjusted for proper tension. Adjustment is made by using the handle adjustment strap.



**Never attempt to adjust or service the engine or any other drive components while it is in operation.**

2. The underslung mount is designed to pivot on the gearbox ears to allow the motor mount to set level.
3. Check that all belt guards are in place, secured and functional.



**Shut down and allow engine to cool before filling with fuel. Consult the engine manufacturer for engine information.**

# OPERATING PROCEDURES

## UNDERSLUNG GAS ENGINE DRIVE - (cont'd.)

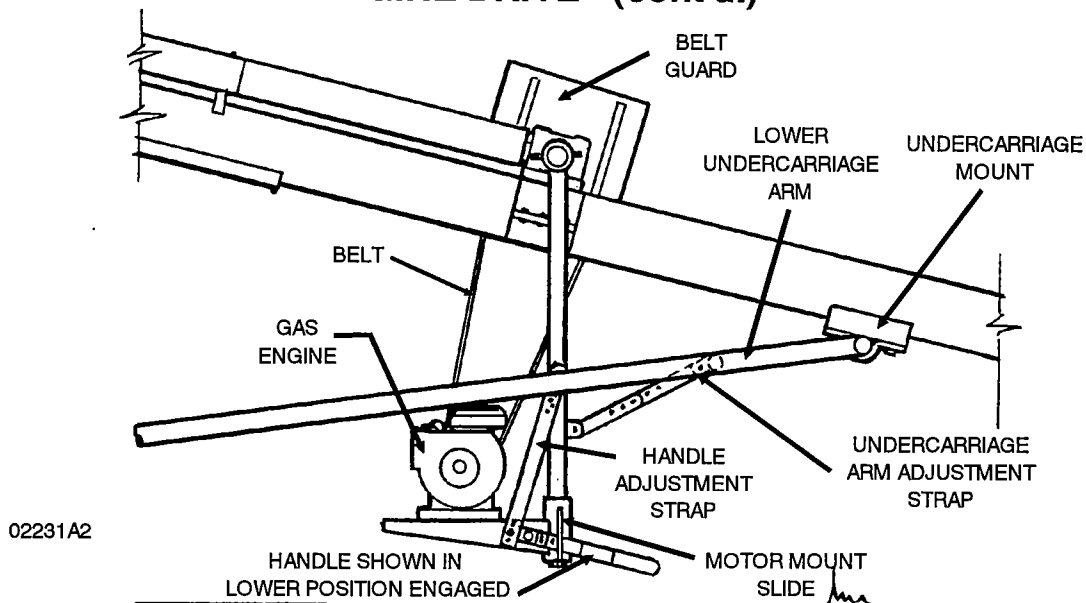

### TO START AUGER:

1. Before starting engine, be certain that the handle is in the **upper** position (disengaged). The belts should be loose.
2. Start the engine and bring up to working R.P.M.
3. Move the handle to the side slowly, then slide down and lock in the **lower** engaged position.

**NOTE:** If the drive belts slip during grain conveying operations, empty and stop the auger, then lockout the drive and adjust the belt tension by moving the handle adjustment straps to another position.

### TO STOP AUGER:

1. Let auger empty of grain before stopping.
2. Disengage handle.
3. Shut off engine and lockout by removing ignition key, spark plug wire or spark plug.

## FULL LOAD OPERATING PROCEDURES

During the regular operation of this equipment, one person shall be in a position to monitor the operation.

It is good practice to visually inspect the auger periodically during the actual operation. You should be alert for unusual vibrations, noises, and the loosening of any fasteners.



Observe work area restrictions.



Keep all safety shields and devices in place.



Make certain everyone is clear before operating the equipment.



Keep hands, hair, feet and clothing away from moving parts.



Shut off and lock out power to adjust, service or clean.

# OPERATING PROCEDURES

## LOCKOUT

If the operator must leave the work area, or whenever servicing or adjusting, the auger must be stopped and the power source turned off. Precaution should be made to prevent anyone from operating the auger when the operator is absent from the work area.

**DIRECT PTO DRIVE:** Remove ignition key or coil wire from power source. (If this is impossible, remove the PTO driveline shaft from the work area.)

**TOP MOUNTED ELECTRIC DRIVE:** A main power disconnect switch capable of being locked only in the off position shall be used.

**GAS ENGINE DRIVE:**

1. For engines with rope or crank start- remove spark plug wire or spark plug.
2. For engines with electric start - remove ignition key, spark plug wire or spark plug.

## SHUTDOWN

**A. NORMAL SHUTDOWN**

When shutting down the auger make certain that the hopper and auger are empty before stopping the unit. Before the operator leaves the work area, the power source shall be locked out. (See Lockout.)

**B. INTERMITTENT OPERATION SHUTDOWN**

When an auger is stopped and restarted under full load, it may result in damage to the auger. Therefore, if intermittent operation is to be carried out, it is advisable to use a flow restricting device to reduce the load level. Slide gates and intake control gates can be used for this purpose. When kept from absolute filling, auger start-up is easier and operation is more efficient.

If the auger is to be used in a force feed system, flow should be further restricted to reduce the load adequately for safe intermittent operation.

**C. EMERGENCY SHUTDOWN**

Should the auger be immediately shut down under load, disconnect and lockout the power source. Clear as much grain from hopper and auger as you can. Reconnect power source and clear auger. Never attempt to start when full.

**NOTE: Starting the unit under load may result in damage to the auger. Such damage is considered abuse of the equipment.**

## RELOCATION OF AUGER

When grain conveying operation is completed, the auger should be moved away from the bin and lowered. The auger then can be moved to a different location for more conveying operations or cleaned up and stored.

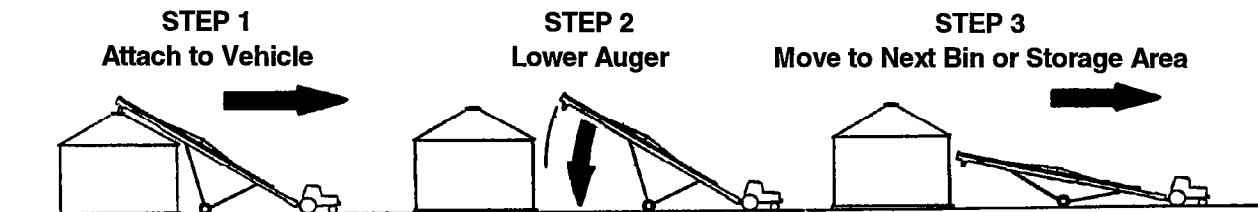

01164A1

**Step 1**

- A. Empty all grain from the auger. Clean up the area.
- B. Disconnect the power source.
- C. Untie any anchors and/or remove all supports.  
**Top Mounted Electric Drive** - Unplug electric motor, wind up electric cables.  
**Direct PTO Drive** - Disconnect PTO driveline from tractor and place in the support bracket provided for transport.

**NOTE: The pin must be in place to keep the PTO shaft from coming out of the support bracket during transport.**

- D. Raise the auger so the discharge spout is clear of bin opening. See Auger Raising Instructions on page 6.
- E. Remove hopper (if any) from auger intake and secure hitch in place with bolt and nut.
- F. Lift the auger intake and hitch it to the towing vehicle. (See Hitching Instructions on page 4.)
- G. Remove wheel chocks.
- H. Move auger slowly away from the bin with towing vehicle--**NOT BY HAND.**

# OPERATING PROCEDURES

## RELOCATION OF AUGER - (cont'd.)

### Step 2

A. Lower auger immediately after clear of bin or storage structure. See Lowering Instructions on page 6.

**IMPORTANT:** Lower the auger, even if relocating to a bin in the immediate area.

### Step 3

- A. Move the auger to the next bin or storage area.
- B. If storing, we recommend that the auger be in the full down position with the intake end anchored.
- C. Inspect the auger as outlined in the "Machine Inspection Section" on page 3.

## TROUBLE SHOOTING

### LOW CAPACITY

The auger may not be getting enough grain. Check to see the intake has not "bridged over" restricting the flow.

The exposed flighting at the auger intake should be covered with grain to achieve maximum capacity.

Check auger speed. (See page 8.) A slow speed (below recommended speed) will result in low capacity.

### AUGER PLUGS

The auger may be getting too much grain causing "jamming" inside the housing. An optional control gate may be necessary at the intake end.

On motor drive augers, the motor may be too small or wired improperly. If the motor is a newer light weight aluminum type, the next larger size should be considered. (See HP requirements, page 10.)

If wet grain or other hard to move material is being augered, a larger size motor may be required. (Refer to HP requirements, page 10.)

Is the auger free of any foreign material, such as sacks, tarp corners, etc.? A plug of the discharge end will cause an auger plug also.

On electric powered units, check to see if all belts are lined up and tensioned properly.

### EXCESSIVE AUGER NOISE

Damage may have occurred to the auger flighting, thus causing noise. Damage usually occurs because of foreign material having been run through the auger. It may be necessary to remove the flighting for inspection.

**IMPORTANT:** This auger should be frequently checked and serviced to operate freely. Keep all guards and shields in place. Replace any that are damaged or lost.

**Any parts needing replacement should be replaced with parts of the same type and size. Do not modify or alter any of the auger components.**

**Run the auger partially full for several hundred bushels to polish the flight if it has not been used for an extended period of time. An auger with flighting that has not been polished in this manner requires greater horsepower, and damage to the drive and/or flighting can result if overloaded.**

# LUBRICATION AND MAINTENANCE

For economical and efficient operation of your auger maintain regular and correct lubrication. Neglect leads to reduced efficiency, excessive wear and needless down time.



**Keep all safety shields and devices in place.  
Never clean adjust or lubricate a machine that is in operation.**

The following will detail the parts needing lubrication and the various conditions which determine the time span.

## GEARBOX

The gearbox may be shipped without oil. At field assembly of auger, 90 E.P. (non-foaming) oil is to be added to the gearbox until half full, Check and maintain the level regularly.

## PTO DRIVELINE

Augers equipped with a PTO driveline, should have the u-joints lubricated at approximately ten (10) hour intervals with SAE multipurpose type grease.



**Before engaging P.T.O., be sure the driveline shields turn freely on the shaft.**

The PTO driveline is equipped with a shear bolt at the tractor connection. The shear bolt protects the auger from damage if the auger becomes plugged or subjected to high loads. Extra shearbolts are provided with the auger. It is important to use a replacement bolt of the proper size and strength to insure that the shear device will protect the auger and operator.

For 6" augers, use replacement shear bolts, 5/16"-18 x 1" long Grade 5 hex head capscrew.

## ENCLOSED DRIVE LUBRICATION

The enclosed drive is located at the discharge end of the auger housing and may be shipped without oil. Oil is to be added to the unit during field assembly of the auger. Oil will dissipate under normal operating conditions, therefore the oil level should be checked regularly. Add 90EP (non-foaming) oil until the level of the oil reaches the check port.

DO NOT ADD MORE OIL THAN RECOMMENDED.

OVERFILLING MAY DAMAGE THE SEALS OR FORCE OIL OUT THROUGH THE VENTED PLUG.

For lubrication in normal operating temperatures (between 40° F to 120° F), we recommend the use of non-foaming, multi-purpose gear oil, SAE 90 weight. For temperatures below 40° F, use SAE 80 weight oil. Use a grade commercially available for automotive differentials. Extra pressure additives may be of value in severe applications.

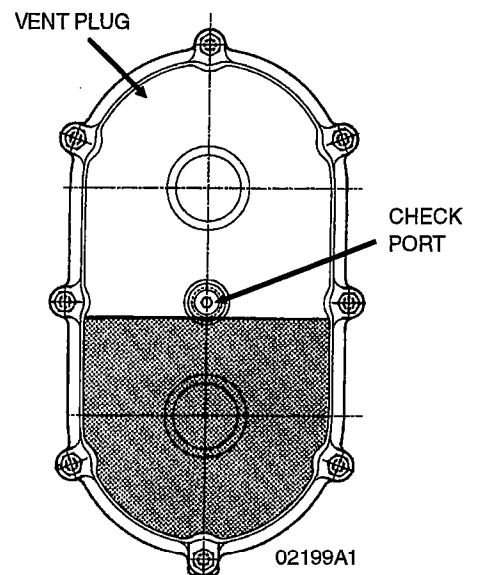

## FRICITION TYPE WINCH

The following checks should be made to the winch periodically.

The auger should be in the lowered position with the undercarriage lift arm slide seated against the down position stop when this inspection is being performed. Refer to operating and maintenance instructions furnished with your winch for proper inspection methods. Page P-8 of this manual shows winch parts.

1. All gears should have a film of grease on them at all times.
2. The following parts must be wet with oil at all times:
  - (A) Two bushings located at ends of drum shaft.
  - (B) The ratchet pawl pivot.

**IMPORTANT: Do not get oil or grease on brake disc faces (located between ratchet gear, brake hub and pinion shaft.)**

3. Check brake discs. If either is worn to less than 1/16", is cracked or broken, then replace both discs.

## BELT ADJUSTMENT

On drives that are powered by belts, the belt tension will need periodic adjustment. See the operating procedures section for belt adjustment location.

## LUBRICATION AND MAINTENANCE - (cont'd.)

### BEARINGS

#### Drive Shaft Bearing

All drive shafts are supported by self-aligning, sealed ball bearings, which have been packed at the factory and require no further lubrication. There is no adjustment to be made to the bearings but to check that the retainers are firmly fastened to the bearing stand. Also check that the setscrews in the lock collars are tight against the drive shaft, securing the lock collars to the drive shaft.

**IMPORTANT: The complete drive shaft must be shielded with drive shaft covers during operation.**

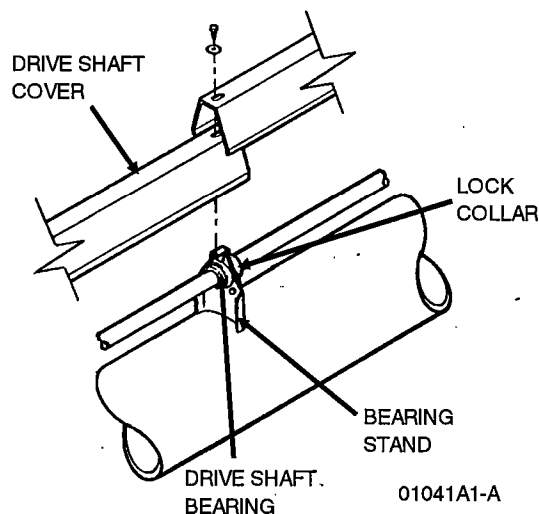

**KEEP ALL SAFETY SHIELDS AND DEVICES IN PLACE.**

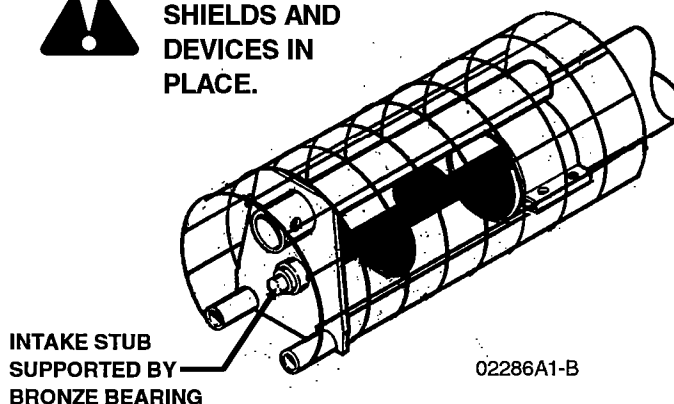

#### Intake Guard Bronze Bearing

Every auger has a bronze-with-graphite bearing at the intake end. This bearing requires no lubrication. If intake wire guard is damaged, replace the intake guard. See page P-5.

#### Undercarriage Axle Spindle Bearing

Tapered roller type bearings are standard for 6" augers and should be repacked with grease and adjusted annually or as needed, determined by usage.

#### TAPERED ROLLER TYPE BEARING ASSEMBLY

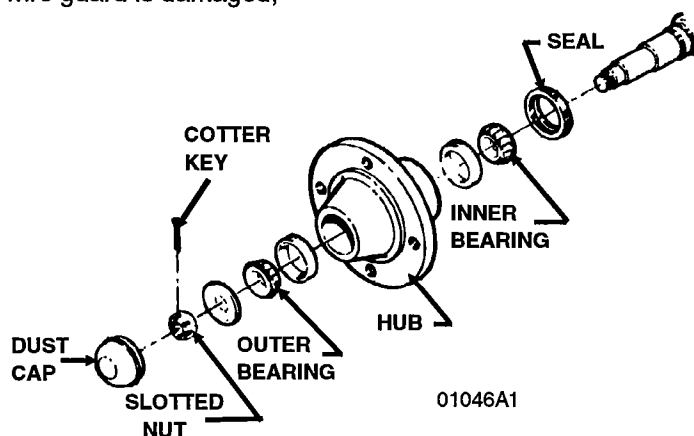

Care must be used in dismantling the wheel bearing assembly. First remove the dust cap by prying around its edges. Remove the cotter pin, slotted nut and flat washer. Carefully remove the hub and bearings from the spindle. Inspect all parts for wear or damage and replace with new ones if necessary.

When reassembling the hub, repack both bearing cones with grease and fill the hub cavity 1/3 full. Place inner bearing assemblies into the hub, and then press grease seal into hub and carefully reinstall the hub on the spindle. When placing hub on spindle be careful not to damage the lip of the grease seal. Install outer bearing assembly into the hub, and replace flat washer and slotted nut. Tighten the slotted nut to seal the bearings until the hub binds as you rotate hub. Back off the slotted nut to the next slot and pin with a new 5/32" x 1-1/4" long cotter pin. Replace dust cap.

# ASSEMBLY INSTRUCTIONS

Choose an area of open level ground accessible to a chain hoist or other lifting device where the auger may be laid out full length. Lay the tube assembly sections in position as shown below.

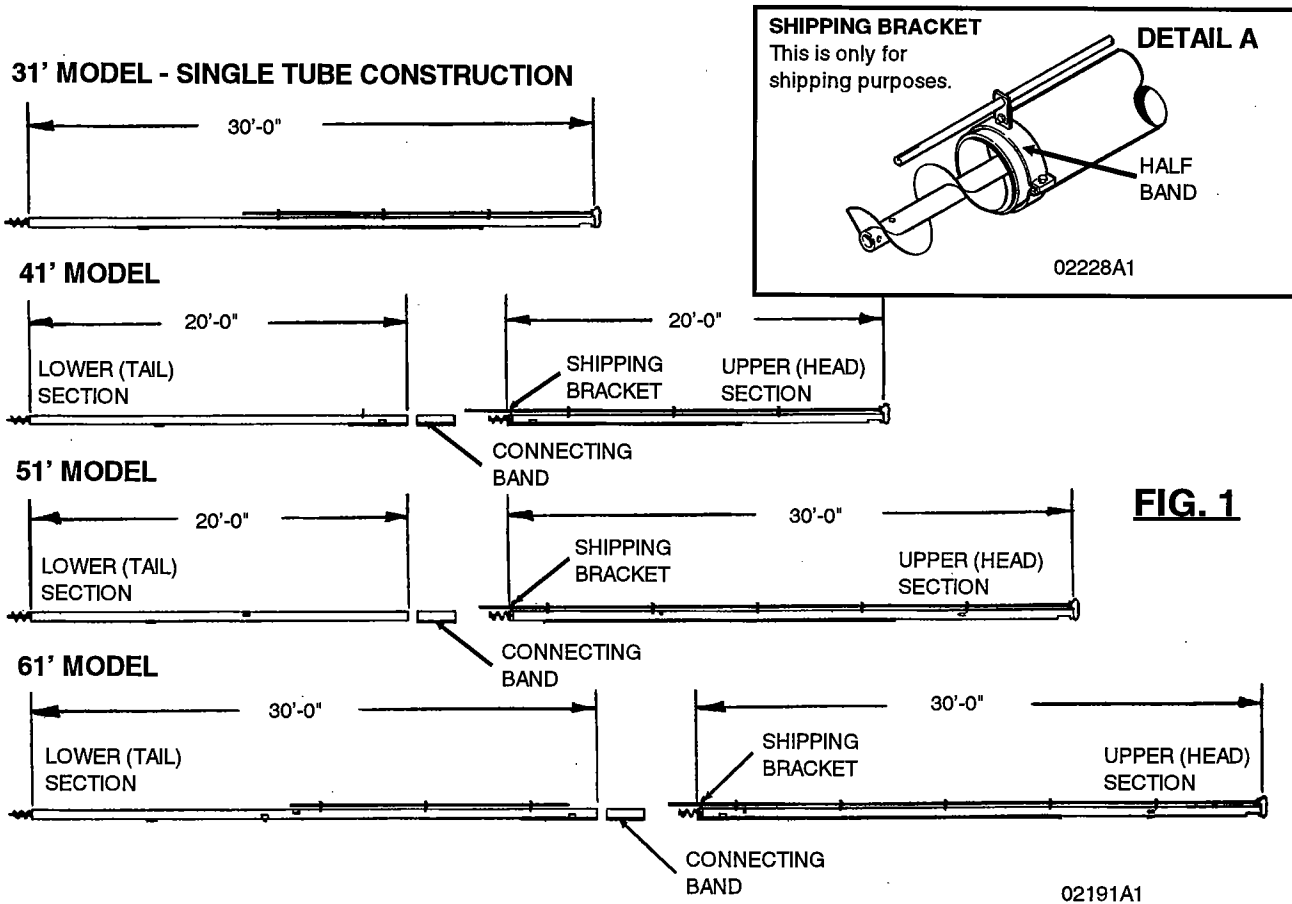

## SHIPPING BRACKET

Remove the shipping bracket and mounting half band from the drive shaft. See Figure 1 for location of shipping bracket on 41', 51' and 61' models of augers.

## FLIGHT CONNECTION (41', 51' AND 61' MODELS)

**IMPORTANT:** Slide the connecting band over the end of the lower auger tube before connecting flight together.

Bolt the sections of auger flighting together, using one 3/8" x 1 3/4" bolt and locknut. The lower section of flighting will lap the upper section flighting about one inch on the side toward the auger outlet. See Figure 2.

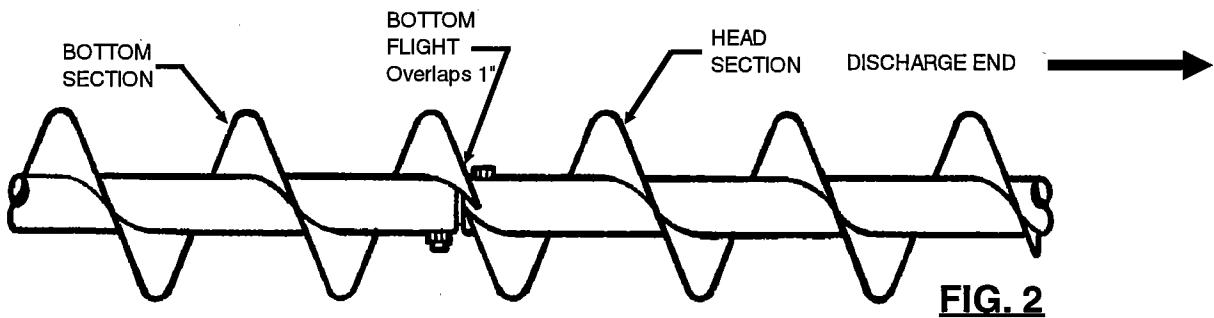

# ASSEMBLY INSTRUCTIONS

## TRACK ASSEMBLY (41' AND 61' MODELS)

The connecting band must be installed onto the auger tube housing before track sections are bolted together. Put the auger tube housings tight together and bolt the track brackets together using two 3/8" x 1" hex head capscrews and locknuts.

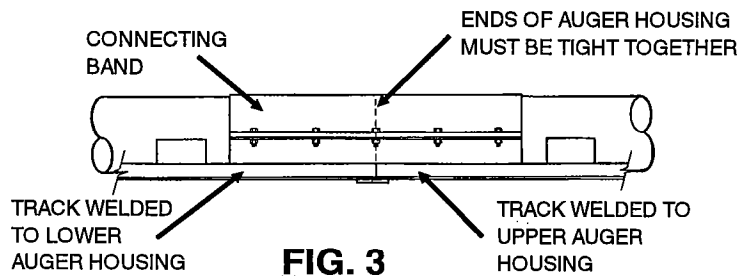

**FIG. 3**  
SIDE VIEW OF  
TRACK

02230A1

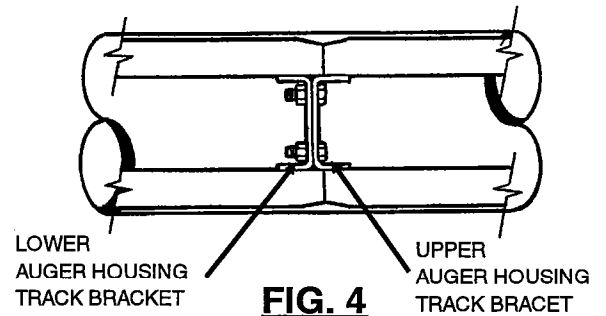

**FIG. 4**  
BOTTOM VIEW OF  
TRACK CONNECTION

02229A1

## CONNECTING BAND

Tighten connecting band to tube using five 3/8" x 1-1/4" hex head capscrews and nuts. Be sure auger housing tubes are tight together. About half of the band should be on each tube section.

## INTAKE GUARD

Install intake guard assembly at intake end of auger. Slide the assembly over the flighting and the housing. Insert intake stub shaft through the bearing and clamp the assembly to the auger housing. Top half band should be on the "up" side of the welded stop. See Figure 5.

Use a 1/2" x 3 1/2" bolt with flat washer, lockwasher and nut to hold hitch pipe in extended position for towing the auger.

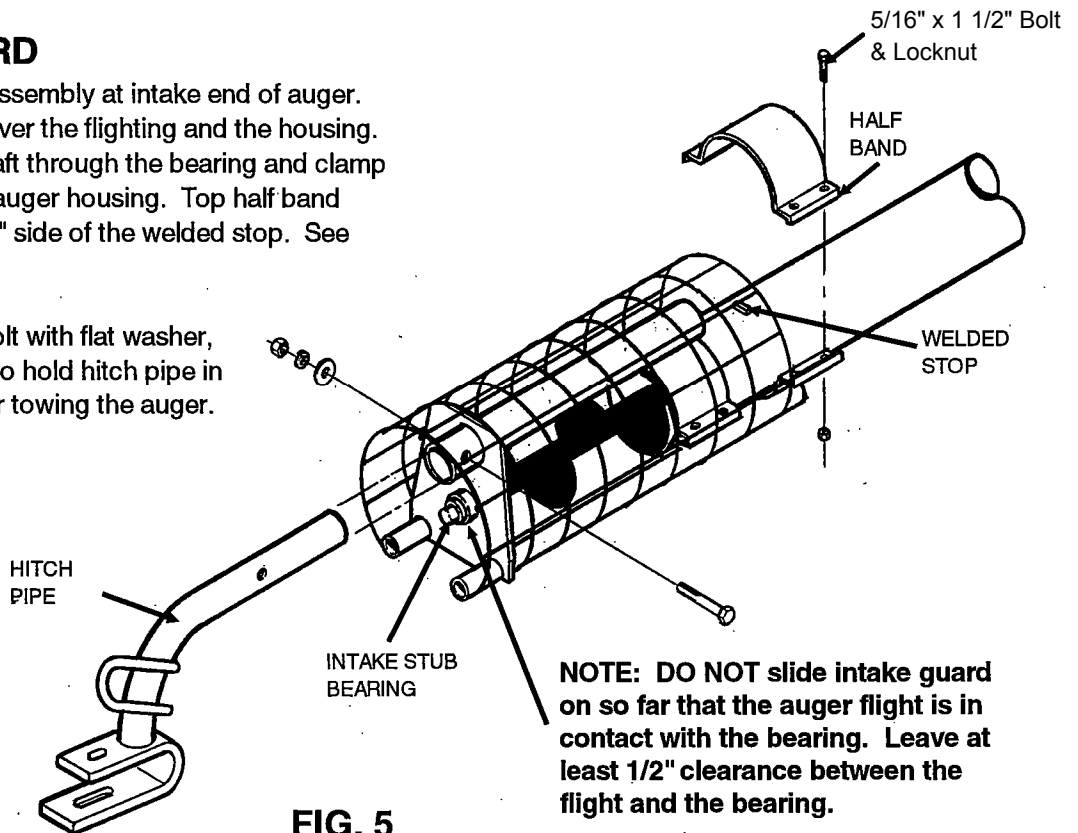

**FIG. 5**

02286A1-A

# DRIVE SHAFT EXTENSION

## WELDED-ON BEARING STANDS

1. Bolt a bearing to the welded-on bearing stand on the 41' Models. Attach each bearing using two retainers and one drive shaft cover mounting bracket and one locknut (See Fig. 6).

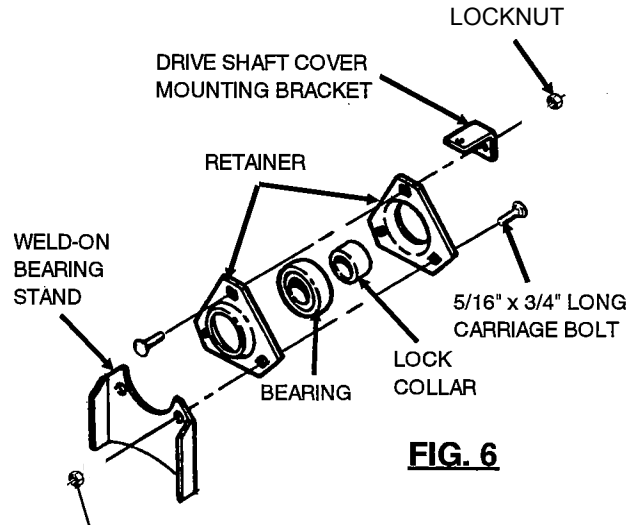

**FIG. 6**

## BAND-ON BEARING STANDS

1. Bolt a bearing to the band-on bearing stand. Use two retainers and one drive shaft cover mounting bracket. (See Fig. 7.)
2. Slide the bearing stand onto the extension drive shaft (See Fig. 8). For correct bearing stand placement, See Pages 21-22. Fasten band-on bearing stand to auger tube as shown. Tighten setscrews in the lock collar to lock the bearing to the drive shaft.

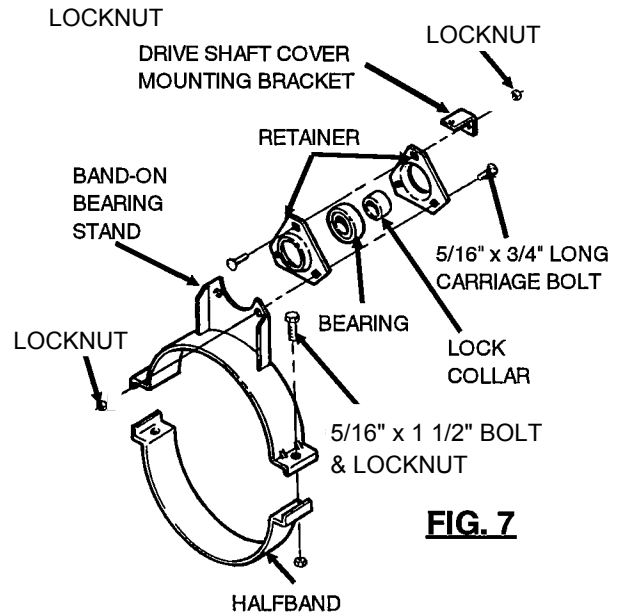

**FIG. 7**

## EXTENSION DRIVE SHAFTS

1. Slide bearing stands onto extension drive shaft. Attach the extension drive shaft to the auger drive shaft using a coupler and two 1/4" x 1 1/2" square keys (See Fig. 8).

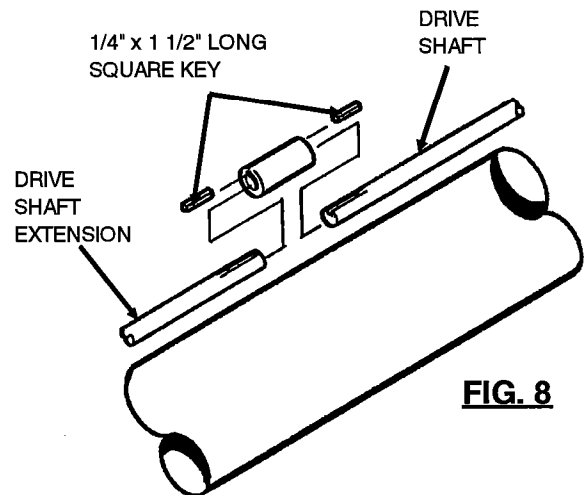

**FIG. 8**

# ASSEMBLY INSTRUCTIONS

## GEARBOX ASSEMBLY

Gearboxes are equipped with two oil fill plugs and may be shipped without oil. One plug is vented and must always be on the top side of the gearbox.

**IMPORTANT: ADD 90 EP (non-foaming) oil until the gearbox is half full.**

For top mount electric or PTO drive augers, attach gearbox to band-on mount with four  $3/8" \times 3/4"$  bolts and lock washers (See Fig. 9).

For underslung gas engine Models, attach gearbox to band-on mount using  $1/2" \times 1"$  bolts and lock washers (See Fig. 10).

Set gearbox on auger and connect to drive shaft with coupler and two  $1/4" \times 1 1/2"$  square keys (See Fig's. 9 & 10).

Secure gearbox mount to auger housing using half-band and six  $5/16" \times 1 1/2"$  bolts and locknuts for the PTO and top mount electric models (See Fig 9), and six  $5/16" \times 1 3/4"$  bolts and locknuts for the underslung gas models (See Fig. 10).

Attach drive shaft cover bracket to top of gearbox with two  $3/8" \times 3/4"$  bolts and lock washers for PTO & top mount electric Models (See Fig. 9) and two  $1/2" \times 3/4"$  bolts and lock washers for underslung gas Models (See Fig. 10).

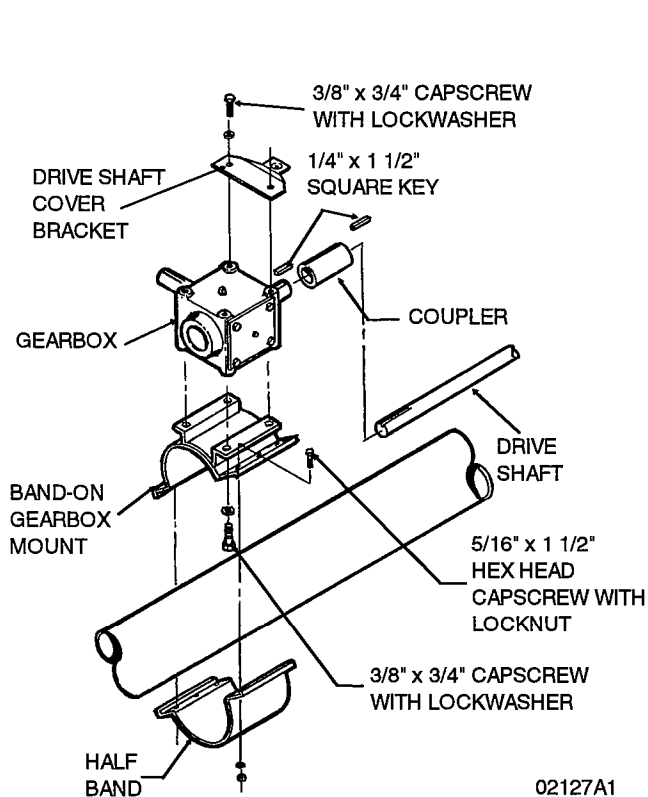

**FIG. 9**

**PTO DRIVE & TOP  
MOUNT ELECTRIC  
DRIVE AUGERS**

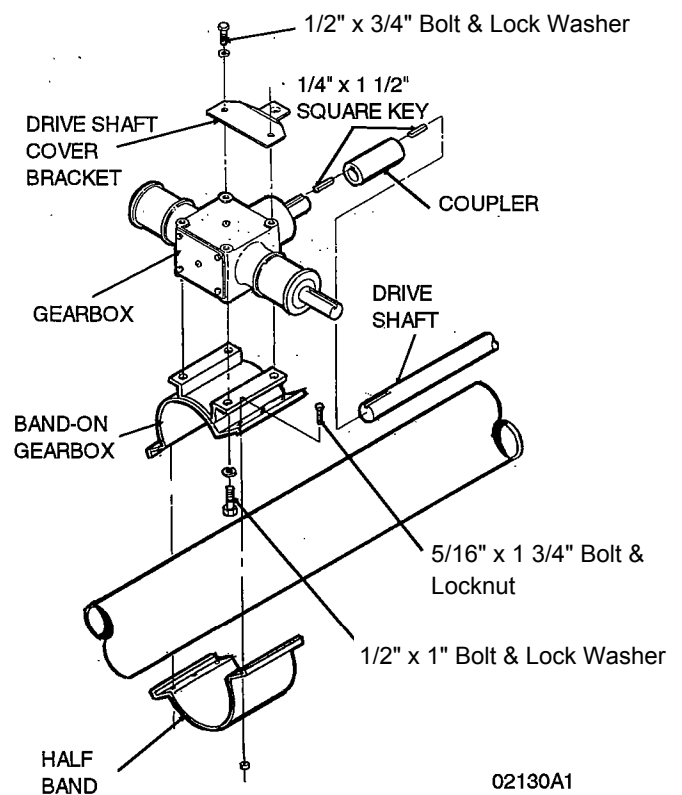

**FIG. 10**

**UNDERSLUNG  
GAS ENGINE  
DRIVE AUGERS**

# ASSEMBLY INSTRUCTIONS

## DRIVE SHAFT COVERS

The covers should be placed on the auger before the undercarriage is installed. **PLEASE REMEMBER THESE COVERS PROVIDE IMPORTANT PROTECTION FOR PERSONS AROUND AN AUGER THAT IS IN OPERATION.** Proper installation is important. The locations of the various lengths of drive shaft covers are shown in Figures 12, 13 & 14 on the following pages, depending on how the auger is driven.

There is a special section of drive shaft cover that installs between the gearbox and the first bearing stand. The special cover has retaining bottom edges to enable the next section of cover to "telescope" within it, thus allowing a variance in length.

To install it, slide these first two sections together. See Fig. 11. Align the slot in the special cover with the hole in the gearbox bracket. With a 1" O.D. flat washer over the slot, drive a self tapping slotted head screw through into the bracket, being careful not to overtighten and strip out the bracket hole. In a similar manner, attach the other end, along with the next drive shaft cover, to the first bearing stand bracket. **NOTE:** If it is a band-on bearing stand, be sure it is placed as recommended on the following pages. **CAUTION: THE TWO PIECE TELESCOPING COVER SHOULD OVERLAP AT LEAST 6" FOR PROPER FIT.**

Install remaining covers as described above, overlapping them as shown.

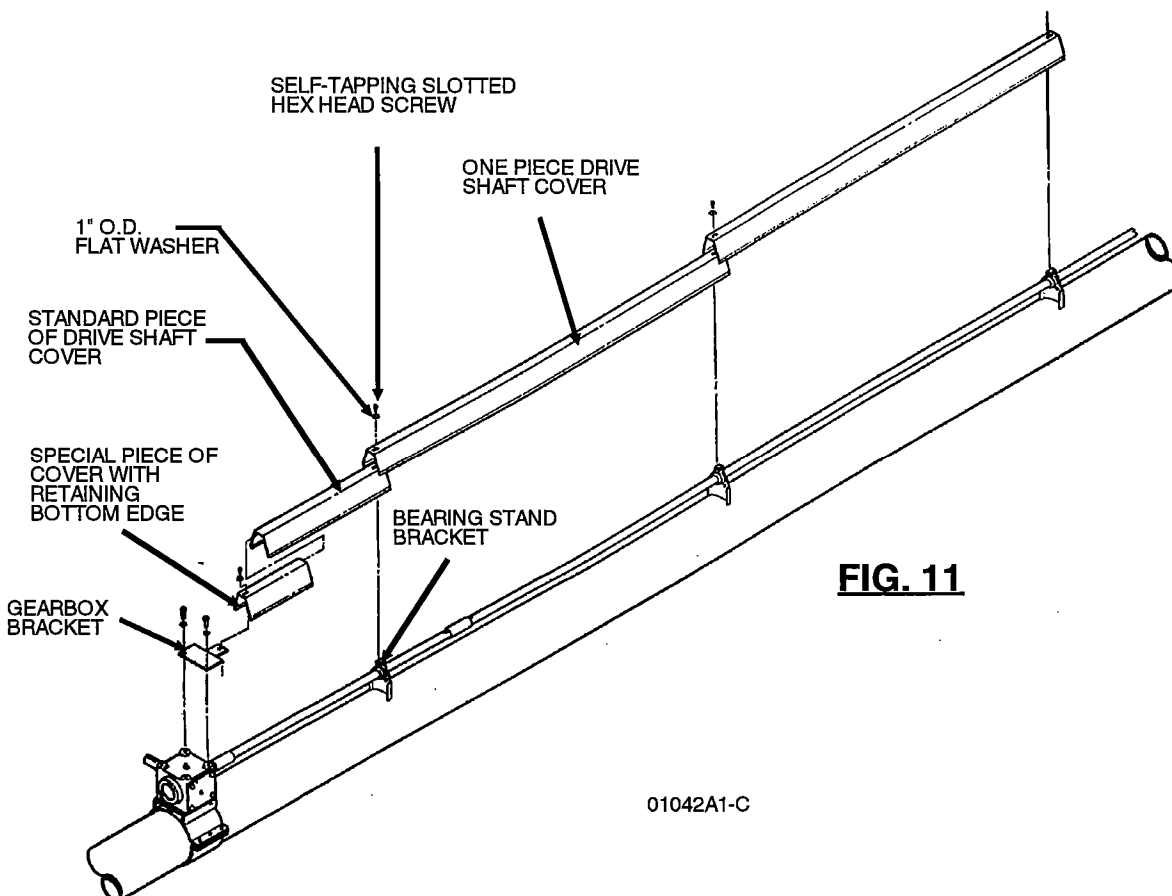

# ASSEMBLY INSTRUCTIONS

**NOTICE - The illustration on this page applies to PTO Driven Augers ONLY.**

**DO NOT operate auger without all drive shaft covers in place.**

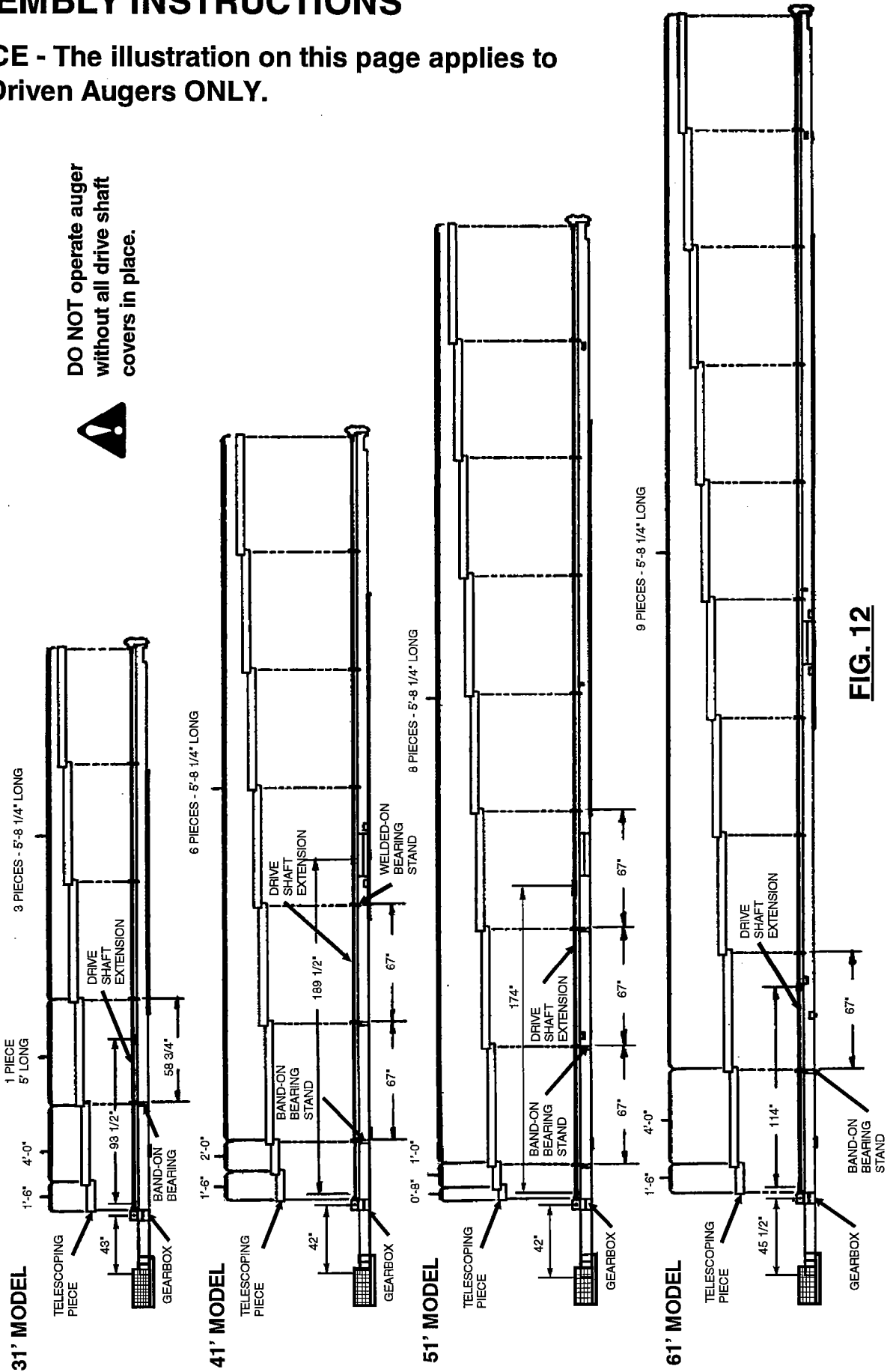
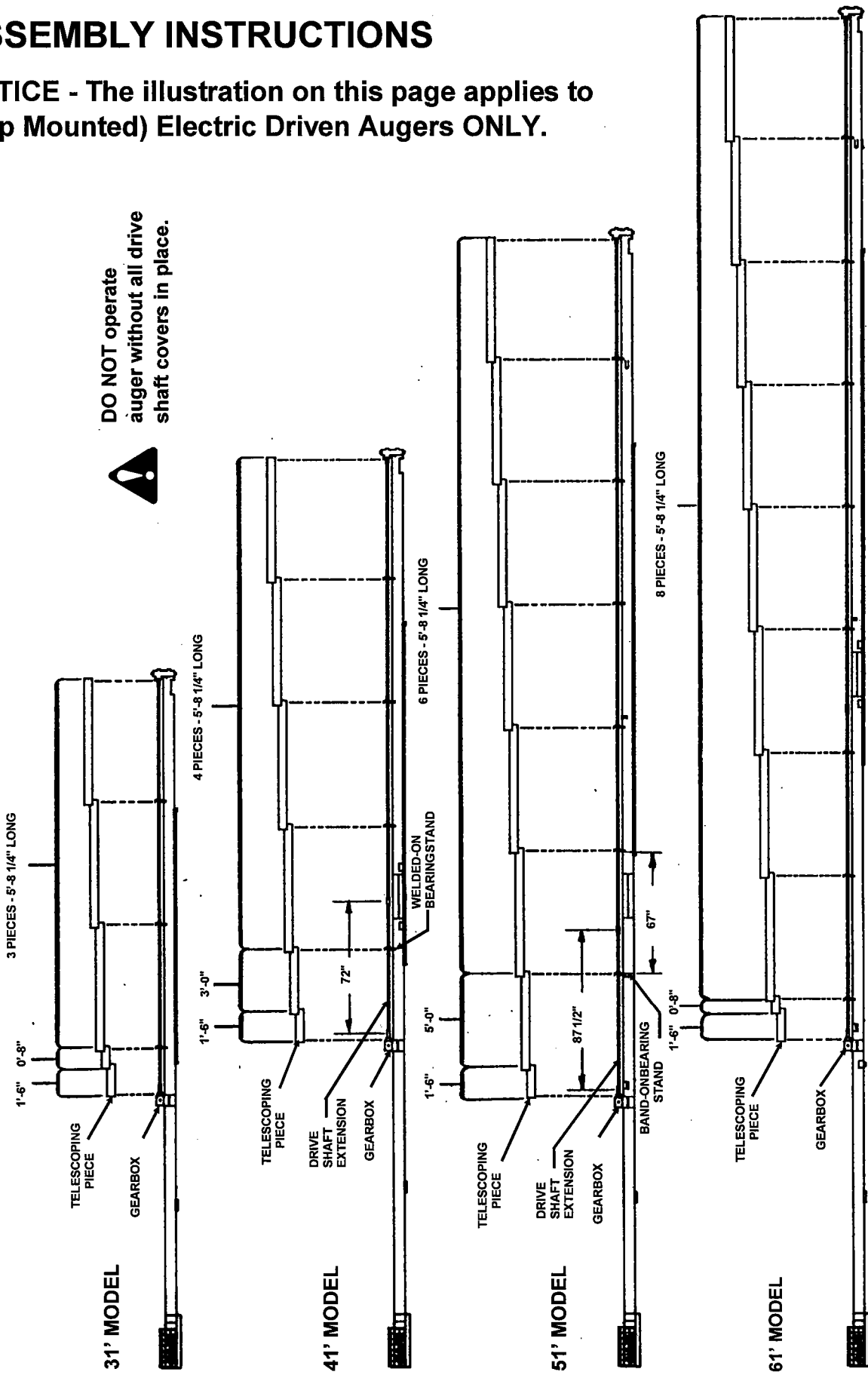

**FIG. 12**

# ASSEMBLY INSTRUCTIONS

**NOTICE - The illustration on this page applies to (Top Mounted) Electric Driven Augers ONLY.**

**DO NOT** operate auger without all drive shaft covers in place.

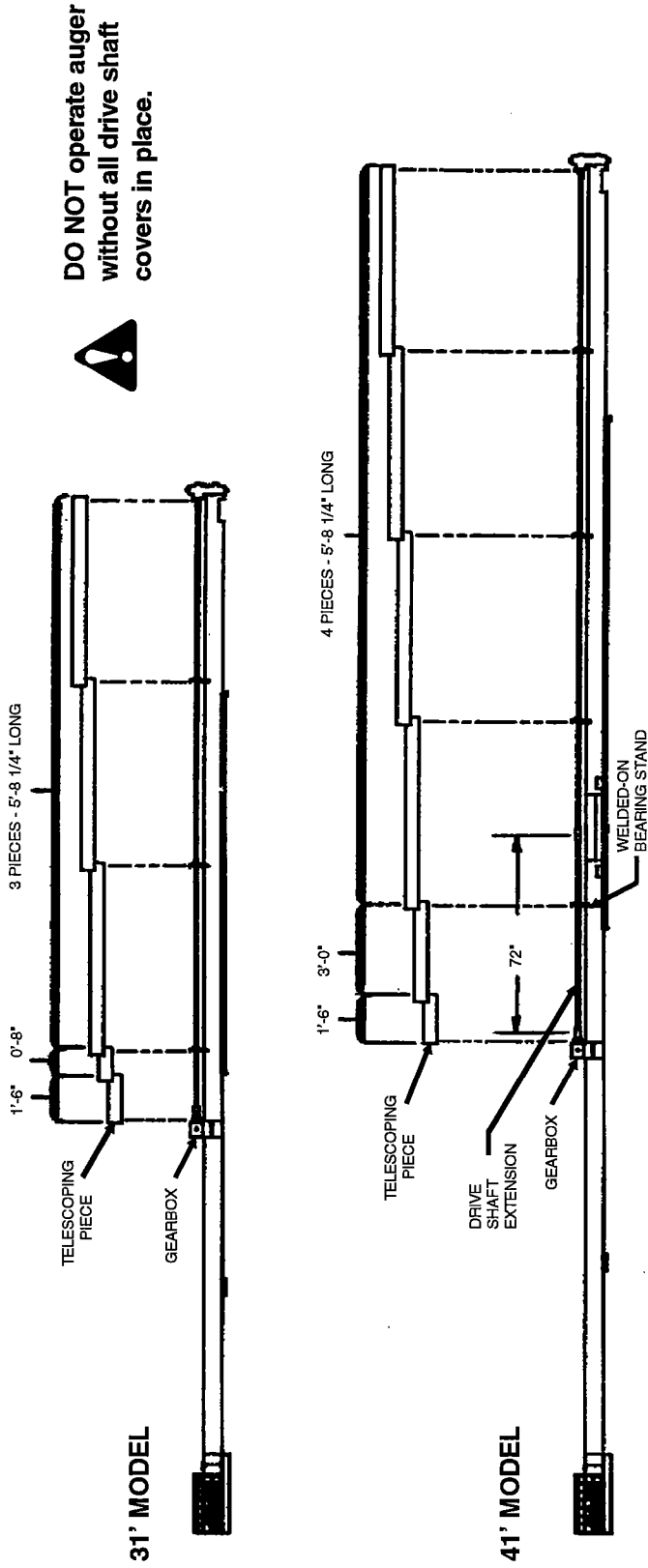

**FIG. 13**

# ASSEMBLY INSTRUCTIONS

**NOTICE - The illustration on this page applies to Underslung Gas Engine Driven Augers ONLY.**

A0003270



**FIG. 14**

# ASSEMBLY INSTRUCTIONS

## TOP TRUSS - 41' thru 61' AUGERS

To assemble the center truss, attach the two vertical tubes to the truss mounts on the auger tube using 5/8" x 1 1/2" bolts and locknuts (only finger tight), See Fig. 15, Detail A.

Loosely attach the truss top crossmember to the vertical tubes using 5/8" x 1 1/2" bolts and locknuts as shown in Fig. 15, with cable clips in place. The bolts must go through the tube from the top.

Attach cables to upper cable anchor (at discharge end) using 2 cable clamps for each connection. The u-bolt part of the clamp should be against the short end of the cable.

Run the cables over the center truss. Attach using cable clips, but **DO NOT** tighten clips at this time.

Install eyebolts through anchor at intake end, using flat washer and two nuts. (See Fig. 15, Detail B.)

Attach a cable to each eyebolt using two cable clamps with the clamp u-bolt against the short end of the cable. Use the eyebolts to remove slack from the cable so it is reasonably snug. Tighten both cables equally. **DO NOT** over tighten.

Adjust the vertical truss tubes perpendicular to the tube. Tighten the cable clips on top to hold the cable in place. Tighten the bolts holding the truss assembly to the tube.

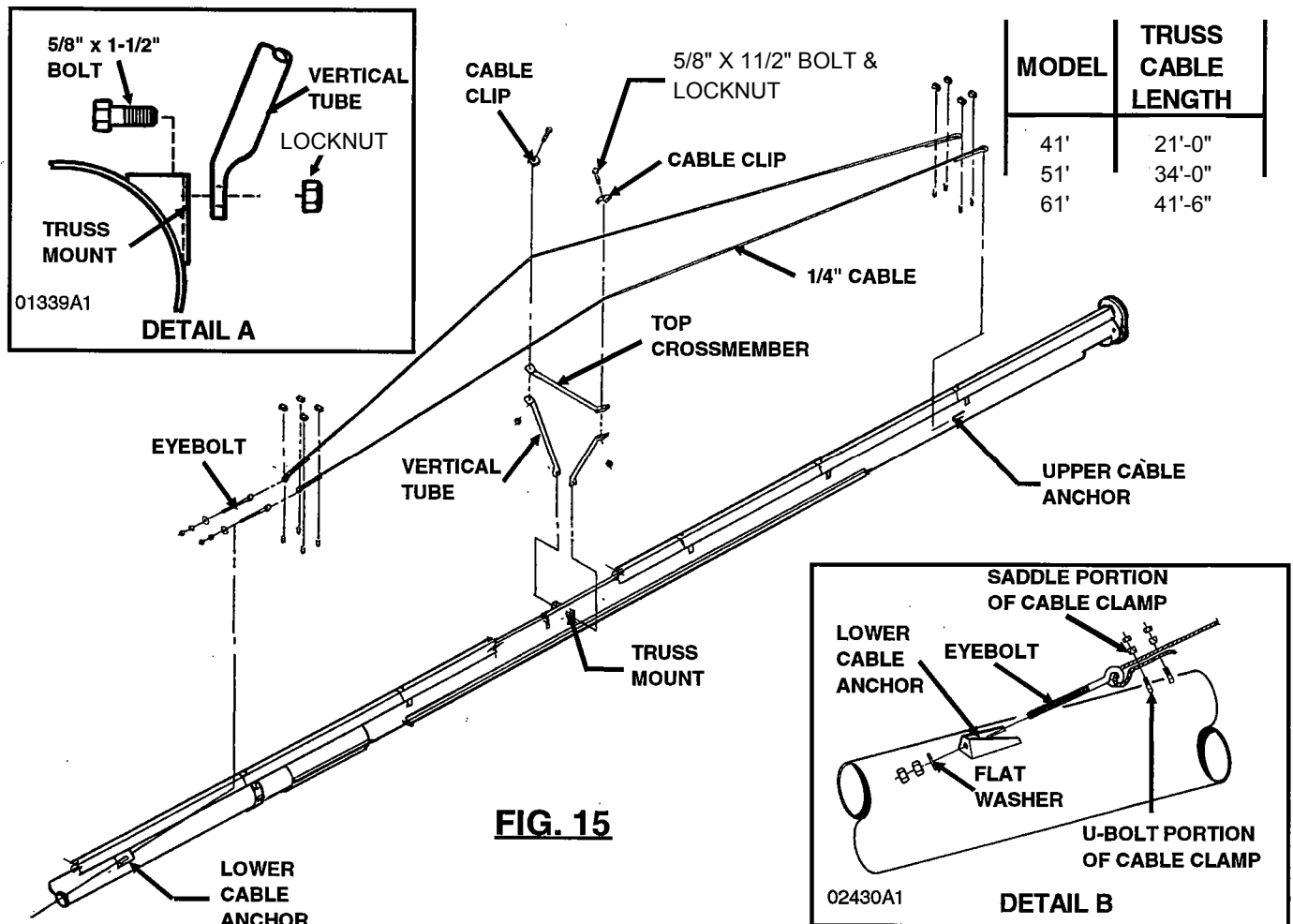

# ASSEMBLY INSTRUCTIONS

## ENCLOSED DRIVE

The enclosed drive is located at the discharge end of the auger housing and may be shipped without oil. Oil may need to be added to the unit during assembly. Add 1 1/2" pints of EP (non-foaming) oil or until the level of the oil reaches the check port (See Fig. 16).

**DO NOT ADD MORE OIL THAN RECOMMENDED.**

**OVERFILLING MAY DAMAGE THE SEALS OR FORCE OIL OUT THROUGH THE VENTED PLUG.**

For lubrication and maintenance information, see page 14.

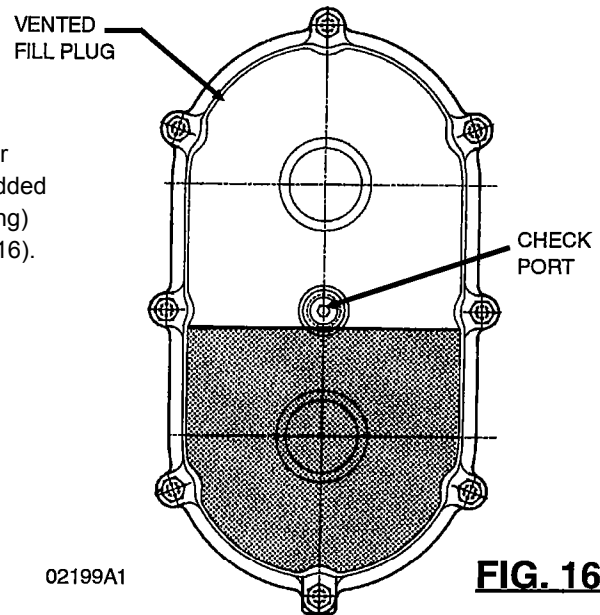

**FIG. 16**

## HUB AND SPINDLE TO UNDERCARRIAGE ASSEMBLY

The 4 bolt hubs, bearings, seals and spindles are assembled at the factory and are pressure packed with grease at that time.

Slide the 4 bolt hub and spindle assembly into the undercarriage axle and secure with bolt and locknut. See Fig. 17.

Secure tire and rims to hubs with lug bolts.

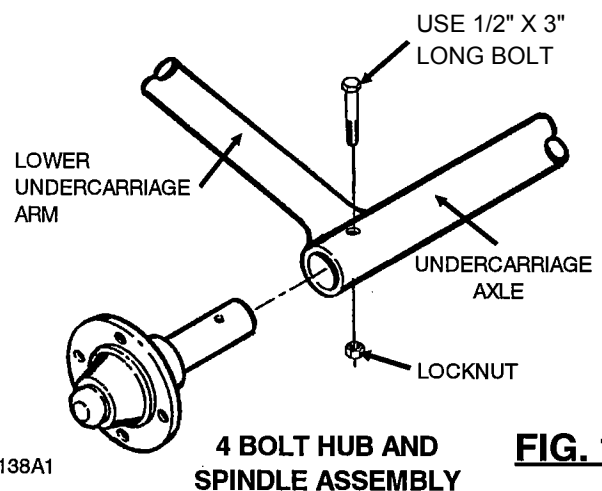

**FIG. 17**

## UNDERCARRIAGE SLIDE TO TRACK ASSEMBLY

Remove the stop bolted to the discharge end of the undercarriage track. See Fig. 19, page 26. Lift the auger assembly a few feet by lifting at a point near the center of the auger with a chain hoist or other safe, suitable means. **DO NOT** lift the entire weight of the auger from the extreme end. **DO NOT** use drive shaft to lift auger. Use a sling completely around auger tube assembly for lifting. Install the undercarriage slide onto the track from the discharge end. Be sure the undercarriage is installed on the track in a way that it cannot be removed from the track after the stop has been reinstalled. See Fig. 18.

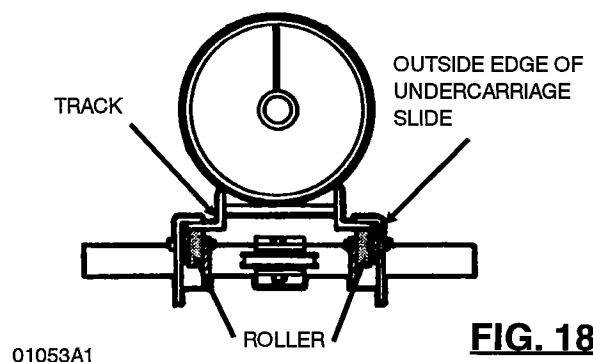

**FIG. 18**

# ASSEMBLY INSTRUCTIONS

## UNDERCARRIAGE STOP TO TRACK ASSEMBLY

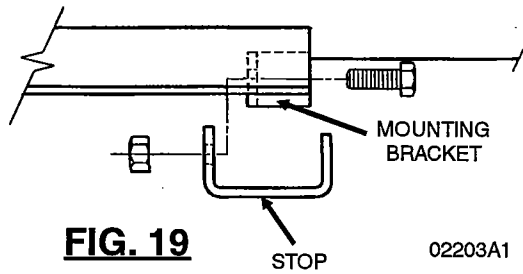

The stop must be replaced on the track after the undercarriage slide is installed. It is **IMPORTANT** that the stop be bolted on the **inside** of the mounting bracket. Use two 3/8" x 1" hex head bolts and locknuts.

## LOWER UNDERCARRIAGE ARM TO MOUNT ASSEMBLY

Bolt the lower arm of the undercarriage to the auger. Use a 4" wide half band and four 5/16" x 1-1/2" bolts and nuts on 31', 41' & 51' models. Use two 4" wide half bands and eight 5/16" x 1-1/2" bolts and nuts for 61' models. See chart below to determine location for mounting. These measurements should place the halfband just above the welded stop. See Fig. 20.

AUGER SIZE	DISTANCE "A" TO END OF TUBE
31'	88 1/2"
41'	111 5/8"
51'	139 5/8"
61'	183 5/8"

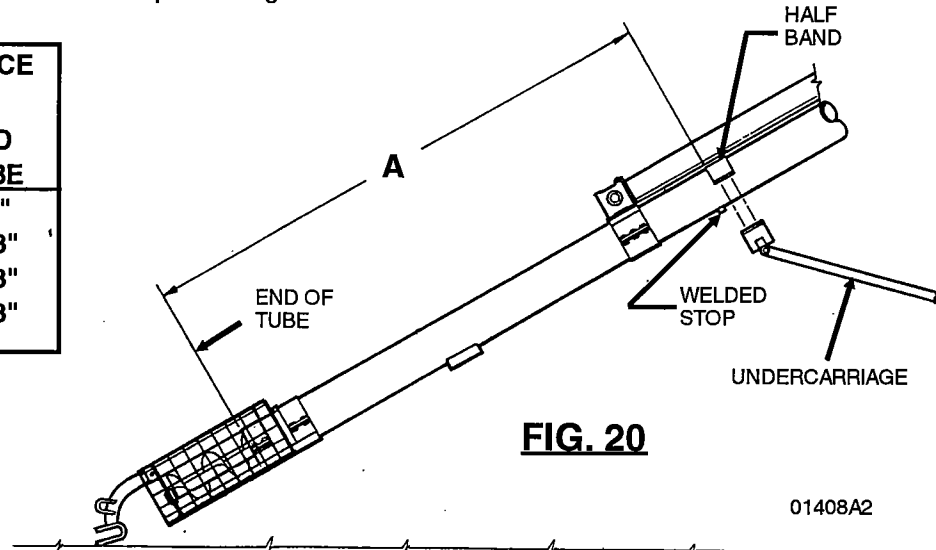

## BOTTOM TRUSS ASSEMBLY FOR 61' MODEL ONLY

1. Install center stand-off support to bottom side of auger track at the intake end, See Fig. 21.
2. Attach 1/4" cable to upper anchor. Using an overhand knot and two cable clamps, secure the clamp u-bolt against the short end of the cable, See Detail B of Fig. 22 on following page.
3. Thread cable through the pipe on the center stand-off support, See Detail A of Fig. 22.
4. Install eyebolt in lower anchor pipe on lower tube section using 1/2" flat washer and two nuts, See Detail C of Fig. 22.
5. Fasten cable to eyebolt by using an overhand knot and two cable clamps. Attach the clamp u-bolt against the short end of the cable, See Detail C of Fig. 22. Use eyebolt to tighten cable enough to remove "sag" from auger assembly. DO NOT over tighten.

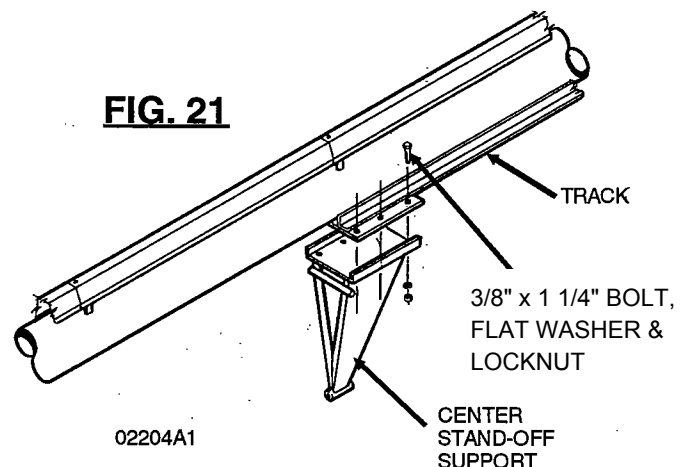

# ASSEMBLY INSTRUCTIONS

## BOTTOM TRUSS ASSEMBLY FOR 61' MODELS ONLY - (cont'd.)

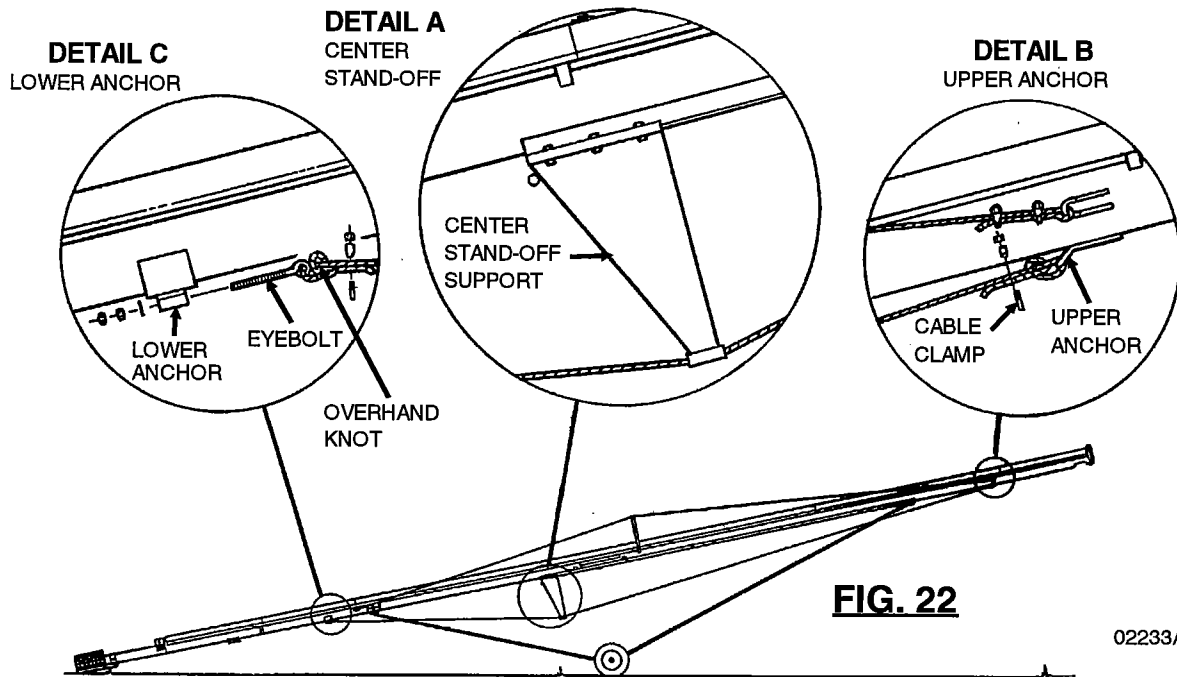

### WINCH HANDLE ASSEMBLY

31', 41' & 51' AUGERS (K-1051 WINCH)  
61' AUGERS (K1550 WINCH)

Align slot of handle with flat portion of winch pinion shaft. Use hex nut to hold handle in place and tighten securely. See Fig. 23. For additional winch information, follow the instructions and precautions listed in the material supplied with the winch from the manufacturer.

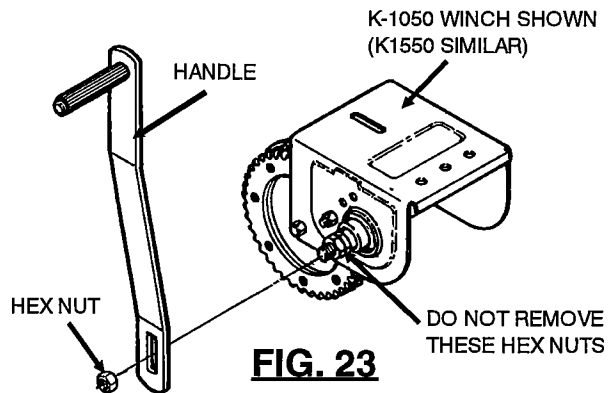

### CABLE TO WINCH ASSEMBLY

On 31', 41', 51' & 61' augers attach a 1/4" lift cable to the winch drum so the cable will wrap under the winch drum when turning handle in a clockwise direction. From inside the drum, insert the cable through one round hole in the drum side, until it extends 1" past the two square holes. Next clamp the cable to the outside of the drum with the cable keeper, using two 3/16" x 3/4" carriage bolts, lock washers and nuts. Be sure that the carriage bolt heads are on the inside of the drum. See Fig. 24.

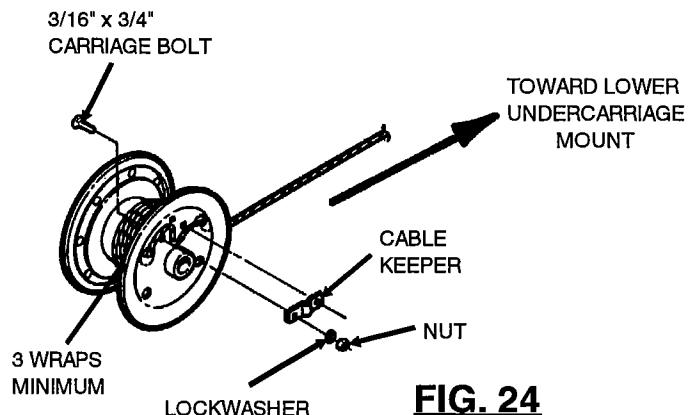

**Never fully extend the cable and always keep three complete turns of cable around winch drum.**

# ASSEMBLY INSTRUCTIONS

## WINCH TO AUGER ASSEMBLY

Bolt the winch assembly to the winch mount with the drum toward the auger discharge. Use three 3/8" x 1" bolts, flat washers and locknuts, See Fig. 25.

WINCH LOCATION	
UNIT SIZE	A
6" x 31'	70"
6" x 41'	79"
6" x 51'	70"
6" x 61'	73"

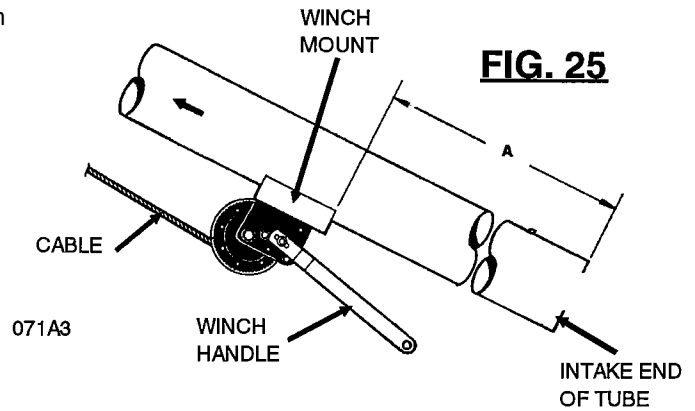

## WINCH CABLE ASSEMBLY

Attach the winch lift cable according to the illustration below. Secure the cable with two cable clamps making sure the u-bolt is against the short end of the cable.

CABLE LENGTHS	
MODEL	CABLE
31'	21'
41'	28'
51'	54'
61'	70'

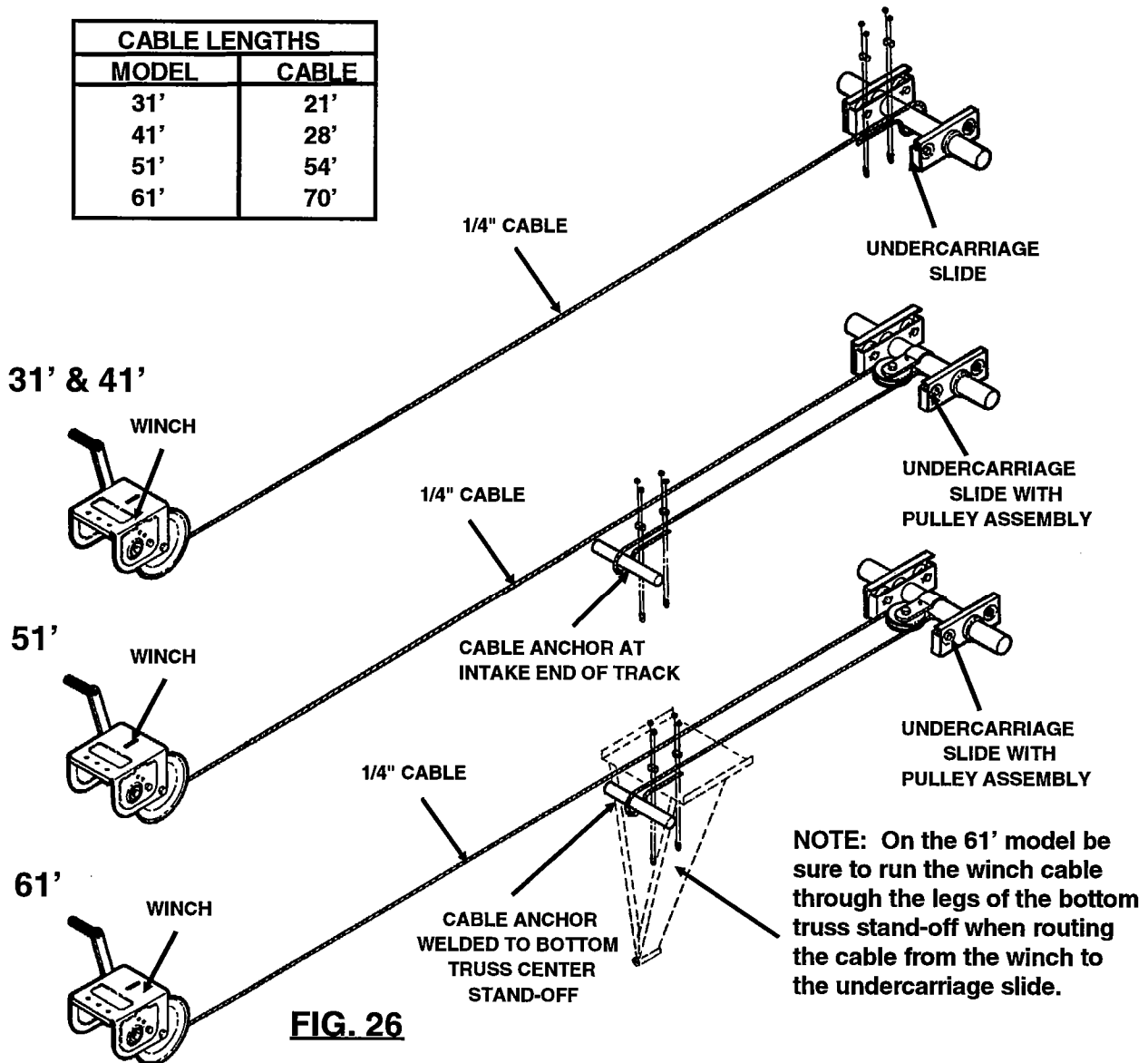

**NOTE:** On the 61' model be sure to run the winch cable through the legs of the bottom truss stand-off when routing the cable from the winch to the undercarriage slide.

# ASSEMBLY INSTRUCTIONS

## DIRECT P.T.O. DRIVE ASSEMBLY

**NOTE:** The P.T.O. Drive can be placed on either the right-hand or left-hand side of the auger. The following illustrations show the gearbox in a left-hand position.

Step 1. With 1/4" x 1-1/2" key, slide the PTO driveline yoke onto the gearbox shaft until the shaft end is flush with the inside edge of the yoke. This is important for the setscrew to seat properly. See Detail A below.

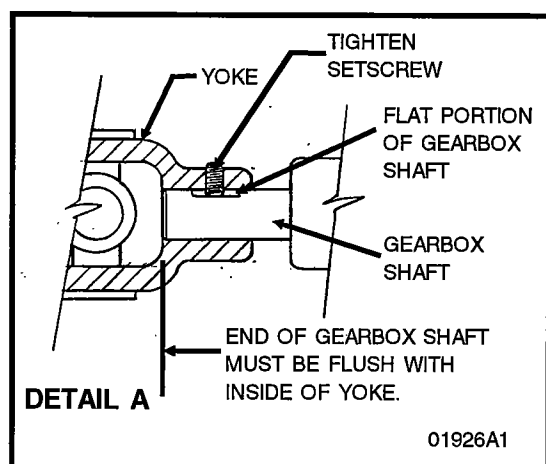

**Before engaging P.T.O. be sure that P.T.O. driveline shields turn freely on the shaft.**

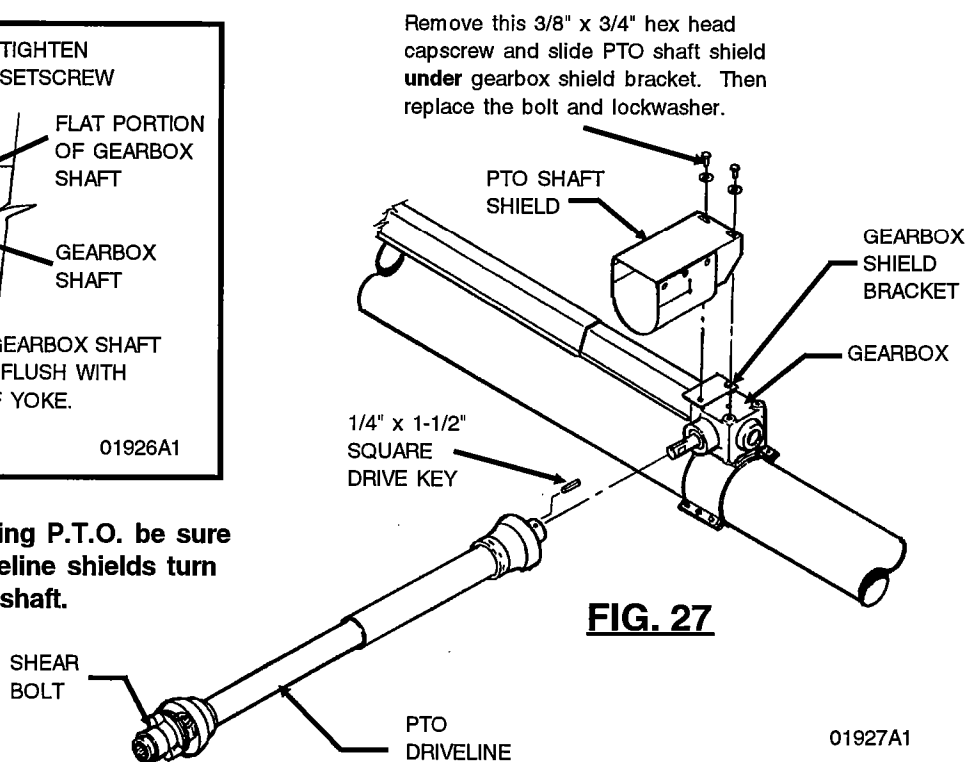

Step 2. Then install the PTO shaft shield over the shaft/gearbox coupling. See Figure 27.

Step 3. See chart on page 30 for the location of the PTO driveline support. Bolt the driveline support in place using a half band. Position PTO the support so the driveline will be parallel with the drive shaft covers. See Fig. 28. Install retaining pin by slipping the short bent end of the pin through the hole in the driveline support and then through the slot on the other side. Allow the long end of the pin to rotate down --this will secure the pin. Set the PTO driveline into the support to be sure the support is installed correctly. See Fig. 28 on page 30.

**NOTE:** The PTO driveline is equipped with a shear bolt at the tractor end. The shear bolt protects the auger from damage should it become plugged or subjected to too high a load. It is important to use a replacement bolt of the proper size and strength to insure that the shear device will protect the auger and operator.

Order replacement shear bolt, Part No. 33046 - 5/16"- 18 x 1" long Grade 5 bolt.

**NOTE:** To change the drive for a right hand drive, turn the gearbox over and bolt the other side to the gearbox mount. The vent plug in the gearbox must be put on the top side of the box. The input driveline support is installed on the other side of the tube.

# ASSEMBLY INSTRUCTIONS

## DIRECT P.T.O. DRIVE ASSEMBLY - (cont'd.)

**IMPORTANT:  
DO NOT INSTALL  
THE SUPPORT  
WHERE THE  
BANDS WILL  
COVER ANY  
SAFETY SIGNS  
ON THE AUGER  
HOUSING.**

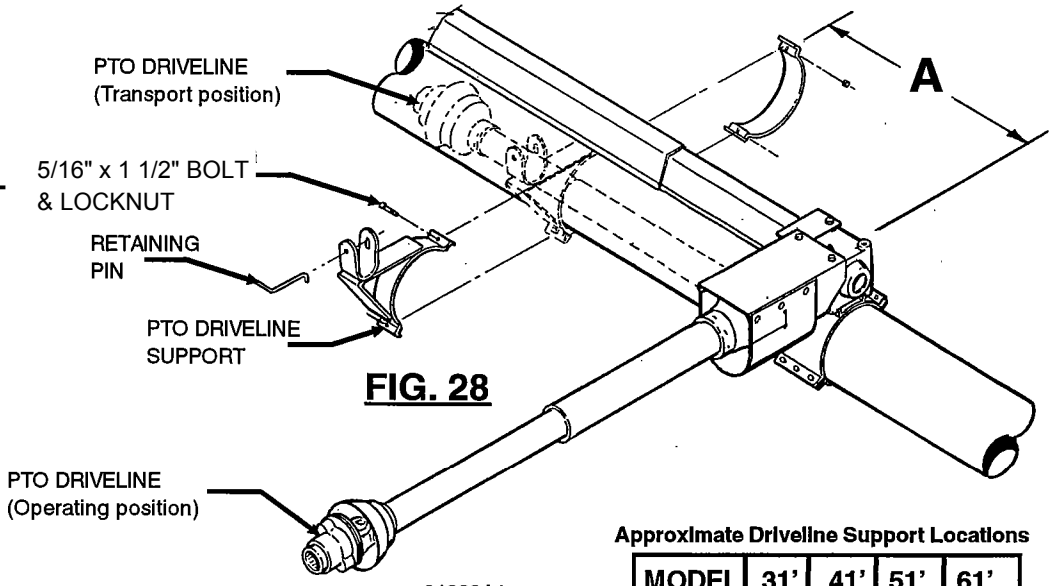

**FIG. 28**

Approximate Driveline Support Locations

MODEL	31'	41'	51'	61'
A	54"	59"	59"	54"

01929A4

## TOP MOUNT ELECTRIC DRIVE ASSEMBLY

Assemble electric motor mount as shown in Figure 29. See Pages 9 & 10 for correct motor and motor sheave size.

**Keep all safety shields and devices in place.**

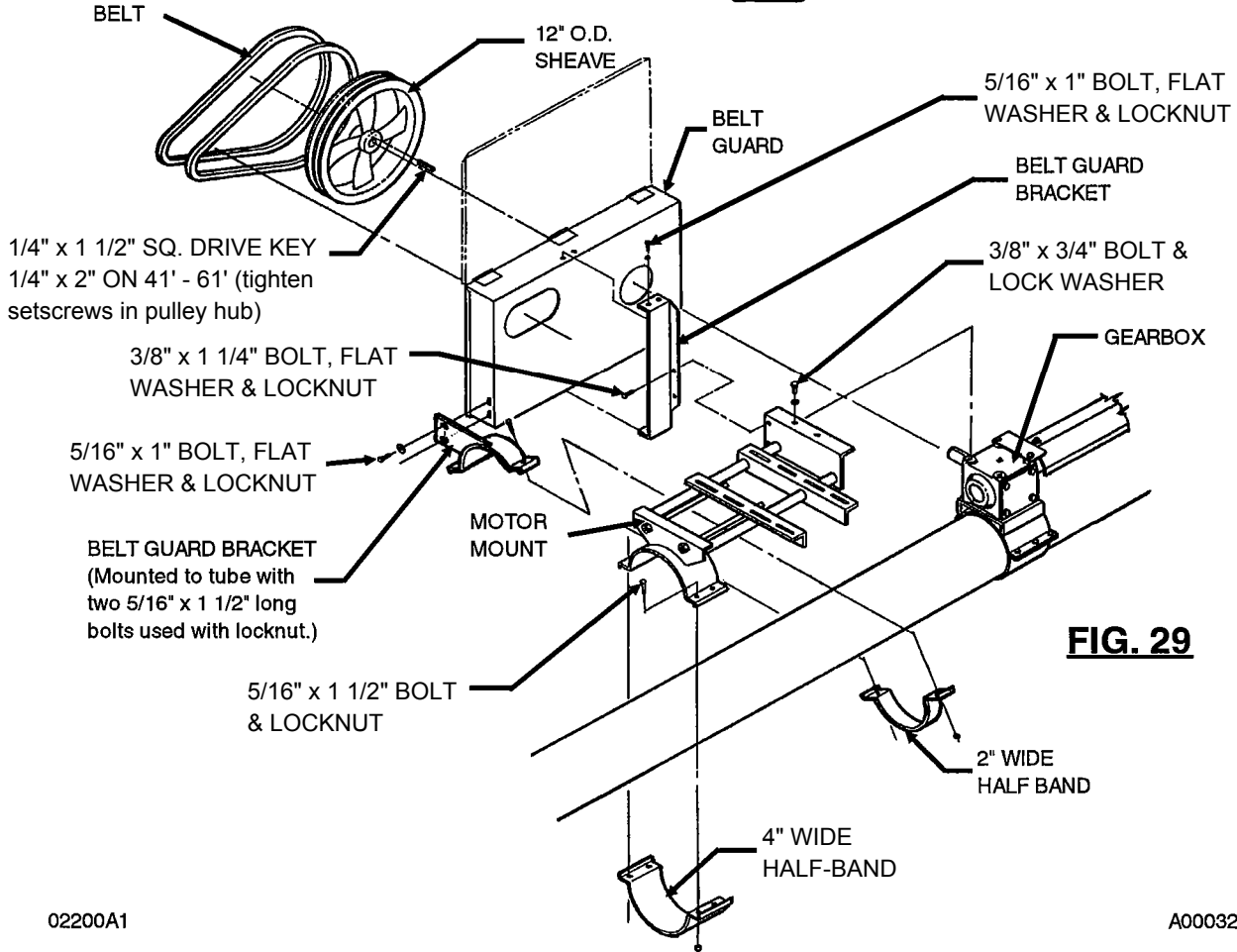

**FIG. 29**

# ASSEMBLY INSTRUCTIONS

## UNDERSLUNG GAS ENGINE DRIVE ASSEMBLY

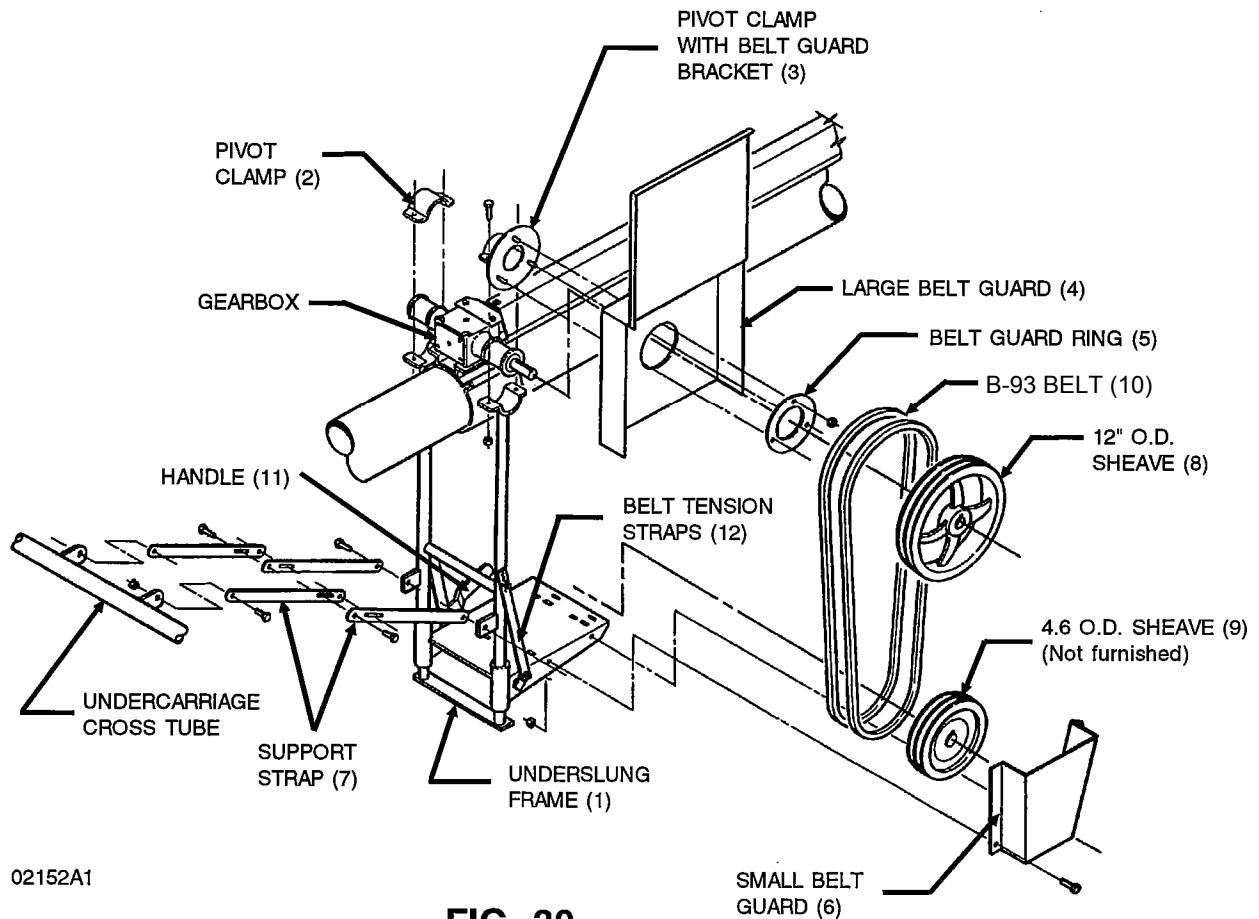

02152A1

**FIG. 30**

1. Mount the underslung frame (1) to the gearbox pivot ears by using pivot clamps (2) & (3) and four 3/8" x 1-1/4" hex head capscrews with locknuts.
2. Attach two support straps (7) to the back of underslung frame (1) using 3/8" x 1" hex head capscrews and locknuts. Then attach two support straps (7) to the ears on the undercarriage cross tube using the same hardware.
3. Connect the support straps together using two 3/8" x 1" hex head capscrews and locknuts per each set of straps. Adjust the support straps so the motor mount sets level to the ground.
4. Use a belt guard ring (5) and three 3/8" locknuts to fasten the large belt guard (4) to the pivot clamp (3). The large belt guard (4) should be free to pivot on the three bolts.  
**DO NOT COMPLETELY TIGHTEN THE LOCKNUTS DOWN AT THIS TIME.**
5. Install the 12" O.D. sheave (8) to gearbox shaft using a 1/4" x 2" long square drive key. Tighten setscrews in sheave hub.

# ASSEMBLY INSTRUCTIONS

## UNDERSLUNG DRIVE ASSEMBLY - (cont'd.)

6. Mount gas engine and engine sheave. **SHEAVE NOT FURNISHED.** See page 10 for engine and engine sheave specifications.
7. Align sheaves by using a straight edge placed across the outer faces of both sheaves. Install belts (10). To check belt tension, first engage the motor mount handle (11) by rotating it down until the handle locks over center. Belts should be snug. To adjust the belts, disengage the motor mount handle (11) by rotating up. Vary the belt tension by using the holes in the top of the belt tension straps (12) located on both sides of the underslung frame. Check belt tension again after adjustment has been made.

**DO NOT OVERTIGHTEN THE BELTS. EXCESSIVE WEAR OR DAMAGE WILL OCCUR.**

8. Mount the small belt guard (6) to the underslung frame (1) using two 5/16" x 3/4" hex head capscrews with locknuts.
9. Adjust the large belt guard (4) so it is not rubbing on the belts and tighten the three 3/8" locknuts from step 4 to hold it in place.

## TO DEALER/ASSEMBLER

The assembly of the auger is complete if all the applicable assembly steps in this manual have been followed.

Before delivery to the owner it is a good practice to check the following:

- a. Be sure all safety shields and devices are installed properly.
- b. Check all safety decals to see if they are clean and readable. If any are missing, damaged, painted over, etc. replace them. See page P-1 and P-2 for safety sign location. Decals may be obtained from your dealer, distributor or ordered from the factory.
- c. Check all bolts and fasteners to see they are tightened and secured properly.

## TO THE OWNER

Use the Assembly Section of this manual as a reference to determine that the auger is assembled properly.

**Make sure an Operator's Manual is delivered along with the auger. Anyone who will operate or work around a portable auger shall first read the Operator's Manual! Failure to read the manual and its safety instructions is a misuse of the equipment.**

# 6" TD-PLUS / CENTURY II

## SAFETY SIGNS & DECALS

Check all safety signs and replace any that are worn, missing or illegible. The safety sign locations are shown below. Copies of the safety signs are shown on page P-2. Safety signs may be obtained from your dealer or ordered from the factory.

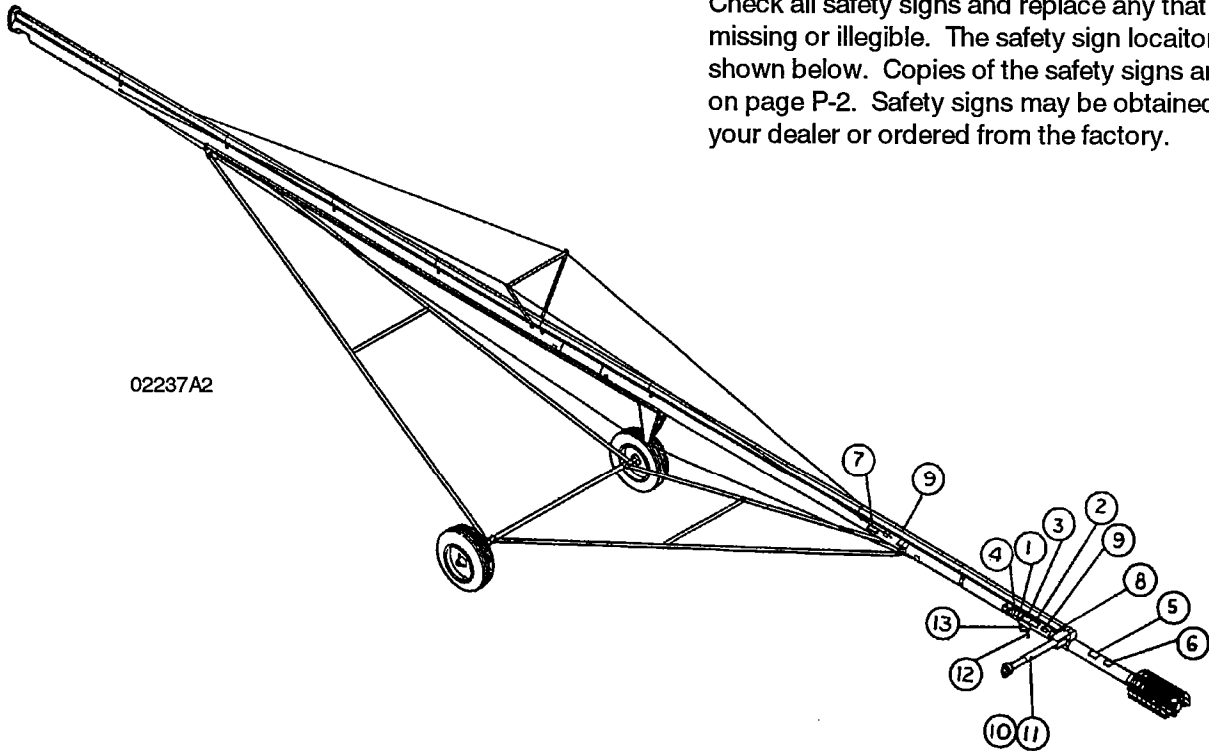

02237A2

REF. NO.	PART NO.	QTY.	DESCRIPTION	SIZE
1	1001973	1	<b>CAUTION - GENERAL STATEMENTS 1-8</b> One on side of Auger Housing	4 3/4" x 8"
2	1001980	1	<b>DANGER - BEWARE OF POWER LINES</b> One on side of Auger Housing	4" x 8"
3	1001978	1	<b>WARNING - HAND WINCH OPERATION</b> One on Auger Housing	4" x 7 1/4"
4	1005324	1	<b>DANGER "STOP" DECAL</b> One on side of Auger Housing	4" x 6"
5	1001981	1	<b>DANGER - UPENDING HAZARD</b> One on Auger Housing	4 1/2" x 6 1/4"
6	1001985	1	<b>DANGER - ROTATING AUGER</b> One on Auger Housing	4 1/2" x 6 1/4"
7	1001984	1	<b>DANGER - DO NOT ATTEMPT DISASSEMBLY</b> One on side of Auger Housing	4" x 6"
8	1001983	1	<b>DANGER - ROTATING DRIVELINE</b> One on side of Auger Housing	4" x 6 1/4"
9	1001982	2	<b>DANGER - ROTATING SHAFT</b> One on both sides of Auger Housing	4" x 7 1/4"
10	13-10022	1	<b>DANGER - SHIELD MISSING</b> Under Input Driveline Shield	---
11	13-10021	1	<b>DANGER - ROTATING DRIVELINE</b> On Input Driveline Shield	3 1/2" x 5"
12	2169A1	1	<b>CAUTION - WINCH OPERATION</b> On Hand Winch Handle	---
13	1002805	1	<b>CAUTION - CABLE OUT/CABLE IN</b> On Hand Winch Body	---

SAFETY SIGNS & DECALS

**1**

**CAUTION**

1. READ AND UNDERSTAND THE OPERATOR'S MANUAL BEFORE OPERATING.
2. DO NOT REMOVE OR MODIFY ANY GUARDS.
3. MAKE CERTAIN EVERYONE IS CLEAR BEFORE OPERATING OR MOVING THE MACHINE.
4. KEEP HANDS, FEET, HAIR AND CLOTHING AWAY FROM MOVING PARTS.
5. STOP MACHINE AND LOCKOUT POWER TO ADJUST, SERVICE OR CLEAN.
6. EMPTY MACHINE AND LOWER TO TRANSPORT POSITION FOR TRANSPORTING.
7. DO NOT ATTEMPT TO MOVE MACHINE MANUALLY. USE A TOWING VEHICLE.
8. KEEP CHILDREN WELL CLEAR OF WORK AREA.

1001978

**8**

**DANGER**



**ROTATING DRIVELINE**

- KEEP BODY, HAIR AND CLOTHING AWAY FROM ROTATING DRIVELINE.
- USE ONLY WITH AGRICULTURAL TRACTOR HAVING 540 RPM POWER TAKE OFF.
- KEEP ALL DRIVELINE, TRACTOR AND EQUIPMENT GUARDS IN PLACE.
- MAKE SURE DRIVELINES ARE SECURELY ATTACHED AT BOTH ENDS.
- MAKE SURE DRIVELINE SHIELDS TURN FREELY ON DRIVELINE.
- KEEP U-JOINT ANGLES SMALL AND EQUAL.
- KEEP CHILDREN WELL CLEAR OF WORK AREA.

FAILURE TO HEED WILL RESULT IN SERIOUS INJURY OR DEATH!

1001980

**6**

**DANGER**

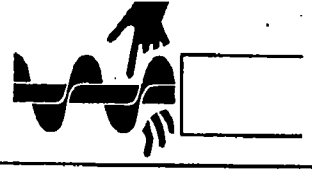

**ROTATING AUGER**

- KEEP HANDS, FEET, HAIR AND CLOTHING AWAY FROM ROTATING AUGER.
- DO NOT REMOVE OR MODIFY ANY GUARDS.
- KEEP CHILDREN WELL CLEAR OF WORK AREA.

FAILURE TO HEED WILL RESULT IN SERIOUS INJURY OR DEATH!

1001982

**2**

**DANGER**

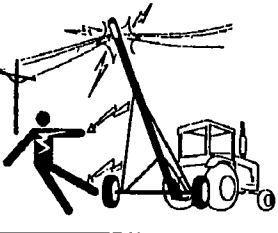

**BEWARE OF POWER LINES  
ELECTROCUTION HAZARD**

- THIS MACHINE IS NOT INSULATED.
- KEEP AT LEAST 10 FEET AWAY FROM OVERHEAD ELECTRICAL WIRES.
- ELECTROCUTION CAN OCCUR WITHOUT DIRECT CONTACT.

FAILURE TO HEED WILL RESULT IN SERIOUS INJURY OR DEATH!

1001988

**9**

**DANGER**

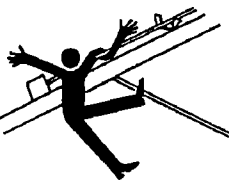

**ROTATING SHAFT**

- DO NOT REMOVE OR MODIFY ANY GUARDS.
- KEEP BODY, HAIR AND CLOTHING AWAY FROM ROTATING SHAFT.
- KEEP CHILDREN WELL CLEAR OF WORK AREA.

FAILURE TO HEED WILL RESULT IN SERIOUS INJURY OR DEATH!

1001982

**3**

**WARNING**



FOR HYDRAULIC OR ELECTRIC WINCH OPERATION, PLEASE REFER TO THE OPERATOR'S MANUAL PROVIDED WITH UNIT.

- AFTER LOWERING THE UNIT, ALWAYS TURN THE WINCH HANDLE CLOCKWISE UNTIL YOU HEAR AT LEAST TWO CLICKS. THIS TIGHTENS THE BRAKE LOCK.
- MAINTAIN CONTROL OF WINCH HANDLE AT ALL TIMES.
- DO NOT PUT LUBRICATION OF ANY KIND ON THE BRAKE DISC.
- CHECK CABLE BEFORE EACH USE. REPLACE IF FRAYED OR DAMAGED.
- MAINTAIN LIGHT CABLE TENSION WHEN TRANSPORTING.

FAILURE TO HEED WILL RESULT IN SERIOUS INJURY OR DEATH!

1001978

**7**

**DANGER**



DO NOT ATTEMPT DISASSEMBLY BEFORE SUPPORTING THE AUGER WITH AN OVERHEAD HOIST OR OTHER SAFE, SUITABLE MEANS. THE AUGER MAY COLLAPSE WHILE LOOSENING A COMPONENT IF NOT SUPPORTED.

FAILURE TO HEED WILL RESULT IN SERIOUS INJURY OR DEATH!

1001984

**5**

**DANGER**

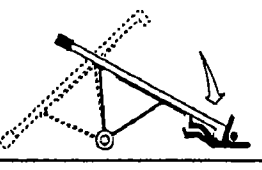

**UPENDING HAZARD**

- SUPPORT DISCHARGE END OR ANCHOR INTAKE END TO PREVENT UPENDING.
- EMPTY MACHINE BEFORE MOVING.
- DO NOT PUSH THE UNDERCARRIAGE BY HAND.
- LIFT THE INTAKE END SLOWLY AND NEVER HIGHER THAN VEHICLE TOW BAR. MAINTAIN CONTROL UNTIL SECURELY ATTACHED TO TOW BAR OR RESTING ON THE GROUND.
- LOWER TO TRANSPORT POSITION IMMEDIATELY WHEN CLEAR FROM GRAIN STORAGE STRUCTURE.

FAILURE TO HEED WILL RESULT IN SERIOUS INJURY OR DEATH!

1001981

**10**

**DANGER**



SHIELD MISSING  
DO NOT OPERATE

**DANGER**



SHIELD MISSING  
DO NOT OPERATE

**DANGER**

**11**

**DANGER**



**ROTATING DRIVELINE  
CONTACT CAN CAUSE DEATH  
KEEP AWAY!**

DO NOT OPERATE WITHOUT —

- ALL DRIVELINE, TRACTOR AND EQUIPMENT GUARDS IN PLACE
- DRIVELINES SECURELY ATTACHED AT BOTH ENDS
- DRIVELINE SHIELDS THAT TURN FREELY ON DRIVELINE

**4**

**DANGER**



IF ANY GUARDS, SHIELDS OR SAFETY DECALS ARE DAMAGED OR MISSING, ORDER FREE REPLACEMENTS BY CALLING

1-800-523-6993  
OR WRITE TO:  
HUTCHINSON/MAYRATH  
P.O. BOX 629  
CLAY CENTER, KANSAS 67432

1000394

**13**

**CAUTION**

KEEP HANDS AWAY FROM ROTATING PARTS

**12**

1. READ AND FOLLOW THE OPERATOR'S MANUAL. 2. NEVER EXCEED THE MAXIMUM OPERATING SPEED. 3. ALWAYS WEAR YOUR SEATBELT. 4. NEVER OPERATE THE MACHINE ON A SLOPE EXCEEDING THE MAXIMUM GRADE. 5. NEVER OPERATE THE MACHINE ON A SLOPE EXCEEDING THE MAXIMUM GRADE. 6. NEVER OPERATE THE MACHINE ON A SLOPE EXCEEDING THE MAXIMUM GRADE. 7. NEVER OPERATE THE MACHINE ON A SLOPE EXCEEDING THE MAXIMUM GRADE. 8. NEVER OPERATE THE MACHINE ON A SLOPE EXCEEDING THE MAXIMUM GRADE. 9. NEVER OPERATE THE MACHINE ON A SLOPE EXCEEDING THE MAXIMUM GRADE. 10. NEVER OPERATE THE MACHINE ON A SLOPE EXCEEDING THE MAXIMUM GRADE. 11. NEVER OPERATE THE MACHINE ON A SLOPE EXCEEDING THE MAXIMUM GRADE. 12. NEVER OPERATE THE MACHINE ON A SLOPE EXCEEDING THE MAXIMUM GRADE. 13. NEVER OPERATE THE MACHINE ON A SLOPE EXCEEDING THE MAXIMUM GRADE. 14. NEVER OPERATE THE MACHINE ON A SLOPE EXCEEDING THE MAXIMUM GRADE. 15. NEVER OPERATE THE MACHINE ON A SLOPE EXCEEDING THE MAXIMUM GRADE. 16. NEVER OPERATE THE MACHINE ON A SLOPE EXCEEDING THE MAXIMUM GRADE. 17. NEVER OPERATE THE MACHINE ON A SLOPE EXCEEDING THE MAXIMUM GRADE. 18. NEVER OPERATE THE MACHINE ON A SLOPE EXCEEDING THE MAXIMUM GRADE. 19. NEVER OPERATE THE MACHINE ON A SLOPE EXCEEDING THE MAXIMUM GRADE. 20. NEVER OPERATE THE MACHINE ON A SLOPE EXCEEDING THE MAXIMUM GRADE. 21. NEVER OPERATE THE MACHINE ON A SLOPE EXCEEDING THE MAXIMUM GRADE. 22. NEVER OPERATE THE MACHINE ON A SLOPE EXCEEDING THE MAXIMUM GRADE. 23. NEVER OPERATE THE MACHINE ON A SLOPE EXCEEDING THE MAXIMUM GRADE. 24. NEVER OPERATE THE MACHINE ON A SLOPE EXCEEDING THE MAXIMUM GRADE. 25. NEVER OPERATE THE MACHINE ON A SLOPE EXCEEDING THE MAXIMUM GRADE. 26. NEVER OPERATE THE MACHINE ON A SLOPE EXCEEDING THE MAXIMUM GRADE. 27. NEVER OPERATE THE MACHINE ON A SLOPE EXCEEDING THE MAXIMUM GRADE. 28. NEVER OPERATE THE MACHINE ON A SLOPE EXCEEDING THE MAXIMUM GRADE. 29. NEVER OPERATE THE MACHINE ON A SLOPE EXCEEDING THE MAXIMUM GRADE. 30. NEVER OPERATE THE MACHINE ON A SLOPE EXCEEDING THE MAXIMUM GRADE. 31. NEVER OPERATE THE MACHINE ON A SLOPE EXCEEDING THE MAXIMUM GRADE. 32. NEVER OPERATE THE MACHINE ON A SLOPE EXCEEDING THE MAXIMUM GRADE. 33. NEVER OPERATE THE MACHINE ON A SLOPE EXCEEDING THE MAXIMUM GRADE. 34. NEVER OPERATE THE MACHINE ON A SLOPE EXCEEDING THE MAXIMUM GRADE. 35. NEVER OPERATE THE MACHINE ON A SLOPE EXCEEDING THE MAXIMUM GRADE. 36. NEVER OPERATE THE MACHINE ON A SLOPE EXCEEDING THE MAXIMUM GRADE. 37. NEVER OPERATE THE MACHINE ON A SLOPE EXCEEDING THE MAXIMUM GRADE. 38. NEVER OPERATE THE MACHINE ON A SLOPE EXCEEDING THE MAXIMUM GRADE. 39. NEVER OPERATE THE MACHINE ON A SLOPE EXCEEDING THE MAXIMUM GRADE. 40. NEVER OPERATE THE MACHINE ON A SLOPE EXCEEDING THE MAXIMUM GRADE. 41. NEVER OPERATE THE MACHINE ON A SLOPE EXCEEDING THE MAXIMUM GRADE. 42. NEVER OPERATE THE MACHINE ON A SLOPE EXCEEDING THE MAXIMUM GRADE. 43. NEVER OPERATE THE MACHINE ON A SLOPE EXCEEDING THE MAXIMUM GRADE. 44. NEVER OPERATE THE MACHINE ON A SLOPE EXCEEDING THE MAXIMUM GRADE. 45. NEVER OPERATE THE MACHINE ON A SLOPE EXCEEDING THE MAXIMUM GRADE. 46. NEVER OPERATE THE MACHINE ON A SLOPE EXCEEDING THE MAXIMUM GRADE. 47. NEVER OPERATE THE MACHINE ON A SLOPE EXCEEDING THE MAXIMUM GRADE. 48. NEVER OPERATE THE MACHINE ON A SLOPE EXCEEDING THE MAXIMUM GRADE. 49. NEVER OPERATE THE MACHINE ON A SLOPE EXCEEDING THE MAXIMUM GRADE. 50. NEVER OPERATE THE MACHINE ON A SLOPE EXCEEDING THE MAXIMUM GRADE. 51. NEVER OPERATE THE MACHINE ON A SLOPE EXCEEDING THE MAXIMUM GRADE. 52. NEVER OPERATE THE MACHINE ON A SLOPE EXCEEDING THE MAXIMUM GRADE. 53. NEVER OPERATE THE MACHINE ON A SLOPE EXCEEDING THE MAXIMUM GRADE. 54. NEVER OPERATE THE MACHINE ON A SLOPE EXCEEDING THE MAXIMUM GRADE. 55. NEVER OPERATE THE MACHINE ON A SLOPE EXCEEDING THE MAXIMUM GRADE. 56. NEVER OPERATE THE MACHINE ON A SLOPE EXCEEDING THE MAXIMUM GRADE. 57. NEVER OPERATE THE MACHINE ON A SLOPE EXCEEDING THE MAXIMUM GRADE. 58. NEVER OPERATE THE MACHINE ON A SLOPE EXCEEDING THE MAXIMUM GRADE. 59. NEVER OPERATE THE MACHINE ON A SLOPE EXCEEDING THE MAXIMUM GRADE. 60. NEVER OPERATE THE MACHINE ON A SLOPE EXCEEDING THE MAXIMUM GRADE. 61. NEVER OPERATE THE MACHINE ON A SLOPE EXCEEDING THE MAXIMUM GRADE. 62. NEVER OPERATE THE MACHINE ON A SLOPE EXCEEDING THE MAXIMUM GRADE. 63. NEVER OPERATE THE MACHINE ON A SLOPE EXCEEDING THE MAXIMUM GRADE. 64. NEVER OPERATE THE MACHINE ON A SLOPE EXCEEDING THE MAXIMUM GRADE. 65. NEVER OPERATE THE MACHINE ON A SLOPE EXCEEDING THE MAXIMUM GRADE. 66. NEVER OPERATE THE MACHINE ON A SLOPE EXCEEDING THE MAXIMUM GRADE. 67. NEVER OPERATE THE MACHINE ON A SLOPE EXCEEDING THE MAXIMUM GRADE. 68. NEVER OPERATE THE MACHINE ON A SLOPE EXCEEDING THE MAXIMUM GRADE. 69. NEVER OPERATE THE MACHINE ON A SLOPE EXCEEDING THE MAXIMUM GRADE. 70. NEVER OPERATE THE MACHINE ON A SLOPE EXCEEDING THE MAXIMUM GRADE. 71. NEVER OPERATE THE MACHINE ON A SLOPE EXCEEDING THE MAXIMUM GRADE. 72. NEVER OPERATE THE MACHINE ON A SLOPE EXCEEDING THE MAXIMUM GRADE. 73. NEVER OPERATE THE MACHINE ON A SLOPE EXCEEDING THE MAXIMUM GRADE. 74. NEVER OPERATE THE MACHINE ON A SLOPE EXCEEDING THE MAXIMUM GRADE. 75. NEVER OPERATE THE MACHINE ON A SLOPE EXCEEDING THE MAXIMUM GRADE. 76. NEVER OPERATE THE MACHINE ON A SLOPE EXCEEDING THE MAXIMUM GRADE. 77. NEVER OPERATE THE MACHINE ON A SLOPE EXCEEDING THE MAXIMUM GRADE. 78. NEVER OPERATE THE MACHINE ON A SLOPE EXCEEDING THE MAXIMUM GRADE. 79. NEVER OPERATE THE MACHINE ON A SLOPE EXCEEDING THE MAXIMUM GRADE. 80. NEVER OPERATE THE MACHINE ON A SLOPE EXCEEDING THE MAXIMUM GRADE. 81. NEVER OPERATE THE MACHINE ON A SLOPE EXCEEDING THE MAXIMUM GRADE. 82. NEVER OPERATE THE MACHINE ON A SLOPE EXCEEDING THE MAXIMUM GRADE. 83. NEVER OPERATE THE MACHINE ON A SLOPE EXCEEDING THE MAXIMUM GRADE. 84. NEVER OPERATE THE MACHINE ON A SLOPE EXCEEDING THE MAXIMUM GRADE. 85. NEVER OPERATE THE MACHINE ON A SLOPE EXCEEDING THE MAXIMUM GRADE. 86. NEVER OPERATE THE MACHINE ON A SLOPE EXCEEDING THE MAXIMUM GRADE. 87. NEVER OPERATE THE MACHINE ON A SLOPE EXCEEDING THE MAXIMUM GRADE. 88. NEVER OPERATE THE MACHINE ON A SLOPE EXCEEDING THE MAXIMUM GRADE. 89. NEVER OPERATE THE MACHINE ON A SLOPE EXCEEDING THE MAXIMUM GRADE. 90. NEVER OPERATE THE MACHINE ON A SLOPE EXCEEDING THE MAXIMUM GRADE. 91. NEVER OPERATE THE MACHINE ON A SLOPE EXCEEDING THE MAXIMUM GRADE. 92. NEVER OPERATE THE MACHINE ON A SLOPE EXCEEDING THE MAXIMUM GRADE. 93. NEVER OPERATE THE MACHINE ON A SLOPE EXCEEDING THE MAXIMUM GRADE. 94. NEVER OPERATE THE MACHINE ON A SLOPE EXCEEDING THE MAXIMUM GRADE. 95. NEVER OPERATE THE MACHINE ON A SLOPE EXCEEDING THE MAXIMUM GRADE. 96. NEVER OPERATE THE MACHINE ON A SLOPE EXCEEDING THE MAXIMUM GRADE. 97. NEVER OPERATE THE MACHINE ON A SLOPE EXCEEDING THE MAXIMUM GRADE. 98. NEVER OPERATE THE MACHINE ON A SLOPE EXCEEDING THE MAXIMUM GRADE. 99. NEVER OPERATE THE MACHINE ON A SLOPE EXCEEDING THE MAXIMUM GRADE. 100. NEVER OPERATE THE MACHINE ON A SLOPE EXCEEDING THE MAXIMUM GRADE.

# 6" TD-PLUS / CENTURY II

## MAIN AUGER COMPONENTS

### ENCLOSED HEAD DRIVE

**STANDARD  
DRIVE  
COMPLETE PART NO.  
1006251**

**RATIO 1 TO 1.27**

<b>REF. NO.</b>	<b>DESCRIPTION</b>	<b>PART NO.</b>
1	Aluminum Casting	638080-1
2	Aluminum Casting - Cover	638081-1
3	#60 Roller Chain - 32 pitch	1006250
4	Gasket	638088
5	3/8" Plug - Vented	1001438
6	1" Bearing Cone (Timken No. 07100)	835174
7	Key, 1/4" x 1 1/2"	*8371C
8	1" Bore Sprocket - 15 tooth	635049-1
8	1" Bore Sprocket - 19 tooth	N/A
9	Stub Shaft 1" x 8 1/4"	1005165
10	Stub Shaft 1" x 6 1/8"	553628
11	1" Bore Sprocket - 19 tooth	835176-1
11	1" Bore Sprocket - 15 tooth	N/A
12	5/16" x 1" HHCS	33046
13	5/16" Lockwasher	33144
14	3/8" x 2 1/2" Roll Pin	33203
15	Shaft Seal - 1"	835169
16	Coupler, 4" long	*1002382
17	Key, 1/4" x 1"	4020A1
18	Drain Plug - 1/4"	020009
19	1" Bearing Cup (Timken No. 07204)	835175
20	Self-Tapping Screw	*33183
21	1" Bearing Spacer	4542
22	Drive Shaft Cover Clip	*553630
--	Decal - Notice Oil Level	1005136

\*These items are NOT part of the complete assembly. They are sold separately.

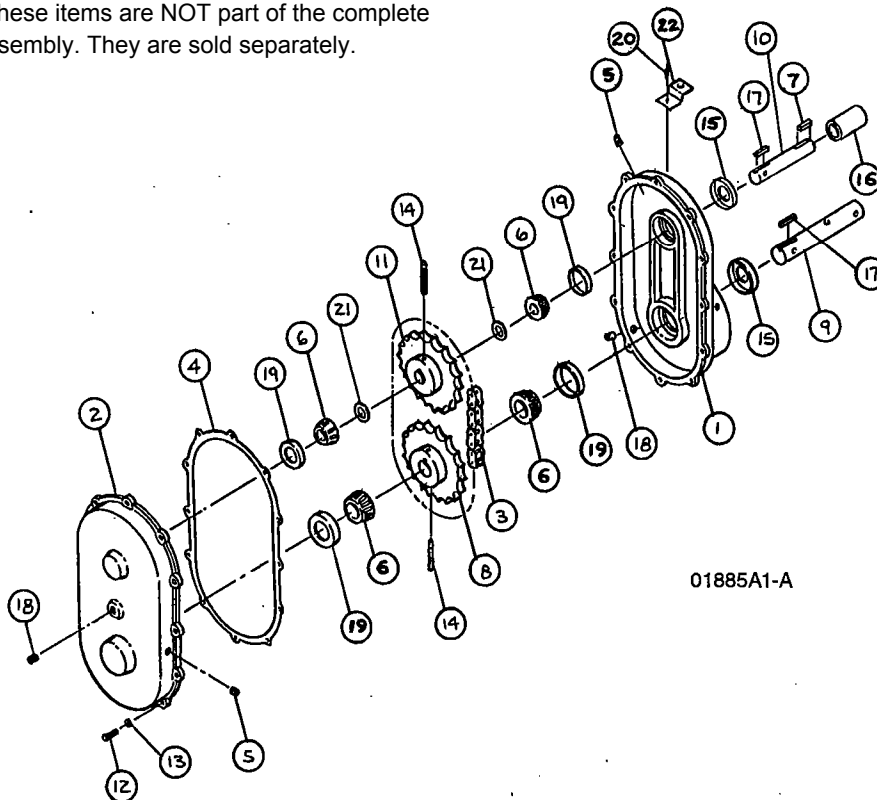

01885A1-A

# 6" TD-PLUS / CENTURY II

Page P-4

## MAIN AUGER COMPONENTS

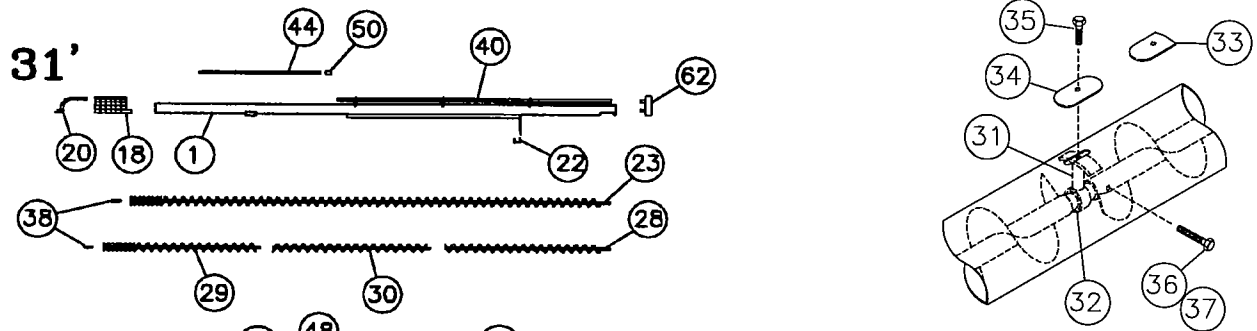

02872A1-A

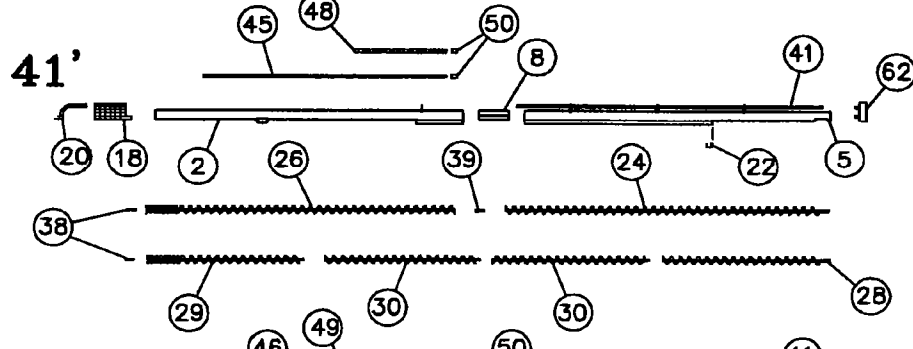

02908A2

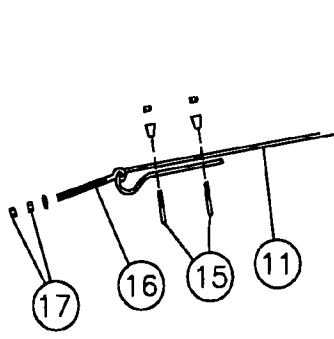
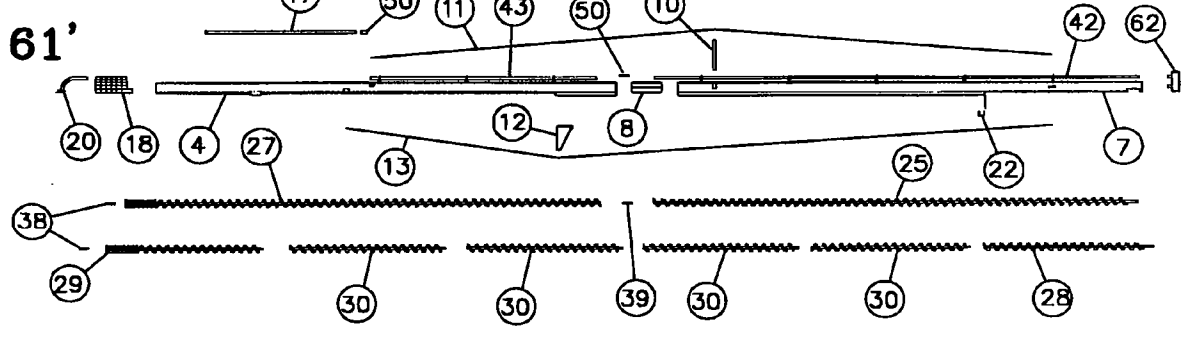
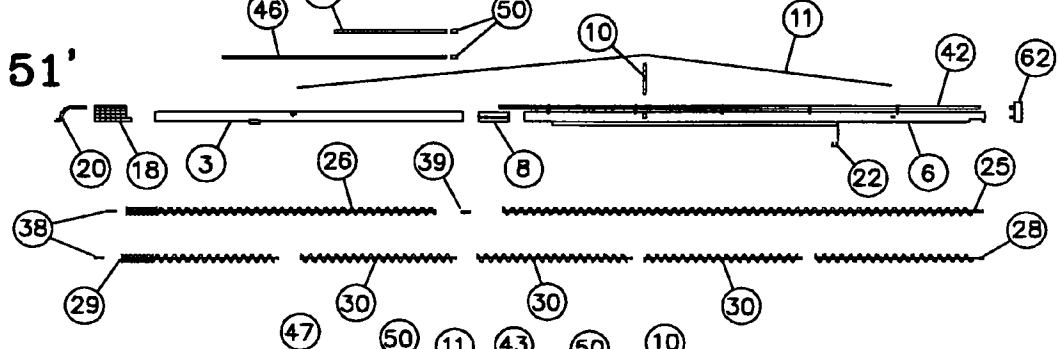

02881A1-A

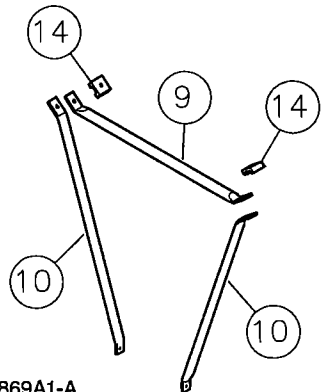

02869A1-A

## MAIN AUGER COMPONENTS

**NOTE:** Auger housings shown with drive shaft Attached are supplied with the specified drive shaft and drive shaft bearings.

### AUGER HOUSINGS

Ref. No.	Part No.	Description
1	1005269-230	Tube Section, 31' Models (Hutchinson)
(1)	1005269-330	Tube Section, 31' Models (Mayrath)
2	1010184-130	Tube Section, Lower, 41' Models
3	1010642-130	Tube Section, Lower, 51' Models
4	1010525-130	Tube Section, Lower, 61' Models
5	1010183-230	Tube Section, Upper, 41' Models (Hutchinson)
(5)	1010183-330	Tube Section, Upper, 41' Models (Mayrath)
6	1010641-230	Tube Section, Upper, 51' Models (Hutchinson)
(6)	1010641-330	Tube Section, Upper, 51' Models (Mayrath)
7	1010524-230	Tube Section, Upper, 61' Models (Hutchinson)
(7)	1010524-330	Tube Section, Upper, 61' Models (Mayrath)

### AUGER HOUSINGS f/ INTERNAL BEARINGS

Ref. No.	Part No.	Description
1	1014887-230	Tube Section, 31' Models (Hutchinson)
(1)	1014887-330	Tube Section, 31' Models (Mayrath)
2	1014829-130	Tube Section, Lower, 41' Models
3	1012991-130	Tube Section, Lower, 51' Models
4	1010486-130	Tube Section, Lower, 61' Models
5	1014828-230	Tube Section, Upper, 41' Models (Hutchinson)
(5)	1014828-330	Tube Section, Upper, 41' Models (Mayrath)
6	1012990-230	Tube Section, Upper, 51' Models (Hutchinson)
(6)	1012990-330	Tube Section, Upper, 51' Models (Mayrath)
7	1010487-230	Tube Section, Upper, 61' Models (Hutchinson)
(7)	1010487-330	Tube Section, Upper, 61' Models (Mayrath)

### TRUSS COMPONENTS

Ref. No.	Part No.	Description
9	550208	Top Truss Tube f/ 41' - 51'
(9)	1005358	Top Truss Tube f/ 61'
10	550209	Side Truss Tube f/ 41' - 51'
(10)	1005359	Side Truss Tube f/ 61'
11	63730	Top Truss Cable f/ 41' (1/4" x 21' long)
(11)	1002571	Top Truss Cable f/ 51' (1/4" x 34' long)
(11)	1002057	Top Truss Cable f/ 61' (1/4" x 41'-6" long)
12	1005357	Undertruss Stand-Off
13	1006206	Undertruss Cable, 1/4" x 43'
14	550313	Cable Clip
15	6369C	Cable Clamp
16	6308C	Eyebolt, 1/2" x 8" Gr. 2
17	D1169	Nut, 1/2" Nylon Lock

### MISCELLANEOUS COMPONENTS

Ref. No.	Part No.	Description
8	6309A	Connecting Band
18	1006189	Intake Guard
19	5046A1	Half-Band f/ Intake Guard (4")
20	1006165	Hitch Pipe
21	1022344	Bronze Bushing f/ Intake Guard
22	1005228	Stop f/ Undercarriage Track

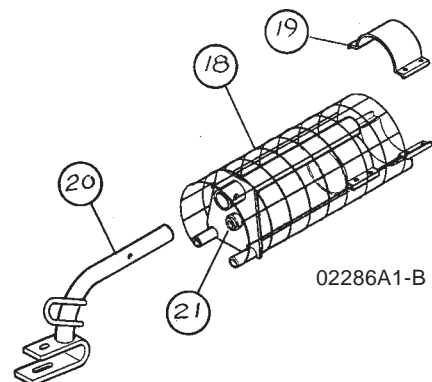

# 6" TD-PLUS / CENTURY II

Page P-6

## MAIN AUGER COMPONENTS

### FLIGHT SECTIONS

REF. NO.	PART NO.	DESCRIPTION
23	1015728P	Flight f/ 31' (31' lg) 7 ga.
24	1010185P	Flight, Upper f/ 41' (21' lg) 7 ga.
25	1005202-7GAP	Flight, Upper f/ 51' & 61' (31' lg) 7 ga.
26	1010186P	Flight, Lower f/ 41' & 51' (20' lg) 7 ga.
27	1010526P	Flight, Lower f/ 61' (31' lg) 7 ga.

### FLIGHT SECTIONS FOR INTERNAL BEARING UNITS 7 GA. THICK ON 1.9 O.D. CENTER SHAFT

REF. NO.	PART NO.	DESCRIPTION
28	1012874 P	Flight Upper
29	1012881 P	Flight Lower
30	1012880 P	Flight Intermediate

### OPTIONAL INTERNAL BEARING FLIGHT COMPONENTS

REF. NO.	PART NO.	DESCRIPTION
31	60521	Bearing Hanger w/1" I.D. Bronze Bushing
32	6303D	Replacement Bronze Bushing only
33	1013225	Bearing Mounting Plate, 4 3/8" long
34	1012079	Bearing Mounting Plate, 7 1/4" long
35	33276	5/8" x 1 1/2" Hex Head Capscrew, Gr. 5
36	33375	3/8" x 2 1/2" lg. Hex Head Capscrew, Gr. 8
37	1011738	3/8" Stover Type Locknut
38	6392D	Bolt-in Intake Stub (1" x 6 1/4")
--	1012878	Weld-in Connecting Stub
--	50190	Repair Flight per foot (7 ga.)

### STANDARD FLIGHT COMPONENTS

REF. NO.	PART NO.	DESCRIPTION
38	6392D	Bolt-in Intake Stub (1" x 6 1/4")
39	6389D	Connecting Stub (1" x 7")

### DRIVE SHAFT COMPONENTS

REF. NO.	PART NO.	DESCRIPTION
40	1005320	Drive Shaft, 1" x 215" lg. (f/31')
41	1002456	Drive Shaft, 1" x 240" lg. (f/41')
42	1002457	Drive Shaft, 1" x 375 1/2" lg. (f/51' & 61' Upper)
43	1005243	Drive Shaft, 1" x 177" lg. (f/61' Lower)
44	1005523	Drive Shaft, 1" x 93 1/2" lg. (f/31' w/PTO Drive)
45	1005360	Drive Shaft, 1" x 189 1/2" lg. (f/41' w/PTO Drive)
46	1005322	Drive Shaft, 1" x 174" lg. (f/51' w/PTO Drive)
47	1006240	Drive Shaft 1" x 117" lg. (f/61' w/PTO Drive)
48	1003381	Drive Shaft 1" x 72" lg. (f/41' w/Electric Drive)
49	1005044	Drive Shaft, 1" x 87 1/2" lg. (f/51' w/Electric Drive)
50	1002382 P	Drive Shaft Coupler w/Snap Ring
51	1002381	Snap Ring Only
52	8371C	Square Key, 1/4" x 1 1/2" long
53	---	Drive Shaft Cover
	550651	5'-8 1/4" lg.
	550650	5'-0" lg.
	550649	4'-0" lg.
	550648	3'-0" lg.
	550647	2'-0" lg.
	550645	1'-0" lg.
	550644	8" lg.
54	---	Telescoping Drive Shaft Cover, 1'-6" lg.
	550646	8" lg. (f/51' PTO Model only)
	550643	8" lg. (f/51' PTO Model only)
55	33183	Sheet Metal Screw
56	33020	Washer 1" O.D. x 1/4" I.D.
57	1002603	Drive Shaft Cover Bracket
58	1005210	Band-on Bearing Stand
59	5048A1	Half band for Band-on Brg. Std.
60	6382C	Bearing 1" w/Collar
61	6383C	Bearing Flangette
62	1006251	Head Drive Assembly (See page P-3 for head assembly components)
63	---	See Drive Components, (Pages P-10 to P-14)

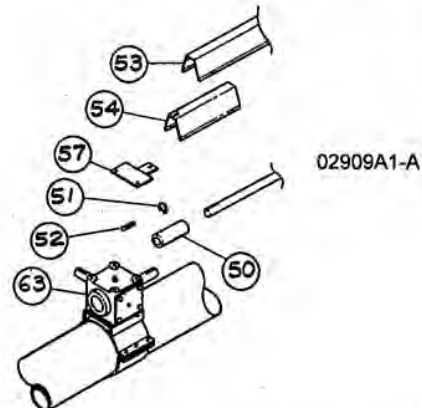
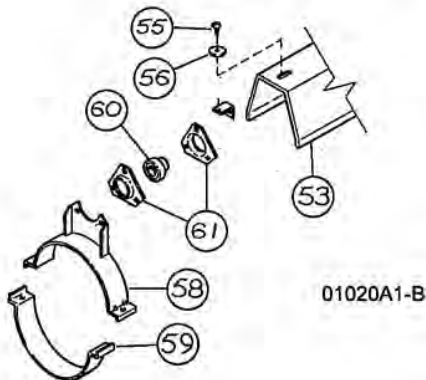

UNDERCARRIAGE COMPONENTS

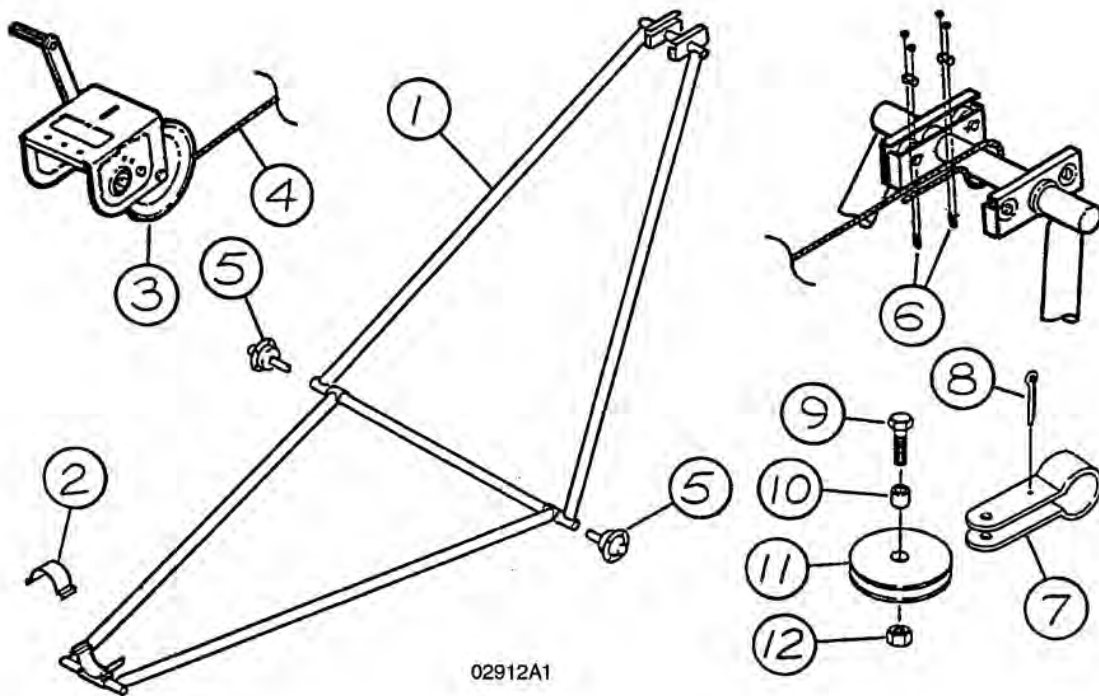

REF. NO.	PART NO.	DESCRIPTION
1	---	Undercarriage (Complete with Slide Assembly)
	1005174	f/31'
	1005175	f/41'
	1005176	f/51'
	1005177	f/61'
2	5046A1	Halfband, 4" wide
3	---	Winch (See page P-8 for parts breakdown.)
	3339A11	f/31' thru 51'
	3335A11	f/61'
4	---	Winch Cable
	6373D	f/31' (1/4" x 21' long)
	1003819	f/41' (1/4" x 28' long)
	8382C	f/51' (1/4" x 54' long)
	551349	f/61' (1/4" x 70' long)
5	---	See page P-9 for spindle and hub components
6	6369C	Cable Clamp, 1/4"
7	5120A1	Pulley Clevis
8	D1263	Cotter Pin, 1/4" x 2" long
9	1002228	1/2" x 2" Hex Head Capscrew, Grade 5
10	50079A1	Pulley Bushing
11	3223A1	1/4" Cable Pulley
12	33138	1/2" Nylon Locknut
13	1006197	Pulley & Clevis Assembly (includes Ref. 7 thru 12)
--	6393D	15" x 4.5 KB 4-Bolt Wheel

# 6" TD-PLUS / CENTURY II

## UNDERCARRIAGE COMPONENTS

### WINCH - BRAKE TYPE

#### COMPLETE WINCH - PART NUMBER 3339A11

#### FULTON MODEL K-1051 WINCH

USED ON 6" x 31', 41' & 51' AUGERS

REF. NO.	DESCRIPTION	QTY. REQ.	HUTCHINSON/	
			MAYRATH PART NO.	FULTON PART NO.
1	11" Handle Assy.	1	41595	2461-01
2-5	Rope Keeper Kit	1	41600	5621S01
6-10	Ratchet Kit	1	40840	6731S00
* 11	Locknut - Hex, 3/8-16	1	33234	907-01
* 12	Locknut - Hex, 1/2-13	3	33138	952-01
13	Brake Disc	1	41906	2552-01
14	Ratchet Assembly	1	41908	2555-01
15	Pinion Gear Assembly	1	1003595	0434003-01
16	Friction Disc	1	41909	2356-00
17	Spacer Drum	1	41910	6284-05
18	Capscrew Hex - 3/8 - 16	1	41911	6299-01
19	Drum Assembly	1	41912	9186-01
20	K-1051 Frame Assembly	1	N/A	N/A
21	Bushing 1.25 ID x .50	1	41914	4592-19
22	Bushing .75 ID x .50	1	41915	5790-19
23	Pinion Shaft	1	1003589	0469001-01
25	Washer - Thrust	1	1003590	178-00
26	Retaining Ring	1	1003591	57-01

NOTE: Repair parts for this winch can also be purchased directly from:  
**Fulton Manufacturing Corp.**  
 P.O. Box 19903  
 Milwaukee, WI 53219

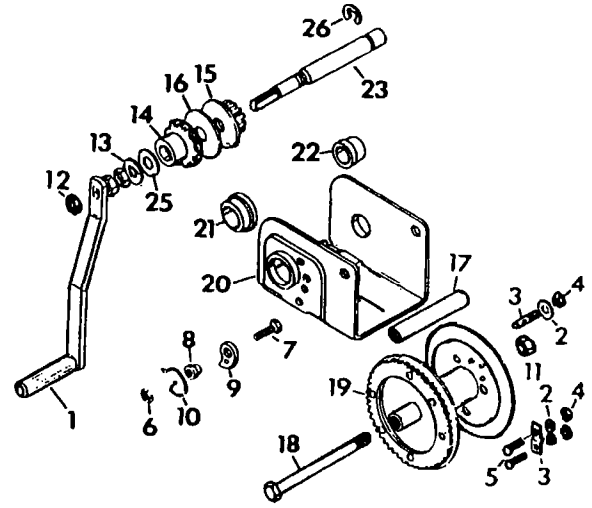

01956A1

### WINCH - BRAKE TYPE

#### COMPLETE WINCH - PART NUMBER 3335A11

#### FULTON MODEL K-1550 WINCH

USED ON 6" x 61' AUGERS

NOTE: Repair parts for this winch can also be purchased directly from:  
**Fulton Manufacturing Corp.**  
 P.O. Box 19903  
 Milwaukee, WI 53219

REF. NO.	DESCRIPTION	HUTCHINSON/ MAYRATH PART NO.	FULTON PART NO.
1	Handle Assembly	41595	2461S01
2	Cable Clamp		
3	Lock Washer & Nut	Cable Keeper Kit 41600	Cable Keeper Kit 5621S01
4	Carriage Bolt		
5	Lock Nut 5/16" - 18 Hex		
6	Ratchet Spacer	Ratchet Kit 40836	Ratchet Kit 6730S00
7	Ratchet Spring		
8	Ratchet Paul		
9	Hex Head Shoulder Bolt 5/16" - 18		
10	Brake Disc Kit	41596	1558S00
11	Input Shaft		
12	Lock Nut 1/2" - 13 Hex		
13	Spacer	Input Shaft Kit	Input Shaft Kit
14	Bushing		
15	Shaft Brake Disc	41597	1563S01
16	Ratchet Gear		
17	Pinion & Disc Assembly		
18	Hex Lock Nut 1/2" - 13	*	*
19	Drum Assembly	**	**
20	Frame	**	**
21	Hex Head Capscrew 1/2" - 13-5 3/4"	*	*
22	Drum Spacer	**	**
23	Hex Head Capscrew 3/8" - 16-5 3/4"	*	*
24	Frame Spacer	**	**
25	Hex Lock Nut 3/8" - 18	*	*
26	Handle Label	2169A1	**

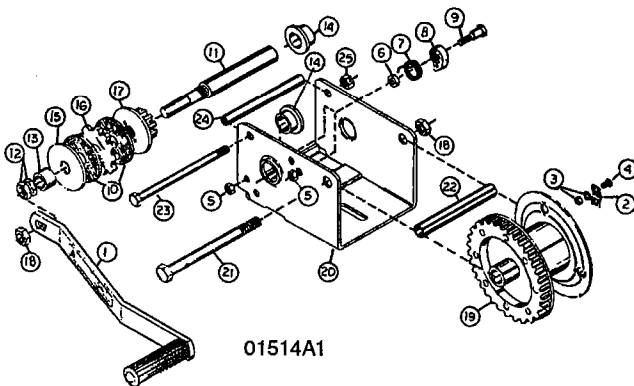

01514A1

\*Indicates standard hardware items - purchase locally.

\*\*These items are not available as separate parts because of the precision assembly required. If these parts require replacement, a new winch unit is recommended.

# 6" TD-PLUS / CENTURY II

## UNDERCARRIAGE COMPONENTS

### SPINDLE & HUB ASSEMBLY

REF. NO.	DESCRIPTION	HUTCHINSON/ MAYRATH	TIMKEN
		PART NO.	PART NO.
--	Spindle & Hub Assembly	1011562	---
1	Spindle, 1 5/8" x 10"	1001001	---
2	Grease Seal	106245	---
3	Inner Cone	3079R1	LM67048
4	Inner Cup	3148R1	LM67010
5	Hub, 4-Bolt	90174	---
6	Outer Cup	40552	LM11910
7	Outer Cone	40551	LM11949
8	Lug Bolt	106241	---
9	Washer	106252	---
10	Slotted Hex Nut, 5/8"	106250	---
11	Cotter Pin, 5/32" x 1 1/4"	D1146	---
12	Hub Cap	106244	---

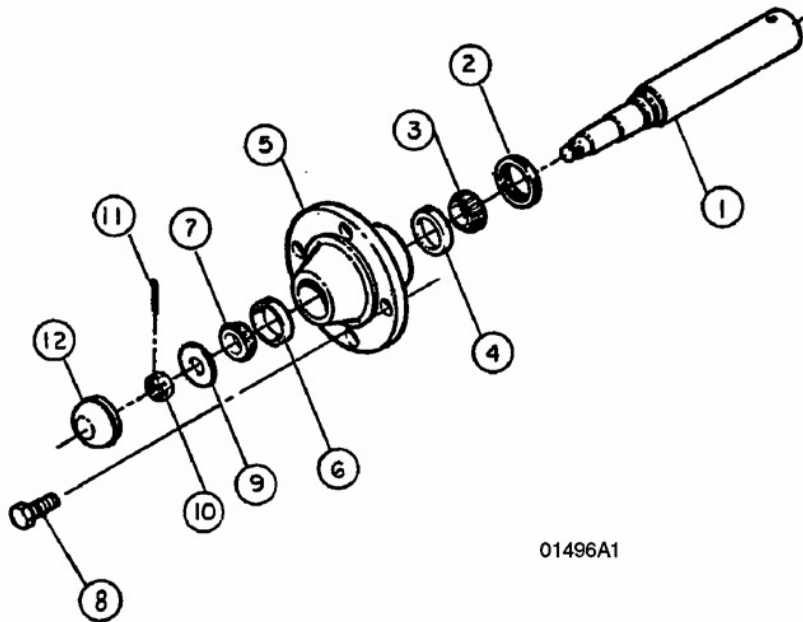

01496A1

# 6" TD-PLUS / CENTURY II

## PTO DRIVE COMPONENTS

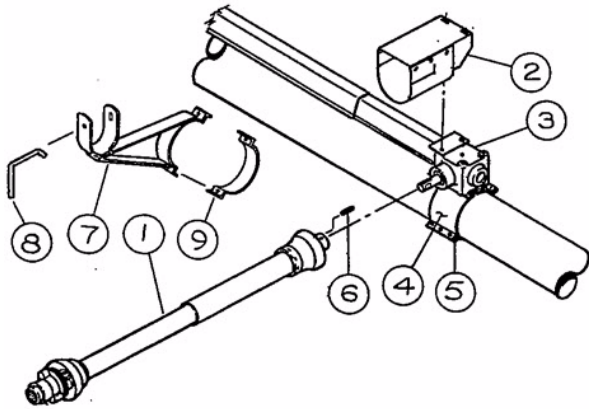

01927A1-B

REF. NO.	PART NO.	DESCRIPTION
1	1002171	PTO Driveline (See below for parts breakdown.)
2	862113	PTO to Gearbox Shield
3	1001592-2	Gearbox (See page P-12 for parts breakdown.)
4	6024A1	Gearbox Mount
5	5028A1	Halfband, 6" wide
6	8371C	Square Key 1/4" x 1 1/2" long
7	6833A1	PTO Driveline Support
8	3338A1	Driveline Support Pin
9	5048A1	Halfband

## PTO DRIVELINE COMPONENTS

**PIN STOP STYLE DRIVELINE  
U-JOINT TYPE - 12R  
AUGER END 1" BORE WITH 1/4" KEYSEAT  
TRACTOR END 1 3/8" - 6B SPLINE W/SHEAR BOLT**

**NOTE: Repair parts for this driveline can also be purchased directly from:  
Weasler Engineering, Inc.  
P.O. Box 558  
West Bend, WI 53095**

REF NO.	DESCRIPTION	HUTCHINSON/ MAYRATH PART NO.	WEASLER PART NO.
--	PTO Driveline Complete	1002171	222-15986
1	Joint & Tube Half Assembly with Guard (Auger End)	1015283	92-15986
2	Roll Pin 1/4" x 1" long	1003691	11-10454
3	Inner Safety Sign	13-10022	13-10022
4	Shield Nylon Bearing Kit	1006753	19-11110
5	Inner Guard (Includes Ref. No. 4.)	1006483	96-15986
6	12R U-Joint Cross Repair Kit	40515	03-10077
7	End Yoke	1003664	12021-1082
8	.375 - 16 x .38 long Setscrew	33170	N/A
9	Joint & Shaft Half Assembly with Guard (Tractor End)	1015284	93-15986
10	Spring Lock Flange Repair Kit	1003674	26-10133
11	Shear Bolt & Nut Kit (See note)	1004778	N/A
12	Yoke & Ball Shear Assembly	1006485	26-11671
13	Outer Guard (Includes Ref. No. 4)	1006486	97-15986
14	Outer Safety Sign	13-10021	13-10021

**NOTE: Shear Bolt Kit Includes (6) 5/16" - 18 x 1" long Grade 5 hex head bolts and locknuts.**

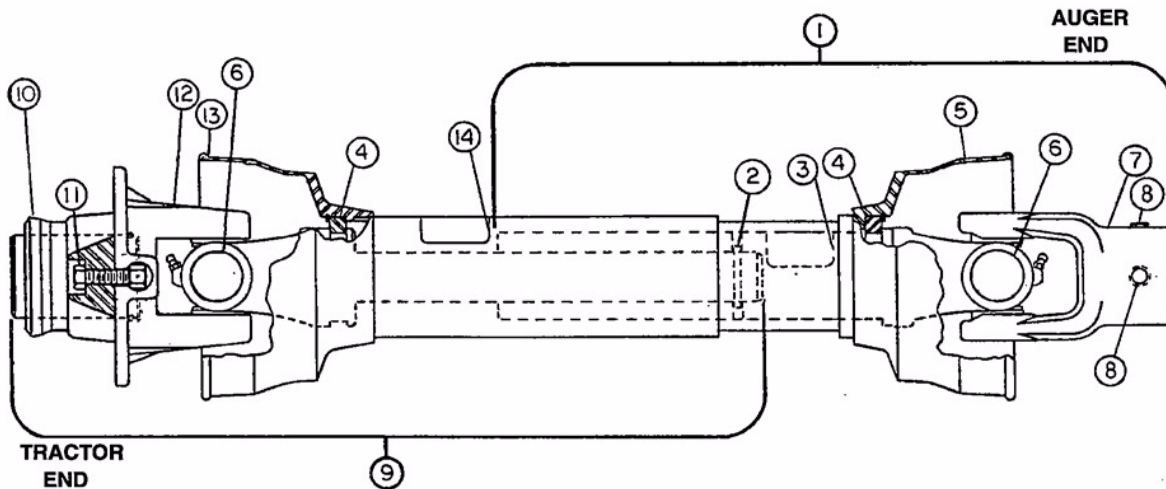

**ELECTRIC DRIVE  
COMPONENTS**

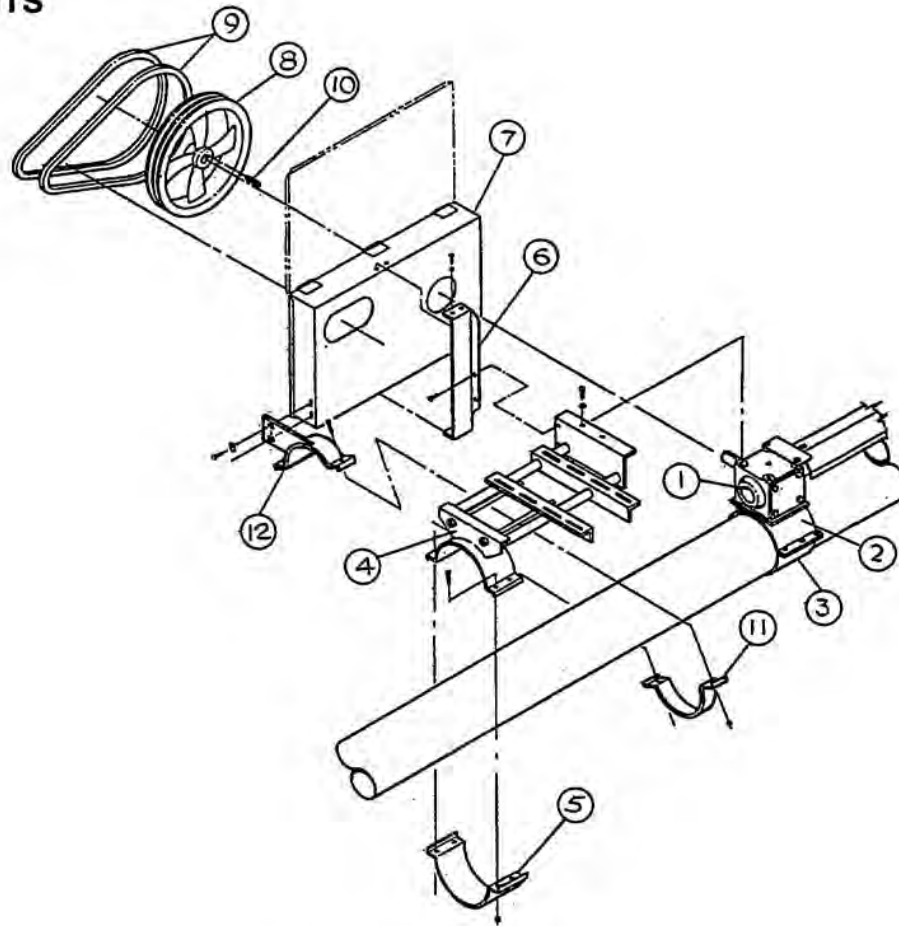

REF NO.	PART NO.	DESCRIPTION
1	1001592-2	Gearbox A115 (1 to 1 Ratio) (See Page P-12 for parts breakdown)
2	6024A1	Gearbox Mount
3	5028A1	Half Band for Gearbox
4	1005289	Motor Mount Frame
5	5046A1	Half Band for Motor Mount Frame
6	1002760	Belt Guard Mount Bracket
7	1002747	Belt Guard
8	40149	Aluminum Sheave 1B 12" - 1" Bore f/31'
8	40151	Aluminum Sheave 2B 12" - 1" Bore f/41', 51' & 61'
9	40120	Belt B-57
10	8371C	Square Key 1/4" x 1 1/2" f/31'
10	4045A1	Square Key 1/4" x 2" f/41', 51' & 61'
11	5048A1	Half Band 2" wide
12	1005292	Belt Guard Mounting Band

# 6" TD-PLUS / CENTURY II

## GEARBOX

(Complete Gearbox Part No. 1001592-2)

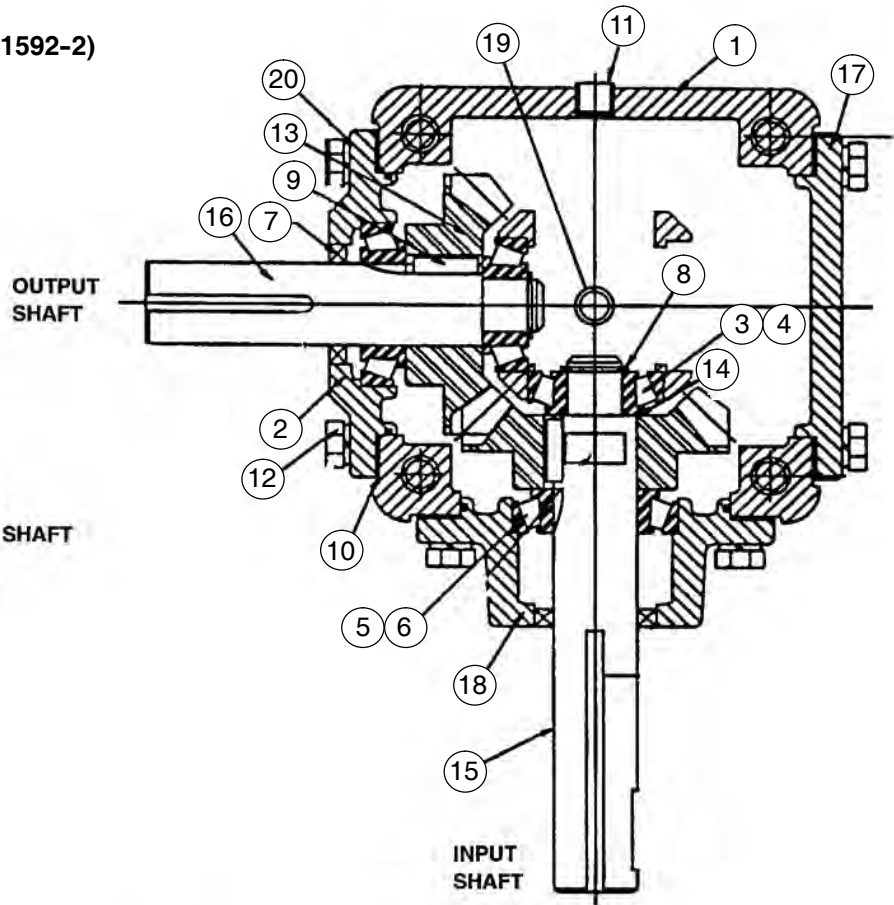

USED ON 6" x 31', 41', 51' & 61'  
 ELECTRIC DRIVE AND PTO DRIVE  
 1" DIA. INPUT SHAFT - 1" DIA. OUTPUT SHAFT  
 3/8" MOUNTING HOLES  
 4 1/4" SQUARE MOUNTING PATTERN  
 RATIO: 1 TO 1

REF. NO.	QTY. REQ'D.	PART. NO.	DESCRIPTION
1	1	70-06072	Case
2	1	70-16041	Machined End Cap
3	1	12-20107	Bearing Cone
4	1	12-20106	Bearing Cup
5	3	12-20105	BearingCone
6	3	12-20104	Bearing Cup
7	2	28-11002	Seal
8	1	24-15249	Snap Ring
9	2	11-61015	Key, 1/4" sq. x 15/16" long
10	-	19-15201	Shim Kit
11	3	11-81029	1/4"-18 NPT Pipe Plug
12	12	11-20439	5/16" x 3/4" NC Capscrew
13	2	71-06047	Gear 90° Bevel - 19 Tooth
14	1	11-40604	Spacer
15	1	09-70103	Input Shaft
16	1	09-70102	Cross Shaft
17	1	70-16039	Machined End Cap
18	1	70-26044	Machined Bearing Housing
19	1	11-81026	1/4" Vented Plug
20	3	28-21000	O-Ring
-	-	18-15203	Gasket Kit

The Part Number's Shown are Weasler Part Number's.  
 Parts can be purchased directly from:  
**Weasler Engineering Inc.**  
**P.O. Box 558**  
**West Bend, WI 53095**  
**Tel: +1-262-338-2161**  
**Fax: + 1-262-338-3709**

# 6" TD-PLUS / CENTURY II

## UNDERSLUNG DRIVE COMPONENTS

USED ON 31' and 41' ONLY

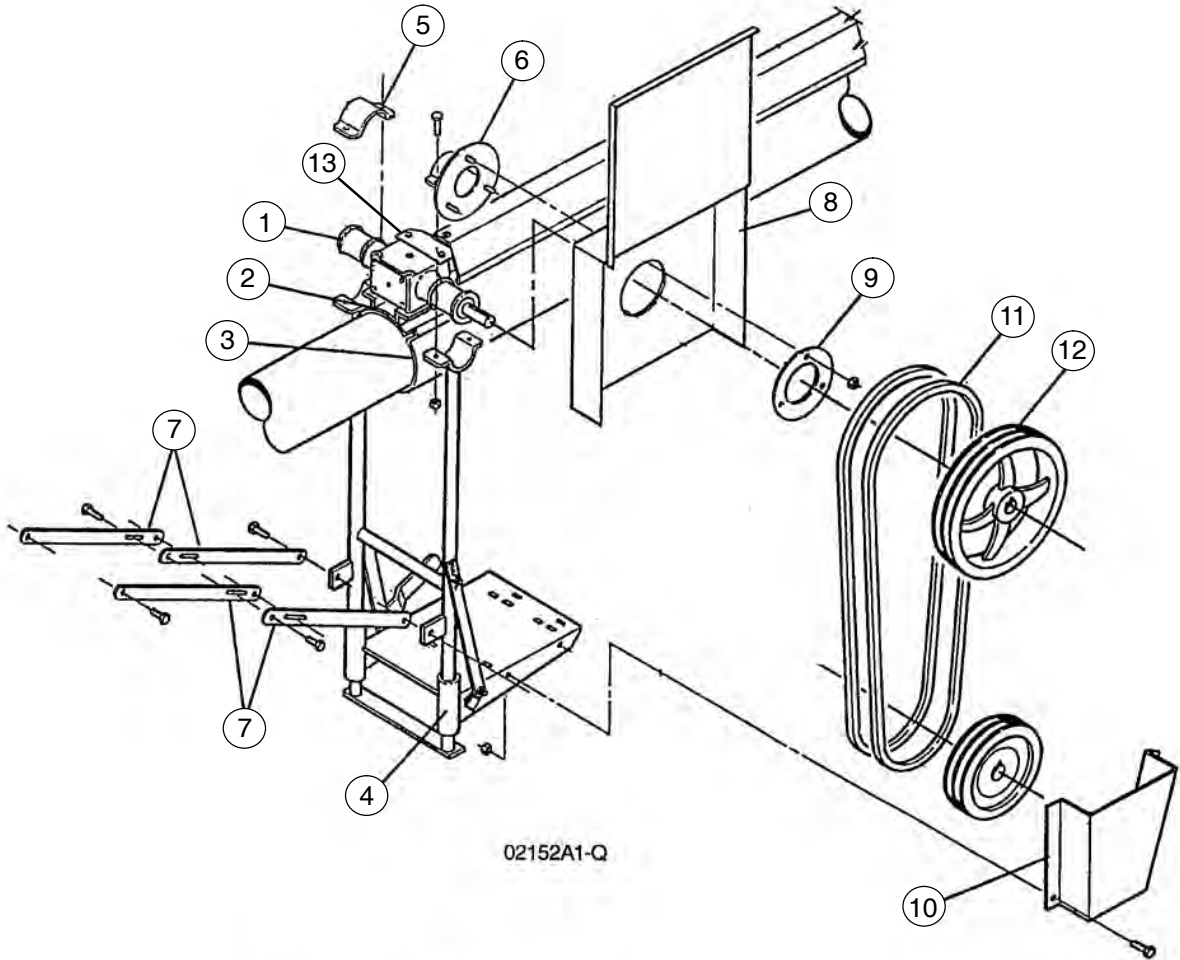

02152A1-Q

REF. NO.	PART. NO.	DESCRIPTION
1	1029210-1	Gearbox w/ Pivot Ears (A115) (1 1/2 to 1 Ratio)
2	1031446	Band-On Gearbox Mount
3	5048A1	Half-Band (2" wide)
4	1031447	Underslung Frame
5	1031436	Pivot Clamp
6	1031480	Pivot Clamp w/ Belt Guard Bracket
7	1005525	Adjustment Strap
8	1005023	Large Belt Guard
9	1005051	Belt Guard Ring
10	1005126	Small Belt Guard
11	1016292	B-93 Belt
12	40152	Sheave, 12" 2B 1.25" Bore
13	1031481	Drive Shaft Cover Bracket

# 6" TD-PLUS / CENTURY II

Page P-14

## GEARBOX

Complete Gearbox Part No. 1029210-1

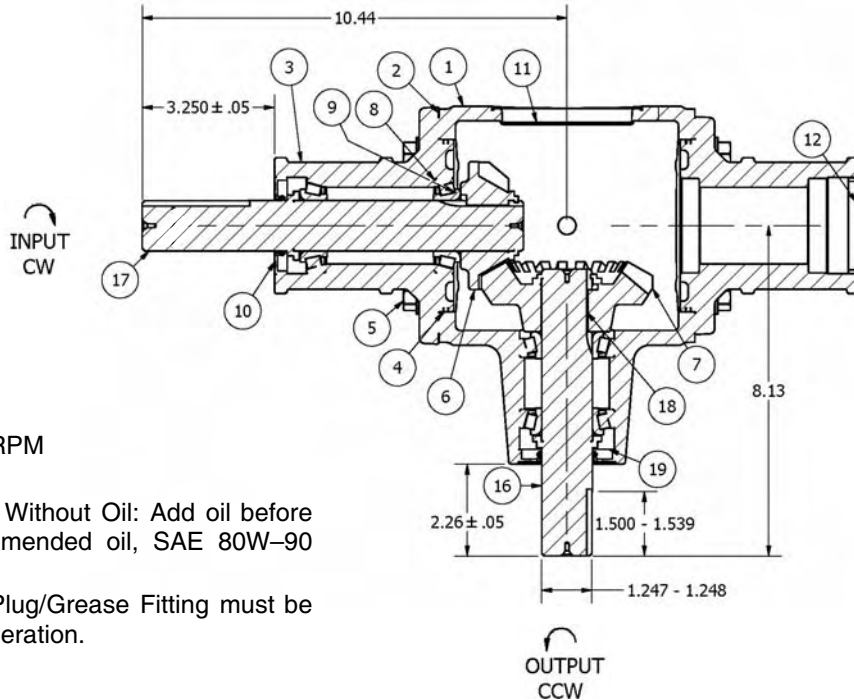

Input Speed 540 RPM

Ratio 1.5:1

Gearbox Shipped Without Oil: Add oil before operation. Recommended oil, SAE 80W-90 Approx. 36.9 oz.

Vent Plug/Relief Plug/Grease Fitting must be installed before operation.

The Part Number's Shown are Weasler Part Number's.

Parts can be purchased directly from:

**Weasler Engineering Inc.**  
**P.O. Box 558**  
**West Bend, WI 53095**  
**Tel: +1-262-338-2161**  
**Fax: + 1-262-338-3709**

REF. NO.	QTY. REQ'D.	PART. NO.	DESCRIPTION
1	1	70-06128	Machined Housing
2	1	19-15204	Gasket Kit
3	2	70-26051	Machined Bearing Housing
4	2	28-21003	O-Ring
5	8	11-20442	Screw, 3/8-16 x 1" gr 5
6	1	71-06095	Gear, 14 Teeth/M=5.25
7	1	71-06096	Gear, 21 Teeth/M= 5.25
8	4	12-20110	Bearing Cup
9	4	12-20111	Bearing Cone
10	2	28-11005	Seal
11	1	11-81037	Stamping Cover
12	1	28-11026	Seal
13	1	19-15207	Shim Kit
14	4	11-40541	Spacer
15	2	24-15250	Retaining Ring
16	1	09-70133	Shaft
17	1	09-70134	Shaft
18	2	11-61019	1/4" sq. x 1.1" Key
19	2	24-15251	Retaining Ring
—	2	11-81029	1/4-18 NPT Pipe Plug
—	1	11-81035	1/4 NPT Sq. Head Vent Plug





## ***Hutchinson/Mayrath***

*A Division of GLOBAL Industries Inc.*

Hutchinson/Mayrath • P.O. Box 629 • Clay Center, KS. 67432  
Ph. 785-632-2161 • Fx. 785-632-5964 • Toll Free 800-523-6993  
[www.hutchinson-mayrath.com](http://www.hutchinson-mayrath.com)