

12" x 31' TRUCK UNLOADING AUGER

OWNER'S & OPERATOR'S MANUAL

Effective July 22, 2002

Publication No. 1018715



Hutchinson/Mayrath/TerraTrack

A Division of GLOBAL Industries, Inc.

P.O. Box 629 • 514 W. Crawford • Clay Center, KS 67432
Phone 785-632-2161 • 1-800-523-6993 • FAX 785-632-5964



Hutchinson/Mayrath/TerraTrack

A Division of GLOBAL Industries, Inc.

POLICIES AND PROCEDURES

- PRICES:** Prices in effect at time of shipment will apply. Prices are subject to change without notice. All prices are F.O.B. Clay Center, Kansas. Orders shipped from locations other than Clay Center, Kansas will be subject to additional charges, such as back freight and/or additional freight.
- SERVICE CHARGE:** A service charge will be assessed on all past due balances as permitted by state law not to exceed 1-1/2% per month.
- MINIMUM ORDER:** Processing and handling costs necessitate a minimum charge of \$15.00 net on all orders.
- BACK ORDERS:** Back orders will be shipped as they become available. Contact Hutchinson/Mayrath/TerraTrack Customer Service for alternative shipping options or if cancellation is desired.
- DAMAGED GOODS:** It is the consignee's responsibility to check all shipments thoroughly upon receipt of goods. If any damage is discovered, it must be noted on the freight bill of lading before signing. The consignee must make necessary claims against the respective freight line. All damage claims must be submitted within 30 days of delivery receipt.
- SHORTAGES:** All shortages must be noted at time of delivery receipt. Shortages must be noted on the freight bill of lading before signing. Hutchinson/Mayrath/TerraTrack must be advised of all concealed shortages upon discovery. Once notified of concealed shortages Hutchinson/Mayrath/TerraTrack will advise corrective action to be taken.
- RETURN OF GOODS:** All returns must be approved by Hutchinson/Mayrath/TerraTrack prior to shipment. All return requests will be issued a return authorization number. **NO RETURNS WILL BE ACCEPTED WITHOUT A RETURN AUTHORIZATION NUMBER AND PRIOR AUTHORIZATION FROM THE FACTORY.** All returns must be shipped prepaid. A 15% restocking charge will be applied to all returned merchandise. Custom products may not be returned for credit. Only current products in new and saleable condition may be returned. No safety devices may be returned for credit.
- MODIFICATIONS:** It is the policy of Hutchinson/Mayrath/TerraTrack to improve its product whenever possible and practical to do so. We reserve the right to make changes, improvements and modifications at any time without incurring the obligation to make such changes, improvements and modifications on any equipment sold previously.
- LIMITED WARRANTY:**
- (a) For a period of (1) year after receipt of goods by the original consumer buyer, Hutchinson/Mayrath/TerraTrack will supply free of charge replacement parts for parts that prove defective in workmanship or material. Defective parts must be returned freights prepaid to a specified Hutchinson/Mayrath/TerraTrack location. Only Hutchinson/Mayrath/TerraTrack original repair parts may be used for warranty repairs.
 - (b) This limited warranty does not extend to parts designed to wear in normal operation and be replaced periodically, or to damage caused by negligence, accident, abuse or improper installation or operation.
 - (c) **GOODS NOT MANUFACTURED BY HUTCHINSON/MAYRATH/TERRATRACK CARRY ONLY THE MANUFACTURER'S WARRANTY.**
 - (d) **THIS UNDERTAKING IS IN LIEU OF ALL OTHER WARRANTIES, EXPRESSED OR IMPLIED, INCLUDING MERCHANTABILITY AND FITNESS FOR A PARTICULAR PURPOSE.**
- FAILURE TO FOLLOW THE INSTRUCTIONS CONTAINED IN THE OWNER'S & OPERATOR'S MANUALS AND THE ITEMS LISTED BELOW WILL RESULT IN THE VOIDING OF THIS LIMITED WARRANTY.**
- (1) Improper assembly, including failure to properly install all safety equipment.
 - (2) Improper installation (power & wiring included)
 - (3) Unauthorized alterations of goods.
 - (4) Goods operated when obviously in need of repair.
 - (5) Use of unauthorized repair parts.
 - (6) Irresponsible operation.
 - (7) Used to handle materials other than free flowing, non-abrasive and dry materials, as intended.
 - (8) Damaged through abusive use or accident.
- LIMITATION OF LIABILITY:** BUYER AGREES THAT IN NO EVENT SHALL HUTCHINSON/MAYRATH/TERRATRACK HAVE LIABILITY FOR DIRECT DAMAGES IN EXCESS OF THE CONTRACT PRICE OF THE GOODS IN RESPECT TO WHICH CLAIM IS MADE. BUYER FURTHER AGREES THAT IN NO EVENT SHALL HUTCHINSON/MAYRATH/TERRATRACK ON ANY CLAIM OF ANY KIND HAVE LIABILITY FOR LOSS OF USE, LOSS OF PROFITS, OR FOR ANY INDIRECT, INCIDENTAL OR CONSEQUENTIAL DAMAGES.

GENERAL SAFETY STATEMENT

This manual was written with the safety of the operator and others who work with the equipment as our prime concern. The instructions presented will help the reader learn SAFE day to day work practices. We want you as our partner in safety.

It is your responsibility as an owner, operator or supervisor to know what specific safety requirements and precautions exist and to make these known to all other personnel working with the equipment or in the area, so that they too may safely perform their duties and avoid any potentially hazardous situations.

Please remember safety equipment provides important protection for persons around a grain handling system that is in operation. Be sure that ALL safety shields and protection devices are installed and properly maintained. If any shields or guards are damaged or missing, contact your dealer to obtain the correct items.

Avoid any alterations of the equipment. Such alterations may create a dangerous situation where serious injury or death may occur.

SAFETY ALERT SYMBOL

The symbol shown below is used to call your attention to instructions concerning your personal safety. Watch this symbol - it points out important safety precautions. It means "ATTENTION! Become alert! Your personal safety is involved!" Read the message that follows and be alert to the possibility of personal injury or death.



BE ALERT! YOUR SAFETY IS INVOLVED.



WARNING

Anyone who will operate or work around this machine shall first read this manual! This manual must be delivered with the equipment to its owner. Failure to read this manual and its safety instructions is a misuse of the equipment.

TABLE OF CONTENTS

General Safety Statements	1
Safety Symbol	1
Operator Qualification	3
Sign Off Sheet	3
Machine Inspection	3
TRANSPORTING AUGER	4-5
Hitching to Towing Vehicle	4
Moving Auger	4-5
PLACEMENT OF AUGER	5-6
Step 1 - Locate the Auger	5
Step 2 - Place Auger Next to Bin	5
Step 3 - Raising the Auger	6
Winch Instructions	6
DESIGNATED WORK AREA	7
OPERATING PROCEDURES	8-11
Start Up & Break In	8
Recommended Auger Flight Speed	8
Electric Motor Drive	8
PTO Drive Information	9
Operating Capacities	10
Shut Down	10
Lockout	10
Relocation of Auger	11
LUBRICATION AND MAINTENANCE	11-13
Gearbox	11
PTO Driveline	12
Friction Type Winch	12
Undercarriage Axle Spindle Bearing	12
Head Bearing	12
Drive Shaft Bearing	12
Intake Guard Bearing	13
Head Drive Chain	13
TROUBLE SHOOTING	13
ASSEMBLY INSTRUCTIONS	14-22
PARTS LIST	P-1 thru P-8

SERIAL NUMBER

To ensure efficient and prompt service, please furnish us with the model and serial number of your auger in all correspondence or other contact. The serial plate is located on the winch mount on the lower section of auger housing.

RIGHT AND LEFT DESIGNATION

When determining which is the left or right hand side of the unit, it is as if a person were standing at the intake end and looking toward the discharge end.

OPERATOR QUALIFICATIONS

Operation of this portable auger shall be limited to competent and experienced persons. In addition, anyone who will operate or work around a portable auger must use good common sense. In order to be qualified, he must also know and meet all other requirements, such as:

1. Some regulations specify that no one under the age of 16 may operate power machinery. This includes portable augers. It is your responsibility to know what these regulations are in your own area or situation.
2. Current OSHA regulations state in part: "At the time of initial assignment and at least annually thereafter, the employer shall instruct every employee in the safe operation and servicing of all equipment with which the employee is, or will be involved."*
3. Unqualified persons are to stay out of the work area as shown in the work area diagrams. See Page 7.
4. A person who has not read and understood all operating and safety instruction is not qualified to operate the machine.

*Federal Occupational Safety & Health Standards for Agriculture Subpart D, Section 1928.57 (a)(6).

SIGN OFF SHEET

As a requirement of OSHA it is necessary for the employer to train the employee in the safe operation and safety procedures with this auger. We include this sign off sheet for your convenience and personal record keeping.

DATE	EMPLOYER SIGNATURE	EMPLOYEE SIGNATURE

MACHINE INSPECTION

After delivery of your new auger and/or completion of assembly and before each use, inspection of the machine is mandatory. Use the assembly instructions in this manual as a reference to determine that the auger is assembled properly. This inspection should include, but not be limited to:

1. Check to see that all guards listed in the assembly instructions are in place and secured and functional. Input driveline must rotate easily.
2. Check all safety signs and replace any that are worn, missing or illegible. The safety signs are listed on page P-1 and P-2. Safety signs may be obtained from your dealer or ordered from the factory.
3. Check winch and cable for security and operation. There should be at least three complete wraps of cable around winch drum in full down position. Cable anchor on winch drum must be tight.
4. Are all fasteners tight?
5. Are all belts and chain properly adjusted? (See Maintenance Section.)
6. Check oil levels in Gearbox and Enclosed Drive Unit. (See Maintenance Section.)

Obtain any needed replacement parts from your dealer and install before using the machine.

TRANSPORTING AUGERS

TRANSPORT: Moving the Auger with the Towing Vehicle to or from the Work Area.

1. HITCHING TO TOWING VEHICLE INSTRUCTIONS.

Make certain the hitch pin is securely attached and an alternate hitch safety chain is secure to the auger and towing vehicle. Check to see that the hitch is properly attached to the intake guard and that the bolt and nut holding it there are tight.

Never raise the intake end higher than is necessary to attach to a towing vehicle. Weight transfers rapidly to the head end when the intake is raised.

NOTE: Empty machine before moving to prevent upending.

Never stand between tractor and machine when hitching unless all controls are in neutral and the brakes locked.

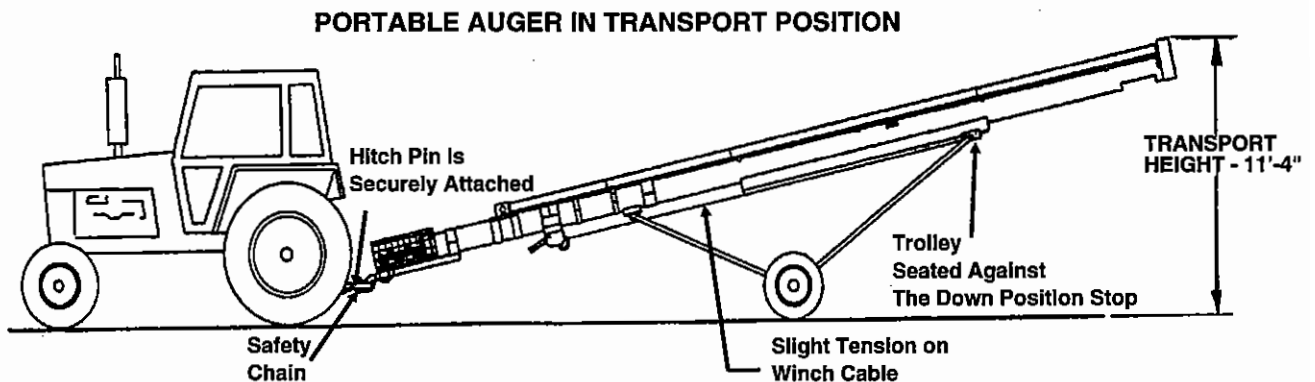

***IMPORTANT:** Transport heights are figured with auger attached to towing vehicle with a drawbar height of 1'-6". When the auger intake is resting on the ground, add 1'-6" to transport height of the auger to achieve the overall auger height.

ALTERNATE HITCH SAFETY CHAIN

An auxiliary attachment system (safety chain) is required to retain the connection between towing and towed machines in the event of separation of the primary attachment system.

The safety chain should be routed through the intake chain safety screen and around the bearing support at the lower end of the intake flight.

A clevis or intermediate chain support should be fastened to the tractor drawbar no farther than 6" from the hitch pin. (A hole is provided in the hitch pipe for this purpose.)

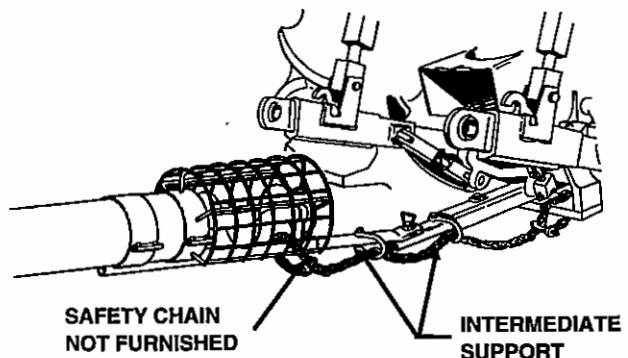

2. MOVING AUGER

Moving your portable auger requires careful planning. A route plan should be considered beforehand to avoid dangerous obstacles and loss of time.

Always transport your auger in the full down position. The lift arm of the undercarriage should be seated against the down position stop with slight tension on the winch cable and at least 3 complete wraps of cable around the winch drum.

TRANSPORTING AUGERS - (CONT.)

2. MOVING AUGER (CONT.)

Comply with your state and local regulations governing marking, towing, and maximum width. Observe safe driving and operating practices.

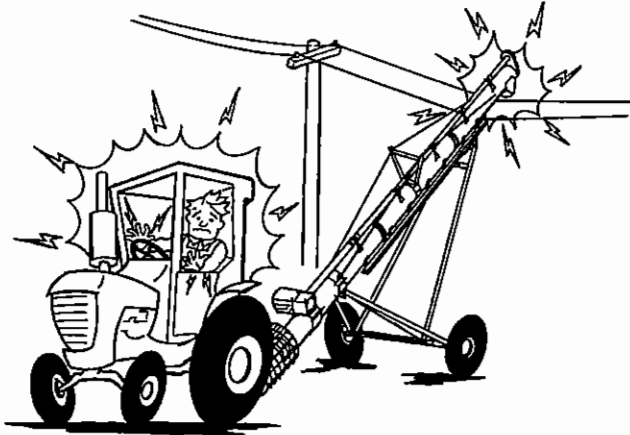

Be alert to overhead obstructions and electrical wires, particularly if towing height is greater than 13'-6". Failure to do so may result in electrocution. Lower auger well below level of power lines before moving. Maintain at least ten (10) feet of clearance. The transport height for this auger is 11'-4".

Never allow persons to stand underneath or ride on the auger when moving the auger. Make certain everyone is clear of the work area before moving.

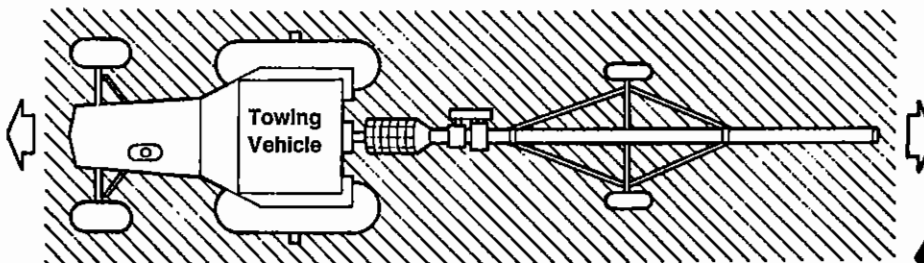

**WHEN MOVING AUGER.
HAZARD AREA - KEEP OUT**

PLACEMENT OF AUGER - UNLOADING GRAIN BIN

Placement - Move the auger into its working position with a towing vehicle.

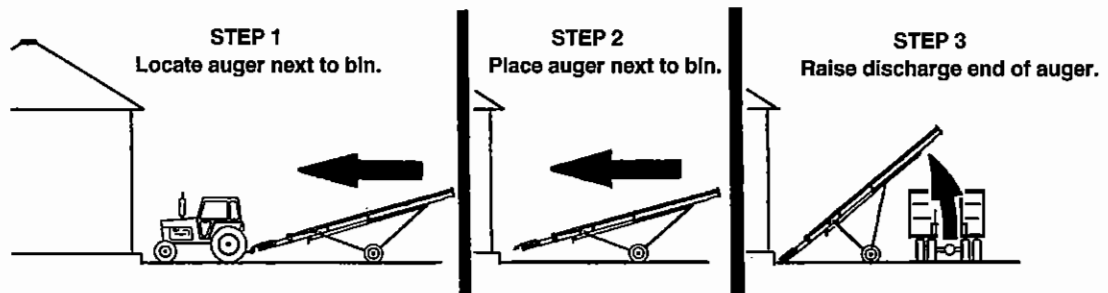

STEP 1

Locate the auger as close as possible to the bin or other structure. Move auger slowly towards working position with towing vehicle—not by hand. When moving the auger towards the working position leave adequate room for a convenient path for the necessary vehicles to reach the auger intake area.

Make certain everyone is clear of the work area when moving the auger. To prevent tip-over when backing, avoid rolling over any obstructions, also avoid steep slopes. If the auger is to sit on a slope, approach the bin up hill. Avoid moving the auger at right angles to a slope.

Make sure entire area above auger and in line of travel is clear of overhead obstructions and electrical wires. Failure to do so may result in electrocution. Maintain at least ten (10) feet of clearance. Electrocution can occur without direct contact.

STEP 2

Place auger intake next to bin or storage structure. When releasing from the towing vehicle, test the intake end for downward weight. Lower it slowly to the ground. **NOTE: Weight transfers rapidly to the head end if the intake is raised above the tow bar, particularly when the auger is in a raised position.** Remove bolt from hitch and fully retract hitch pipe. If a hopper is to be used, install at this time.

PLACEMENT OF AUGER - UNLOADING GRAIN BIN (cont.)

STEP 3

Raise the auger with winch.

TO RAISE THE AUGER WITH HAND WINCH

Turn the handle, clockwise (pull cable onto winch drum). There should be a clicking sound.

NOTE: The winch is equipped with a brake that is actuated by turning the handle. The brake is designed to hold the load whenever the handle is released.

NOTE: Observe the cable as it is winding onto the winch drum. The cable should roll up on the drum evenly; avoid cable build-up on one side of the drum.



Keep hands away from winch drum during operation.

DO NOT ATTEMPT TO INCREASE AUGER HEIGHT BY POSITIONING WHEELS ON LUMBER, BLOCKS OR BY OTHER MEANS.

Once in place the wheels should be chocked on both sides of auger so it will not roll. The auger should be anchored at the intake end and/or supported at the discharge end. This will prevent auger from tipping when weight transfers to top end as auger empties.

WINCH INSTRUCTIONS

HAND WINCH OPERATION (FRICTION TYPE)

Check the handle assembly on your auger to determine that it has been assembled correctly. See assembly section. There should be a locknut attached to the end of the winch shaft to prevent inadvertent removal of the winch handle.



Never fully extend the cable and always keep three complete turns of cable around winch drum.

Never operate winch with wet or oily hands and ALWAYS use a firm grip on the handle.

SAFETY REMINDERS

Operator must pay attention during raising and lowering auger.

- (A) Watch cable to see if it is coiling properly onto winch drum evenly.
- (B) Keep hands away from winch drum during operation.
- (C) Don't use hands to guide cable onto winch drum during winch operation.
- (D) Don't allow auger to become hung up.
- (E) Don't continue to raise auger after slide reaches stop.

TO LOWER AUGER WITH HAND WINCH

Turn the handle counter-clockwise; there will be no clicking sound. To stop while lowering the auger, turn the handle clockwise until you hear two clicks to lock brake. (About 6" movements of the handle.) Too light a load will not overcome the friction forces in the winch. **NEVER CONTINUE TURNING THE HANDLE COUNTER-CLOCKWISE IF THE CABLE DOES NOT KEEP MOVING OUT.** This will disengage the brake mechanism and can create an unsafe condition.



CAUTION: The brake disc will get HOT when lowering the auger too fast. If brake is smoking, or squeals, stop lowering and let brake cool for 15 minutes. DO NOT TOUCH BRAKE!

DESIGNATED WORK AREA

Before starting the auger, the designated work area should be established and properly marked. The following diagrams will show the manufacturer's recommended work areas. These areas shall be marked off with colored nylon or plastic rope hung as portable barriers to define the designated work areas.

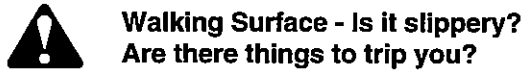

UNLOADING GRAIN BIN - PTO DRIVE UNIT

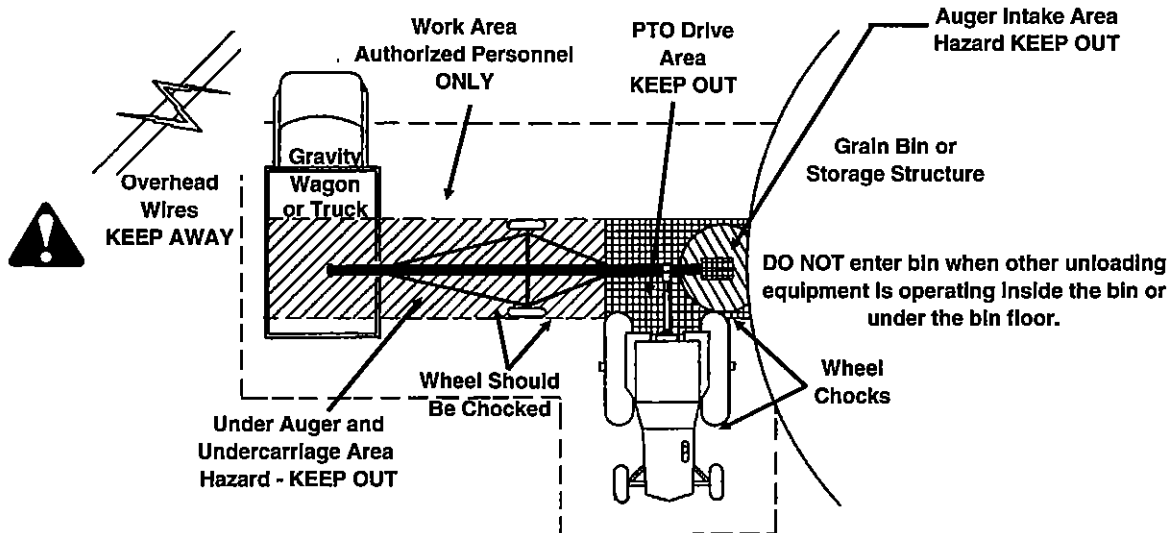

UNLOADING GRAIN BIN - ELECTRIC DRIVE UNITS

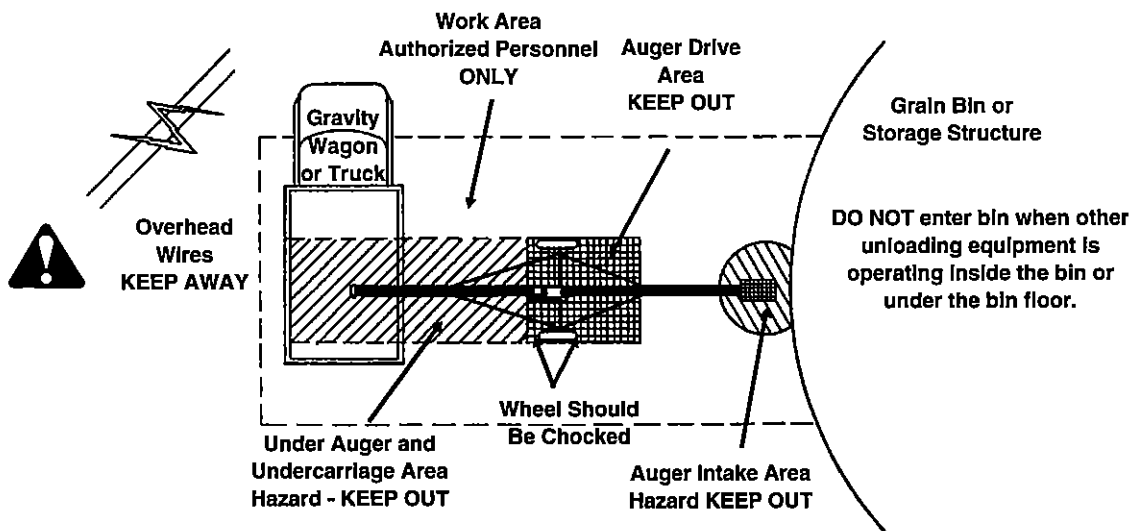

RULES FOR SAFE WORK AREA

Under no circumstances should persons not involved in the operation be allowed to trespass into the work area.



It shall be the duty of all operators to see that children and/or other persons stay out of the work areas! Trespass into the work area by anyone not involved in the actual operation, or trespass into a hazard area by anyone, shall result in an immediate shutdown by the operator.

It shall be the responsibility of all operators to see that the work area has secure footing, is clean and free of all debris, and tools which might cause accidental

OPERATING PROCEDURES

Start Up and Break-in Information

During the operation of your auger, one person shall be in a position to monitor the operation. Any screw conveyor when it is new or after it sets idle for a season should go through a "break-in" period. **DO NOT** operate the auger empty. The auger should be run at partial capacity until several hundred bushels of grain have been augered to polish the flighting assembly and tube. Once this has been accomplished, the auger can be run full.

Never operate the auger empty for any length of time as excessive wear will result. If at all possible, do not stop or start the auger under load, especially before the flight and tube become well polished, as this may cause auger to "freeze-up".

-  **During the initial start up and break-in period, the operator shall be aware of any unusual vibrations or noises.**
- Keep all safety shields and devices in place.**
- Keep hands, feet and clothing away from moving parts.**
- The operator should have a full view of the work area and check that all personnel are clear of Hazard Areas before adding Power.**

Proper auger flight speed is important for efficient operation of the auger.

1. If the flight speed is in excess of what is recommended, excessive wear will result.
2. If the flight speed is slow and the auger flighting is permitted to "load-up", the high torque will be required to turn the auger flighting, and damage to the auger can result. Under these conditions, use an optional control gate to control the amount of grain fed into the auger.

Recommended Auger Flight Speed

The chart below shows the "Recommended Auger Flight Speed" in relationship to "Gearbox Input Shaft Speed". The Gearbox Input Speed can be regulated by the pulley sizes used on the electric motor or by the PTO speed of the tractor. **NOTE: Use the tractor tachometer to determine the PTO speed which is the same as Gearbox Input Shaft Speed.**

IDEAL		MAXIMUM		MINIMUM	
Gearbox Input Shaft Speed	= Flight Speed	Gearbox Input Shaft Speed	= Flight Speed	Gearbox Input Shaft Speed	= Flight Speed
546 RPM	325 RPM	605 RPM	360 RPM	420 RPM	250 RPM

The 12" augers have a 1 to .59 drive ratio between the gearbox input speed and the auger flight speed.

It is essential to inspect your drive before adding power and know how to shut down in an emergency.

-  **SHUT OFF POWER AND LOCKOUT DRIVE TO ADJUST, SERVICE OR CLEAN.**

TOP MOUNTED ELECTRIC MOTOR DRIVES:

Use a 7 1/2 or 10 HP motor that operates at 1750 RPM. Use a 4.0 O.D. pulley on motor for an auger speed of 346 RPM.

Electric motors and controls shall be installed by a qualified electrician and must meet the standards set by the National Electrical Code and all local and state codes. Reset and Motor Starting Controls must be located so that the operators have full view of the entire operation.

A magnetic starter should be used to protect your motor when starting and stopping. It should stop the motor in case of power interruption, conductor fault, low voltage, circuit interruption or motor overload. Then the motor must be restarted manually. Some motors have built-in thermal over-load protection. If this type motor is used, use only those with manual reset.

CHECK THE FOLLOWING BEFORE ADDING POWER:

1. Check that belt guard is in place, secured and functional.

TO START AUGER

1. Start electric motor before conveying grain.

TO STOP AUGER

1. Let auger empty of grain before stopping.
2. Shut off electric motor and lockout.

NOTE: Motor pulleys are not furnished with the auger.

The horsepower recommendations are for augering reasonably dry grain at varying angles. High moisture grain (above 15%) will require greater horsepower. Maximum possible capacity will be less with high moisture grain than with dry grain.

-  **Disconnect power before resetting motor overloads.**
- Make certain electric motors are grounded.**

OPERATING PROCEDURES (CONT.)

PTO DRIVE INFORMATION

The Direct PTO Powered Drive may be driven from either side (as explained in the PTO Drive Assembly Section).

Only use an Agricultural Tractor with 540 RPM Power Take-Off.

Before starting the tractor, be certain power to PTO is off.

NOTE: The PTO driveline is equipped with a shear bolt at the tractor connection. The shear bolt protects the auger from damage if the auger becomes plugged or subjected to high loads.

NOTICE: The PTO driveline furnished with the auger is equipped with a "Spring-Lock" coupler at the tractor end. This type coupler is spring loaded and will fit the standard 1 3/8" x 6 spline PTO output shaft from a tractor.

CHECK THE FOLLOWING BEFORE ADDING POWER:

1. Be certain that the PTO driveline is securely attached to the auger and the tractor.
2. Always use a PTO driveline with a rotating shield in good working order that can turn freely on the shaft.
3. Align PTO driveline with tractor. The PTO driveline furnished with the auger is a pin stop type-that is, the two telescoping sections will not separate. It is a good practice to operate the driveline in as short a configuration as possible. Keep the PTO driveline in as straight a line as possible during operation. When connecting tractor and auger, always make sure the tractor axle and side of auger are parallel.

KEEP THE U-JOINT ANGLES EQUAL.

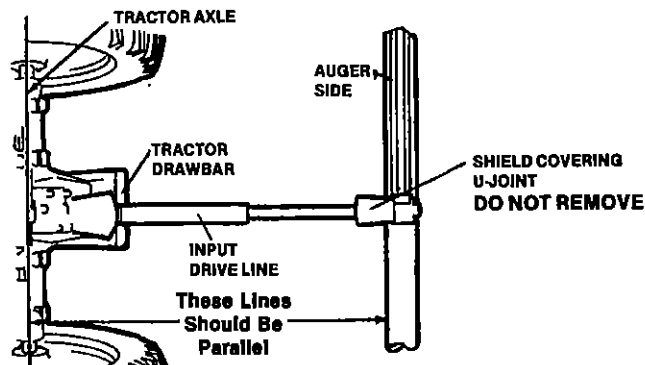

4. If the tractor and auger are on unlevel ground or at different levels, place them so the center line of the tractor and the gearbox shaft are parallel.

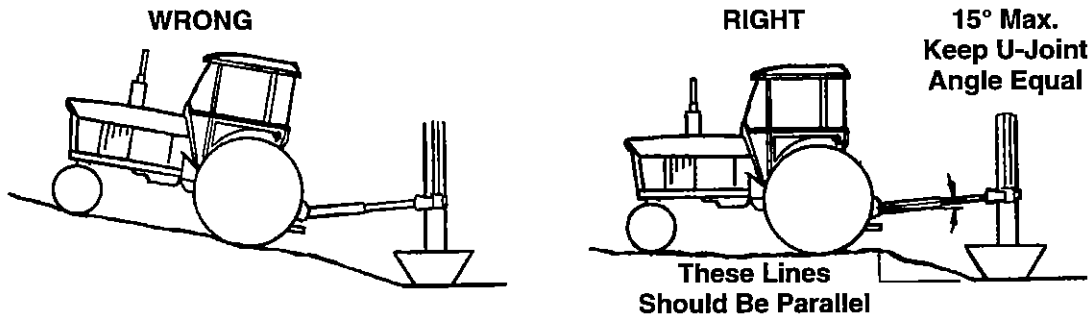

WHEN ADDING POWER:

The tractor operator should have a full view of the auger work area and check that all personnel are clear of hazard areas before adding power.



IMPORTANT: Engage PTO at a slow RPM to minimize shock loads. Then work up RPM to recommended speed.

OPERATING PROCEDURES

OPERATING CAPACITIES

Capacities of screw conveyors or augers can vary greatly under diverse conditions. Different materials, moisture content, amounts of foreign matter, angle of operation, methods of feeding and speed all play a role in performance of the auger. Roughly 5500 BPH will be achieved augering reasonably dry grain. Maximum possible capacity will be less with high moisture grain (above 15%) than with dry grain.

SHUTDOWN

A. NORMAL SHUTDOWN

Make certain that auger is empty before stopping the unit. Before the operator leaves the work area, the power source shall be locked out. (See Lockout.)

B. INTERMITTENT OPERATION SHUTDOWN

When an auger is stopped and restarted under full load, it may result in damage to the auger. Therefore, if intermittent operation is to be carried out, it is advisable to reduce the load level. When kept from absolute filling, auger start-up is easier and more efficient.

C. EMERGENCY SHUTDOWN

Should the auger be immediately shut down under load, disconnect and lockout the power source. Clear as much grain from hopper and auger as you can. Never attempt to start when full. Use clean-out doors when possible. When as much grain as possible has been cleared, reconnect power source and clear auger gradually.

NOTE: Starting the unit under load may result in damage to the auger. Such damage is considered abuse of the equipment.

LOCKOUT

If the operator must leave the work area, or whenever servicing or adjusting, the auger must be stopped and the power source turned off. Precaution should be made to prevent anyone from operating the auger when the operator is absent from the work area.

DIRECT PTO DRIVE: Remove ignition key or coil wire from power source. (If this is impossible, remove the PTO shaft from the work area.)

TOP MOUNTED ELECTRIC DRIVE: A main power disconnect switch capable of being locked only in the off position shall be provided.

OPERATING PROCEDURES

RELOCATION OF AUGER

When grain conveying operation is completed, the auger should be moved away from the bin and lowered. The auger then can be moved to a different bin for more conveying operations or cleaned up and stored.

Step 1

- A. Empty all grain from the auger and clean up area.
- B. Untie any anchors or remove all supports.
- C. Disconnect the power source.
 - Electric Drive** - Unplug electric motor, wind up electric cables.
 - PTO Drive** - Disconnect PTO driveline from tractor and place in support provided for transporting.
- NOTE: The bracket pin must be in place to hold the PTO driveline in the support during transporting.**
- D. Raise the auger so the discharge spout is clear of bin opening. See Winch Instructions on page 6.
- E. Remove hopper from auger intake and secure hitch in place with bolt and nut.
- F. Lift the auger intake and hitch to the towing vehicle. (See Hitching Instructions on page 4.)
- G. Remove wheel chocks.
- H. Move auger slowly away from the bin with towing vehicle--**NOT BY HAND.**

Step 2

- A. Immediately lower auger with winch. (See Winch Lowering Instructions on page 6.)
- IMPORTANT: Lower the auger, even if relocating to a bin in the immediate area.**

Step 3

- A. Move the auger to next bin or storage area. We recommend that the auger be stored in the full down position with intake end anchored.
- B. Inspect the auger as outlined in the "Machine Inspection Section" on page 3.

LUBRICATION AND MAINTENANCE

For economical and efficient operation of your auger, maintain regular and correct lubrication. Neglect leads to reduced efficiency, excessive wear and needless down time.

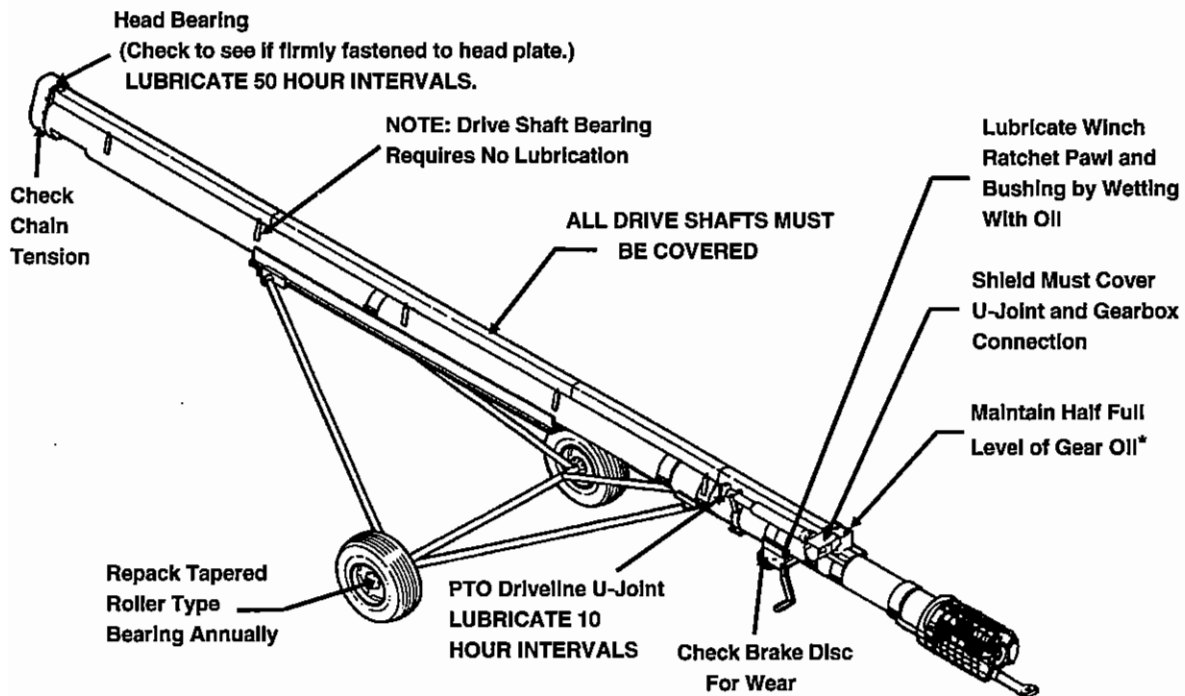

Keep all safety shields and devices in place.
Never clean, adjust or lubricate a machine that is in operation.

* GEARBOX

The gearbox is shipped without oil. At field assembly of auger, 90 E.P. (non-foaming) oil is to be added to the gearbox until half full. Check and maintain the level regularly.

LUBRICATION AND MAINTENANCE (CONT.)

PTO DRIVELINE WITH SHEAR BOLT

Augers equipped with PTO driveline should have the u-joints lubricated at approximately ten (10) hour intervals with SAE multipurpose type grease.



Before engaging PTO, be sure that PTO driveline shields turn freely on shaft.

The PTO driveline is equipped with a shear bolt at the tractor connection. The shear bolt protects the auger from damage if the auger becomes plugged or subjected to high loads. It is important to use the correct replacement bolt of the proper size and strength to insure that the shear device will protect the auger and operator. Order replacement shear bolt, Part No. 33046 - 5/16" x 18 x 1" long grade 5 bolts. Extra shear bolts are provided with the auger.

FRICTION TYPE WINCH

The following lubrication checks should be made to the winch periodically.

The auger should be in the lowered position with undercarriage lift arm slide against the upper head stop when this inspection is being performed. Refer to operating and maintenance instructions furnished with the winch for proper inspection methods. The winch is also illustrated on page P-7.

1. All gears should have a film of grease on them at all times.
2. The following parts must be wet with oil at all times:
 - (A) Two bushings located at ends of drum shaft.
 - (B) The ratchet pawl
 - (C) Two bushings located at ends of pinion shaft.

IMPORTANT: Do not get oil or grease on brake disc faces (located between ratchet gear, brake hub and pinion shaft.)
3. Check brake disc, if worn to less than 1/16 of an inch thick, replace both discs.

BEARINGS

Undercarriage Axle Spindle Bearing

Tapered roller type bearings are standard and should be repacked with grease and adjusted annually or as needed, determined by usage.

TAPERED ROLLER TYPE BEARING ASSEMBLY

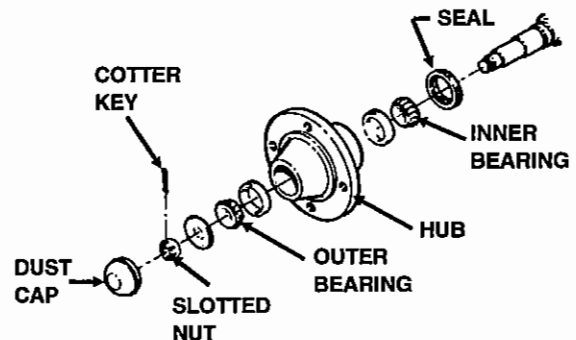

Care must be used in dismantling wheel bearings assembly. First remove the dust cap by prying around its edges. Remove the cotter pin, slotted nut and flat washer. Carefully remove the hub and bearings from the spindle. Inspect all parts for wear or damage and replace with new ones if necessary.

When reassembling the hub, repack both bearing cones with grease and fill the hub cavity 1/3 full. Place inner bearing assemblies into the hub, and then press grease seal into hub and carefully reinstall the hub on the spindle. When placing hub on spindle be careful not to damage the lip of the grease seal. Install outer bearing assembly into the hub, and replace flat washer and slotted nut. Tighten the slotted nut to seal the bearings until the hub binds as you rotate hub. Back off the slotted nut to the next slot and pin with a new cotter pin. Use a 5/32" cotter pin 1-1/4" long. Replace dust cap.

HEAD BEARING

Head bearings at the discharge end are supported by self-aligning, sealed ball bearings which have been packed at the factory, but operator should lubricate at approximately fifty (50) hour intervals. Lubricate lightly with SAE multipurpose type grease. Check that bearings are firmly fastened to the head plate and that the lock collars are secured to the shaft.

The head bearings use an eccentric type lock collar. To tighten this type of lock collar, first slide it against cam end of the inner ring of the bearings. Engage cams by rotating collar until it slides over cammed end of inner ring. Lock the collar by tapping lightly in direction of shaft rotation, then tighten setscrew.

DRIVE SHAFT BEARINGS

All drive shafts are supported by self-aligning, sealed ball bearings, which have been packed at the factory and require no further lubrication. There is no adjustment to be made to the bearings but to check that the retainers are firmly fastened to the bearing stands.

IMPORTANT: The complete drive shaft must be shielded with drive shaft covers during operation.

LUBRICATION AND MAINTENANCE (CONT.)

BEARINGS - CONT.

INTAKE GUARD BRONZE BEARING

Every auger has a bronze-with-graphite bearing at the intake end. This bearing requires no lubrication. If wire guard is damaged, replace the intake guard.

HEAD DRIVE CHAIN

The enclosed drive is located at the discharge end of the auger housing and is shipped without oil. Oil is to be added to the unit during field assembly of the auger. Oil will dissipate under normal operating conditions, therefore the oil level should be checked regularly. Add 90 EP (non-foaming) oil until the level of the oil reaches the check port.

For lubrication in normal operating temperature between 40°F to 120°F, we recommend the use of non-foaming, multi-purpose gear oil, SAE 90 weight. For temperatures below 40°F, use SAE 80 weight oil. Use grade commercially available for automotive differentials. Extra pressure additives may be of value in severe applications.

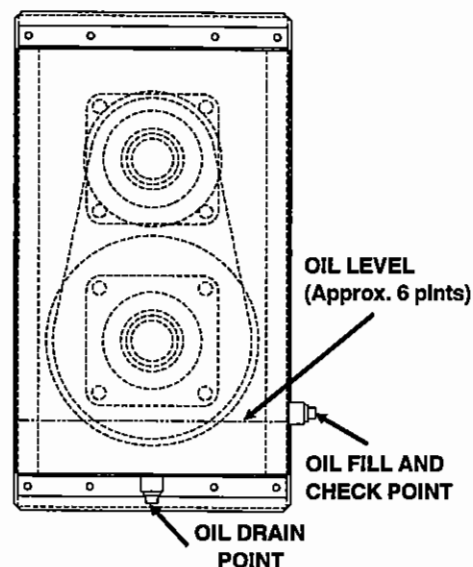

TROUBLE SHOOTING

LOW CAPACITY

The auger may not be getting enough grain. Check to see the intake has not "bridged over" restricting the flow.

The exposed flighting at the auger intake should be covered with grain to achieve maximum capacity.

Check auger speed. Refer to page 8. A slow speed (below recommended speed) will result in low capacity.

AUGER PLUGS

The auger may be getting too much grain where it is "jamming" inside the housing.

On motor drive augers, the motor may be too small or wired improperly.

If wet grain or other hard to move material is being augered, use a larger size motor than recommended for normal use.

Is the auger free of any foreign material, such as sacks, tarp corners, etc.? A plug of the discharge end will cause an auger plug.

Check to see that all belts and chains are lined up and tensioned properly.

EXCESSIVE AUGER NOISE

Damage may have occurred to the auger flighting, thus causing noise. Damage usually occurs because of foreign material having been run through the auger. It may be necessary to remove the flighting for inspection.

IMPORTANT:

An auger should be frequently checked and serviced to operate freely. Keep all guards and shields in place. Replace any that are damaged or lost. An auger should be run partially full for several hundred bushels to polish the flighting when it has not been used for an extended period of time. An auger with flighting that has not been polished in this manner requires greater horsepower, and damage to the drive and/or flighting can result if overloaded.

Our augers are well made and we are proud of our line of equipment. We would like you, as our customer, to do your part in using caution and good judgement in using our equipment, as well as any other machinery. Any parts for replacement should be replaced with parts of the same type and size. Do not modify or alter any of the auger components.

ASSEMBLY INSTRUCTIONS

Choose an open level surface accessible to chain hoist or other lifting devices where the auger may be laid out full length.

INTAKE GUARD

Install intake guard assembly at intake end of auger. Slide the assembly over the flighting and the housing. Insert intake stub shaft through the bearing and clamp the assembly to the auger housing. Top upper half band should be above welded stop. See Figure 1.

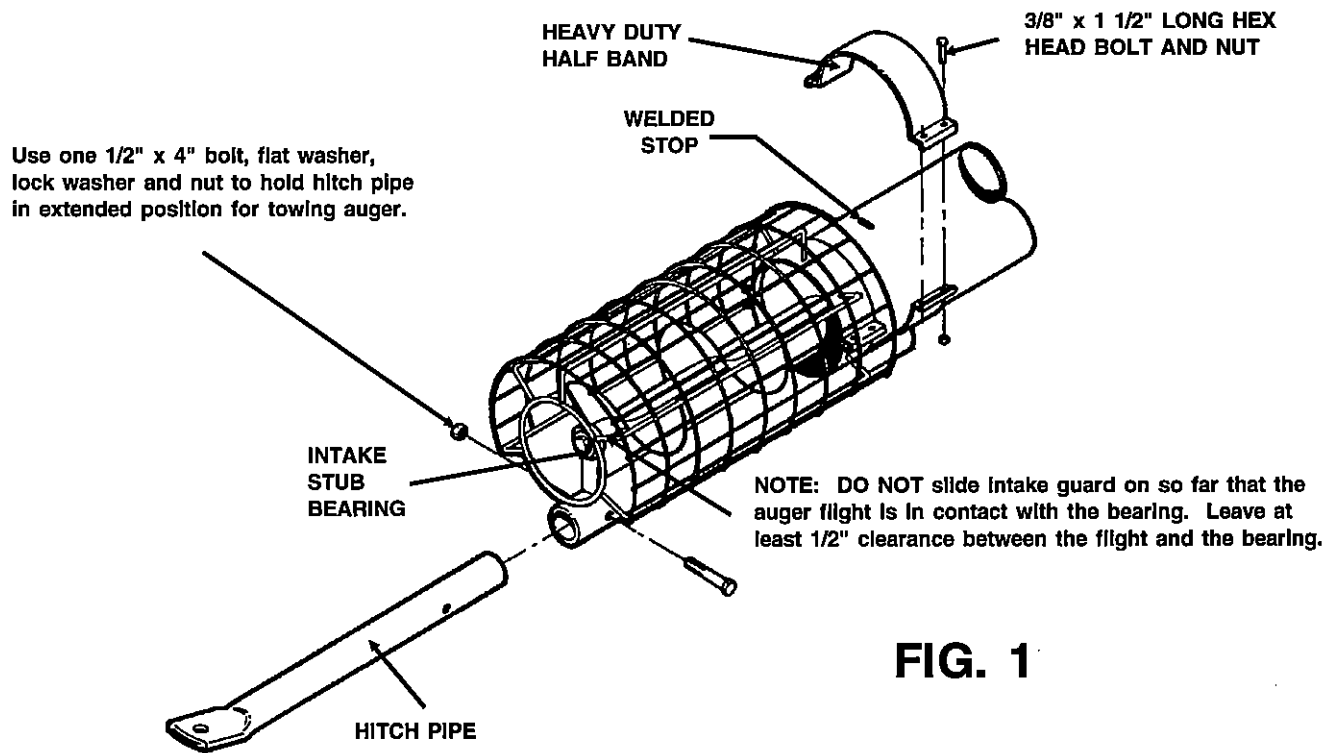

FIG. 1

ASSEMBLY INSTRUCTIONS (CONT.)

DRIVE SHAFT EXTENSION ASSEMBLY FOR P.T.O. DRIVE ONLY

1. Bolt bearing to bearing stands. Attach each bearing using two retainers. See Fig. 2.

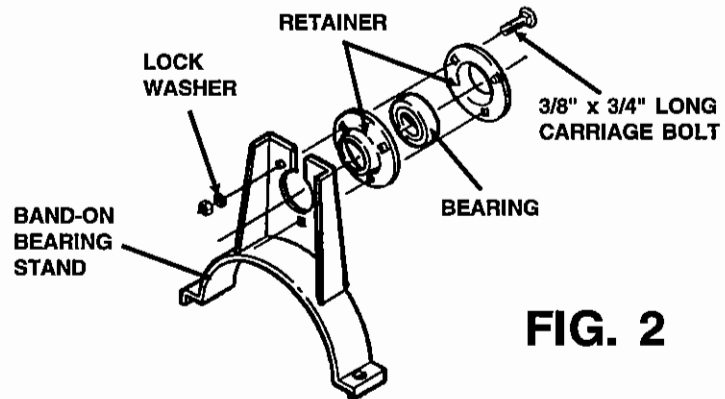

FIG. 2

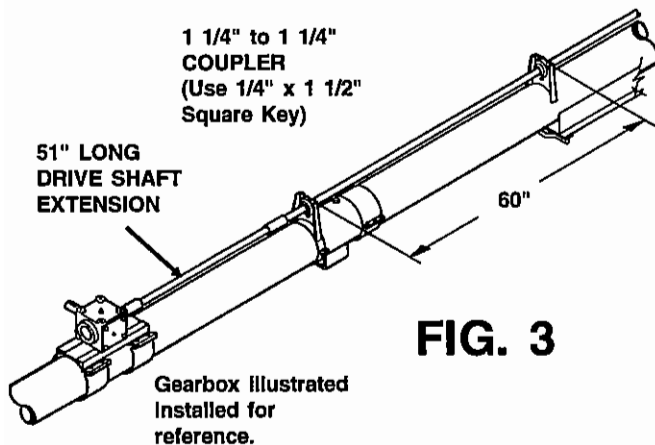

FIG. 3

2. Slide bearing stands onto extension drive shaft. Attach extension drive shaft to auger drive shaft using a coupler and two 1/4" x 1 1/2" square keys. See Fig. 3 for correct bearing stand spacing. Fasten bearing stands in place, using halfbands and 5/16" x 1 1/2" bolts and nuts. Tighten two bearing setscrews to lock bearing to extension drive shaft.

GEARBOX ASSEMBLY

Gearboxes are equipped with two oil fill plugs. One plug is vented and must always be on the top side of the box. **ADD 90 EP** (non-foaming) oil until the gearbox is half full. Attach gearbox to mount.

Set gearbox on auger and connect to drive shaft with coupler. Mount gearbox for left drive.

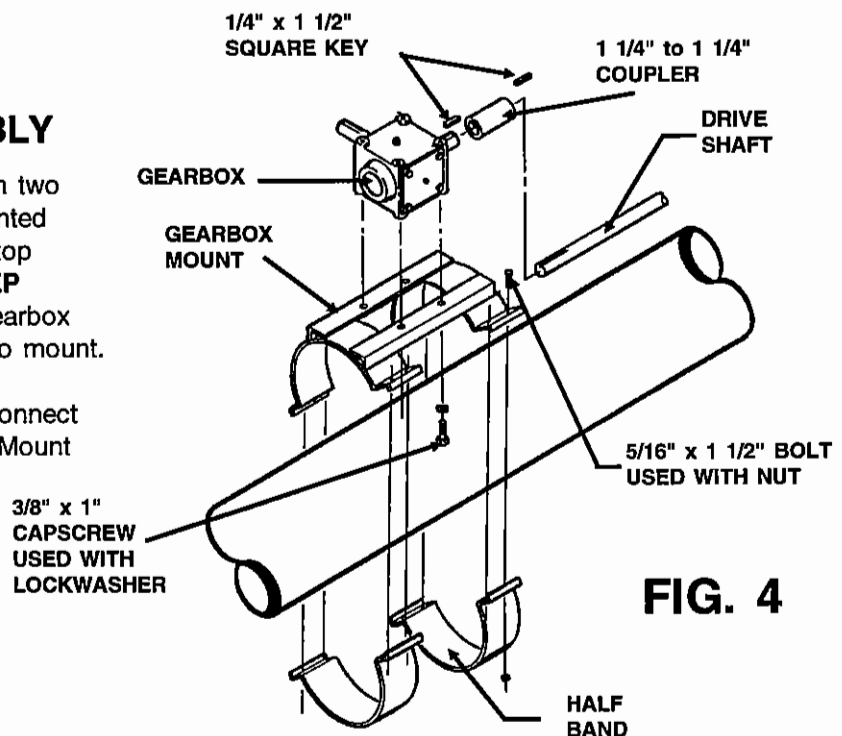

FIG. 4

ASSEMBLY INSTRUCTIONS (CONT.)

DRIVE SHAFT COVERS

The covers should be placed on the auger while it is lying on the ground before it is placed on the undercarriage. **PLEASE**, remember these covers provide important protection for persons around an auger that is in operation. Proper installation is important.

1. Install drive shaft cover to gearbox bracket to the top of the gearbox. See Fig. 5.

3/8" x 3/4" CAPSCREW WITH LOCKWASHER

DRIVE SHAFT COVER TO GEARBOX BRACKET

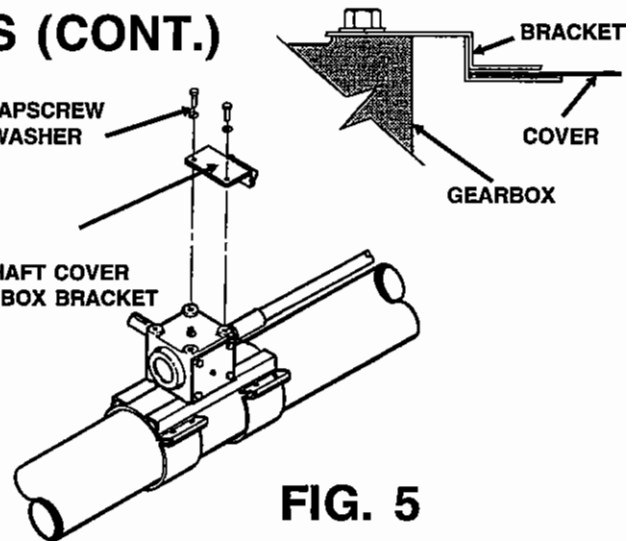

FIG. 5

2. Note that each drive shaft cover is slightly wider at one end. This wider end is the lower end of each cover. Begin at the lower end, setting each cover over the one before it. See Chart below for proper sequence. The covers are longer than distances between bearing stands causing them to overlap. Even out overlap at all joints. Lock covers in place with mounting clips and 1/4" x 1" bolts, lockwashers and nuts. Leave bolts loose on lower end of first cover installed.

P.T.O. DRIVEN AUGER

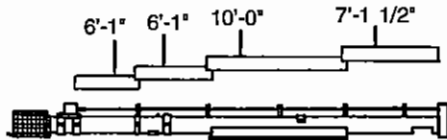

FIG. 6

ELECTRIC MOTOR DRIVEN AUGER

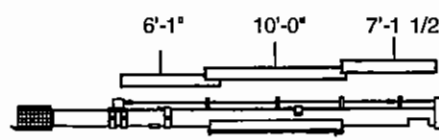
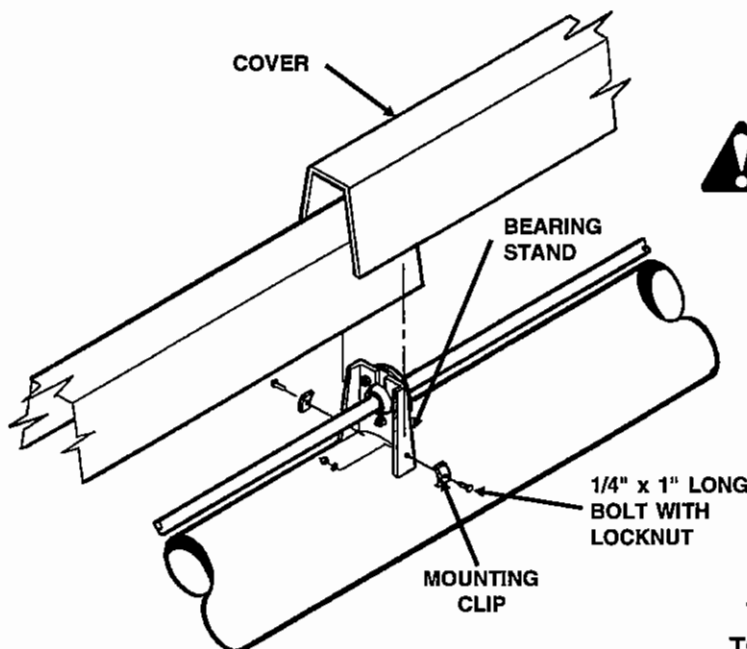

FIG. 7



CAUTION: Keep all safety shields and devices in place.

FIG. 8

TYPICAL DRIVE SHAFT COVER TO BEARING STAND ASSEMBLY

ASSEMBLY INSTRUCTIONS - CONT.

HUB AND SPINDLE TO UNDERCARRIAGE ASSEMBLY

The 4-bolt hubs, bearings, seals and spindles are assembled at the factory and are pressure packed with grease at that time. Slide the 4-bolt hub and spindle assembly into the undercarriage axle and secure with bolt and locknut.

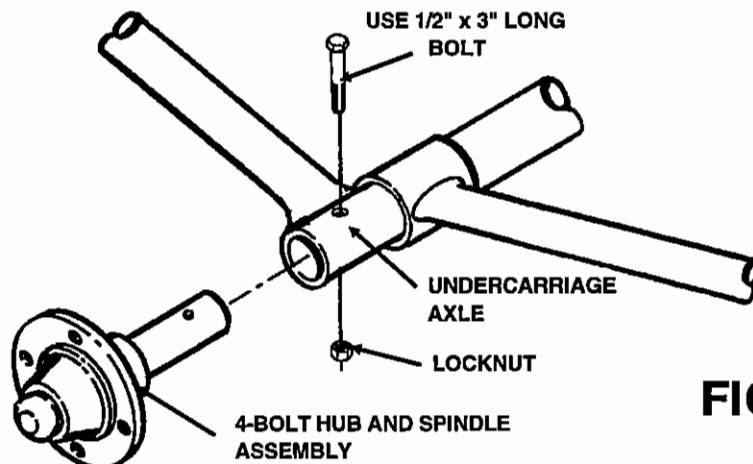

FIG. 9

UNDERCARRIAGE ASSEMBLY

Lift the auger assembly a few feet by lifting at a point near the center of the auger with a chain hoist or other safe, suitable means, **DO NOT** lift the entire weight of the auger from the extreme end. **DO NOT** use drive shaft to lift auger. Use a sling completely around auger tube assembly for lifting. Install the undercarriage slide onto the track from the discharge end. Be sure the undercarriage is installed on the track in a manner whereby it cannot be removed from the track after the stop has been installed. See Fig. 10.

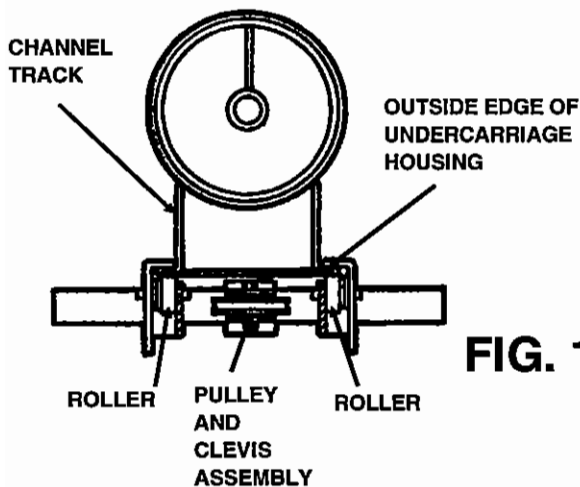

FIG. 10

UPPER UNDERCARRIAGE STOP

IMPORTANT: A stop must be bolted on the discharge end of undercarriage track. Use four 1/2" x 1 1/4" capscrews with lockwashers.

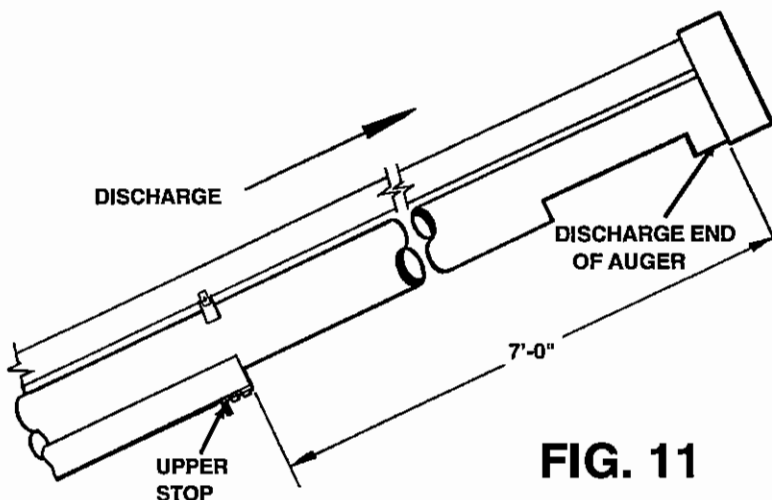

FIG. 11

ASSEMBLY INSTRUCTIONS - CONT.

LOWER UNDERCARRIAGE ARM TO AUGER HOUSING ASSEMBLY

Position undercarriage below auger and bolt the lower arm of the undercarriage to the auger. Use four 1/2" x 1 1/4" bolts and lock nuts to attach lower undercarriage mounting plate to mount on auger. See dimension in Fig. 12 to insure location of mount.

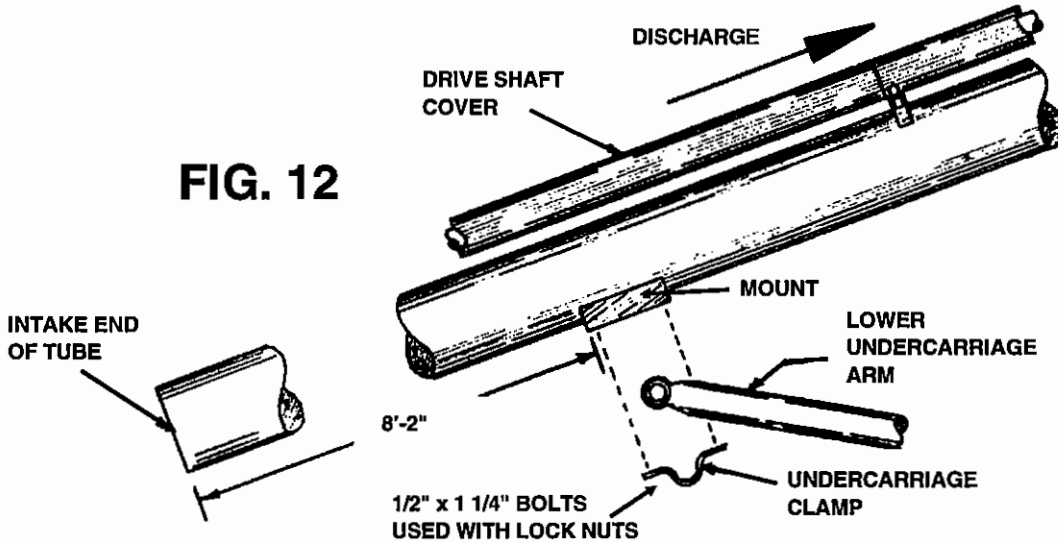

FIG. 12

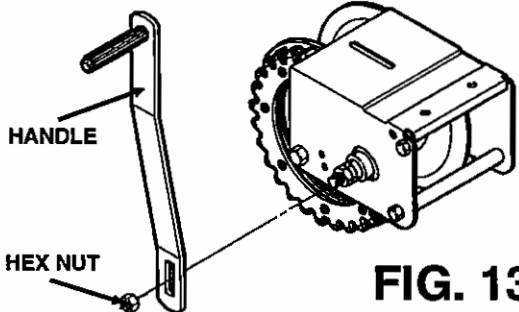

FIG. 13

WINCH HANDLE ASSEMBLY

Align slot of handle with flat portion of winch pinion shaft. Use hex nut to hold handle in place and tighten securely. See Fig. 13. It is important that the handle is properly installed for the winch brake to work properly. For additional winch information, follow the instructions and precautions listed in the material supplied with the winch from the manufacturer.

WINCH TO CABLE ASSEMBLY

Attach 1/4" x 44' long lift cable will wrap over winch drum when turning handle in a clockwise direction. From inside of drum, insert the cable through one round hole in the drum side, until it extends 1" past two square holes. Next clamp the cable to the outside of the drum with the cable keeper, using two 3/16" x 3/4" carriage bolts, lockwashers and nuts. Be sure that the carriage bolt heads are on the inside of the drum. See Fig. 14.

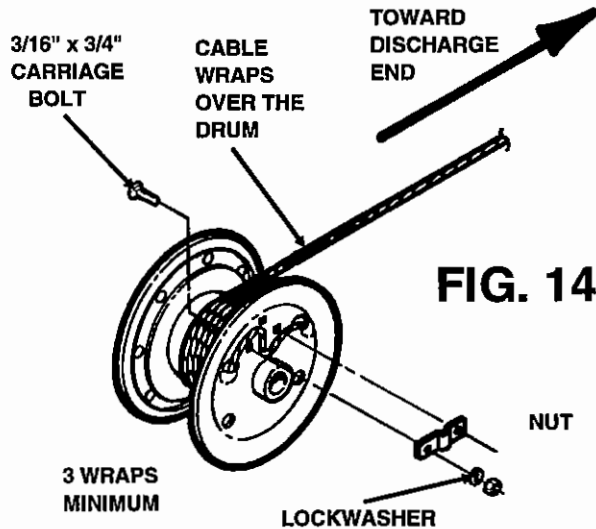
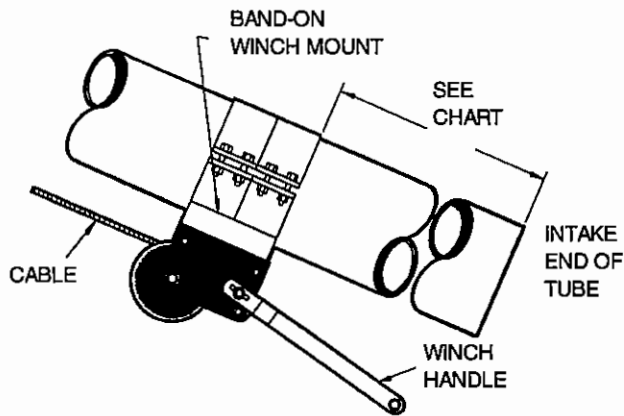

FIG. 14

ASSEMBLY INSTRUCTIONS - CONT.

WINCH TO AUGER ASSEMBLY

1. Bolt winch assembly to band-on mount. Use three (grade 5) 3/8" x 1" bolts, flat washers, lockwashers and nuts to attach winch to mount. See Fig. 15.
2. Attach band-on winch mount to auger tube so the winch drum is toward the auger discharge. See Fig. 15 for proper location. Use eight 5/16" x 1 1/2" hex head capscrews and nuts to secure halfband together.



DRIVE	DISTANCE FROM INTAKE END OF TUBE TO MOUNT
PTO	5'-0"
ELECTRIC	3'-5"

FIG. 15

WINCH CABLE ASSEMBLY

Install cable to undercarriage slide. Secure cable with two cable clamps with the clamp u-bolt against the loose end of the cable.

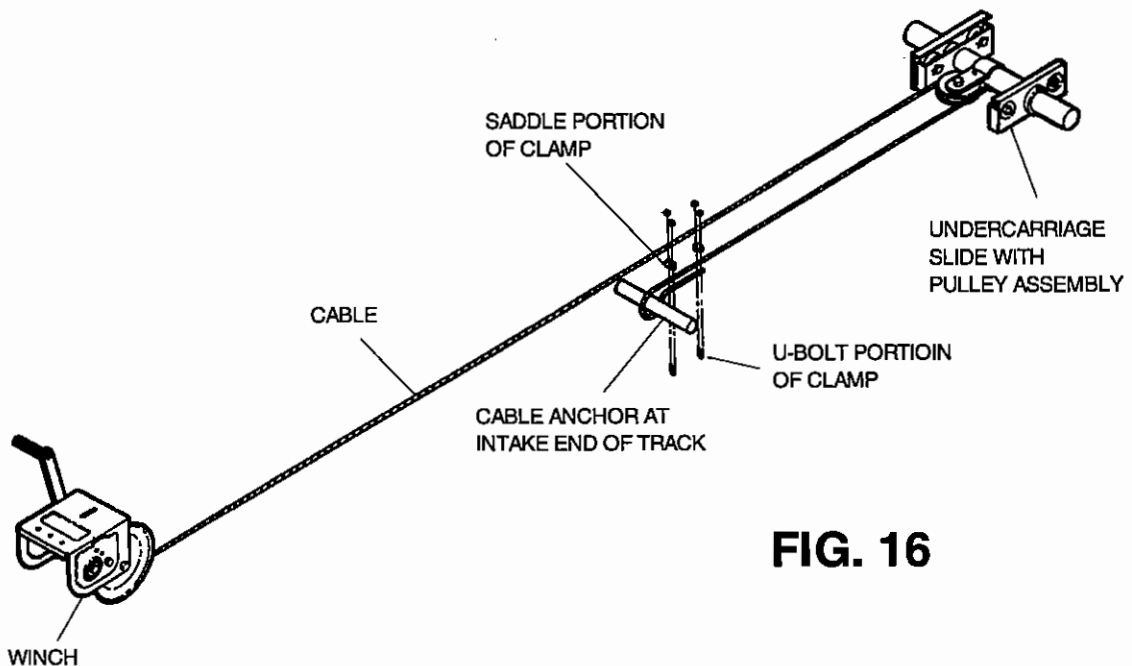

FIG. 16

ASSEMBLY INSTRUCTIONS (CONT.)

P.T.O. DRIVE ASSEMBLY

NOTE: P.T.O. Drives can be driven from either the right or left hand side of the auger. ALL ILLUSTRATIONS SHOW GEARBOX IN LEFT DRIVE POSITION.

To change the drive for a right hand drive, turn the gearbox over so the opposite side can be bolted to the gearbox mount. The vent plug in the gearbox must be moved to the opposite (top) side of the box before bolting to mount. The PTO driveline support is installed on the other side of the auger housing.

Attach PTO driveline to gearbox, then install input shaft shield over coupling. See Fig. 18.

IMPORTANT: For the setscrews to be properly engaged on the gearbox shaft, one set-screw will sit on the flat portion of the shaft and the other setscrew on the 1/4" x 1 1/2" long key. DO NOT extend the input shaft beyond the inside end of yoke. (See Fig. 19.)

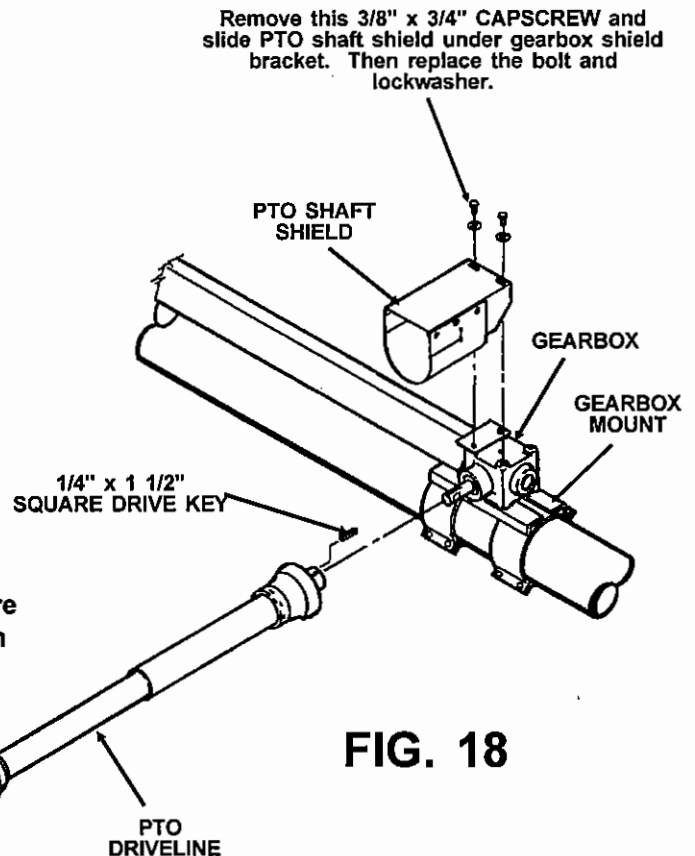
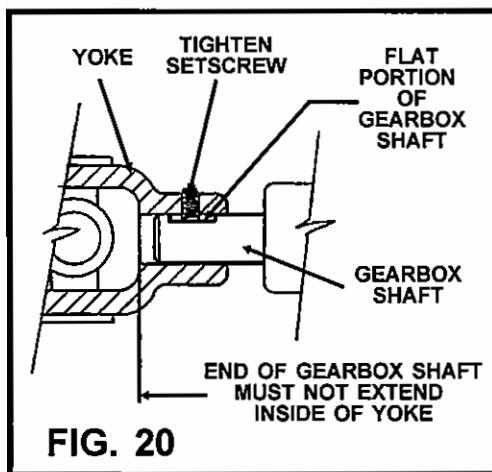

Before engaging P.T.O. be sure that PTO driveline shields turn freely on shaft.

The PTO driveline is equipped with a shear bolt at the tractor connection. The shear bolt protects the auger from damage if the auger becomes plugged or subjected to high loads. It is important to use the correct replacement bolt of the proper size and strength to insure that the shear device will protect the auger and operator.

Order replacement Shear Bolt, Part No. 33046 - 5/16" - 18 x 1" long Grade 5 bolt.

ASSEMBLY INSTRUCTIONS (CONT.)

PTO DRIVELINE SUPPORT

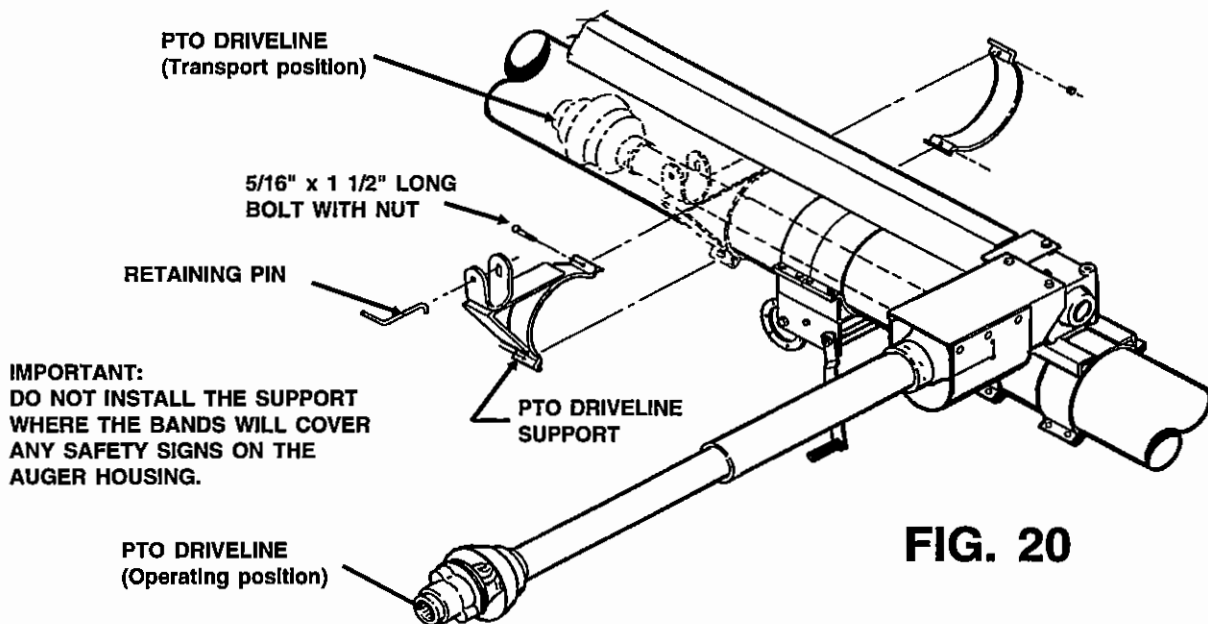

Place the PTO driveline support 46" from the center of the gearbox (toward the discharge end). Secure it to the auger housing with half band and two 5/16" x 1 1/2" hex head capscrews with nuts. Align the support so the driveline (when in transport position) will be parallel to the drive shaft covers. See Fig. 20 above. Set PTO driveline into the support to be sure the support is installed properly. Install the retaining pin by slipping the short bent end of the pin through the hole in the PTO driveline support and through the slot on the other side. Allow the long end of pin to rotate down, this will secure pin in place. See Fig. 20 above.

TO DEALER/ASSEMBLER

The assembly of the auger is complete if all the applicable assembly steps in this manual have been followed.

Before delivery to the owner it is a good practice to check the following:

- Be sure all safety shields and devices are installed properly.
- Check all safety decals to see if they are clean and readable. If any are missing, damaged, painted over, etc. replace them. See page P-1 for safety sign locations. Decals may be obtained from your dealer, distributor or ordered from the factory.
- Check all bolts and fasteners to see they are tightened and secured properly.

Deliver this Operator's Manual to the owner along with the auger.

TO THE OWNER

Use the Assembly Section of this manual as a reference to determine that the auger is assembled properly.

SAFETY SIGNS AND DECALS

Check all safety signs and replace any that are worn, missing or illegible. The safety sign locations are shown below. Copies of the safety signs are shown on page P-2 and P-3. Safety signs may be obtained from your dealer or ordered from the factory.

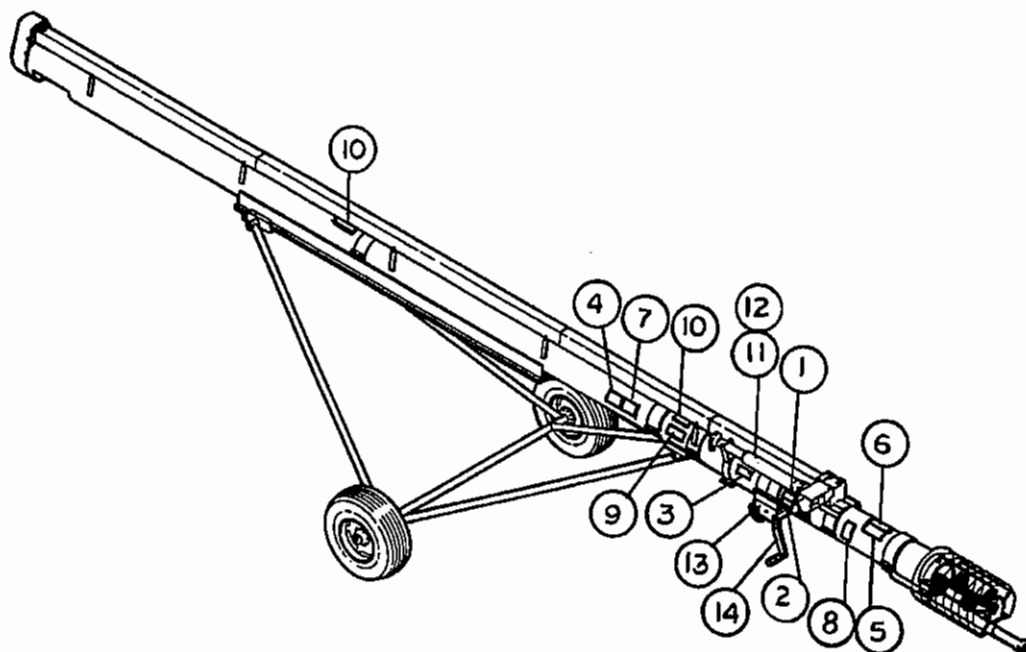

REF. NO.	PART NO.	QTY.	DESCRIPTION	SIZE
1	1001973	1	CAUTION - GENERAL STATEMENTS 1-8 One on side of Auger Housing	4 3/4 x 8
2	1001980	1	DANGER - BEWARE OF POWER LINES One on side of Auger Housing	4 x 8
3	1001978	1	WARNING - HAND WINCH OPERATION One on Auger Housing	4 x 7 1/4
4	1005324	1	DANGER "STOP" IF ANY GUARDS, SHIELDS One on side of Auger Housing	4 x 6
5	1001981	1	DANGER - UPENDING HAZARD One on Auger Housing	4 1/2 x 6 1/4
6	1001985	1	DANGER - ROTATING AUGER One on Auger Housing	4 1/2 x 6 1/4
7	1001984	1	DANGER - DO NOT ATTEMPT DISASSEMBLY One on side of Auger Housing	4 x 6
8	1001983	1	DANGER- ROTATING DRIVELINE One on both sides of Auger Housing	4 x 6 1/4
9	1001982	2	DANGER - ROTATING SHAFT One on side of Auger Housing	4 x 7 1/4
10	1001987	2	DANGER - DO NOT REMOVE COVER Near Internal Bearing Inspection Opening	4 x 6
11	13-10022	1	DANGER - SHIELD MISSING Under PTO DriveLine Shield	--
12	13-10021	1	DANGER - ROTATING DRIVELINE On PTO Driveline Shield	--
13	1002805	1	CAUTION - CABLE OUT/CABLE IN	--
14	2169A1	1	CAUTION - WINCH OPERATION On Hand Winch Handle	--

SAFETY SIGNS (Cont'd.)

1

⚠ CAUTION

1. READ AND UNDERSTAND THE OPERATOR'S MANUAL BEFORE OPERATING.
2. DO NOT REMOVE OR MODIFY ANY GUARDS.
3. MAKE CERTAIN EVERYONE IS CLEAR BEFORE OPERATING OR MOVING THE MACHINE.
4. KEEP HANDS, FEET, HAIR AND CLOTHING AWAY FROM MOVING PARTS.
5. STOP MACHINE AND LOCKOUT POWER TO ADJUST, SERVICE OR CLEAN.
6. EMPTY MACHINE AND LOWER TO TRANSPORT POSITION FOR TRANSPORTING.
7. DO NOT ATTEMPT TO MOVE MACHINE MANUALLY. USE A TOWING VEHICLE.
8. KEEP CHILDREN WELL CLEAR OF WORK AREA.

3

⚠ WARNING



(FOR HYDRAULIC OR ELECTRIC WINCH OPERATION, PLEASE REFER TO THE OPERATOR'S MANUAL PROVIDED WITH UNIT.)

- AFTER LOWERING THE UNIT, ALWAYS TURN THE WINCH HANDLE CLOCKWISE UNTIL YOU HEAR AT LEAST TWO CLICKS. THIS TIGHTENS THE BRAKE LOCK.
- MAINTAIN CONTROL OF WINCH HANDLE AT ALL TIMES.
- DO NOT PUT LUBRICATION OF ANY KIND ON THE BRAKE DISC.
- CHECK CABLE BEFORE EACH USE. REPLACE IF FRAYED OR DAMAGED.
- MAINTAIN LIGHT CABLE TENSION WHEN TRANSPORTING.

FAILURE TO HEED WILL RESULT IN SERIOUS INJURY OR DEATH!

2

⚠ DANGER

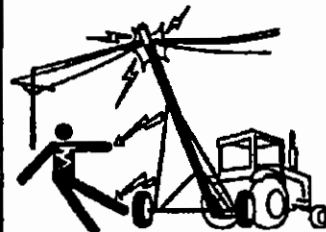

**BEWARE OF POWER LINES
ELECTROCUTION HAZARD**

- THIS MACHINE IS NOT INSULATED.
- KEEP AT LEAST 10 FEET AWAY FROM OVERHEAD ELECTRICAL WIRES.
- ELECTROCUTION CAN OCCUR WITHOUT DIRECT CONTACT.

FAILURE TO HEED WILL RESULT IN SERIOUS INJURY OR DEATH!

4

⚠ DANGER



IF ANY GUARDS, SHIELDS OR SAFETY DECALS ARE DAMAGED OR MISSING, ORDER FREE REPLACEMENTS BY CALLING

1-800-523-6993
OR WRITE TO:
HUTCHINSON/MAYRATH
P.O. BOX 629
CLAY CENTER, KANSAS 67432

5

⚠ DANGER



UPENDING HAZARD

- SUPPORT DISCHARGE END OR ANCHOR INTAKE END TO PREVENT UPENDING.
- EMPTY MACHINE BEFORE MOVING.
- DO NOT PUSH THE UNDERCARRIAGE BY HAND.
- LIFT THE INTAKE END SLOWLY AND NEVER HIGHER THAN VEHICLE TOW BAR. MAINTAIN CONTROL UNIT, SECURELY ATTACHED TO TOW BAR OR RESTING ON THE GROUND.
- LOWER TO TRANSPORT POSITION IMMEDIATELY WHEN CLEAR FROM GRAIN STORAGE STRUCTURE.

FAILURE TO HEED WILL RESULT IN SERIOUS INJURY OR DEATH!

6

⚠ DANGER



ROTATING AUGER

- KEEP HANDS, FEET, HAIR AND CLOTHING AWAY FROM ROTATING AUGER.
- DO NOT REMOVE OR MODIFY ANY GUARDS.
- KEEP CHILDREN WELL CLEAR OF WORK AREA.

FAILURE TO HEED WILL RESULT IN SERIOUS INJURY OR DEATH!

8

⚠ DANGER



ROTATING DRIVELINE

- KEEP BODY, HAIR AND CLOTHING AWAY FROM ROTATING DRIVELINE.
- USE ONLY WITH AGRICULTURAL TRACTOR HAVING 540 RPM POWER TAKE OFF.
- KEEP ALL DRIVELINE, TRACTOR AND EQUIPMENT GUARDS IN PLACE.
- MAKE SURE DRIVELINE ARE SECURELY ATTACHED AT BOTH ENDS.
- MAKE SURE DRIVELINE SHIELDS TURN FREELY ON DRIVELINE.
- KEEP U-JOINT ANGLES SMALL AND EQUAL.
- KEEP CHILDREN WELL CLEAR OF WORK AREA.

FAILURE TO HEED WILL RESULT IN SERIOUS INJURY OR DEATH!

SAFETY SIGNS (Cont'd.)

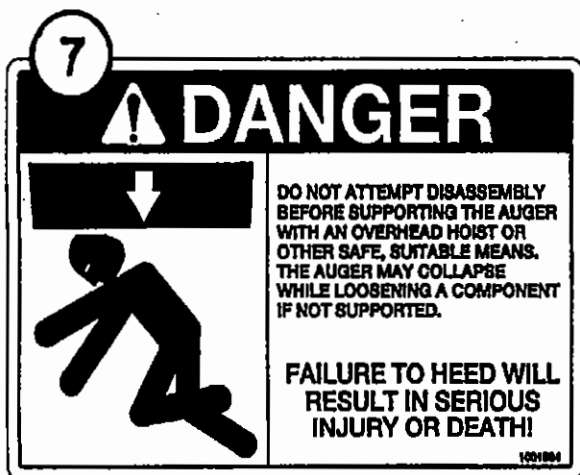

13

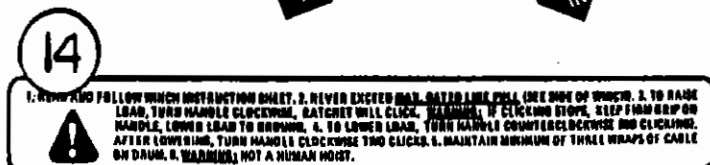

MAIN AUGER COMPONENTS

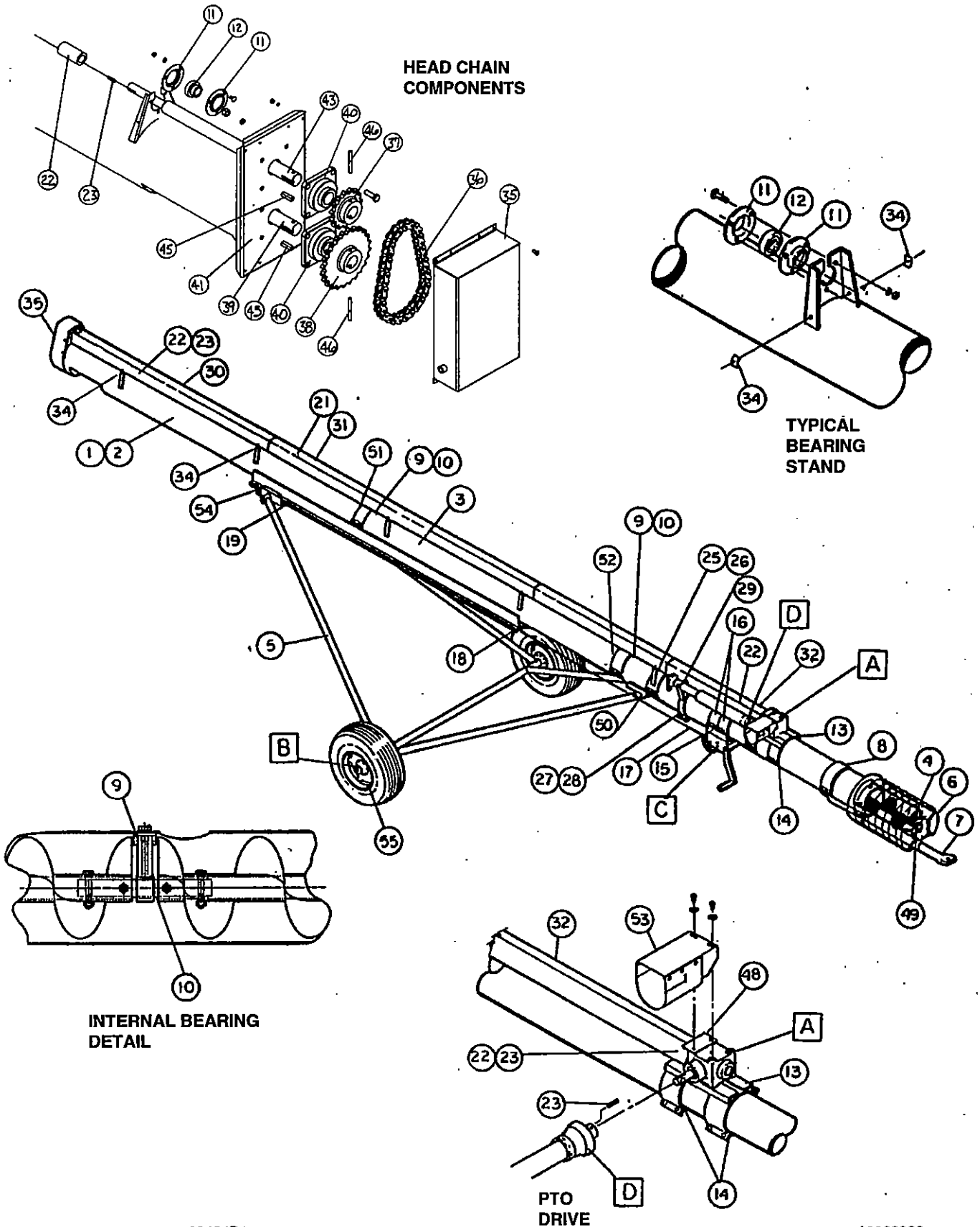

MAIN AUGER COMPONENTS

REF. NO.	PART NO.	DESCRIPTION	REF. NO.	PART NO.	DESCRIPTION
A	1006130-1	Gearbox (See Page P-6 for parts breakdown)	29	3338A1	Transport Bracket Retaining Pin
B	1001563	Spindle & Hub Assembly 4-Bolt (See Page P-7 for parts breakdown)	30	5146A1	Drive Shaft Cover 7'-1 1/2" Ig.
C	40301	Winch K-2550 Brake Type (See Page P-7 for parts breakdown)	31	5147A1	Drive Shaft Cover 10'-0" Ig.
D	1002172	PTO Driveline (See Page P-8 for parts breakdown)	32	5145A1	Drive Shaft Cover 6'-1" Ig. f/PTO Drive
1	1018434-230	Tube Housing (with Head Plate) (30' Ig.) (Hutch)	33	5145A1	Drive Shaft Cover 6'-1" Ig. f/Elec. Drive
1	1018434-330	Tube Housing (with Head Plate) (30' Ig.) (Mayrath)	34	5227A1	Clips f/Drive Shaft Cover
2	1215D	Head Flight 10'-10 1/2" Ig.	35	1018386	Head Cover Weldment
3	1232D	Intermediate Flight 9'-9 3/4" Ig.	36	1018533	Roller Chain Double #100 - 34 Pitch
4	1231D	Lower Flight 10'-6" Ig.	37	1013833	Sprocket (Double) #100 - 15 Tooth 2" Bore
5	1001041	Undercarriage Frame	38	1013834	Sprocket (Double) #100 24 Tooth 2" Bore
6	6332A1	Intake Guard Weldment	39	1018516	Head Stub Shaft
7	54339	Hitch Pipe	40	2214C	Bearing w/Lock Collar 2" Bore
8	5931A1	Half Band (3/16" Thick)	41	1018305	Head Plate (Welded to Auger Housing)
9	1264D	Internal Bearing Hanger w/Bronze Bushing	43	1018422	Head Drive Shaft
--	1254D	2" I.D. Bronze Bushing	45	4050A	Square Key 1/2" x 2" Ig.
10	1274D	Flight Connecting Stub	46	1018682	Roll Pin 7/16" x 4" Ig.
11	3029A2	Drive Shaft Bearing Retainer	47	1018508	Drive Shaft Cover Bracket (not shown)
12	3027A11	1 1/4" I.D. Drive Shaft Bearing w/Lock Collar	48	1007612	Gearbox to Drive Shaft Cover Bracket
13	1007611	Gearbox Mount	49	1259D	Intake Stub
14	5271A1	Half Band f/Gearbox Mount	50	8387D	Lower Undercarriage Clamp
15	6857A1	Band-on Winch Mount	51	1263D	Inspection Hole Cover
16	5271A1	Half Band f/Winch Mount	52	1260D	Inspection Hole Half Band
17	8340C	1/4" x 44' Ig. Winch Cable	53	862113	PTO Driveline to Gearbox Shield
18	6369C	1/4" Cable Clamp	54	50182A1	Upper Undercarriage Stop
19	1006197	Cable Pulley Assembly	55	6363D	15" x 4.5 KB 4-Bolt Wheel
	3223A1	1/4" Cable Pulley			
	5120A1	Pulley Clevis			
	50079A1	Bushing for 1/4" Cable Pulley			
21	1007600	Middle Drive Shaft 1 1/4" x 239 3/4" Ig.			
22	1007599	Drive Shaft Coupler 1 1/4" x 1 1/4"			
23	8371C	Square Key 1/4" x 1 1/2" Ig.			
24	1007596	Drive Shaft Extension f/PTO Drive f/PTO Drive 1 1/4" x 51" Ig.			
25	6144A1	Band-on Bearing Stand			
26	5269A1	Half Band f/Band-on Bearing Stand			
27	6836A1	PTO Driveline Transport Bracket			
28	5269A1	Half Band f/PTO Transport Bracket			

ELECTRIC DRIVE COMPONENTS

REF. NO.	PART NO.	DESCRIPTION
1	1006130-1	Gearbox (See below for parts breakdown)
2	1007611	Gearbox Mount
3	5271A1	Half Band f/Gearbox Mount
4	1007612	Drive Shaft Cover Bracket
5	1007599	Drive Shaft to Gearbox Coupler (1 1/4" x 1 1/4")
6	8371C	Square Key 1/4" x 1 1/2"
7	1007603	Motor Mount Frame
8	5931A1	Half Band for Motor Mount Frame
9	1002774	Belt Guard Mounting Bracket
10	1002748	Belt Guard
11	40154	Aluminum Sheave 3B 12" - 1 1/4" Bore
12	40120	Belt B-57
13	4046A1	Square Key 1/4" x 3" lg.

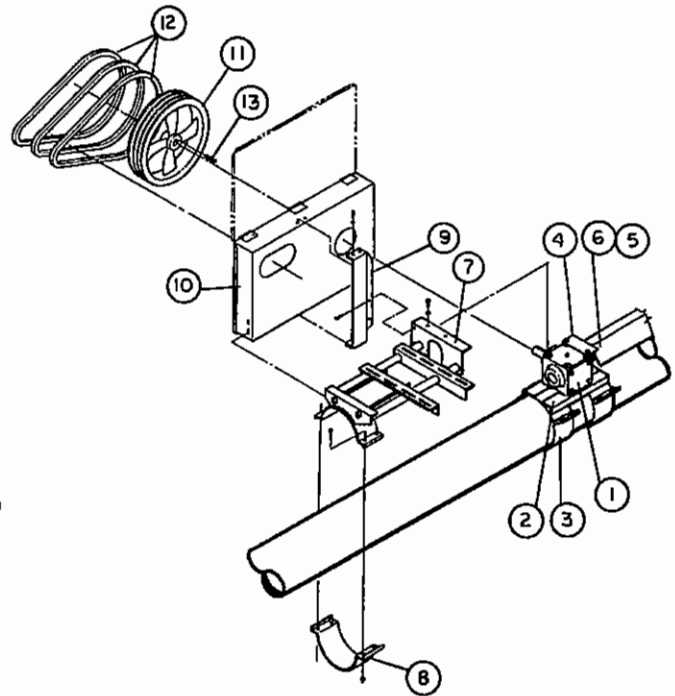

A GEARBOX COMPONENTS FOR GEARBOX 1006130-1

1 1/4" DIA. INPUT SHAFT - 1 1/4" DIA. OUTPUT SHAFT
 3/8" MOUNTING HOLES - 4" SQ. MOUNTING PATTERN
 RATIO 1 TO 1

REF. NO.	QTY. REQ'D.	PART NO.	DESCRIPTION
1	1	1023572	Case
2	1	1023573	End Cap
3	1	1023574	Large Cover
4	4	3079R1	Brg. Cone (LM57048)
5	4	3148R1	Brg. Cup (LM67010)
6	4	003538	Snap Ring
8	2	020153	Square Key 1/4" x 7/8" lg.
9	3	1023527	Spacer.
10	1	1023278	Seal (Nat. # 471808).
11	1	1012279	Seal (Nat. # 470163)
12	4	33060	3/8" x 1" NC Capscrew
13	4	D1150	3/8" Lockwasher
14	1	020009	1/4" Pipe Plug
15	1	1023282	O-Ring (3.15" O.D.)
16	2	1023287	Gear 90° Bevel - 17 tooth
17	1	1023575	Input Shaft
18	1	1023576	Output Shaft
19	A/R	1023288	Shim Kit
20	1	1023577	Small Cover
21	1	1023578	Gasket Cover
22	1	035916	1/4" Vented Plug

This gearbox is purchased from Weasler.
 The word "CHINA" will be inscribed on the housing

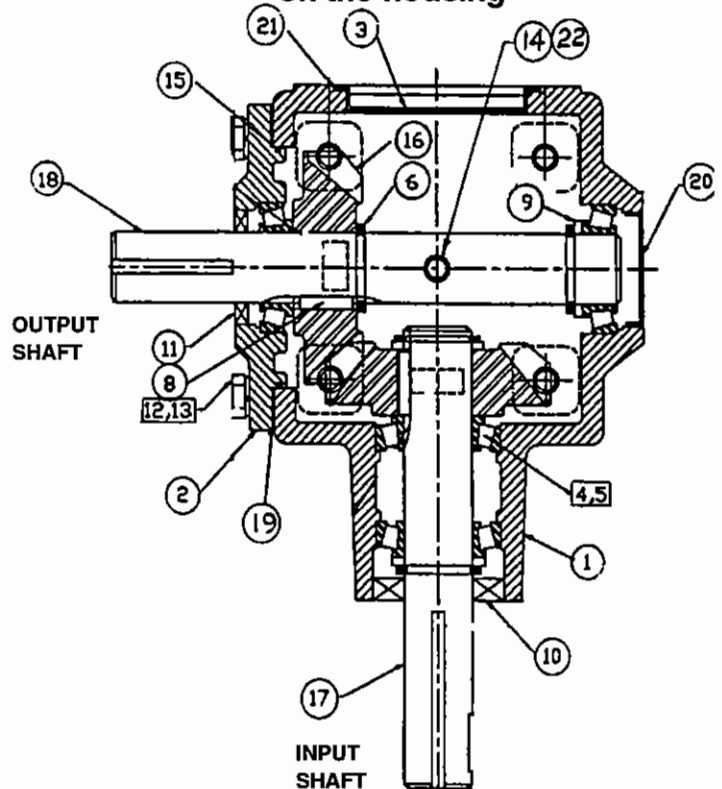

B SPINDLE & HUB ASSEMBLIES

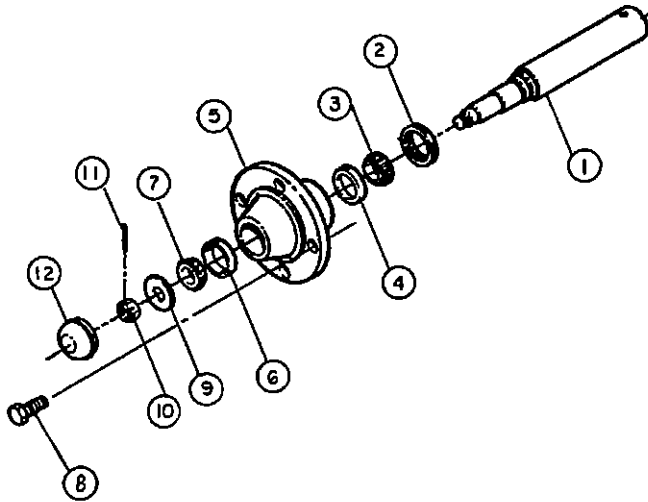

REF NO.	DESCRIPTION	PART NO.
-	Spindle & Hub Assy.	1001563
1	Spindle (2 1/6" x 10")	1001002
2	Grease Seal	106245
3	Inner Cone (Timken No.)	3079R1 (LM67048)
4	Inner Cup (Timken No.)	3148R1 (LM67010)
5	Hub w/cups	90174
6	Outer Cup (Timken No.)	40552 (LM11910)
7	Outer Cone (Timken No.)	40551 (LM11949)
8	Lug Bolt	106241
9	Washer	106252
10	Slotted Hex Nut	106250 (5/8")
11	Cotter Pin	D1146 (5/32" x 1 1/4")
12	Hub Cap	106244

C WINCH - BRAKE TYPE

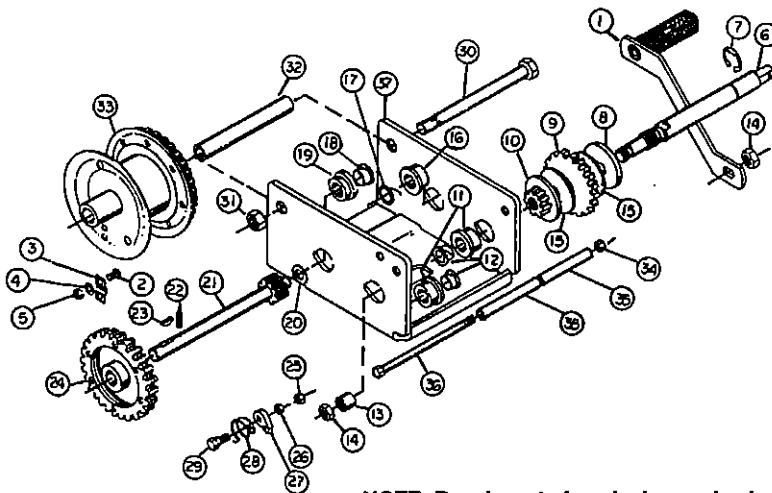

NOTE: Repair parts for winch can also be purchased directly from:
Fulton Manufacturing Corp.
 P.O. Box 19903
 Milwaukee, WI 53219

PARTS LIST FOR FULTON MODEL NO. K2550 WINCH COMPLETE PART NO. 40301

REF NO.	DESCRIPTION	HUTCHINSON PART NO.	FULTON PART NO.
1	Handle	41595	2461S01
2	Bolt	Cable Keeper	Cable Keeper
3	Cable Clamp	Kit	Kit
4	Lockwasher	41600	5621S01
5	Nut		
6	Input Shaft		
7	Retaining Ring		
8	Brake Disc	Input Shaft	Input Shaft
9	Ratchet Gear	Kit	Kit
10	Pinion Gear	41598	1565S01
11	Bushing		
12	Insert		
13	Spacer		
14	Nut		
15	Friction Disc	41601	Kit 1578S00
16	Bushing		
17	Insert		
18	Insert		
19	Bushing	Intermediate	Intermediate
20	Washer	Shaft	Shaft
21	Intermediate Shaft	Kit	Kit
22	Roll Pin	41599	1569S01
23	Woodruff Key		
24	Gear		
25	Nut		
26	Spacer	Ratchet Kit	Ratchet Kit
27	Ratchet Pawl	40836	6730S00
28	Spring		
29	Shoulder Bolt		
30	Drum Bolt T-Grade 5	*	*
31	Locknut	*	*
32	Drum Spacer	**	**
33	Drum Assembly	**	**
34	Locknut	*	*
35	Frame Spacer	**	**
36	Bolt	*	*
37	Frame	**	**

*Indicates standard hardware items - purchase locally.

** These items are not available as separate parts because of the precision assembly required.

If these parts require replacement, a new winch unit is recommended.

D PTO DRIVELINE

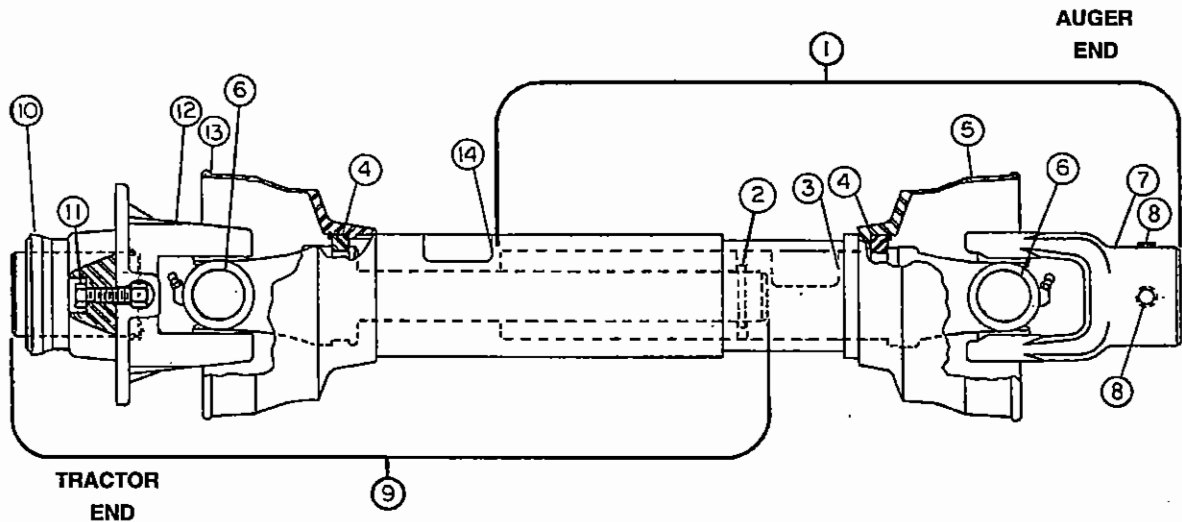

NOTE: Repair parts for PTO drivelines can also be purchased directly from:

Weasler Engineering, Inc.
 P.O. Box 558
 West Bend, WI 53095

U-JOINT TYPE - 14R
AUGER END 1 1/4" BORE
WITH 1/4" KEYSEAT
TRACTOR END 1 3/8" - 6B SPLINE
WITH SHEAR BOLT

REF. NO.	DESCRIPTION	HUTCHINSON	WEASLER
		PART NO.	PART NO.
--	PTO Driveline Complete	1002172	232-16106
1	Joint & Tube Half Assembly with Guard (Auger End)	1015285	92-16106
2	Roll Pin 1/4" x 1" long	1003691	11-10454
3	Inner Safety Sign	13-10022	13-10022
4	Shield Nylon Bearing Kit	1010565	19-11104
5	Inner Guard (Includes Ref. No. 4)	1006478	96-16106
6	U-Joint Cross Repair Kit	40524	03-10134
7	End Yoke	1003683	14011-1117
8	.375 - 16 x .38 long Setscrew	33170	N/A
9	Joint & Shaft Half Assembly with Guard (Tractor End)	1015286	93-16106
10	Spring Lock Flange Repair Kit	1003674	26-10133
11	Shear Bolt & Nut Kit (See Note)	1004778	---
12	Yoke & Ball Shear Assembly	1006480	26-11670
13	Outer Guard (Includes Ref. No. 4)	1006481	97-16106
14	Outer Safety Sign	13-10021	13-10021

Note: Shear Bolt Kit includes (6) 5/16" - 18 x 1" long Grade 5 hex head bolts and locknuts.



Hutchinson|Mayrath|TerraTrack

A Division of GLOBAL Industries, Inc.

P.O. Box 629 514 W. Crawford Clay Center, KS 67432
Phone 785-632-2161 1-800-523-6993 FAX 785-632-5964