

8" IN-LINE / MID-DRIVE PORTABLE AUGER

OWNER'S & OPERATOR'S MANUAL

Effective February 16, 2005

Publication No. 1012488

THIS MANUAL IS FOR UNITS WITH SERIAL NUMBERS OF 912425 OR HIGHER.



Hutchinson/Mayrath

A Division of **GLOBAL** Industries, Inc.

P.O. Box 629 • 514 W. Crawford • Clay Center, KS 67432
Phone 785-632-2161 • 1-800-523-6993 • FAX 785-632-5964



Hutchinson/Mayrath

A Division of **GLOBAL Industries, Inc.**

POLICIES AND PROCEDURES

- PRICES:** Prices in effect at time of shipment will apply. Prices are subject to change without notice. All prices are F.O.B. Clay Center, Kansas. Orders shipped from locations other than Clay Center, Kansas will be subject to additional charges, such as back freight and/or additional freight.
- SERVICE CHARGE:** A service charge will be assessed on all past due balances as permitted by state law not to exceed 1-1/2% per month.
- MINIMUM ORDER:** Processing and handling costs necessitate a minimum charge of \$15.00 net on all orders.
- BACK ORDERS:** Back orders will be shipped as they become available. Contact Hutchinson/Mayrath Customer Service for alternative shipping options or if cancellation is desired.
- DAMAGED GOODS:** It is the consignee's responsibility to check all shipments thoroughly upon receipt of goods. If any damage is discovered, it must be noted on the freight bill of lading before signing. The consignee must make necessary claims against the respective freight line. All damage claims must be submitted within 30 days of delivery receipt.
- SHORTAGES:** All shortages must be noted at time of delivery receipt. Shortages must be noted on the freight bill of lading before signing. Hutchinson/Mayrath must be advised of all concealed shortages upon discovery. Once notified of concealed shortages Hutchinson/Mayrath will advise corrective action to be taken.
- RETURN OF GOODS:** All returns must be approved by Hutchinson/Mayrath prior to shipment. All return requests will be issued a return authorization number. **NO RETURNS WILL BE ACCEPTED WITHOUT A RETURN AUTHORIZATION NUMBER AND PRIOR AUTHORIZATION FROM THE FACTORY.** All returns must be shipped prepaid. A 15% restocking charge will be applied to all returned merchandise. Custom Products may not be returned for credit. Only current products in new and salable condition may be returned. No safety devices may be returned for credit.
- MODIFICATIONS:** It is the policy of Hutchinson/Mayrath to improve its product whenever possible and practical to do so. We reserve the right to make changes, improvements and modifications at any time without incurring the obligation to make such changes, improvements and modifications on any equipment sold previously.
- LIMITED WARRANTY:**
- (a) For a period of (1) year after receipt of goods by the original consumer buyer, Hutchinson/Mayrath will supply free of charge replacement parts for parts that prove defective in workmanship or material. Defective parts must be returned freight prepaid to a specified Hutchinson/Mayrath location. Only Hutchinson/Mayrath original repair parts may be used for warranty repairs.
 - (b) This limited warranty does not extend to parts designed to wear in normal operation and be replaced periodically; or to damage caused by negligence, accident, abuse or improper installation or operation.
 - (c) **GOODS NOT MANUFACTURED BY HUTCHINSON/MAYRATH CARRY ONLY THE MANUFACTURER'S WARRANTY.**
 - (d) **THIS UNDERTAKING IS IN LIEU OF ALL OTHER WARRANTIES, EXPRESSED OR IMPLIED, INCLUDING MERCHANTABILITY AND FITNESS FOR A PARTICULAR PURPOSE.**

FAILURE TO FOLLOW THE INSTRUCTIONS CONTAINED IN THE OWNER'S & OPERATOR'S MANUALS AND THE ITEMS LISTED BELOW WILL RESULT IN THE VOIDING OF THIS LIMITED WARRANTY.

- 1) Improper assembly, including failure to properly install all safety equipment.
- 2) Improper installation (power & wiring included).
- 3) Unauthorized alterations of goods.
- 4) Goods operated when obviously in need of repair.
- 5) Use of unauthorized repair parts.
- 6) Irresponsible operation.
- 7) Used to handle materials other than free flowing, non-abrasive and dry materials, as intended.
- 8) Damaged through abusive use or accident.

- LIMITATION OF LIABILITY:** BUYER AGREES THAT IN NO EVENT SHALL HUTCHINSON/MAYRATH HAVE LIABILITY FOR DIRECT DAMAGES IN EXCESS OF THE CONTRACT PRICE OF THE GOODS IN RESPECT OF WHICH CLAIM IS MADE. BUYER FURTHER AGREES THAT IN NO EVENT SHALL HUTCHINSON/MAYRATH ON ANY CLAIM OF ANY KIND HAVE LIABILITY FOR LOSS OF USE, LOSS OF PROFITS, OR FOR ANY INDIRECT, INCIDENTAL OR CONSEQUENTIAL DAMAGES.

GENERAL SAFETY STATEMENT

This manual was written with the safety of the operator and others who work with the equipment as our prime concern. The instructions presented will help the reader learn SAFE day to day work practices. We want you as our partner in safety.

It is your responsibility as an owner, operator or supervisor to know what specific safety requirements and precautions exist and to make these known to all other personnel working with the equipment or in the area, so that they too may safely perform their duties and avoid any potentially hazardous situations.

Please remember safety equipment provides important protection for persons around a grain handling system that is in operation. Be sure that ALL safety shields and protection devices are installed and properly maintained. If any shields or guards are damaged or missing, contact your dealer to obtain the correct items.

Avoid any alterations of the equipment. Such alterations may create a dangerous situation where serious injury or death may occur.

SAFETY ALERT SYMBOL

The symbol shown below is used to call your attention to instructions concerning your personal safety. Watch this symbol - it points out important safety precautions. It means "ATTENTION! Become alert! Your personal safety is involved!" Read the message that follows and be alert to the possibility of personal injury or death.



BE ALERT! YOUR SAFETY IS INVOLVED.



WARNING

Anyone who will operate or work around this machine shall first read this manual! This manual must be delivered with the equipment to its owner. Failure to read this manual and its safety instructions is a misuse of the equipment.

TABLE OF CONTENTS

General Safety Statements	1
Safety Symbol	1
Operator Qualifications	3
Sign-off Sheet	3
Machine Inspection	3
Tractor Requirements	4
HITCHING TO TRACTOR	4
TRANSPORTING AUGER	5
PLACEMENT OF AUGER	6-7
UNHITCHING	7
DESIGNATED WORK AREA	8
OPERATING PROCEDURES	9-13
Break-in	9
PTO Drive Information	9-10
Electric Motor Drive Information	11-12
Operating Capacities	12
Shutdown	12
Lockout	13
RELOCATION OF AUGER	13
LUBRICATION AND MAINTENANCE	14-16
PTO Driveline	14
Bearing	14
Hydraulic Cylinder	15
Hydraulic Hose	15
Gearbox	15
Belt Adjustment	15
Winch	16
TROUBLE SHOOTING	17
ASSEMBLY INSTRUCTIONS	18-45
PTO DRIVE CHANGEOVER INSTRUCTIONS	45
DRIVE HOUSING DISASSEMBLY INSTRUCTIONS	46
PARTS LIST	P-1 thru P-17

SERIAL NUMBER

To ensure efficient and prompt service, please furnish us with the model and serial number of your auger in all correspondence or other contact. The serial plate is located on the left side of the drive housing on the tube.

RIGHT AND LEFT DESIGNATION

When determining which is the left or right hand side of the unit, it is as if a person were standing at the intake end and looking toward the discharge end.

OPERATOR QUALIFICATIONS

Operation of this portable auger shall be limited to competent and experienced persons. In addition, anyone who will operate or work around a portable auger must use good common sense. In order to be qualified, they must also know and meet all other requirements, such as:

1. Some regulations specify that no one under the age of 16 may operate power machinery. This includes portable augers. It is your responsibility to know what these regulations are in your own area or situation.
2. Current OSHA regulations state in part: "At the time of initial assignment and at least annually thereafter, the employer shall instruct every employee in the safe operation and servicing of all equipment with which the employee is, or will be involved."*
3. Unqualified persons are to stay out of the work area as shown in the work area diagrams. See Page 8.
4. A person who has not read and understood all operating and safety instruction is not qualified to operate the machine.

*Federal Occupational Safety & Health Standards for Agriculture Subpart D, Section 1928.57 (a)(6).

SIGN OFF SHEET

As a requirement of OSHA it is necessary for the employer to train the employee in the safe operation and safety procedures with this auger. We include this sign off sheet for your convenience and personal record keeping.

DATE	EMPLOYER SIGNATURE	EMPLOYEE SIGNATURE

MACHINE INSPECTION

After delivery of your new auger and/or completion of assembly and before each use, inspection of the machine is mandatory. Use the assembly instructions in this manual as a reference to determine that the auger is assembled properly. This inspection should include, but not be limited to:

1. Check to see that all guards listed in the assembly instructions are in place, secured and functional. The shields on the input drive line must rotate easily.
2. Check all safety signs and replace any that are worn, missing or illegible. The safety signs are listed on page P-1 and P-2. Safety signs may be obtained from your dealer or ordered from the factory.
3. On Manual Lift Models - Check winch and cable for security and operation. There should be at least three complete wraps of cable around winch drum in full down position. Cable anchor on winch drum must be tight.
On Hydraulic Lift Models - Check the hydraulic hose and all the fitting connections to see if they are tight and not leaking hydraulic oil.
4. Are all fasteners tight?
5. Are belts properly adjusted? (See Maintenance Section.)
6. Check oil level in gearbox. (See Maintenance Section.)
7. Check that clean-out door on underside of bell housing is closed.

Obtain any needed replacement parts from your dealer and install before using the machine.

TRACTOR REQUIREMENTS

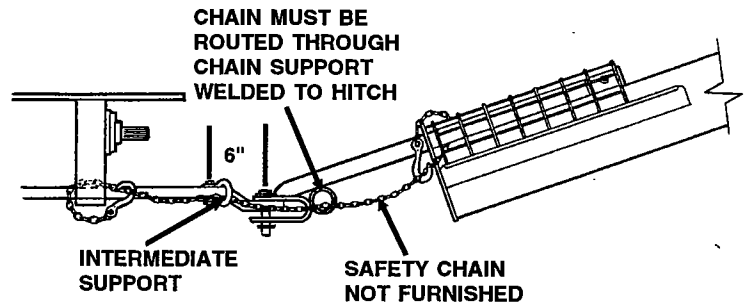
This 8" auger was designed to use a tractor with the following specifications:

1. 540 RPM Power Take Off
2. One hydraulic control circuit for lifting the main auger. (See chart for minimum pressure.)

	8" x 32'	8" x 42'	8" x 52'	8" x 62'	8" x 72'
Tractor Hydraulic for Auger Lift	N/A	N/A	1200	1500	1500
Approx. PTO Horsepower	30	30	40	50	60

HITCHING TO TRACTOR INSTRUCTIONS

1. Never stand between tractor and machine when hitching unless all controls are in neutral and the brakes locked.
2. Never raise the intake end higher than is necessary to attach to the tractor. Weight transfers rapidly to the head end when the intake is raised. **NOTE:** Empty machine before moving to prevent upending. It may be necessary when lifting the intake for hitching or unhitching to use assistance in the lifting process. The intake weight may be greater than what one person can comfortably lift. Use of a portable jack is recommended when necessary. A recommended lifting point is where the hitch emerges from the intake. Be sure the auger wheels are chocked when lifting with a portable jack.
3. Pin the auger hitch to the tractor drawbar. Make certain the hitch is securely attached.
4. An auxiliary attachment system (safety chain) is required to retain the connection between towing and towed machines in the event of separation of the primary attachment system. **NOTE:** The safety chain is not furnished with the auger.

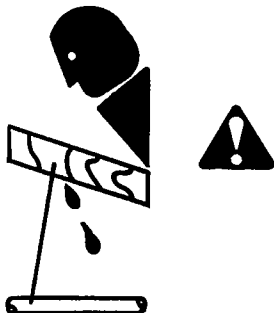


The safety chain should be routed through the intake safety screen and around the hitch pipe. Route the chain through the support ring on the hitch pipe then anchor it to the tractor.

A clevis or intermediate chain support should be fastened to the tractor drawbar no farther than 6" from the hitch pin.

5. On Hydraulic Lift Models - connect the hydraulic hose to tractor.

WARNING: Keep all hydraulic lines away from moving parts.



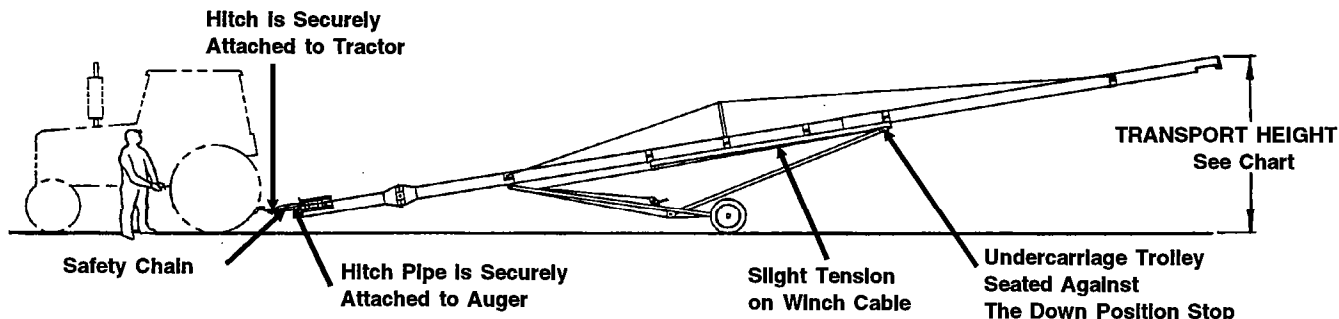
CAUTION: Do not connect or disconnect hydraulic components when there is pressure within the system. Hydraulic systems are highly pressurized. Escaping hydraulic oil, even an invisible pinhole leak, can penetrate body tissues and cause serious injury. Use a piece of wood or cardboard when looking for leaks. Never use the hands or other parts of the body. When reassembling, make absolutely certain that all connections are tight. If injured by hydraulic oil escaping under pressure, see a doctor immediately. Serious infection or reaction may occur if medical attention is not received at once. Keep all hydraulic lines away from moving parts.

TRANSPORTING THE AUGER

Move the auger with a tractor to or from the work area. A pick-up truck or other suitable vehicle may be used for transporting the auger over greater distances. Comply with your state and local regulations governing marking, towing and maximum width. Observe safe driving and operation practices.

Follow these steps when transporting auger:

1. Always transport the auger in the full-down position.
2. On Manual Lift Models - Be sure there is slight tension on the winch cable (shown below).
3. On Hydraulic Lift Models - The hydraulic shut-off valve must be closed.
4. Hitch should be securely fastened to transport vehicle and safety chain properly attached.



Moving the portable auger requires careful planning. Know the transport height of the auger before moving it. Plan your route to avoid overhead obstructions and power lines.

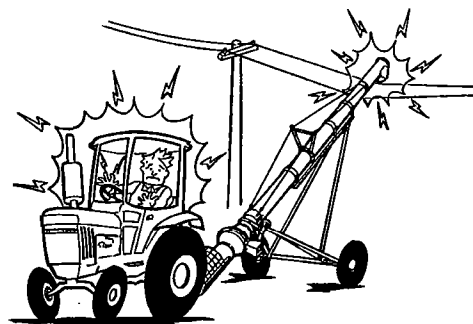
TRANSPORT HEIGHT*

Model Length	32'	42'	52'	62'	72'
Manual Lift Model	8'-10" to 9'-10"	9'-10" to 10'-10"	10'-10" to 11'-10"	12'-6" to 13'-6"	12'-10" to 13'-10"
Hydraulic Lift Model	N/A	N/A	11'-9" to 12'-9"	12'-6" to 13'-6"	12'-6" to 13'-6"

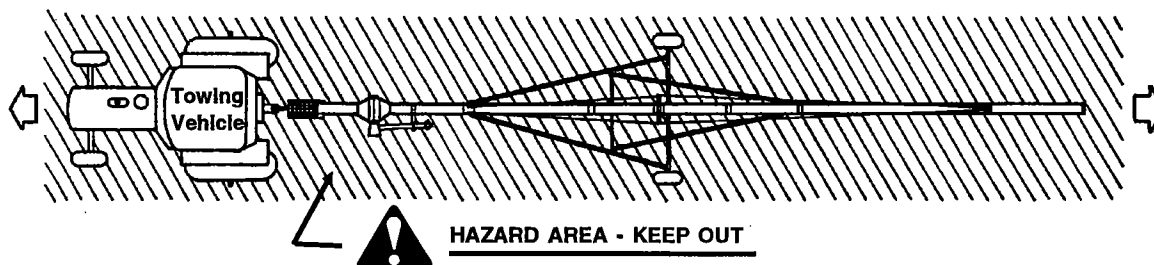
***IMPORTANT:** Overall transport height is with the auger fully lowered and the intake on the ground. When the auger is attached to a towing vehicle, these heights will be approximately 12" less.



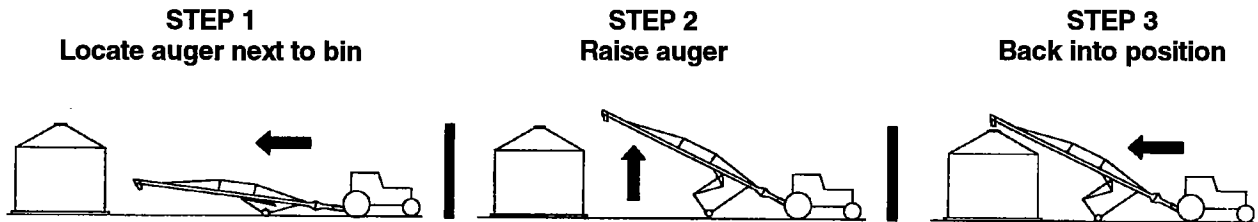
DANGER: Be alert to overhead obstructions and electrical wires. Failure to do so may result in electrocution. Lower auger well below level of power lines before moving. Maintain at least ten (10) feet of clearance. Electrocution can occur without direct contact. See above chart showing the height of each portable auger in the transport position to determine the height of the auger.



Before moving the auger, the operator should make sure all personnel are clear of the Moving Auger Hazard Area as shown in the following diagram. Never allow persons to stand underneath or ride on the auger when it is being transported.



PLACEMENT OF AUGER



Step 1

Move auger slowly toward working position with a tractor - NOT BY HAND. Locate the auger on level ground as close as possible to the bin or other structure. Leave adequate room for loaded vehicles to reach the auger intake area conveniently. The wheels must be allowed to roll freely when raising. Be sure the area is clear of any obstructions. On Hydraulic Lift Undercarriage Models - Open the hydraulic shut-off valve.



Make certain everyone is clear of the work area when moving the auger. To prevent tip-over when backing, avoid rolling over any obstructions. Also avoid moving the auger at right angles to a slope. If the auger must set on a slope, approach the bin uphill.

Make sure entire area above auger and in line of travel is clear of overhead obstructions and electrical wires. Failure to do so may result in electrocution. Maintain at least ten (10) feet of clearance. Electrocution can occur without direct contact.

Step 2

Raise the auger only high enough to allow minimum clearance above the bin.

On Hydraulic Lift Undercarriage Models - Raise or lower the auger by using the hydraulic circuit control lever on the tractor.

On Manual Lift Undercarriage Models - To raise the auger, turn the winch handle clockwise (pulling cable onto winch drum). There should be a clicking sound. Observe the cable as it is winding onto the winch drum. The cable should roll up on the drum evenly; avoid cable build-up on one side of the drum.

NOTE: The winch is equipped with a brake that is actuated by turning the handle. The brake is designed to hold the load whenever the handle is released.

NOTE: For additional winch instructions, see page 16.



Keep hands away from winch drum during operation.

Don't allow auger to become hung up.

Don't continue to crank the winch after the undercarriage slide reaches the stop.

PLACEMENT OF AUGER

Step 3

Back auger slowly into working position with a tractor. **NEVER ATTEMPT TO MOVE AUGER BY HAND. USE A VEHICLE. DO NOT ATTEMPT TO INCREASE AUGER HEIGHT BY POSITIONING WHEELS ON LUMBER, BLOCKS OR BY OTHER MEANS.**

1. Lower the auger until the auger discharge is directly over the bin opening. Consider that the discharge end will lower a few inches as the auger fills with grain.

NOTE: When discharging into a grain spreader, maintain at least 12" of space between the auger discharge and the spreader.

On Manual Lift Undercarriage Models - lower the auger, turn the winch handle counter-clockwise; there will be no clicking sound. To stop while lowering the auger, turn the handle clockwise until you hear two clicks to lock brake. (About a 6" movement of the handle.) NOTE: For additional winch instructions, see page 16.

On Hydraulic Lift Undercarriage Models - lower the auger by using the hydraulic circuit control lever on the tractor.

2. Once the auger is in place, put the tractor in park.
3. Follow unhitching instructions below.
4. Remove bolt from hitch pipe and remove hitch from auger intake.
5. If a hopper attachment is to be used, install it at this time.
6. Anchor the auger at the intake end and/or support it at the discharge end to prevent tipping from occurring when weight transfers to the top end as the auger empties. It is a good practice to tie the discharge end of the auger to the bin or storage structure to prevent possible wind damage. Remember to untie the auger before attempting to move it.

UN-HITCHING

Follow these steps to unhitch the auger:

NOTE: When the tractor is to be disconnected from an auger in the raised position, anchor the discharge end of the auger to the bin or structure to prevent possible wind damage.

- A. The hydraulic shut-off valve must be closed to prevent possible leakdown.*
- B. Relieve tractor internal hydraulic pressure. Then disconnect the hydraulic hose from the tractor.*
- C. The auger wheels should be chocked to prevent the auger from rolling.
- D. Remove safety chain and hitch pin. Disconnect the tractor from the auger.
- E. Lower the intake to the ground.



Never raise the intake end higher than necessary for hitching/unhitching. Weight transfers rapidly to the head end when the intake is lifted, especially when the auger is in a raised position. Never stand between tractor and auger when unhitching unless all controls are in neutral and the brakes locked.

* These steps apply to Hydraulic Lift Undercarriage Models only.

DESIGNATED WORK AREA

Before starting the auger, a designated work area should be established and properly marked. The following diagrams show the manufacturers recommended work areas. These areas shall be marked off with colored nylon or plastic rope hung as portable barriers to define the boundaries.

RULES FOR SAFE WORK AREA

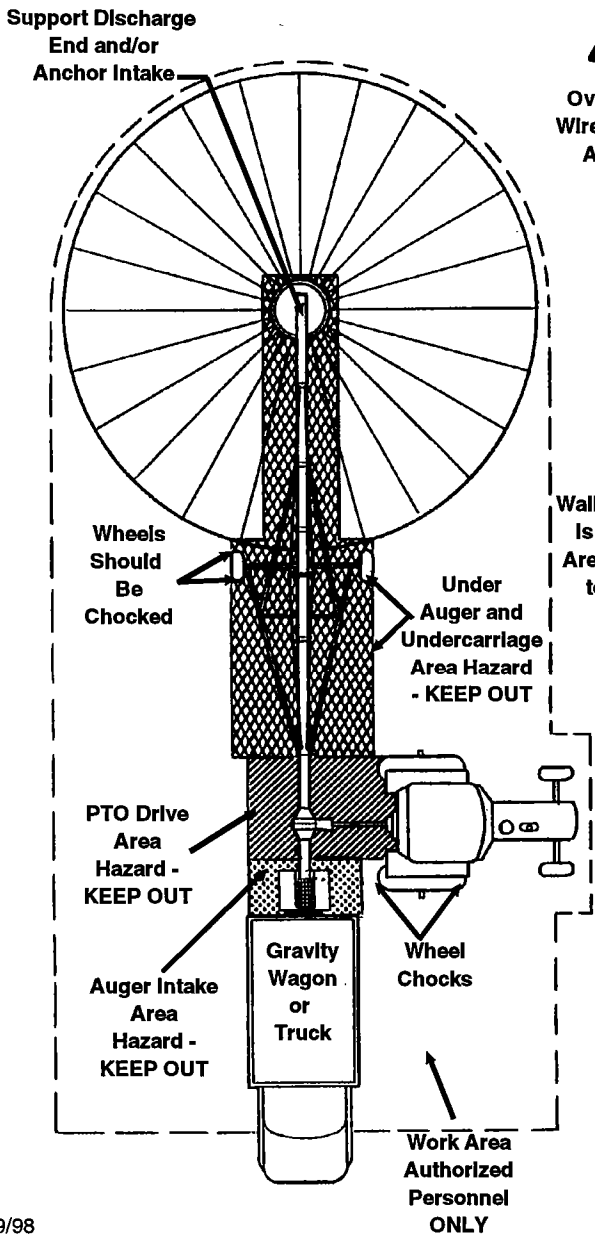
Under no circumstances should persons not involved in the operation be allowed to trespass into the work area.



It shall be the duty of all operators to see that children and/or other persons stay out of the work areas! Trespass into the work area by anyone not involved in the actual operation, or trespass into a hazard area by anyone, shall result in an immediate shut down by the operator.

It shall be the responsibility of all operators to see that the work area has secure footing, is orderly, clean and free of all tools and debris and which might cause accidental tripping and/or falling.

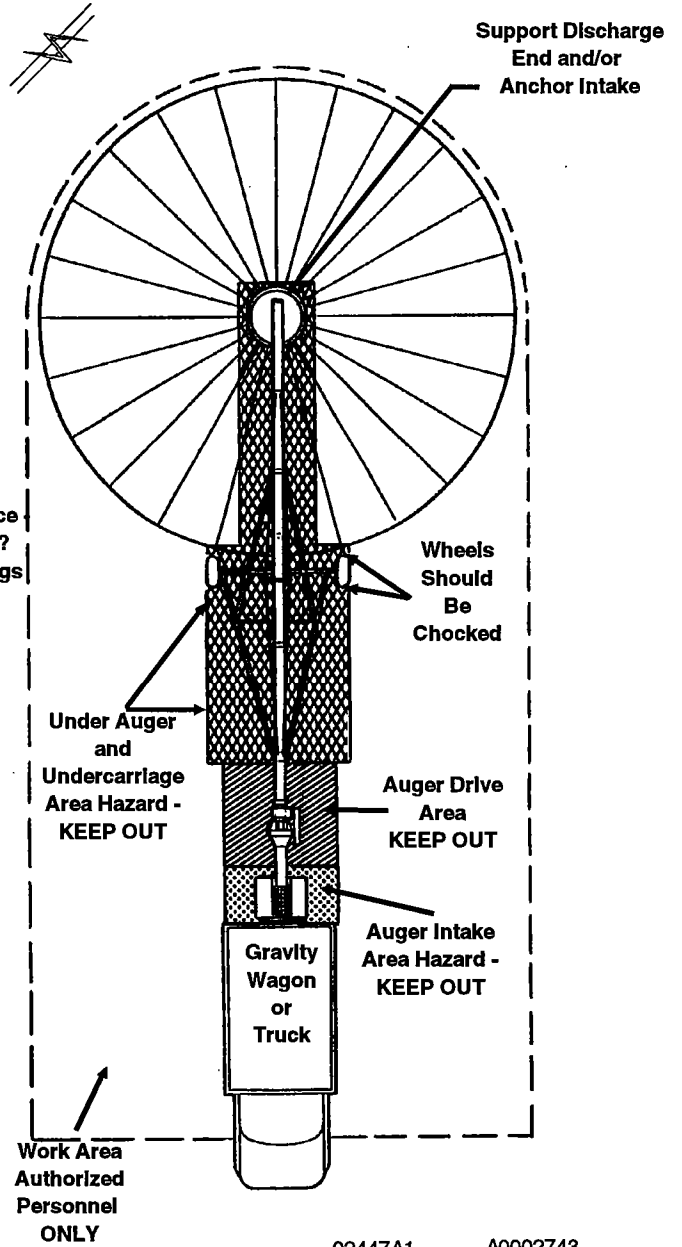
PTO DRIVE UNITS



Overhead Wires KEEP AWAY

Walking Surface Is it slippery? Are there things to trip you?

ELECTRIC DRIVE UNITS



OPERATING PROCEDURES

Our augers are well made and we are proud of our line of equipment. We would like you, as our customer, to do your part in using caution and good judgement in using our equipment, as well as any other machinery.

It is important to be familiar with the following routine operation procedures before attempting start-up.

During the operation of your auger, one person shall be in a position to monitor the operation. Inspect the drive before adding power and know how to shut down in an emergency. (See page 12.) Visually inspect the auger periodically during operation. For efficient and safe operation, be aware of all the adjustments and checks which should be performed.

The operator shall have a full view of the auger work area and check that all personnel are clear of hazard areas before adding power.

Keep all safety shields and devices in place.



Keep hands, feet and clothing away from moving parts.

The operator shall be aware of any unusual vibrations, noises and the loosening of any fasteners.

Only use an agricultural tractor which meets the requirements listed on page 4.

The ideal operating speed for this 8" auger is 540 RPM. An acceptable range is 300 to 600 RPM. Running the auger at speeds higher than recommended causes excessive wear. Do not attempt full load operation at speeds below 300 RPM as high torque requirements may damage the auger.

Close clean-out door on underside of drive housing before operation. Close the drain hole cover on the intake guard.

Never operate the auger empty for any length of time as excessive wear will result. If at all possible, do not stop or start the auger under load, especially before the flight and tube become well polished, as this may cause the auger to "freeze-up". (See BREAK-IN INFORMATION.)

BREAK-IN INFORMATION

Any screw conveyor when it is new or after it sets idle for a season should go through a "break-in" period. DO NOT operate the auger empty. The auger should be run at partial capacity until several hundred bushels of grain have been augered to polish the flighting assembly and tube. Once this is accomplished, the auger can be run full.

PTO DRIVE INFORMATION

The PTO driveline furnished with the auger is equipped with a "spring-lock" coupler at the tractor end and will fit the standard 1 3/8" x 6 spline PTO output shaft from a tractor.

To attach the driveline to the tractor, compress the spring keeper on the driveline, slide end onto the tractor PTO until the keeper seats in the groove on the shaft. This will lock the PTO driveline onto the tractor PTO.

The PTO driveline is equipped with a shear bolt at the tractor connection. The shear bolt protects the auger from damage if the auger becomes plugged or subjected to high loads. Extra shear bolts are shipped with the auger in the instruction manual container. See page P-14 for replacement shear bolt information.

OPERATING PROCEDURES PTO DRIVE INFORMATION - CONT.

The PTO driveline is a pin stop type--that is the two telescoping sections will not separate. It is a good practice to operate the PTO driveline in as short a configuration as possible. Keep the PTO driveline in as straight a line as possible during operation. Align PTO driveline with tractor. When connecting tractor and auger, always make sure the tractor axle and side of auger are parallel. See Fig. A. If the tractor and auger are on unlevel ground or at different levels, place them so the center line of the tractor and the gearbox shaft are parallel. See Fig. B.

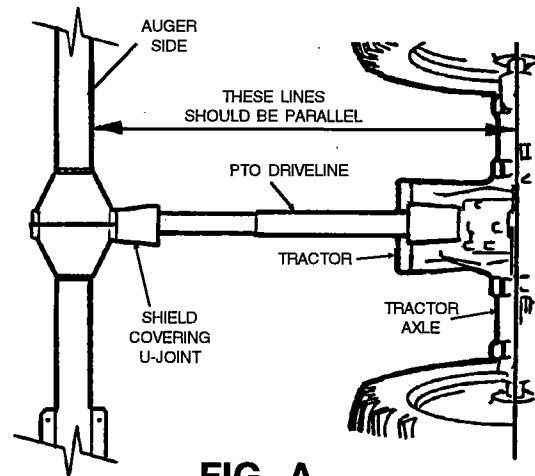


FIG. A

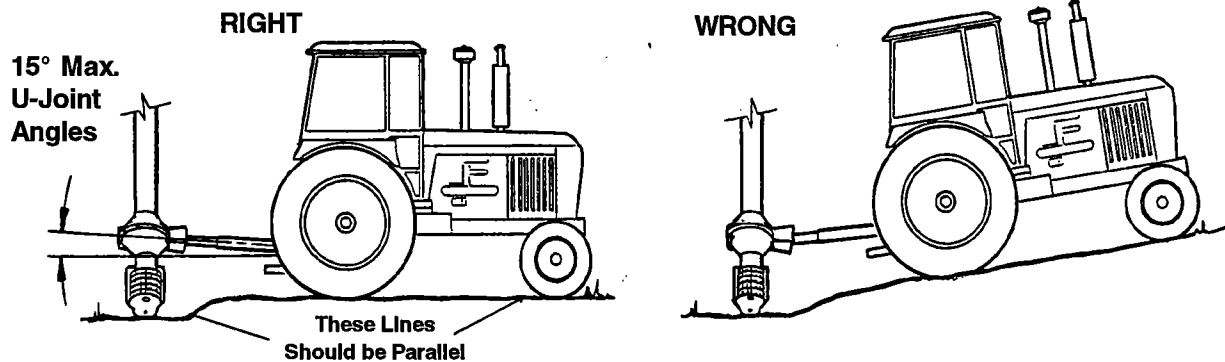


FIG. B

PTO DRIVE START-UP

CHECK THE FOLLOWING BEFORE ADDING POWER:

Before starting the tractor, be certain power to PTO is off.



Be certain the PTO driveline is securely attached to the auger and the tractor.

Use a PTO driveline with a rotating shield in good working order that can be turned freely on the shaft.

Stay out of designated hazard area of an operating PTO. Observe work area restriction. (See work area diagram on page 8.)

TO START AUGER:

Engage PTO at a slow RPM to minimize shock loads. Then work up RPM to recommended speed as listed on page 9. The gearbox input to output drive ratio is 1 to 1.

TO STOP AUGER:

1. Let auger empty of grain before stopping.
2. Disengage PTO and lockout.

NOTE: The standard direct PTO may be driven from either side (as explained in the PTO Drive Assembly Section).

Care should be taken when changing the drive from one side of the auger to the other side. To avoid dangerous situations, follow change over instructions on page 45.

OPERATING PROCEDURES - CONT.

TOP MOUNTED ELECTRIC MOTOR DRIVE INFORMATION

Always use a motor with required H.P. suggested in the charts below. Use a motor that operates at 1750 RPM. Electric motors and controls shall be installed by a qualified electrician and must meet the standards set by the National Electrical Code and all local and state codes. Reset and Motor Starting Controls may be mounted directly to the auger or in a nearby area, but they must be located so that the operator has full view of the entire operation from the control location.

A magnetic starter should be used to protect your motor when starting and stopping. It should stop the motor in case of power interruption, conductor fault, low voltage, circuit interruption, or motor overload. Then the motor must be restarted manually. Some motors have built-in thermal overload protection. If this type motor is used, use only one with manual reset.

Auger Size	BPH (Max.)	Auger Pulley	Motor Pulley (Not Included)	Auger Speed	H.P. Req'd.*
8" x 32'	3200	15" O.D.	5.0" O.D.	580 RPM	5 - 7 1/2
8" x 42'					7 1/2-10
8" x 52'					10
8" x 62'					15
8" x 72'					20
8" x 32'	2700	15" P.D.	4.5" O.D.	525 RPM	5 - 7 1/2
8" x 42'					7 1/2-10
8" x 52'					7 1/2-10
8" x 62'					10-15
8" x 72'					15-20
8" x 32'	2100	15" O.D.	4.0" O.D.	465 RPM	5 - 7 1/2
8" x 42'					7 1/2
8" x 52'					7 1/2-10
8" x 62'					10
8" x 72'					15
8" x 32'	1700	15" O.D.	3.5" O.D.	410 RPM	5
8" x 42'					7 1/2
8" x 52'					7 1/2-10
8" x 62'					10
8" x 72'					10-15

*For higher moisture grain (up to 25%) the next larger motor may be used as a maximum.

OPTIONAL 8" INLINE AUGER REDUCTION GEARBOX

This gearbox is designed with a reduction ratio of 1.35 to 1, to slow down the auger flight speed. It is important to match the auger speed to the capacity rate at which the auger will be fed. Select an auger speed that is high enough to keep grain clear of the intake. An auger speed that is too slow will allow the flighting to "load up", creating a high torque requirement to turn the auger flighting and likely causing damage to the auger components. Possible auger speeds for an electric driven auger using this reduction gearbox are as follows:

Auger Size	BPH (Max.)	Auger Pulley	Motor Pulley (Not Included)	Auger Speed	H.P. Req'd.*
8" x 32'	1400	15" O.D.	4.5" O.D.	389 RPM	5
8" x 42'					5 - 7 1/2
8" x 52'					7 1/2
8" x 62'					7 1/2-10
8" x 72'					10
8" x 32'	1200	15" O.D.	4.0" O.D.	346 RPM	5
8" x 42'					5 - 7 1/2
8" x 52'					7 1/2
8" x 62'					7 1/2
8" x 72'					10
8" x 32'	1000	15" O.D.	3.5" O.D.	302 RPM	3
8" x 42'					5
8" x 52'					5 - 7 1/2
8" x 62'					7 1/2
8" x 72'					7 1/2-10
8" x 32'	800	15" O.D.	3.0" O.D.	259 RPM	3
8" x 42'					3
8" x 52'					5 Max.
8" x 62'					5 Max.
8" x 72'					5 Max.

OPERATING PROCEDURES - CONT.

TOP MOUNTED ELECTRIC MOTOR DRIVE INFORMATION

NOTE: Motor Pulleys are not furnished with the auger.

The horsepower recommendations are for augering reasonably dry grain at varying angles. High moisture grain (above 15%) will require greater horsepower. Maximum possible capacity will be less with high moisture grain than with dry grain.



**Disconnect power before resetting motor overloads.
Make certain electric motors are grounded.**

ELECTRIC MOTOR DRIVE START UP

BEFORE ADDING POWER:

Check that belt guard is in place, secured and functional.

TO START AUGER

Start electric motor before conveying grain.

TO STOP AUGER

Let auger empty of grain before stopping.
Shut off electric motor and lockout.

OPERATING CAPACITIES

Capacities of screw conveyors or augers can vary greatly under diverse conditions. Different materials, moisture content, amounts of foreign matter, angle of operation, methods of feeding and speed all play a role in the performance of the auger. Roughly 3200 BPH will be achieved augering reasonably dry grain. Maximum possible capacity will be less with high moisture grain (above 15%) than with dry grain.

SHUTDOWN

A. NORMAL SHUTDOWN

Make certain that the auger is empty before stopping the unit. Before the operator leaves the work area, the power source shall be locked out. (See LOCKOUT).

B. INTERMITTENT OPERATION SHUTDOWN

When an auger is stopped and restarted under full load, it may result in damage to the auger.

Therefore, if intermittent operation is to be carried out, it is advisable to reduce the load level. When kept from absolute filling, auger start-up is easier and operation is more efficient.

C. EMERGENCY SHUTDOWN

Should the auger be immediately shut down under load, disconnect and lockout the power source. Clear as much grain from hopper and auger as you can. Never attempt to start when full. Use clean-out doors. When as much grain as possible has been cleared, reconnect power source and clear auger gradually.

NOTE: Starting the unit under load may result in damage to the auger. Such damage is considered abuse of the equipment.

OPERATING PROCEDURES - CONT.

LOCKOUT



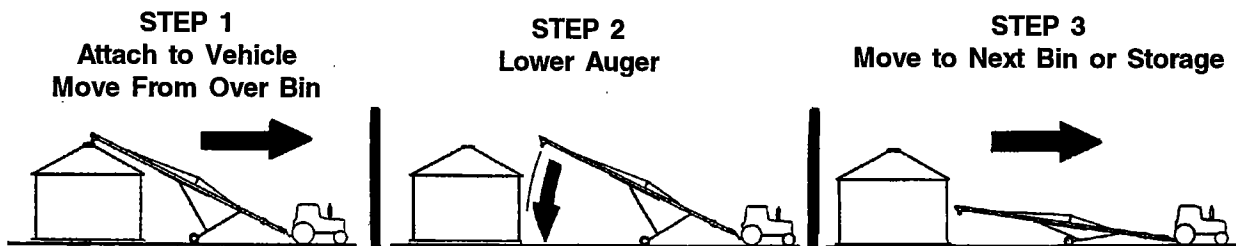
WARNING: If the operator must leave the work area, or whenever servicing or adjusting, the auger must be stopped and the power source turned off. Precaution should be made to prevent anyone from operating the auger when the operator is absent from the work area.

DIRECT PTO DRIVE: Remove ignition key or coil wire from power source. (If this is impossible, remove the PTO driveline from the work area.)

TOP MOUNTED ELECTRIC DRIVE: A main power disconnect switch capable of being locked only in the off position shall be provided.

RELOCATION OF AUGER

When grain conveying operation is completed, the auger should be moved away from the bin and lowered. The auger can then be moved to a different bin for more conveying operations or cleaned up and stored.



STEP 1

- A. Empty all grain from the auger. Clean up the area.
- B. Untie any anchors an/or remove all supports.
- C. Disconnect the power source.

Top Mounted Electric Drive - Unplug electric motor, wind up electric cables.

Direct PTO Drive - Disconnect PTO driveline from tractor and place in support provided for transporting.

NOTE: The bracket pin must be in place to hold the PTO driveline in the support during transporting.

- D. Install the hitch pipe.
- E. If auger is to be stored or unused for a time, open the drain hole cover on the intake guard.
- F. On Hydraulic Lift Undercarriage Models
Connect the hydraulic hose to the tractor and open hydraulic shut-off valve.
- G. Raise the auger so the discharge spout is clear of bin opening. (See Auger Raising Instructions on page 6 for Manual Lift Models.)
- H. Lift the auger intake and hitch to the tractor. (See Hitching Instructions on page 4.)
- I. Remove wheel chocks.
- J. Move auger slowly away from the bin with a tractor -- **NOT BY HAND.**

STEP 2

- A. Lower auger immediately after clear of bin or storage structure.
IMPORTANT: Lower the auger, even if relocating to a bin in the immediate area.

STEP 3

- A. Move the auger to next bin or the area where the auger is to be stored after use. We recommend that the auger be stored in the full down position with intake end anchored.
- B. On Hydraulic Lift Undercarriage Models:
Close hydraulic shut-off valve to prevent loss of hydraulic oil. Disconnect hydraulic hose from tractor.
- C. Unhitch auger from the tractor and lower auger intake to ground.
- D. Inspect the auger as outlined in the "Machine Inspection Section" on page 3. For storage the clean-out door on the underside of the bell housing should be left open to allow moisture out.

LUBRICATION & MAINTENANCE

For economical and efficient operation of your auger maintain regular and correct lubrication. Neglect leads to reduced efficiency, excessive wear and needless down time. Use the following schedule for best results.



Keep all safety shields and devices in place. Replace any that are damaged or missing. Shut off power and lockout drive to adjust, service or clean.

Any parts needing replacement should be replaced with parts of the same type and size. Do not modify or alter any of the auger components.

PTO DRIVELINE

Augers equipped with PTO driveline, should have the u-joints lubricated at approximately ten (10) hour intervals with SAE multipurpose type grease.



Be sure that PTO driveline shields turn freely on shaft.

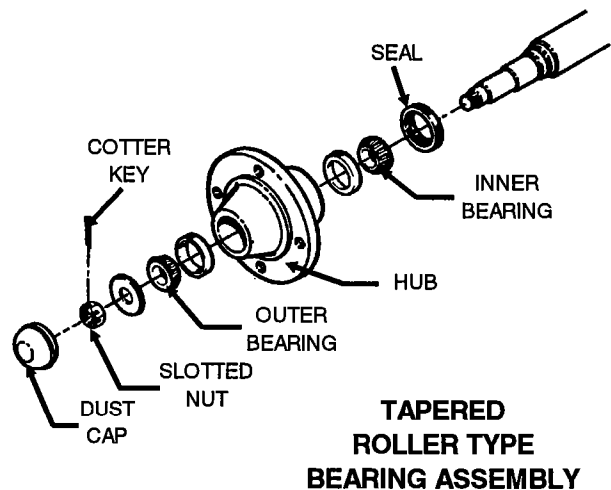
The PTO driveline is equipped with a shear bolt at the tractor connection. The shear bolt protects the auger from damage if the auger becomes plugged or subjected to high loads. It is important to use the correct replacement bolt of the proper size and strength to insure that the shear device will protect the auger and operator. Order replacement shear bolt, Part No. 33046 - 5/16" NC x 1" long grade 5 bolt. Extra shear bolts are provided with auger and are stored in the operator's manual container located on the left radius rod arm.

BEARINGS

Undercarriage Axle Spindle Bearing

Tapered roller type bearings are standard on all 10" augers and should be repacked with grease and adjusted annually or as needed, determined by usage.

Care must be used in dismantling wheel bearing assemblies. First remove the dust cap by prying around the edges. Remove the cotter pin, slotted nut and flat washer. Carefully remove the hub and bearings from the spindle. Inspect all parts for wear or damage and replace with new ones, if necessary.



When reassembling the hub, repack both bearing cones with grease and fill the hub cavity 1/3 full. Place inner bearing assemblies into the hub, and then press seal into hub and carefully reinstall the hub on the spindle. When placing hub on spindle be careful not to damage the lip of the grease seal. Install outer bearing assembly into the hub, and replace flat washer and slotted nut. Then tighten the slotted nut to seal the bearings until the hub binds as you rotate hub. Back off the slotted nut to the next slot and install a new 5/32" x 1 1/4" long cotter pin. Replace dust cap.

Intake Guard Bronze Bearing

The auger has a bronze-with-graphite bearing at the intake end. This bearing requires no lubrication. If the bearing spins inside the retainer, the bearing should be replaced.

LUBRICATION AND MAINTENANCE

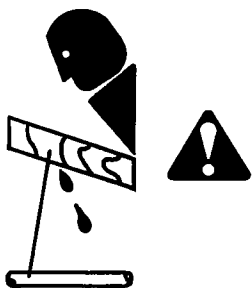
HYDRAULIC COMPONENTS - For Hydraulic Lift Undercarriage Models

Standard equipment for your hydraulic auger lift system includes the hydraulic cylinder, shut-off valve, fittings and hydraulic hose from the cylinder to the tractor, with the exception of fittings required to attach hose to tractor. A 1/2" female pipe thread tractor fitting (not furnished) is required to fit the hose leading to the shut-off valve.

The hydraulic shut-off valve, located at the end of the hose that connects to the tractor, must be fully open before raising or lowering the auger. The valve must be closed at all other times to prevent possible leak down or inadvertent hydraulic operation.

The hydraulic cylinder is equipped with a restrictor that limits the speed of operation and a vent plug in the rod end port. Check that the air breather is not plugged. Check the rod seals to see if they are leaking and replace damaged or leaking seals. Check to see if the cylinder is securely fastened to the lifting mounts.

Check the hydraulic hose and all the fittings to see if they are tight and not leaking hydraulic oil. Replace any hose or fittings that develop leaks. Replace the hose if it is cut or damaged. Keep all hydraulic lines away from moving parts.



CAUTION: Do not connect or disconnect hydraulic components when there is pressure within the system. Hydraulic systems are highly pressurized. Escaping hydraulic oil, even an invisible pinhole leak, can penetrate body tissues and cause serious injury. Use a piece of wood or cardboard when looking for leaks. Never use the hands or other parts of the body. When reassembling, make absolutely certain that all connections are tight. If injured by hydraulic oil escaping under pressure, see a doctor immediately. Serious infection or reaction may occur if medical attention is not received at once.

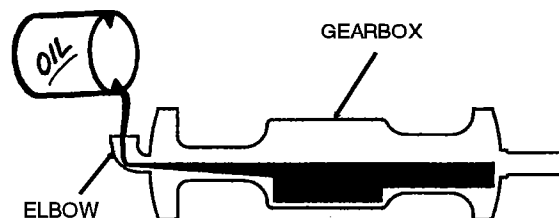
The hydraulic components supplied with your auger were selected to deliver the most efficient and economical use. Damaged or worn parts should be replaced with parts of the same type and size.

GEARBOX

Check and maintain oil level regularly. The unit must be level while performing this check. Remove the vented plug from the elbow. Oil is at the proper level when it is visible in the elbow. The use of SAE-80W-90 oil is recommended.

Care should be taken if the drive housing must be disassembled to repair or inspect the gearbox.

NOTE: To avoid dangerous situations, follow disassembly instructions on page 46.



BELT ADJUSTMENT

On drives that are powered by belts, the belt tension will need periodic adjustment. Use the adjustment bolts in the end of the motor mount. Turn equally. **DO NOT** overtighten.

LUBRICATION & MAINTENANCE

MANUAL (Friction Type) WINCH - For Manual Lift Undercarriage Models

Check the winch handle assembly on your auger to determine that it has been assembled correctly. (See page 32). There should be a locknut attached to the end of the input shaft to prevent inadvertent removal of the winch handle.

The lubrication checks listed below should be made to the winch periodically.

The auger should be in the lowered position with undercarriage lift arm slide against the upper stop when this inspection is being performed. Refer to operating and maintenance instructions furnished by the winch manufacturer (shipping in the operator's manual container) for proper inspection methods.

1. All gears should have a film of grease on them at all times.
2. Check brake disc. If worn to less than 1/16" thick, cracked or broken, replace both discs.
3. The following parts must be wet with oil at all times:
 - A. Two bushings located at ends of drum shaft.
 - B. The ratchet pawl pivot.

IMPORTANT: Do not get oil or grease on brake disc faces (located between ratchet gear brake hub and pinion shaft.)

See the manufacturer's information sheet that was shipped with this manual for additional instructions.

BLOW-OFF CAP

Before each seasonal use, remove the cap and reinstall. The cap should fit snug, but be able to slide off the end of the tube if the discharge should become plugged. It should be possible to tap the cap off by hand.

FLIGHTING

Flighting should be "polished" each season or after an idle period. See "Break-In Information" on page 9.

TROUBLE SHOOTING

LOW CAPACITY

The auger may not be getting enough grain. Check to see the intake has not "bridged over" restricting the flow.

The exposed flighting at the auger intake should be covered with grain to achieve maximum capacity.

Check auger speed. A low speed (below recommended speed) will result in low capacity. Refer to pages 9 thru 11 for flight information.

AUGER PLUGS

The auger may be getting too much grain and be "jamming" inside the housing. Reduce the amount of grain being fed into the auger.

On motor drive augers, the motor may be too small or wired improperly.

If wet grain or other hard to move material is being augered, use a larger size motor than recommended for normal use.

If the auger free of any foreign material, such as sacks, tarp corners, etc? A plug of the discharge end will cause an auger plug.

On electric powered models, check to see that all belts are lined up and tensioned properly.

AUGER LOWERING BY ITSELF - On Hydraulic Lift Undercarriage Models

Check all hydraulic fittings, hose and connections for leaks. Check that the hydraulic shut-off valve is closed.

AUGER WILL NOT RAISE OR LOWER - On Hydraulic Lift Undercarriage Models

Check if hydraulic shut-off valve is open. See if the hydraulic coupler is properly attached to the tractor and the tractor reservoir is full of oil.

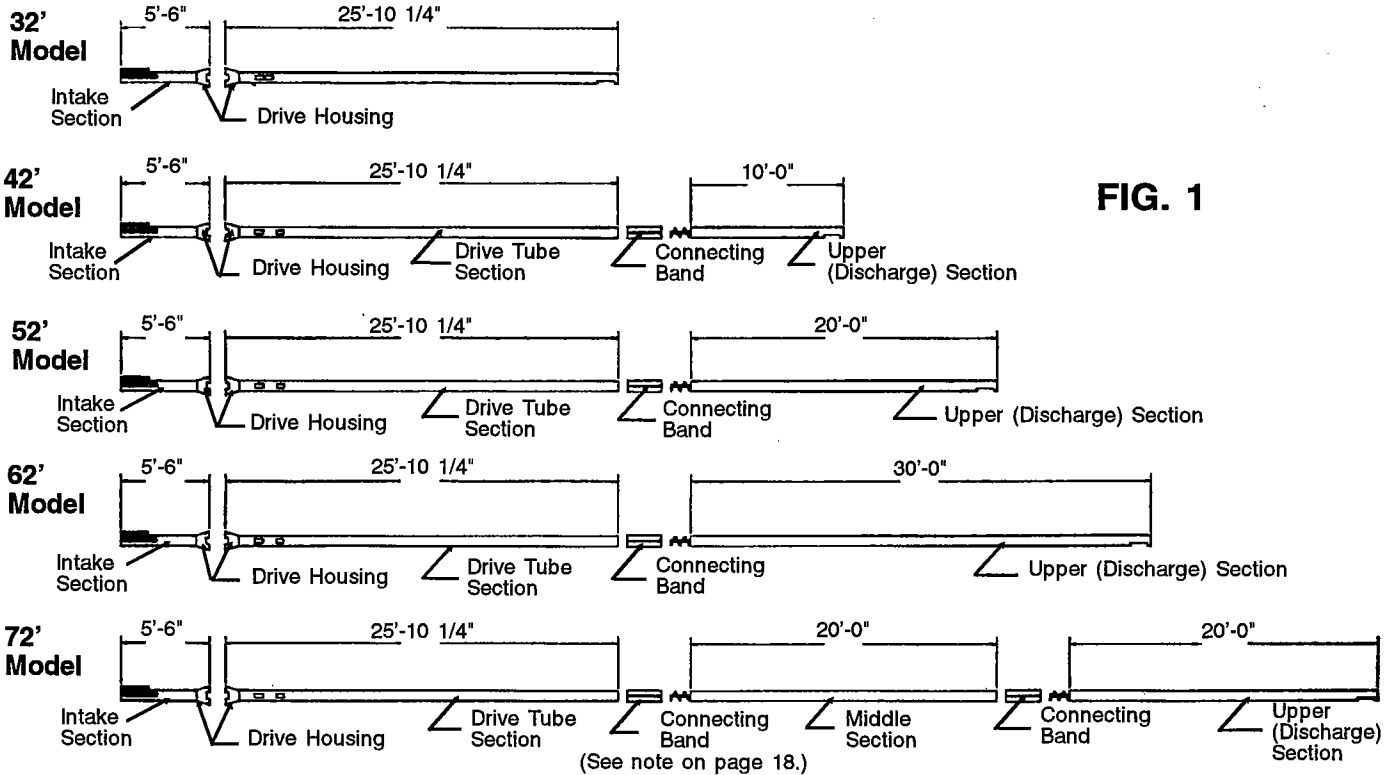
EXCESSIVE AUGER NOISE

Damage could have occurred to the auger flighting, thus causing noise. Damage usually occurs because of foreign material having been run through the auger. It may be necessary to remove the flighting for inspection. If this is to be done, consult Drive Housing Disassembly Instructions on page 46.

ASSEMBLY INSTRUCTIONS

AUGER HOUSING LAYOUT

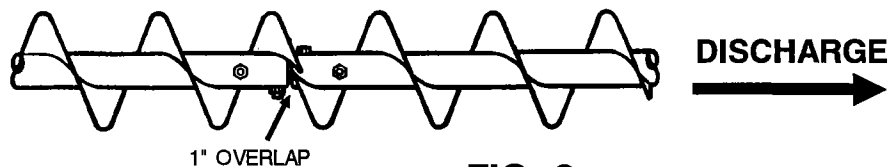
Choose an area on open level ground accessible to chain hoist or other lifting devices where the auger may be laid out full length. Arrange the tube sections in their relative positions. See Fig. 1. For ease of assembly, place the tubes on stands or blocks so the drive housings are off the ground with the tubes level. **NOTE:** Orient the 25'-10 1/4" tube sections so the decals are right side up and readable.



FLIGHT & GEARBOX ASSEMBLY

1. Before joint any flights, slide a connecting band onto the lower tube wherever tubes will banded. See Fig. 1. Flights located above the gearbox can then be bolted together using 7/16" x 3" long (grade 8) hex head capscrews with locknuts.

IMPORTANT: Flights are indexed to achieve timed connections. (A timed connection is where the flight pitch does not change across the connection.) When bolting timed flight sections together, position the flight ends so that the flighting overlaps and is continuous across the joint. See Fig. 2.



2. For banded tube joints, proceed as follows: Push the two tube sections together as tightly as possible. Slide the connecting band over the joint with about half the band on each side. Secure the band with six 3/8" x 1 1/2" long (grade 5) hex head capscrews with nylon locknuts. See Fig. 3 on the following page. **NOTE:** On the 72' auger with hydraulic lift, the lower connecting band must be installed with the clamp portion at the 10:30 or 1:30 clock positions rather than the typical 9:00 or 3:00 positions. This is to clear the center truss to be installed later.

ASSEMBLY INSTRUCTIONS

FLIGHT, GEARBOX & HOUSING ASSEMBLY - CONT.

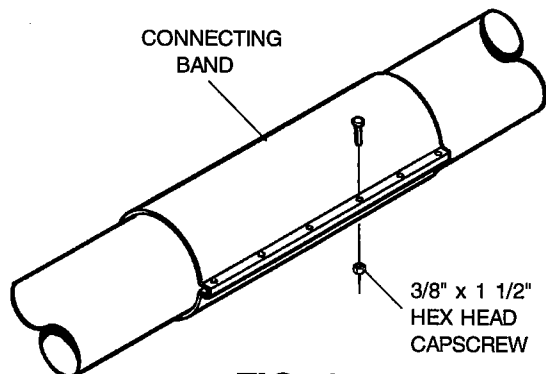
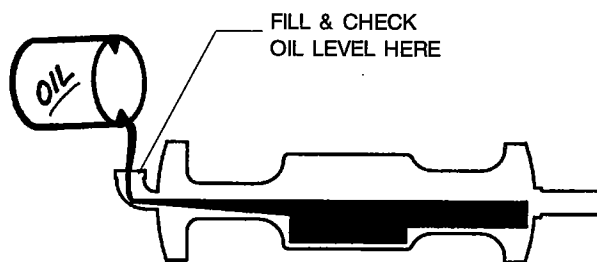


FIG. 3



IMPORTANT: DO NOT operate without oil!

FIG. 4

NOTE: If the unit is to be PTO driven, the drive can be assembled on either the right or left side of the auger. Fig. A on page 10 shows a PTO drive installed on the right-hand side. The gearbox is shipped ready for right hand installation. See Fig. 5. To convert it for left-hand installation, rotate the gearbox filler elbow 180° (so it will be pointing up after the gearbox is installed). See inset, Fig 5.

NOTE: If the unit is to be motor driven, the gearbox is ready to assemble as shown in Fig. 5. and must not be converted.

3. The gearbox is shipped without oil. Add 20 oz. of SAE 80W-90 to the gearbox using the vented plug in the elbow. Check oil level with the unit on level ground. Oil must be visible in the elbow. Fig. 4.

4. Connect the upper gearbox shaft to the upper flight assembly using two 7/16" x 3 1/2" long (grade 8) hex head capscrews, four 1/2" rubber washers, four 7/16" washers and two locknuts. Tighten the locknuts only enough to slightly compress the 1/2" x 1/4" thick rubber washers. **DO NOT** compress the washers more than 1/16" Fig. 5. **NOTE:** Observe the gearbox end caps where shafts will connect to flight. The thicker end cap must face intake end.

NOTE: Before the following connections are made, a sealant may be applied to the drive housing flanges. (Sealant not furnished.)

5. Assemble the gearbox to the upper drive housing using four 3/8" x 1" long (grade 5) hex head capscrews and lockwashers.

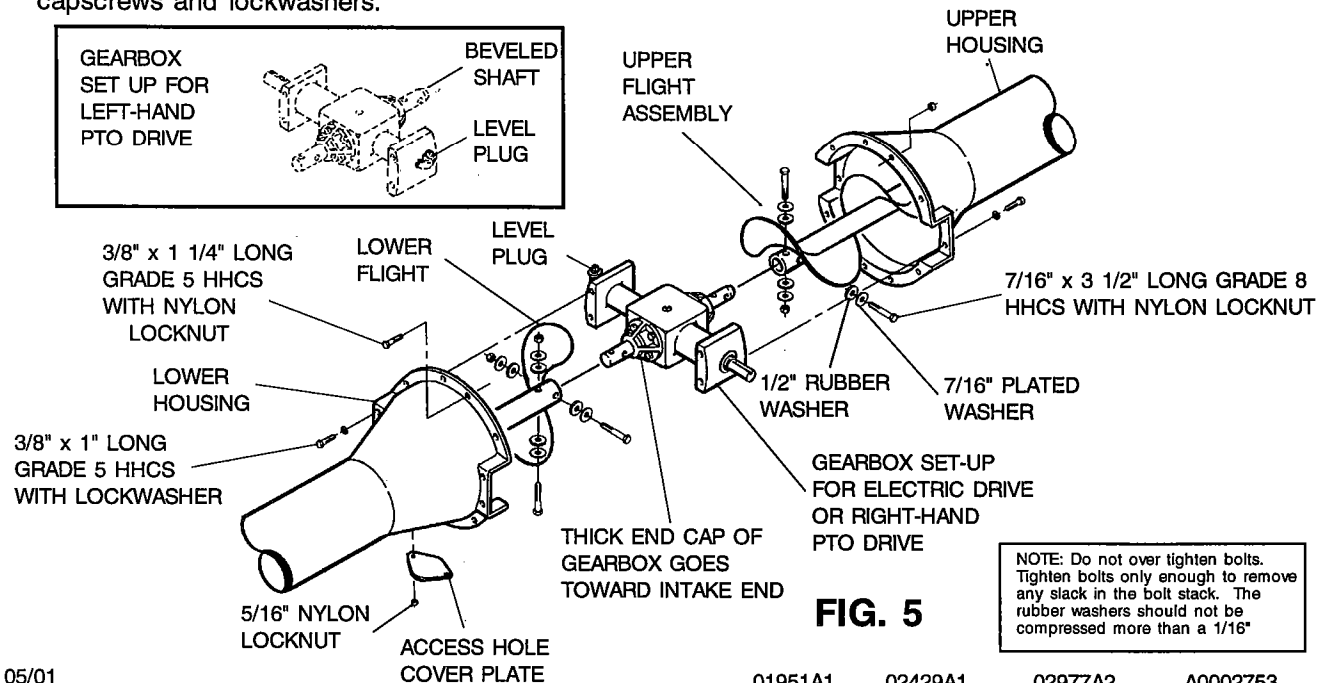


FIG. 5

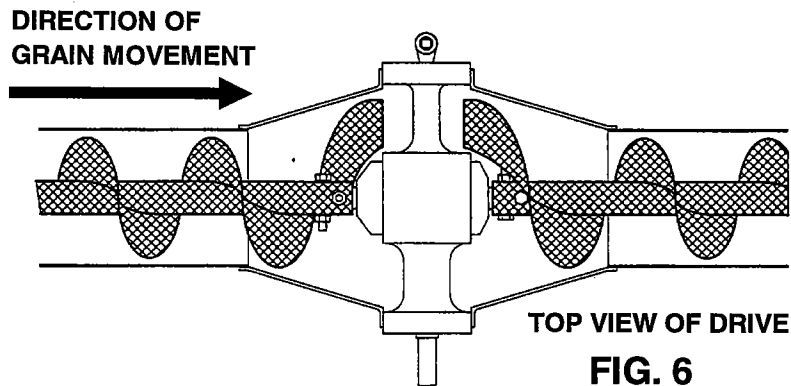
NOTE: Do not over tighten bolts. Tighten bolts only enough to remove any slack in the bolt stack. The rubber washers should not be compressed more than a 1/16"

ASSEMBLY INSTRUCTIONS

FLIGHT, GEARBOX & HOUSING ASSEMBLY

IMPORTANT:

When bolting the flight sections to the gearbox, the orientation of the flight sections to each other is important for flight balance and smooth operation. The ends of the flight sections should be on the same side of the gearbox.



6. Connect the lower flight to the gearbox with two 7/16" x 3 1/2" long (grade 8) hex head capscrews, four 1/2" rubber washers, four 1/2" washers and two locknuts. See Fig. 5 and 6.
7. Bolt the lower drive housing to the gearbox with four 3/8" x 1" long (grade 5) hex head capscrews and lockwashers. See Fig. 5 on previous page. When joining the drive housings, be careful to align the flight tail stub with the bronze bearing located on the intake guard.
8. Join the drive housing flanges using 3/8" x 1 1/4" (grade 5) hex head capscrews with nylon locknuts in the remaining holes.
9. Bolt the access hole cover plate to the lower drive housing with 5/16" nylon locknuts.

FLIGHT, GEARBOX AND HOUSING ASSEMBLY FOR UNITS EQUIPPED WITH INTERMEDIATE FLIGHT BEARINGS

1. Before joining any flights, slide a connecting band onto the lower tube wherever tubes will be banded. See Fig. 1 on page 18.
2. For flights located above the gearbox, slide a bearing hanger onto each flight connecting stub, then connect the flight sections together using 7/16" x 3" long (grade 8) hex head capscrews with side depress locknuts. See Fig. 7. The bearing hanger can then be allowed to rotate downward.

IMPORTANT: Flights are indexed to achieve timed connections. (A timed connection is where the flight pitch does not change across the connection.) When bolting timed flight sections together at the intermediate bearings, position the flight ends so they are open 90° to 180° to one another.

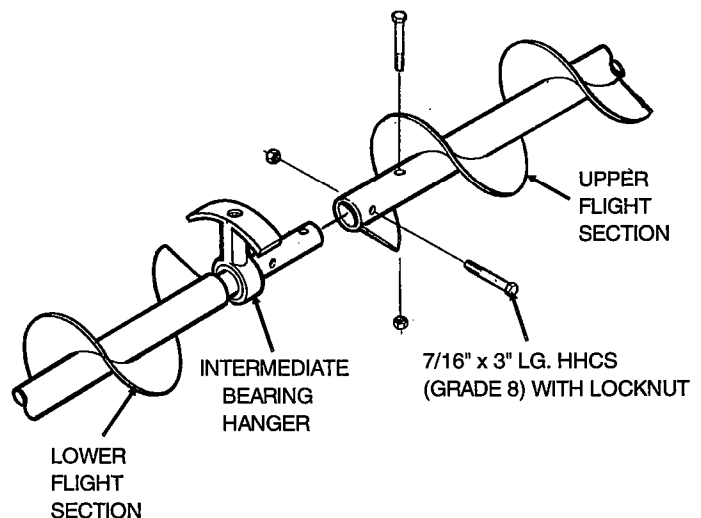


FIG. 7

ASSEMBLY INSTRUCTIONS

FLIGHT, GEARBOX & HOUSING ASSEMBLY - CONT. FOR UNITS WITH OPTIONAL INTERMEDIATE FLIGHT BEARINGS

3. For banded tube joints, proceed as follows: Push the two tube sections together as tightly as possible. Slide the connecting band over the joint with about half the band on each side of the joint. Secure the band with six 3/8" x 1 1/2" long (grade 5) hex head capscrews with nylon locknuts. See Fig. 3 on page 19.
4. Complete Steps 4 thru 9 on pages 19 & 20 to assemble gearbox, housing and flight. After all tubes and flights have been connected, the intermediate bearings can be mounted to the tubes. A special tool (called a "bearing positioning bar") has been provided to position the bearing hangers for assembly.
5. Use the bearing positioning bar to grab the bearing hanger stem through the housing slot to rotate the hanger into its upward position as follows:
 - A. Insert the double bended end of bearing positioning bar into slot and hook the bearing hanger stem. Rotate the stem upward as much as possible. See Fig. 8.
 - B. Remove the positioning bar and insert the single bent end into slot. Hook the bearing hanger stem and, by pulling upward, rotate it completely upright. See Fig. 9.

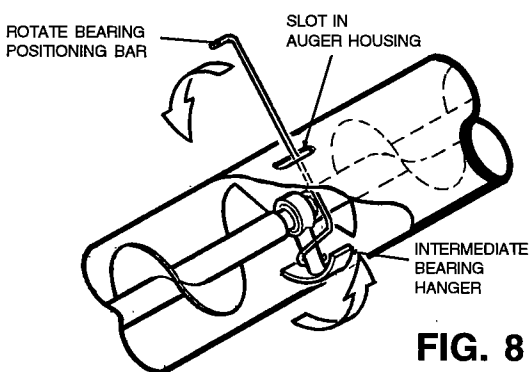


FIG. 8

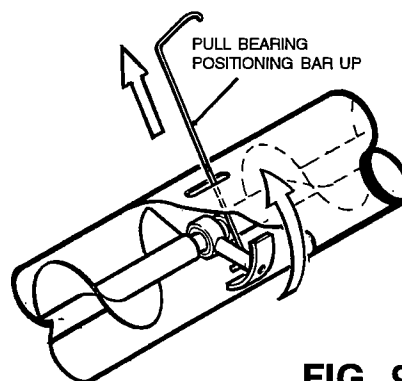


FIG. 9

- C. Attach each bearing hanger to the auger housing using a mounting plate, a 5/8" x 1 1/2" long (grade 5) hex head capscrew and lockwasher as seen in Fig. 10. Before tightening the mounting bolts, adjust the bearing hangers so they are centered between the ends of the auger flights. (See Fig. 11.) This can be done by sliding the hanger back and forth in the slot to determine the approximate center.

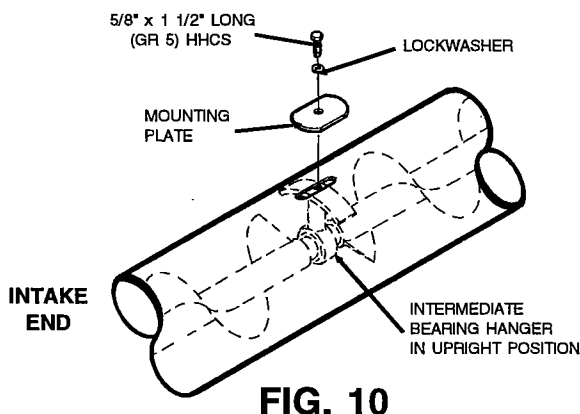


FIG. 10

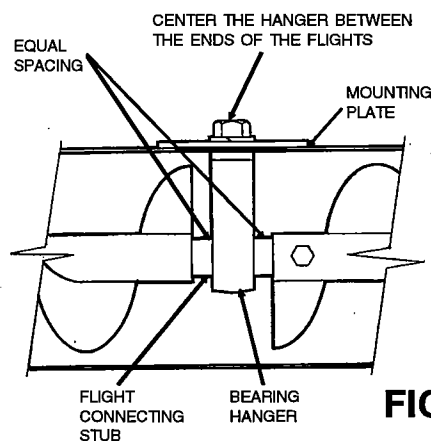


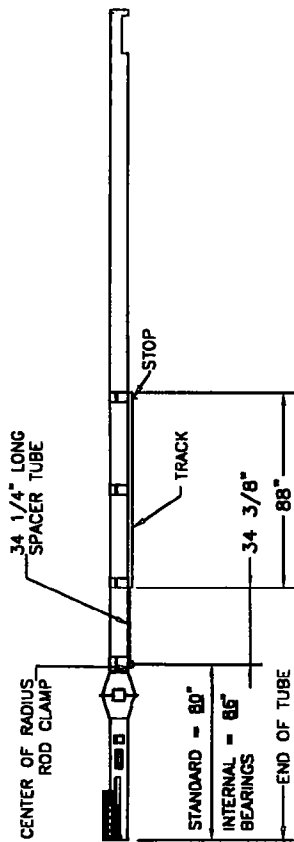
FIG. 11

ASSEMBLY INSTRUCTIONS

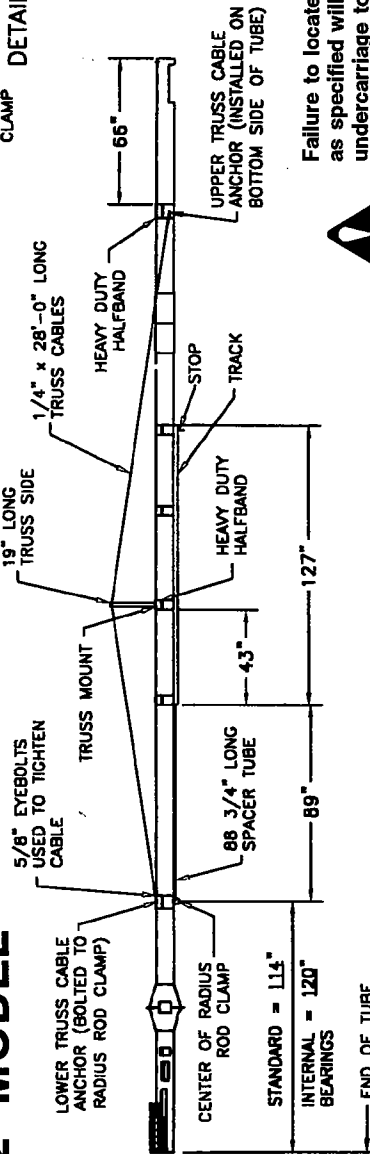
TRACK, TRUSS AND UNDERCARRIAGE ASSEMBLY FOR MANUAL LIFT UNDERCARRIAGE MODELS

Pages 22 to 33 cover assembly for Manual Lift Undercarriage Models **ONLY**. If your auger has a hydraulic lift undercarriage, then go to page 34 for Track, Truss and Undercarriage Assembly.

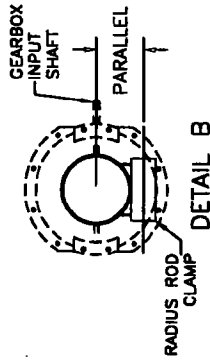
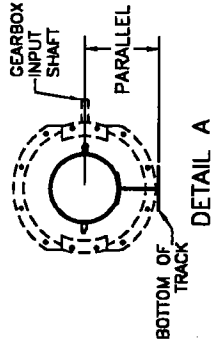
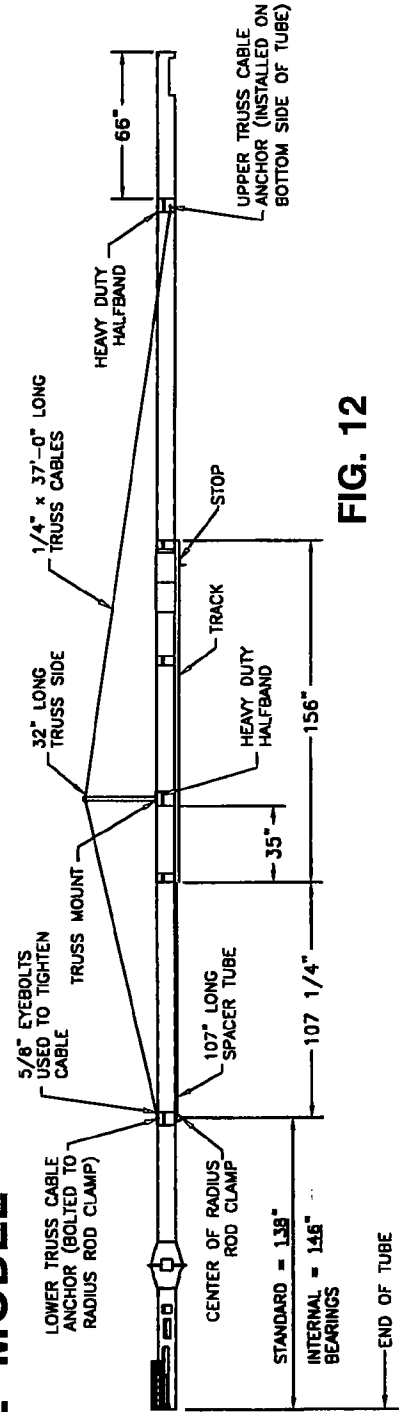
32' MODEL



42' MODEL



52' MODEL



Failure to locate components as specified will cause the undercarriage to fail and the auger to fall, resulting in property damage, personal injury or death.



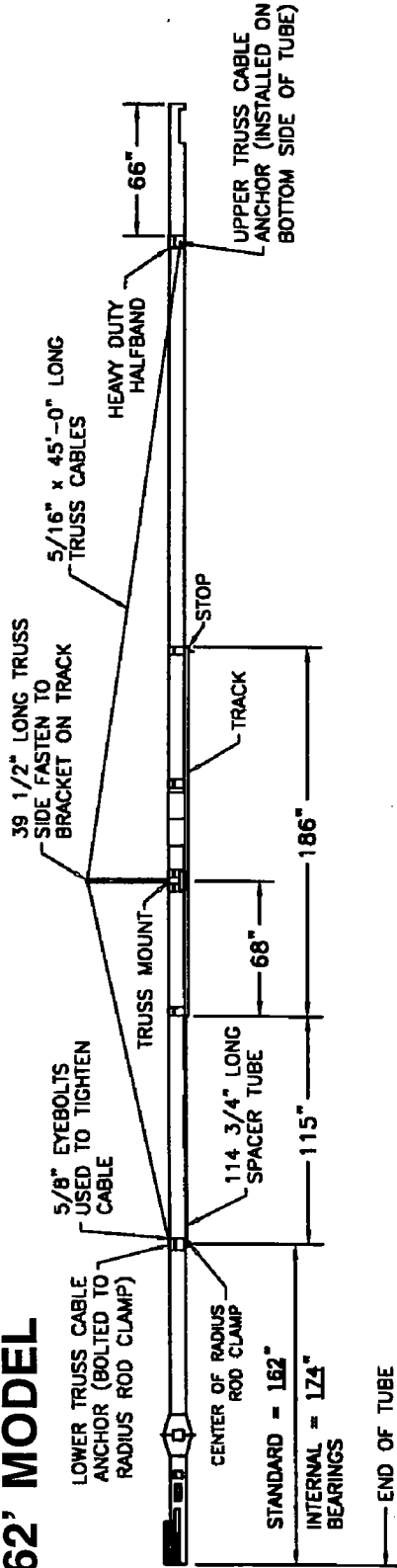
FIG. 12

ASSEMBLY INSTRUCTIONS

TRACK, TRUSS AND UNDERCARRIAGE ASSEMBLY FOR MANUAL LIFT UNDERCARRIAGE MODELS

! Failure to locate components as specified will cause the undercarriage to fail and the auger to fall, resulting in property damage, personal injury or death.

62' MODEL



72' MODEL

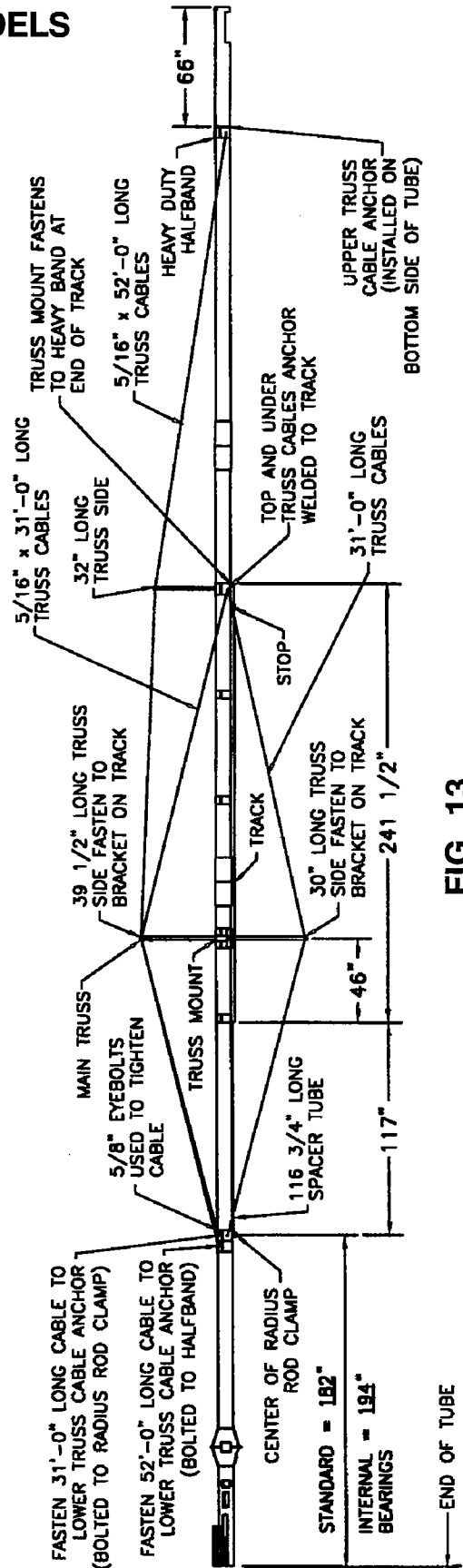


FIG. 13

ASSEMBLY INSTRUCTIONS

TRACK, TRUSS AND UNDERCARRIAGE ASSEMBLY

FOR MANUAL LIFT UNDERCARRIAGE - CONT.

See Fig. 12 on page 22 or Fig. 13 on page 23 for location of track, truss and undercarriage components.



WARNING: The location of components that band to the auger tube is critical for proper operation of the undercarriage system. If the auger components you have do not match the lengths specified in these instructions or you cannot position the components where instructions specify due to interference with other items mounted on the auger tube, contact your dealer or the factory immediately. **DO NOT MODIFY** or **SUBSTITUTE** other components in an effort to complete the assembly of the auger.

Failure to position the components in the proper location will cause the undercarriage to fail and the auger to fall, resulting in property damage, personal injury or death.

TRACK AND RADIUS ROD CLAMP COMPONENTS

- Step 1. Band the track to auger tube by using plain halfbands and four 5/16" x 1 1/2" long (grade 5) hex head capscrews and nylon locknuts per each band. When bolting the track to the auger tube, be sure to orientate so the bottom of the track is parallel with the center of gearbox input shaft. See Detail A on page 22.
- Step 2. Fasten spacer tube to collar at lower end of track with one 5/16" x 1 3/4" long (grade 5) hex head capscrew and nylon locknut. See Fig. 14
- Step 3. Fasten radius rod clamp to spacer tube with one 5/16" x 1 3/4" long (grade 5) hex head capscrew and nylon locknut. When bolting the radius rod clamp to the auger tube, be sure the pivot tube and bottom of track are parallel. See Detail B on page 22.
- Step 4. Fasten radius rod clamp to the auger tube using a halfband and six 3/8" x 1 1/2" long hex head capscrews with nylon locknuts. On 42', 52', 62' and 72' the heavy duty halfband will have truss anchors welded to it; the truss anchors must be positioned as shown on Fig. 20 and Fig. 21 on page 26.
- Step 5. On 72' models bolt another lower cable truss to the auger tube just below the radius rod clamp. Use a heavy duty halfband and six 3/8" x 1 1/2" long (grade 5) hex head capscrews with nylon locknuts to secure lower truss anchor to auger tube. See Fig. 21 on page 26.

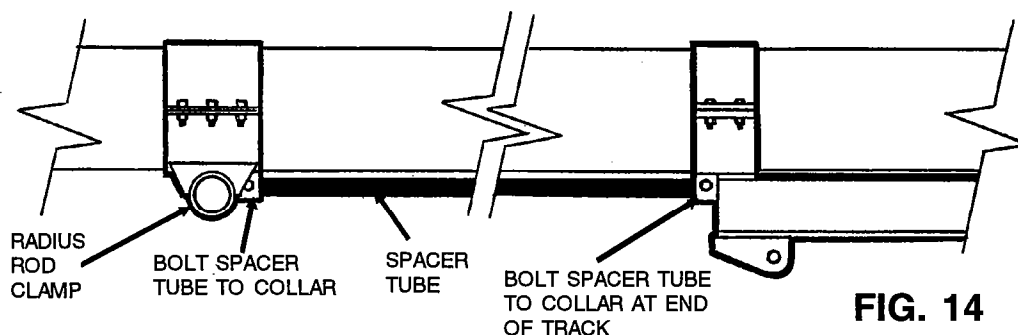


FIG. 14

TRUSS COMPONENT ASSEMBLY FOR 42', 52', 62' AND 72' MODELS

See Fig. 12 on page 22 or Fig. 13 on page 23 for cable lengths, truss mount and cable anchor locations.

- Step 6. On 42', 52' and 72' models - Fasten the truss mount to the heavy duty bands that are welded to the track. On the 42' model use four 3/8" x 1 1/2" long (grade 5) hex head capscrews and nylon locknuts. On 52' and 72' models use six 3/8" x 1 1/2" long (grade 5) hex head capscrews and nylon locknuts.
- Step 7. Mount the upper truss cable anchors to auger tube using a heavy duty band and six 3/8" x 1 1/2" long (grade 5) hex head capscrews and nylon locknuts. NOTE: The upper truss cable anchor is mounted on the under side of the tube. See Fig. 22 on page 26.
- Step 8. For 42', 52' & 62' Models, see instructions on top of page 25.
For 72' Models, see instructions on bottom of page 25.

ASSEMBLY INSTRUCTIONS

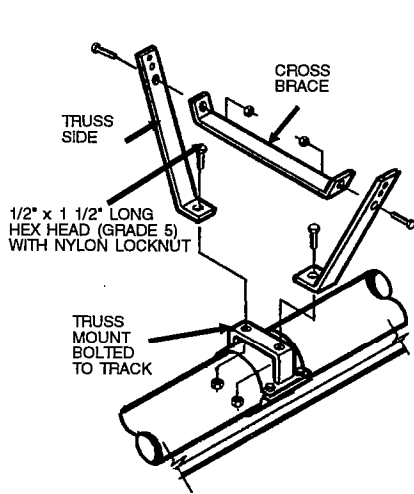
TRACK, TRUSS AND UNDERCARRIAGE ASSEMBLY FOR MANUAL LIFT UNDERCARRIAGE- CONT.

42', 52' & 62' MODELS ONLY

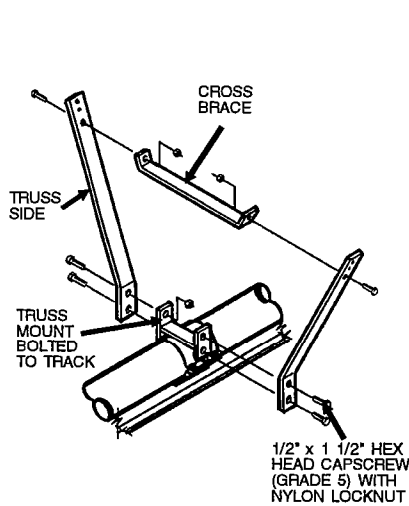
Step 8. Loosely bolt truss sides to truss mount.

Step 9. Bolt the crossbrace(s) between the truss sides with two 3/8" x 1 1/4" long (grade 5) hex head capscrews and nylon locknuts.

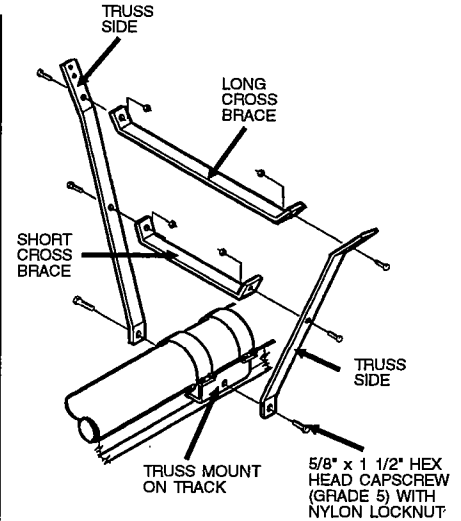
Step 10. Tighten the hardware holding truss sides to truss mounts.



42' MODEL MAIN TRUSS
FIG. 15



52' MODEL MAIN TRUSS
FIG. 16



62' MODEL MAIN TRUSS
FIG. 17

TRUSS COMPONENT ASSEMBLY FOR 72' MODEL ONLY

Step 8. Loosely bolt the 39 1/2" and 30" long truss sides to the main truss mount on the track using 5/8" x 2" long (grade 5) hex head cap screw with nylon locknuts.

See Fig. 18.

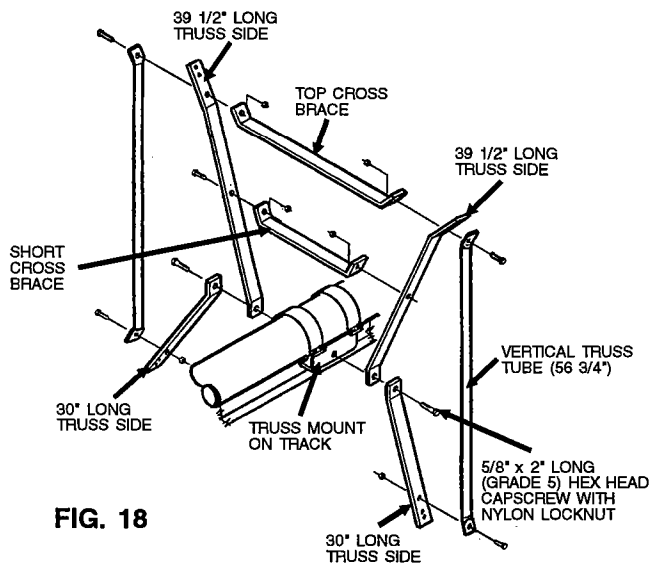


FIG. 18

72' MODEL MAIN TRUSS

Step 9. Bolt the short cross brace between the 39 1/2" long truss sides using two 3/8" x 1 1/2" long (grade 5) hex head cap screw and nylon locknuts. Bolt the top cross brace between the truss sides and the vertical truss tubes using two 3/8" x 1 1/2" long (grade 5) hex head cap screws and nylon locknuts. Bolt the other end of the vertical truss tube to the 30" truss sides using two 3/8" x 1 1/4" long (grade 5) hex head cap screws and nylon locknuts. See Fig. 18. Tighten the hardware holding the truss sides to the truss mount.

Step 10. Loosely bolt truss sides to upper truss mount. See Fig. 19. Bolt the crossbrace between the truss sides with two 3/8" x 1 1/4" long (grade 5) hex head cap screws and nylon locknuts. Tighten the hardware holding truss sides to truss mounts.

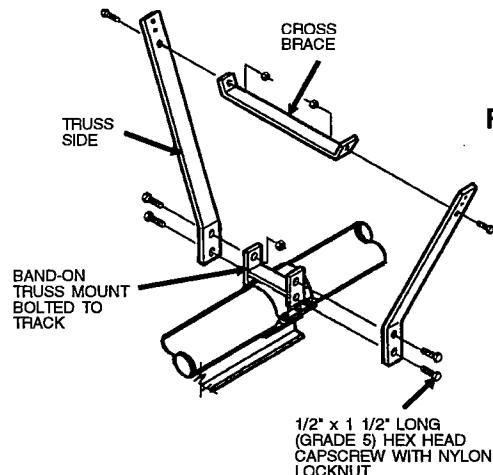


FIG. 19

72' MODEL UPPER TRUSS

ASSEMBLY INSTRUCTIONS

TRACK, TRUSS AND UNDERCARRIAGE ASSEMBLY FOR MANUAL LIFT UNDERCARRIAGE - CONT.

TRUSS CABLE RIGGING FOR 42', 52', 62' & 72' MODELS

Step 11. Install the eyebolts into the lower truss anchor with the eye of the bolts pointing towards the discharge end of the auger. Install two nuts on each eyebolt. The 42', 52' and 62' models use two eyebolts. See Fig. 20. The 72' models use four eyebolts. See Fig. 21.

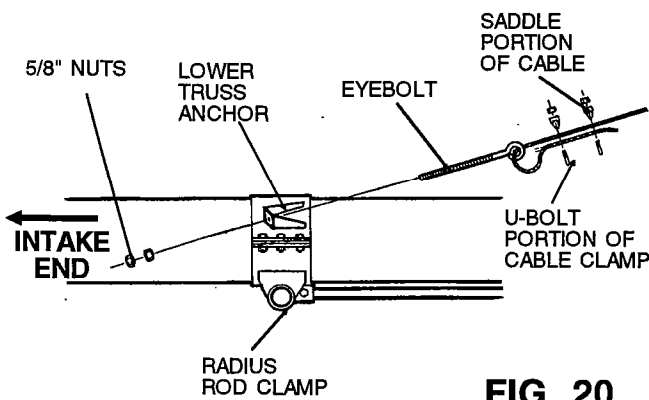


FIG. 20

**42', 52' & 62' MODEL
LOWER CABLE ANCHOR DETAIL**

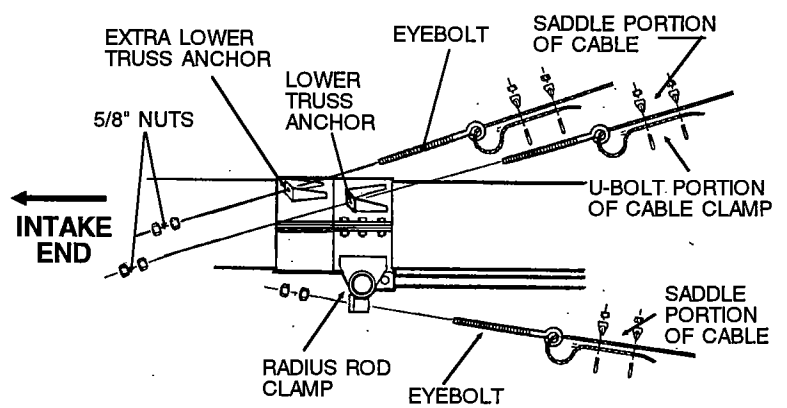


FIG. 21

**72' MODEL
LOWER CABLE ANCHOR DETAIL**

Step 12. Attach truss cables to upper cable anchors using two cable clamps per each cable. **NOTE:** Secure the clamp u-bolts against the loose end of the cable.

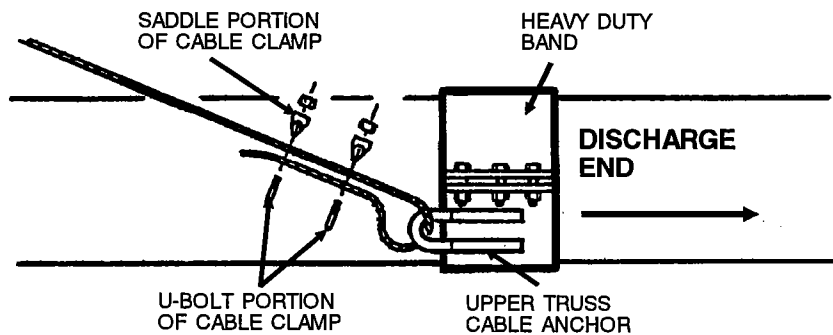


FIG. 22

UPPER TRUSS CABLE ANCHOR

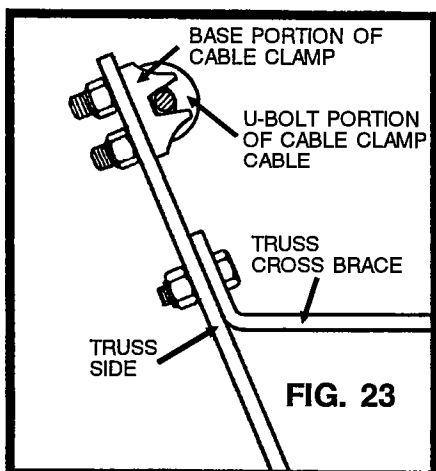
Step 13. Run the cables over the truss crossbrace, then towards the intake end of the auger. On 72' models use two sets of cables for upper truss. The 52' long set will run over the upper truss then over the main truss. A set of two 31'-0" long cables will run over the main truss then towards the intake end of the auger.

ASSEMBLY INSTRUCTIONS

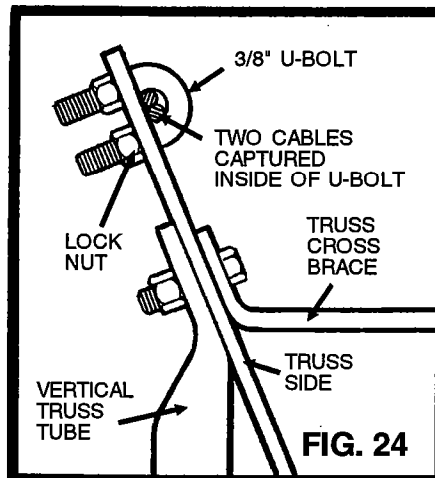
TRACK, TRUSS AND UNDERCARRIAGE ASSEMBLY FOR MANUAL LIFT UNDERCARRIAGE - CONT.

TRUSS CABLE RIGGING FOR 42', 52', 62' & 72' MODELS - CONT.

- Step 14. Attach the cables to the truss sides. On 42', 52' and 62' models and the upper truss for 72' models, use 3/8" cable clamp to fasten the cables to truss sides. See Fig. 23. On the lower truss for 72' models, use a 3/8" u-bolt and two locknuts to hold two cables to the truss side. See Fig. 24.
IMPORTANT: DO NOT tighten the 3/8" clamps and 3/8" u-bolts at this time. The cables must be able to freely slide through the clamps or u-bolts while taking up the slack in step 16.



TRUSS CABLE TO TRUSS SIDE ON
42', 52' & 62' MODELS AND THE
UPPER TRUSS ON 72' MODELS



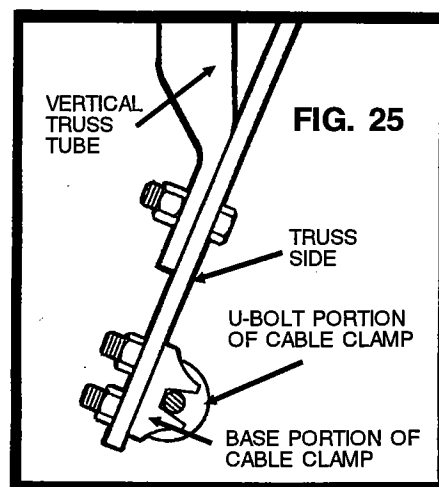
TRUSS CABLE TO TRUSS SIDE ON
LOWER TRUSS ON 72' MODELS

- Step 15. Attach truss cables to eyebolts using two cable clamps per each cable. **NOTE:** Secure the clamp u-bolt against loose end of cable. See Fig. 20. on page 26 for 42', 52' & 62' models. See Fig. 21 on page 26 for 72' models.
- Step 16. Using eyebolts tighten cables until they are reasonably snug. Tighten both cables the same. **DO NOT OVERTIGHTEN.** Sight down the tube to make sure all sections are straight. Some adjustment can be made after auger is completely set up.
- Step 17. Tighten the 3/8" cable clamps or 3/8" u-bolts holding the cable to the truss sides.

UNDERTRUSS CABLE RIGGING FOR 72' MODELS ONLY

Run the other set of 31'-0" long cables so they will fasten to the 30" long truss side (hanging below track) using 3/8" cable clamps. See Fig. 25.

Attach the 31'-0" long cables to eyebolts using two cable clamps per each cable. **NOTE:** Secure the clamp u-bolt against loose end of cable. See Fig. 21 on page 26. Using eyebolts tighten cables to remove slack until the cables are reasonably snug. Tighten cables equally. **DO NOT OVERTIGHTEN.** Sight down the tube to make sure all sections are straight. Some adjustments can be made after auger is completely set up. Tighten the 3/8" cable clamps or 3/8" u-bolts holding the cable to the truss sides.



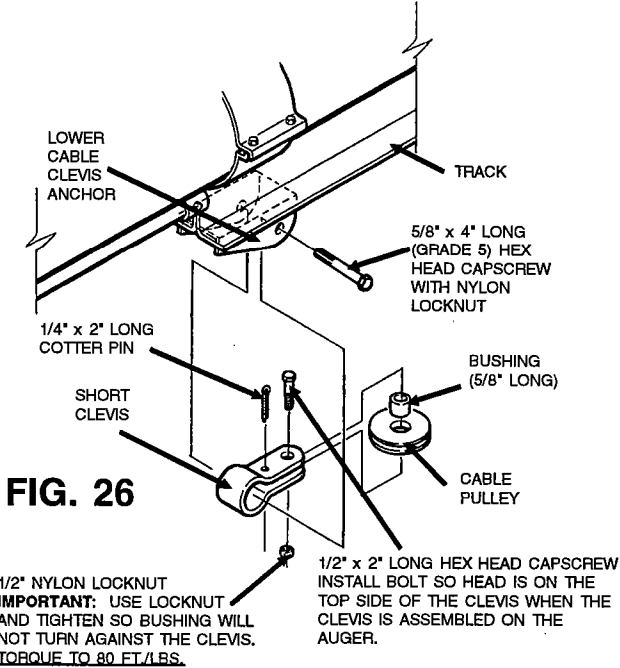
ASSEMBLY INSTRUCTIONS

TRACK, TRUSS AND UNDERCARRIAGE ASSEMBLY FOR MANUAL LIFT UNDERCARRIAGE MODELS - CONT.

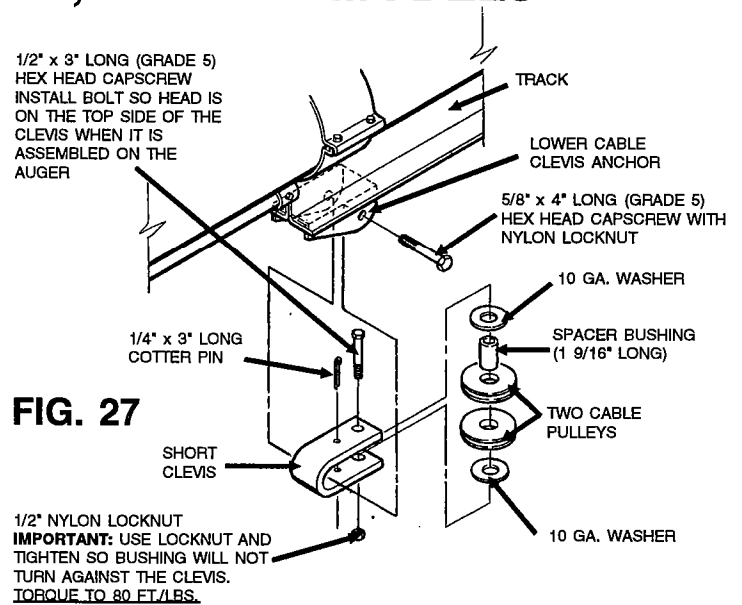
TRACK CABLE PULLEY AND CLEVIS COMPONENTS

Step 18. Assemble the cable pulley(s) to the short clevis. Then fasten clevis to anchor at lower end of track using 5/8" x 4" long (grade 5) hex head capscrew and nylon locknut.

32' & 42' MODELS

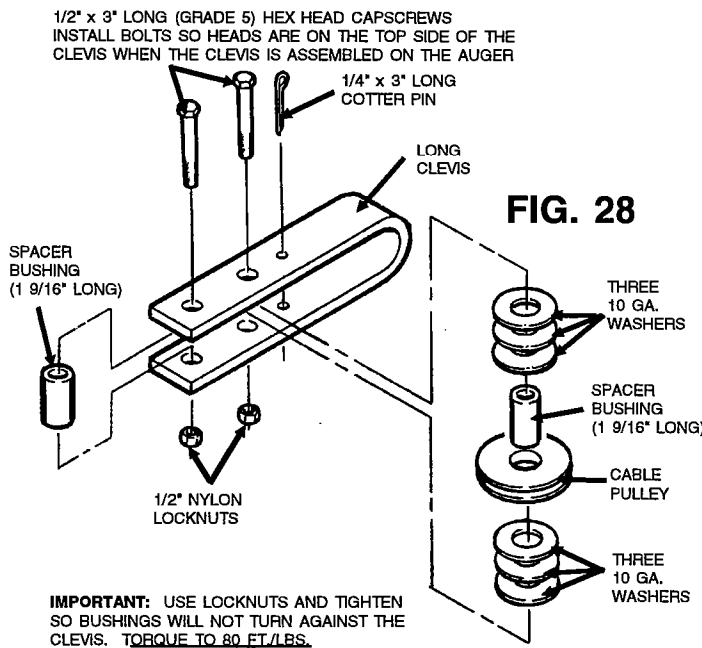


52', 62' & 72' MODELS

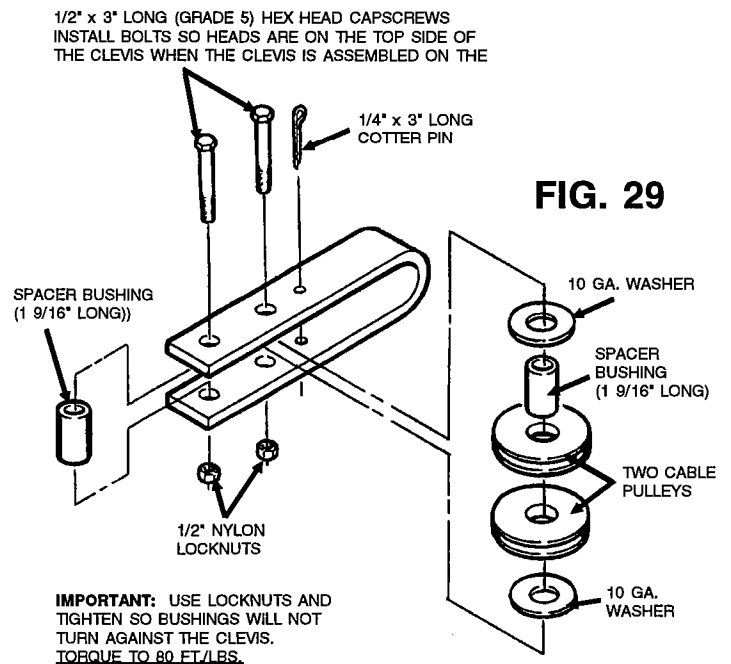


Step 19. Assemble pulley(s), spacer bushings, washers and cotter pin to long clevis.

32' & 42' MODELS



52', 62' & 72' MODELS

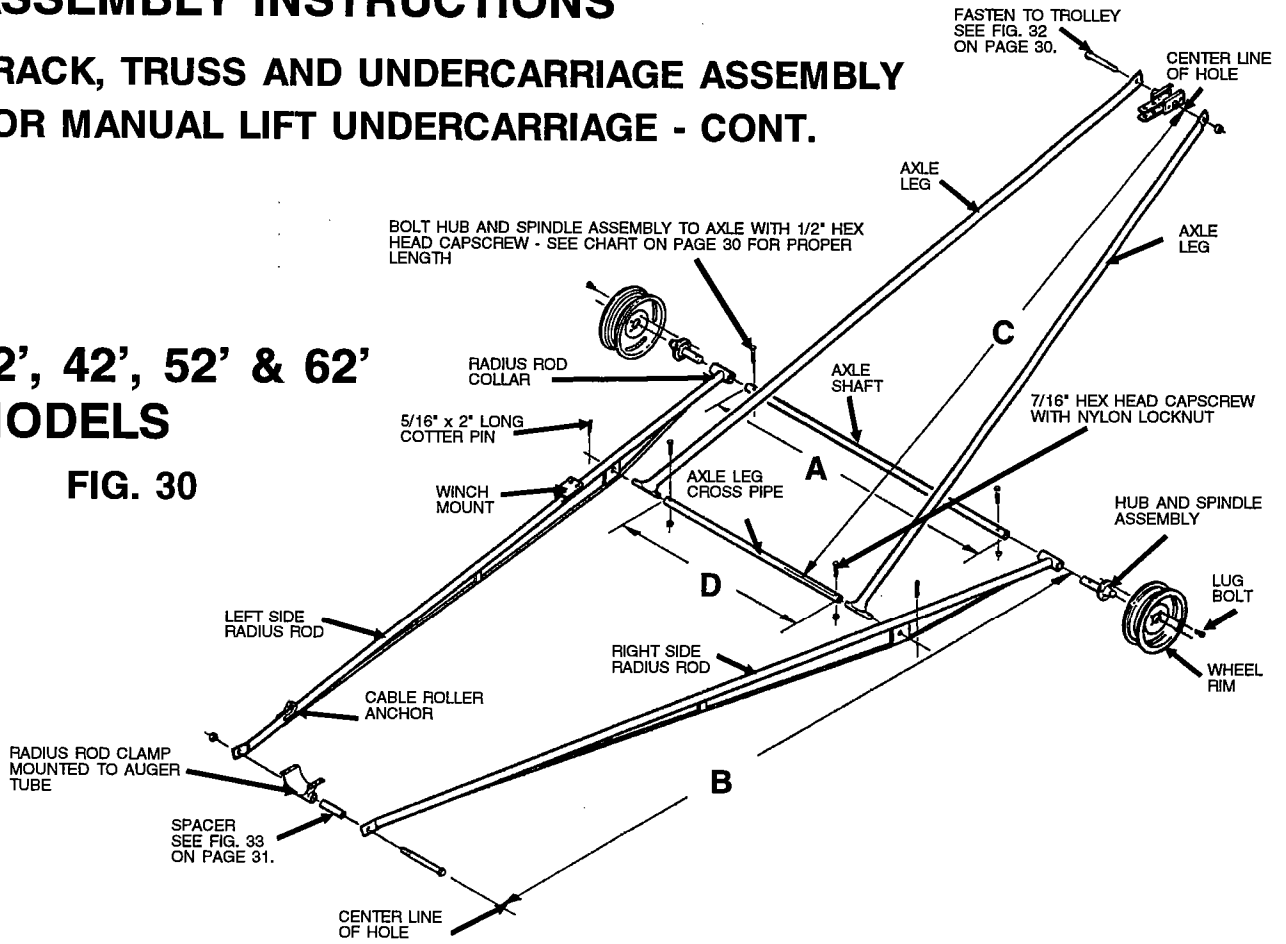


ASSEMBLY INSTRUCTIONS

TRACK, TRUSS AND UNDERCARRIAGE ASSEMBLY FOR MANUAL LIFT UNDERCARRIAGE - CONT.

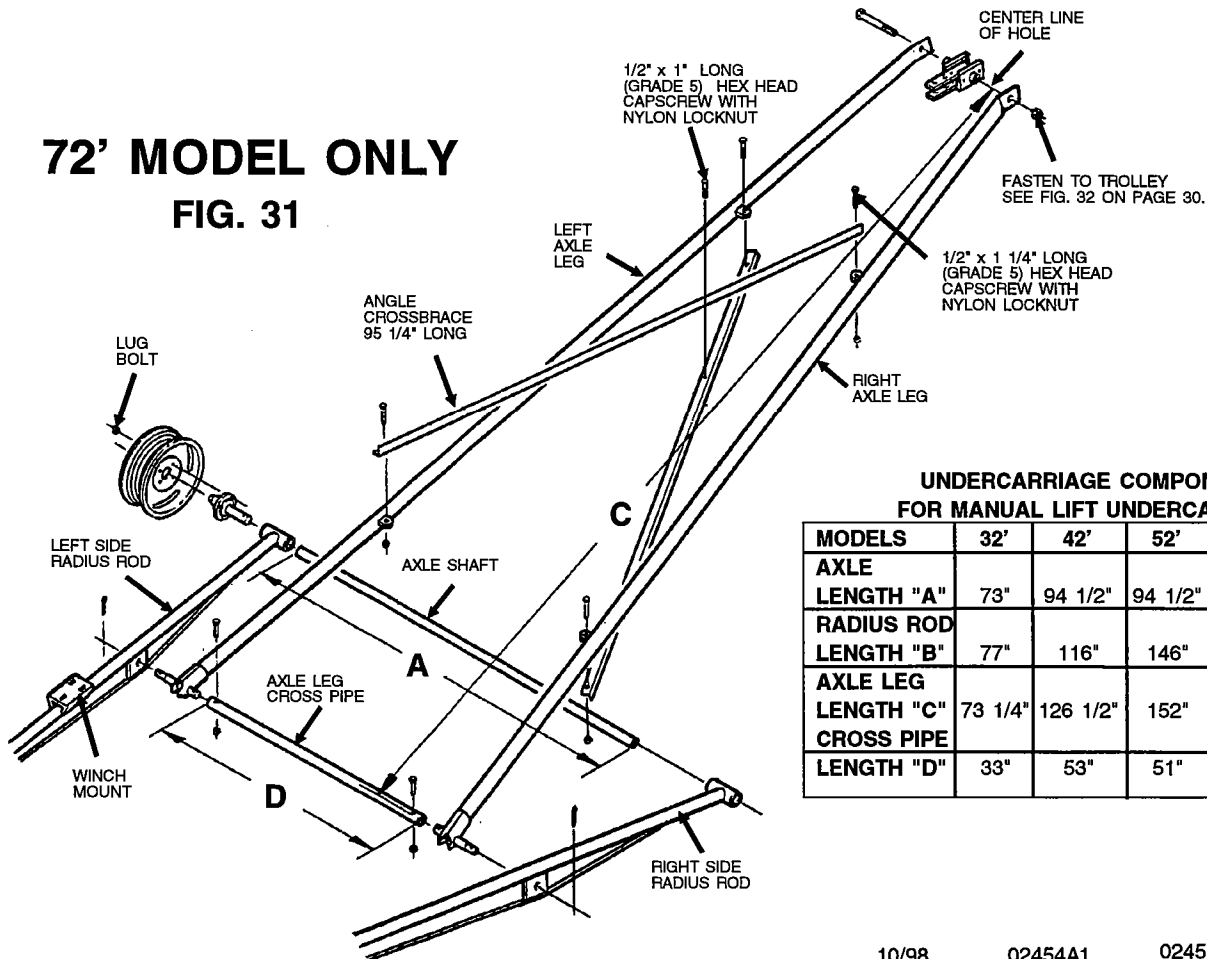
32', 42', 52' & 62' MODELS

FIG. 30



72' MODEL ONLY

FIG. 31



UNDERCARRIAGE COMPONENTS FOR MANUAL LIFT UNDERCARRIAGE

MODELS	32'	42'	52'	62'	72'
AXLE LENGTH "A"	73"	94 1/2"	94 1/2"	93"	120"
RADIUS ROD LENGTH "B"	77"	116"	146"	176 3/4"	209 1/4"
AXLE LEG LENGTH "C"	73 1/4"	126 1/2"	152"	178"	193"
CROSS PIPE LENGTH "D"	33"	53"	51"	49 3/4"	72 1/2"

ASSEMBLY INSTRUCTIONS

TRACK, TRUSS AND UNDERCARRIAGE ASSEMBLY FOR MANUAL LIFT UNDERCARRIAGE - CONT.

RADIUS ROD AND AXLE LEG COMPONENTS

See chart on page 29 to be sure that the undercarriage components are the correct length for the size of auger that is being assembled.

- Step 20. Lay out the radius rods (with trussing and square plate). The flattened ends of the radius rods must be toward the intake end of the auger. When standing at the intake end and facing the discharge end of the auger, the radius rod with the winch mount must be on the left side. See Fig. 30 or 31 on page 29.
- Step 21. Bolt the axle leg cross pipe to the axle legs with one 7/16" long (grade 5) hex head capscrew and nylon locknut in each end. On 32', 42', 52' & 62', models use 7/16" x 2" long (grade 5) hex head capscrew. On 72' models use 7/16" x 2 1/4" long (grade 5) hex head capscrew. Insert the short shafts on the axle legs into the square plates welded to the radius rods. Insert and spread one 5/16" x 2" cotter pin in the end of each short shaft.
- Step 22. On 72' models **ONLY** - fasten angle crossbraces between the axle legs. Secure angles to ears on axle legs with four 1/2" x 1 1/4" long (grade 5) hex head capscrews and nylon locknuts. **DO NOT** tighten hardware until trolley is assembled to axle legs in step 26. Bolt the middle of the angle crossbraces together using one 1/2" x 1" long (grade 5) hex head capscrew and nylon locknut. **DO NOT** tighten hardware until later.
- Step 23. Slide the axle shaft through the pipes on the ends of the radius rods.
- Step 24. The hubs, bearings, seals and spindles are assembled at the factory and are pressure packed with grease at that time. Slide the hub and spindle assembly into the undercarriage axle and secure with a hex head capscrew and nylon locknut. See chart A for bolt size.
- Step 25. Secure tire and rim to hub with lug bolts.
- Step 26. Lift the discharge end of the auger tube with adequate hoist, attaching it about 2/3 of the way from the intake end of the auger. Raise the discharge end of the tube assembly about 6'. Roll the undercarriage into position. Lift the axle legs and bolt trolley and trolley spacer with long clevis and pulley assembly together using 3/4" x 7" long (grade 5) hex head capscrew, flat washers and nylon locknut. See Fig. 32.

LENGTH	BOLT SIZE
32'	1/2" x 2 1/2" long
42', 52'	1/2" x 3 1/4" long
62', 72'	1/2" x 3 3/4" long

**CHART A
SPINDLE BOLT SIZE**



IMPORTANT: The trolley must be assembled to the track in a manner whereby it cannot be removed from the track.

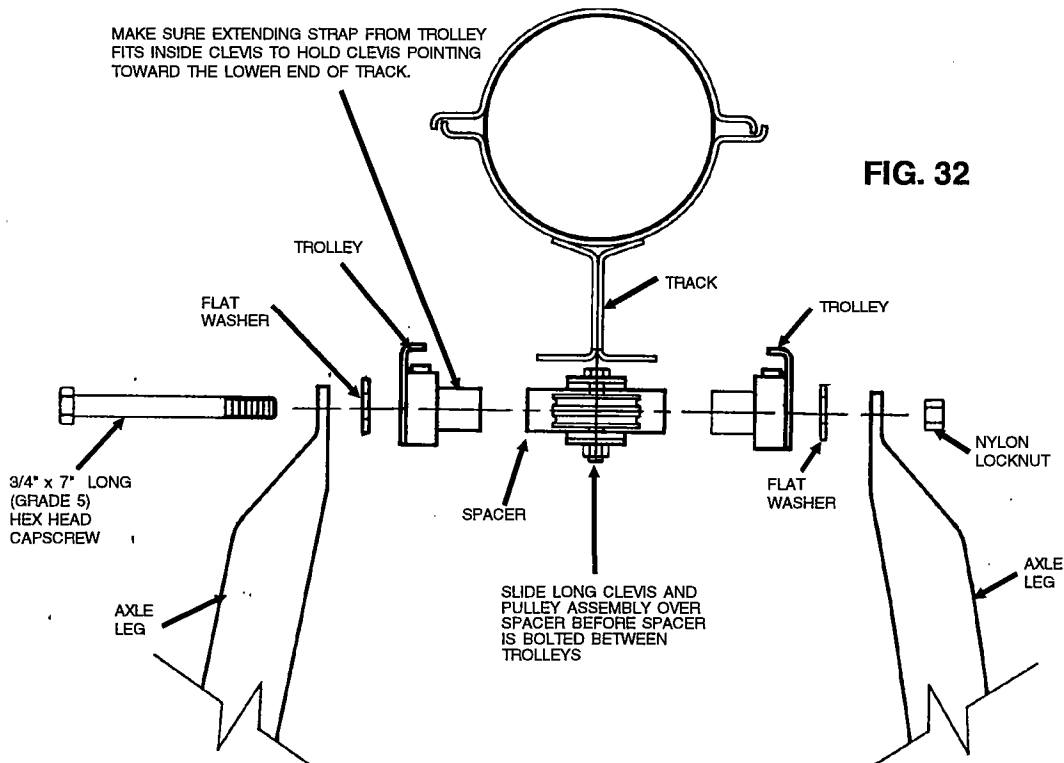


FIG. 32

ASSEMBLY INSTRUCTIONS

TRACK, TRUSS AND UNDERCARRIAGE ASSEMBLY FOR MANUAL LIFT UNDERCARRIAGE - CONT.

RADIUS ROD AND AXLE LEG COMPONENTS - CONT.

- Step 27. Slide the trolley along the track to the stop toward the discharge end. Lift the auger with the hoist high enough to line up the radius rods with radius rod clamp.
- Step 28. Insert the pivot pipe spacer into the pipe on the radius rod clamp. Then insert a 3/4" x 11" long (grade 5) hex head capscrew through a flat washer, one radius rod, the spacer and then the other radius rod and another flat washer and a nylon locknut. See Fig. 33.

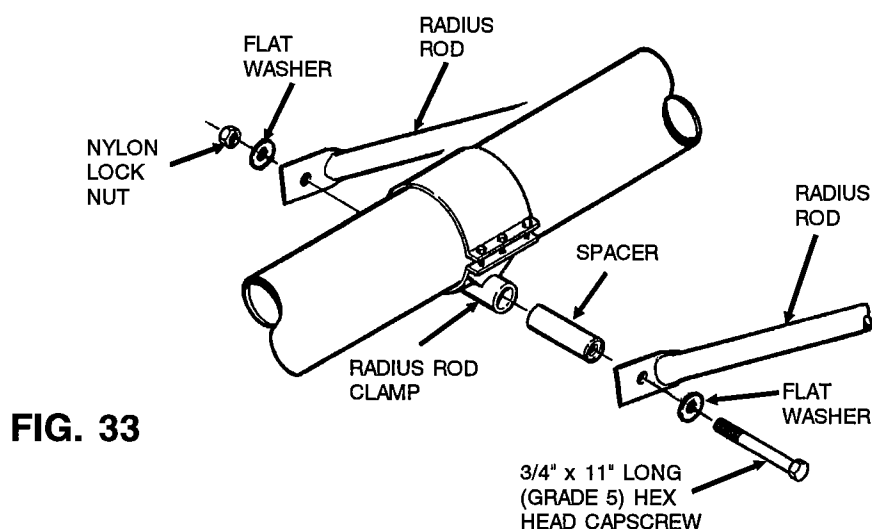


FIG. 33

- Step 29. Check to see all undercarriage bolts and fasteners are tight and assembled correctly. On 72' models tighten all the 1/2" hex head capscrews that fasten the angle crossbraces to axle legs in Step 22.
- Step 30. **Before releasing the hoist and with the intake on the ground, check the transport height of the auger (with the trolley touching the down stop) by measuring the distance from the top of the auger tube (at the discharge end) to the ground. Use the transport height chart on page 5 to check your measurement. If your measurement does NOT fit into the range on the chart for your size auger, then go back and check the following items:**
- Location of radius rod clamp and track - See page 22 and 23.
 - The length of undercarriage components - See page 29.
 - The length of auger tubes - See page 18.
 - Is the discharge end of auger tube sagging because the truss cables require tightening? - See Step 16 on page 27.

If you have checked all of the above items and your measured discharged height is **NOT** in the range specified in the transport height chart, call your dealer or the factory immediately. **DO NOT CONTINUE TO ASSEMBLE THE AUGER** and do not release the hoist with the auger in this condition.

- Step 31. When the height of the auger is correct as described in Step 30 the hoist may be released.

ASSEMBLY INSTRUCTIONS

TRACK, TRUSS AND UNDERCARRIAGE ASSEMBLY FOR MANUAL LIFT UNDERCARRIAGE MODELS - (CONT.)

WINCH AND CABLE COMPONENTS

Step 32. Hook clevis plates over anchor rod on left radius rod. Then assemble bushing, flat washers and cable pulley between the clevis plates using 1/2" x 2" long hex head capscrew (grade 5) and nylon locknut. After the locknut is tightened, check to see that the clevis plates are captured on the anchor rod and cannot come off. See Fig. 34.

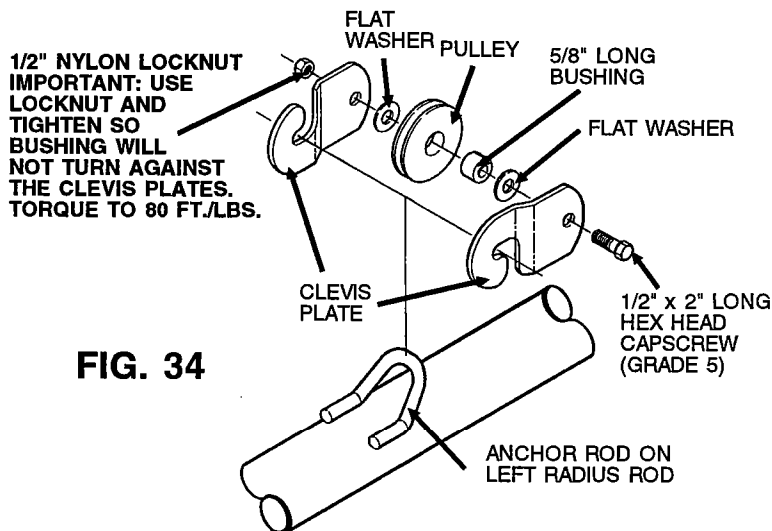


FIG. 34

Step 33. Align slot of handle with flat portion of winch pinion shaft. Use hex nut to hold handle in place and tighten securely. For additional winch information, follow the instructions and precautions listed in the material supplied with the winch from the manufacturer. See Fig. 35.

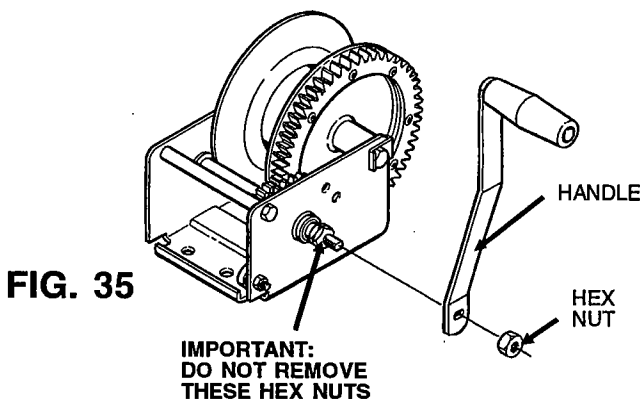


FIG. 35

Step 34. Attach 1/4" lift cable to winch drum so cable will wrap over winch drum on 32', 42', 52' and 62' models and under winch drum for 72' models when turning handle in a clockwise direction. See Fig. 36. From inside of drum, insert the cable through one round hole in the drum side, until it extends 1" past the two square holes. Next clamp the cable to the outside of the drum with the cable keeper, using two 3/16" x 3/4" carriage bolts, lock washers and nuts. Be sure that the carriage bolt heads are on the inside of the drum.

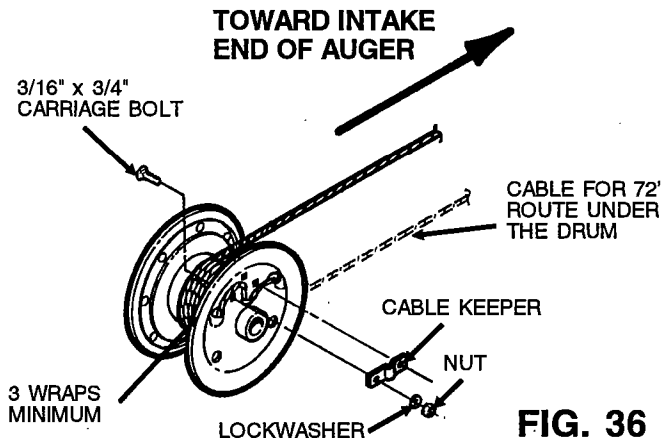


FIG. 36



CAUTION: The rope keeper alone will not hold the weight of the auger. There should be enough cable so that when the auger is all the way down there are at least 3 turns of cable on the winch drum. Always keep a minimum of three (3) turns of cable on the winch drum. If there are not (3) turns of cable around the winch drum when the auger is fully lowered, then the cable must be replaced with a longer one.

ASSEMBLY INSTRUCTIONS

TRACK, TRUSS AND UNDERCARRIAGE ASSEMBLY FOR MANUAL LIFT UNDERCARRIAGE - CONT.

WINCH AND CABLE COMPONENTS

Step 35. Bolt winch assembly to mount on left radius rod so the winch drum is towards the intake end of auger. Use three 3/8" x 1" long (grade 5) hex head capscrews, flat washers, and nylon locknuts to attach winch to mount. See Fig. 37.

Step 36. Rig the lift cable from the winch through the various pulleys and then anchor to trolley. Different lengths of augers will require different rigging of the lift cable. See Fig. 38 for 32' & 42' models or Fig. 39 for 52', 62' and 72' models.

IMPORTANT: Secure lift cable to trolley with two cable clamps, with the clamp u-bolt against the loose end of the cable.

IMPORTANT: Do not disassemble pulley(s) from clevis(s) during rigging.

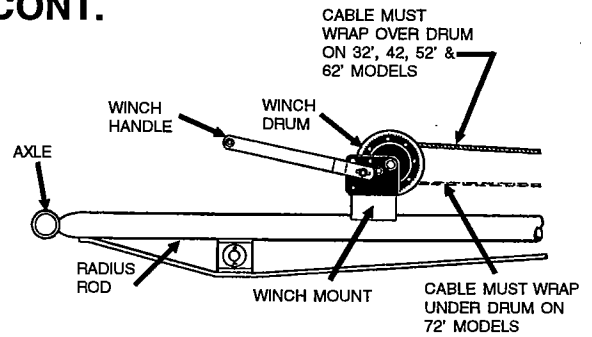
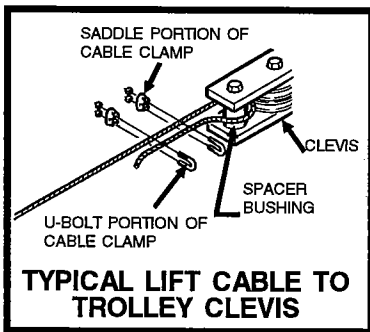
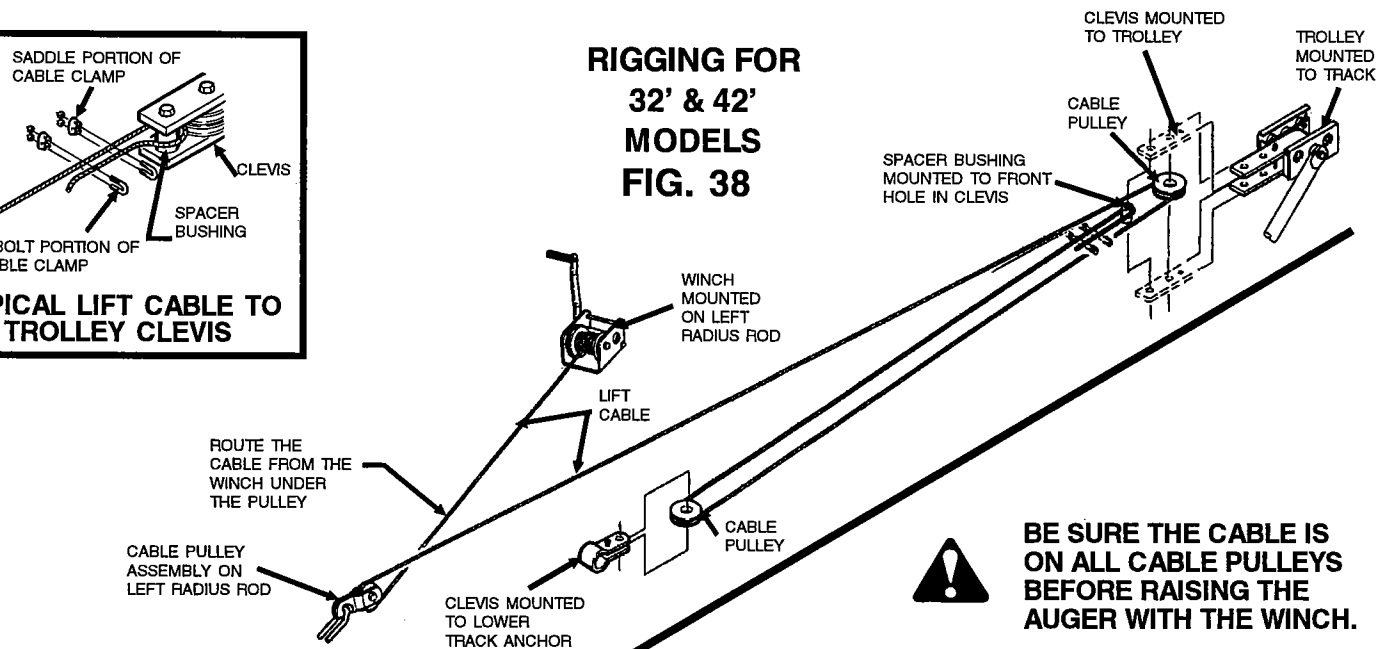


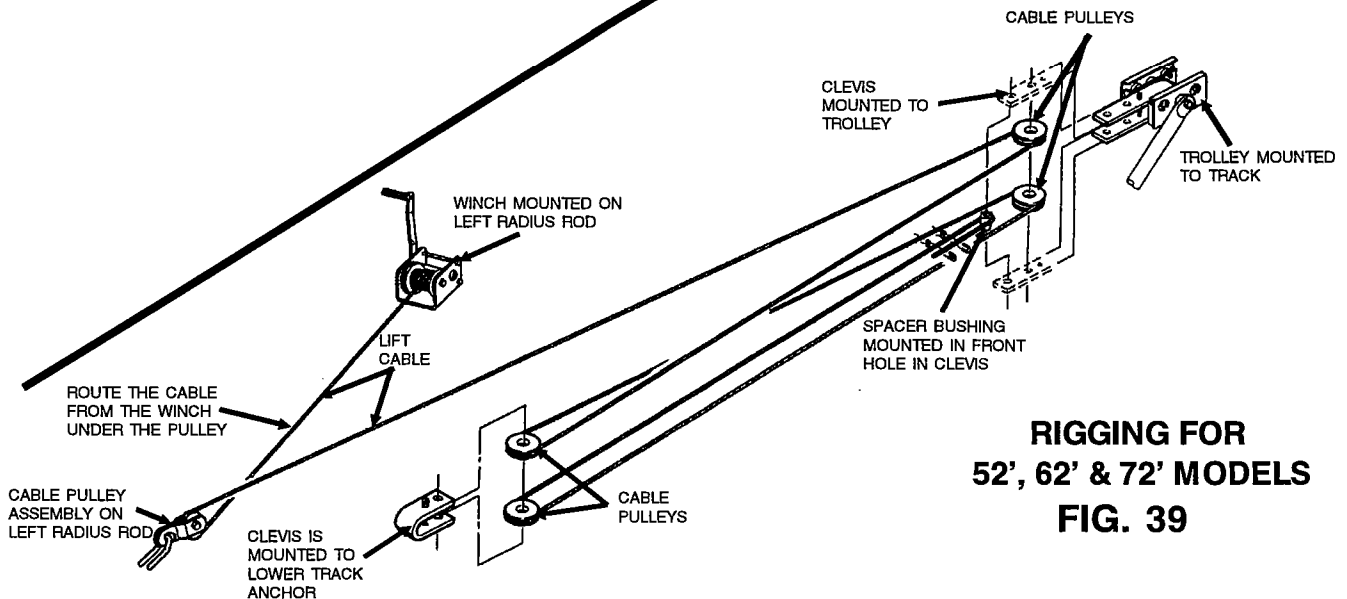
FIG. 37



RIGGING FOR 32' & 42' MODELS FIG. 38



BE SURE THE CABLE IS ON ALL CABLE PULLEYS BEFORE RAISING THE AUGER WITH THE WINCH.



RIGGING FOR 52', 62' & 72' MODELS FIG. 39

ASSEMBLY INSTRUCTIONS

TRACK, TRUSS AND GEAR UNDERCARRIAGE ASSEMBLY FOR HYDRAULIC LIFT UNDERCARRIAGE MODELS - (CONT.)

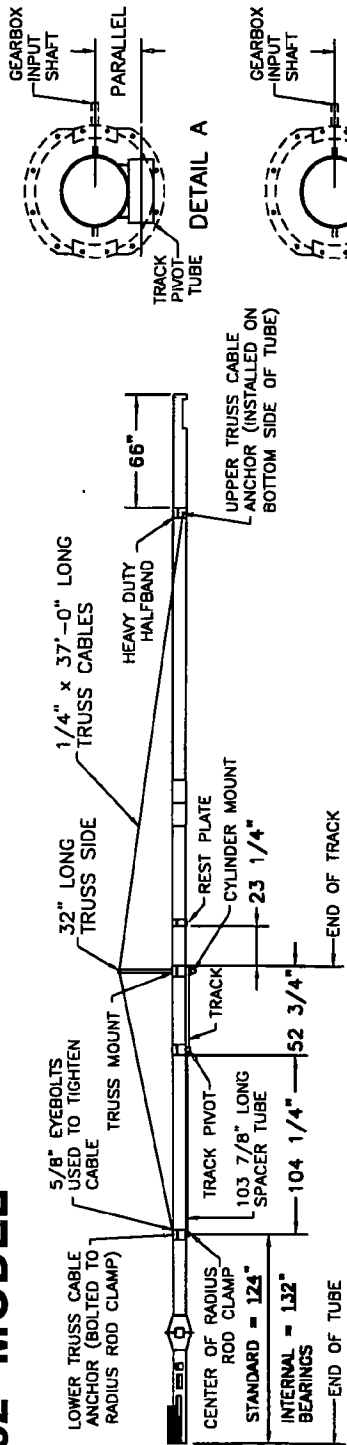
Pages 34 to 41 cover assembly for Hydraulic Lift Undercarriage Models Only.

Failure to locate components in the specified locations will cause the undercarriage to fail and the auger to fall, resulting in property damage, personal injury or death.

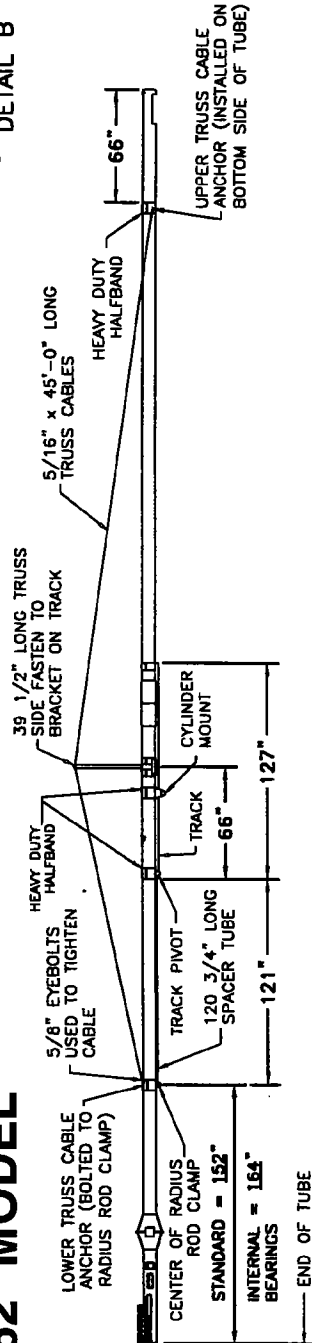


FIG. 40

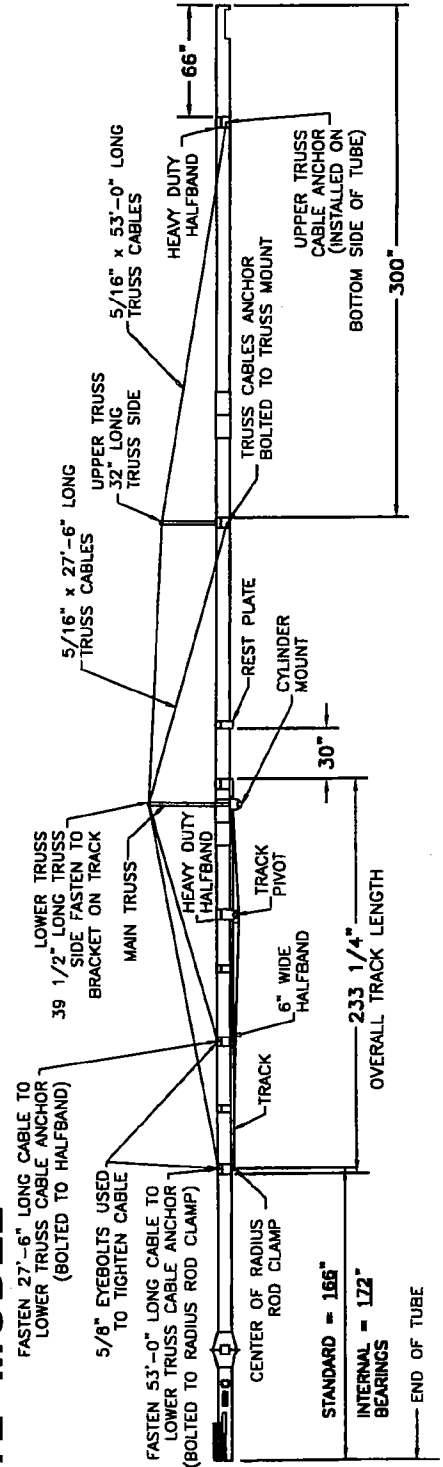
52' MODEL



62' MODEL



72' MODEL



ASSEMBLY INSTRUCTIONS

TRACK, TRUSS AND UNDERCARRIAGE ASSEMBLY FOR HYDRAULIC LIFT UNDERCARRIAGE MODEL - CONT.

See Fig. 40 on page 34 for location of track, truss and undercarriage components.



WARNING: The location of components that band to the auger tube is critical for proper operation of the undercarriage system. If the auger components you have do not match the lengths specified in these instructions or you cannot position the components where instructions specify due to interference with other items mounted on the auger tube, contact your dealer or the factory immediately. **DO NOT MODIFY** or **SUBSTITUTE** other components in an effort to complete the assembly of the auger.

Failure to position the components in the proper location will cause the undercarriage to fail and the auger to fall, resulting in property damage, personal injury or death.

TRACK AND RADIUS ROD CLAMP COMPONENTS

Step 1. Band the track to auger tube. When bolting the track to the auger tube, be sure to orientate so the track pivot center line and gearbox input shaft center line are parallel. See Detail A on page 34.

52' Models - Use one heavy duty halfband at lower end and one heavy duty halfband with truss mount at the upper end.

62' Models - Use two heavy duty halfbands and four 4" wide bands.

72' Models - Use two heavy duty halfbands with truss anchors on the lower end of the track, two heavy duty halfbands at the upper end of the track and two 4" wide bands.

NOTE: Use six 3/8" x 1 1/2" long (grade 5) hex head capscrews and nylon locknuts to secure heavy duty halfbands to track. Use four 5/16" x 1 1/2" long (grade 5) hex head capscrews and nylon locknuts to secure 4" wide halfbands to track.

Step 2. Fasten spacer tube to collar at lower end of track with one 5/16" x 1 3/4" long (grade 5) hex head capscrew and nylon locknut. See Detail C above (52' & 62' Models).

Step 3. Fasten radius rod clamp to spacer tube with one 5/16" x 1 3/4" long (grade 5) hex head capscrew and nylon locknut. When bolting the radius rod clamp to the auger tube, be sure the radius rod clamp and track pivot are parallel. See Detail B on page 34.

NOTE: 72' Models have the radius rod clamp as part of the track, therefore, a spacer tube is not required.

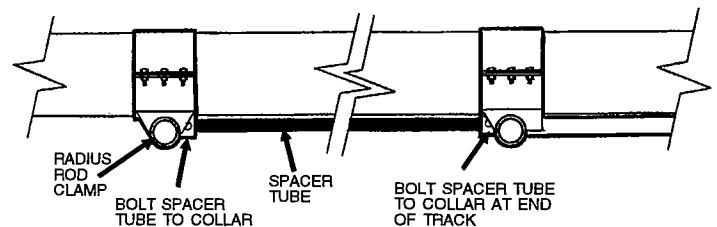
Step 4. Fasten radius rod clamp to the auger tube using a heavy duty halfband and six 3/8" x 1 1/2" long (grade 5) hex head capscrews with nylon locknuts. On 52', 62' and 72' models the heavy duty halfband will have truss anchors welded to it. The truss anchors must be positioned as shown in Fig. 43 on page 36.

Step 5. On 72' models another cable truss anchor has been attached to the top band of the track during Step 1. See Fig. 44 on page 36 for details.

Step 6. On 72' models fasten the upper truss mount to the tube using a heavy duty halfband (with truss cable anchors welded to it) and six 3/8" x 1 1/2" long (grade 5) hex head capscrews and nylon locknuts.

Step 7. Mount the upper truss cable anchors to auger tube using a heavy duty halfband and six 3/8" x 1 1/2" long (grade 5) hex head capscrews and nylon locknuts. NOTE: The upper truss cable anchor is mounted on the under side of the tube. See Fig. 45 on page 36.

Step 8. On 52' models fasten the undercarriage rest plates to the tube with a 4" wide halfband and four 3/8" x 1 1/2" (grade 5) hex head capscrews and nylon locknuts. See Fig. 40 on page 34 for location.



DETAIL C
52' & 62' MODELS

ASSEMBLY INSTRUCTIONS

TRACK, TRUSS AND UNDERCARRIAGE ASSEMBLY FOR HYDRAULIC LIFT UNDERCARRIAGE - CONT.

TRUSS COMPONENTS

See Fig. 40 on page 34 cable lengths, truss mounts and cable anchor locations.

Step 9. Loosely bolt truss sides to truss mount.

Step 10. Bolt the crossbrace(s) between the truss sides with two 3/8" x 1 1/4" long (grade 5) hex head capscrews and nylon locknuts.

Step 11. Tighten the hardware holding truss sides to truss mounts.

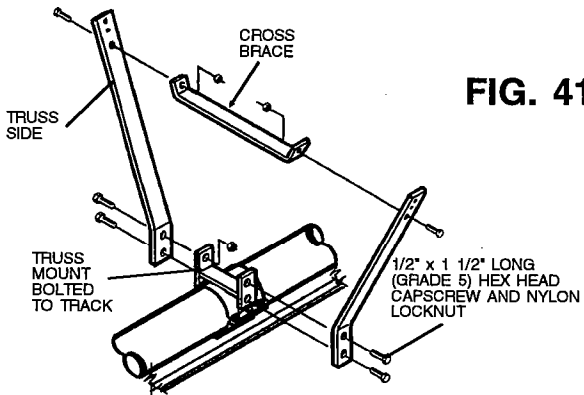


FIG. 41

**52' MODEL MAIN TRUSS
72' MODEL UPPER TRUSS**

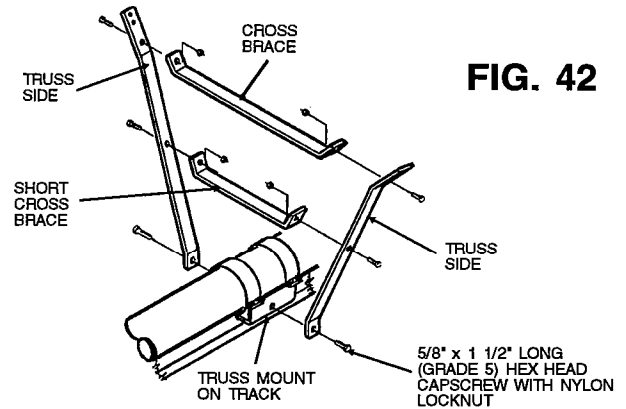


FIG. 42

**62' MODEL MAIN TRUSS (SHOWN)
72' MODEL LOWER TRUSS (SIMILAR)**

TRUSS CABLE RIGGING

Step 12. Install the eyebolts into the lower truss anchor with the eye toward the discharge end of the auger. Install two nuts on each eyebolt. The 52' and 62' models use two eyebolts. See Fig. 43. The 72' models use four eyebolts. See Fig. 44.

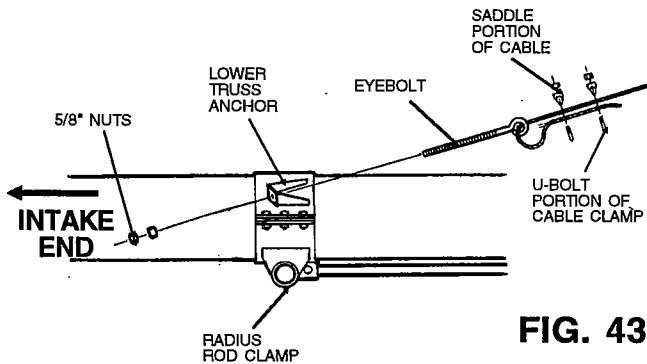


FIG. 43

**52' & 62' MODEL (SHOWN)
72' MODEL (SIMILAR)
LOWER CABLE ANCHOR DETAIL**

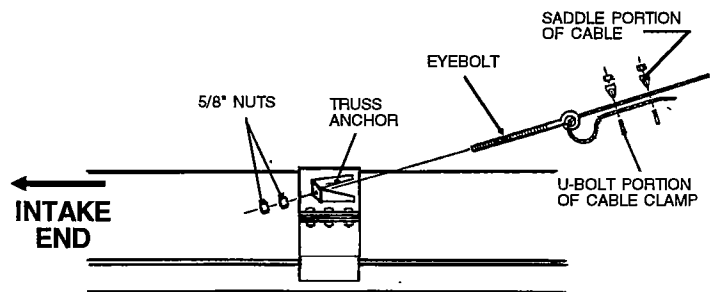


FIG. 44

**72' MODEL
MID CABLE ANCHOR DETAIL**

Step 13. Attach truss cables to upper cable anchors using two cable clamps per each cable. **NOTE:** Secure the clamp u-bolts against the loose end of the cable. See Fig. 45.

Step 14. Run the cables over the truss crossbraces, then toward the intake end of the auger. (The 72' models use two sets of cable. The long set will run over the upper truss then over the main truss. The short set of cables will run over the main truss then toward the intake end of auger and attach to mid cable anchor.)

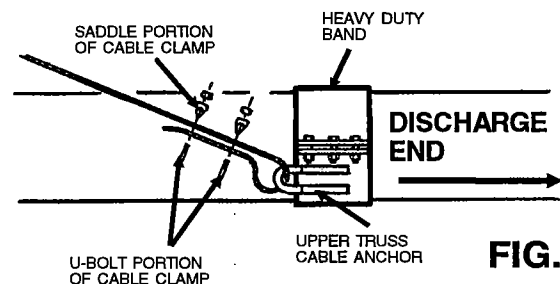


FIG. 45

UPPER TRUSS CABLE ANCHOR DETAIL

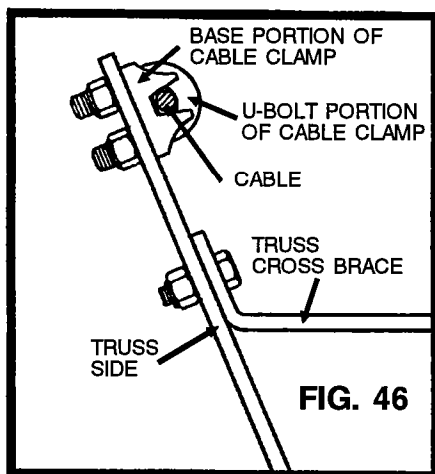
ASSEMBLY INSTRUCTIONS

TRACK, TRUSS AND UNDERCARRIAGE ASSEMBLY FOR HYDRAULIC LIFT UNDERCARRIAGE MODELS - CONT.

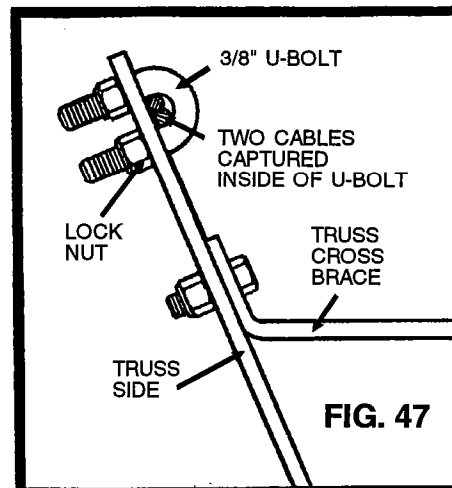
TRUSS CABLE RIGGING - CONT.

Step 15. Attach the cables to the truss sides. On 52' and 62' models and the upper truss for 72' models, use 3/8" cable clamp to fasten the cables to truss sides. See Fig. 46. On the lower truss for 72' models, use a 3/8" u-bolt and two locknuts to hold two cables to the truss side. See Fig. 47.

IMPORTANT: DO NOT tighten the 3/8" clamps and 3/8" u-bolts at this time. The cables must be able to freely slide through the clamps or u-bolts while taking up the slack in step 17.



**TRUSS CABLE TO TRUSS SIDE ON
52' & 62' MODELS AND THE
UPPER TRUSS ON 72' MODELS**



**TRUSS CABLE TO TRUSS SIDE ON
LOWER TRUSS ON 72' MODELS**

Step 16. Attach truss cables to eyebolts using two cable clamps per each cable. **NOTE:** Secure the clamp u-bolt against loose end of cable. See Fig. 43 and/or Fig. 44. on page 36

Step 17. Using eyebolts tighten cables until they are reasonably snug. Tighten cables the equally. **DO NOT OVERTIGHTEN.** Sight down the tube to make sure all sections are straight. Some adjustment can be made after auger is completely set up.

Step 18. Tighten the 3/8" cable clamps or 3/8" u-bolts holding the cable to the truss sides.

RADIUS ROD AND UNDERCARRIAGE FRAME COMPONENTS

See chart on page 38 to be sure that the undercarriage components are the correct length for the size of auger that is being assembled.

Step 19. Lay out the radius rods (with trussing and square plate). The flattened ends of the radius rods must be toward the intake end of the auger. When standing at the intake end and facing the discharge end of the auger, the radius rod with the winch mount must be on the left side. See Fig. 48 on page 38. Lay the undercarriage frame between the radius rods.

Step 20. Insert the pivot shaft on the undercarriage frame into the square plates welded to the radius rods. Insert and spread one 5/16" x 2" cotter pin in each pivot shaft to secure in place.

Step 21. Slide the axle shaft through the pipes on the ends of the radius rods. The hubs, bearings, seals and spindles are assembled at the factory and are pressure packed with grease at that time. Slide the hub and spindle assembly into the undercarriage axle and secure with a hex head capscrews and nylon locknut. Model 52' uses 1/2" x 3 1/4" long (grade 5) hex head capscrew and models 62' & 72' use 1/2" x 3 3/4" long (grade 5) hex head capscrews.

Step 22. Secure tire and rim to hub with lug bolts.

ASSEMBLY INSTRUCTIONS

TRACK, TRUSS AND UNDERCARRIAGE ASSEMBLY FOR HYDRAULIC LIFT UNDERCARRIAGE MODELS - (CONT.)

UNDERCARRIAGE COMPONENTS

Model	52'	62'	72'
A - Axle Length	94 1/2"	93"	120"
B - Radius Rod Length	146"	176 3/4"	209 1/4"
C - Undercarriage Frame	88 1/2"	102 3/4"	115"
D - H-Frame (Center to Center of Holes)	19 1/4"	19 1/4"	26 5/8"
E - H-Frame Tubes (Overall Length)	64 1/2"	82 1/2"	97"
F - Cylinder Size	4" Bore x 24" Stroke	4" Bore x 24" Stroke	4" Bore x 36" Stroke

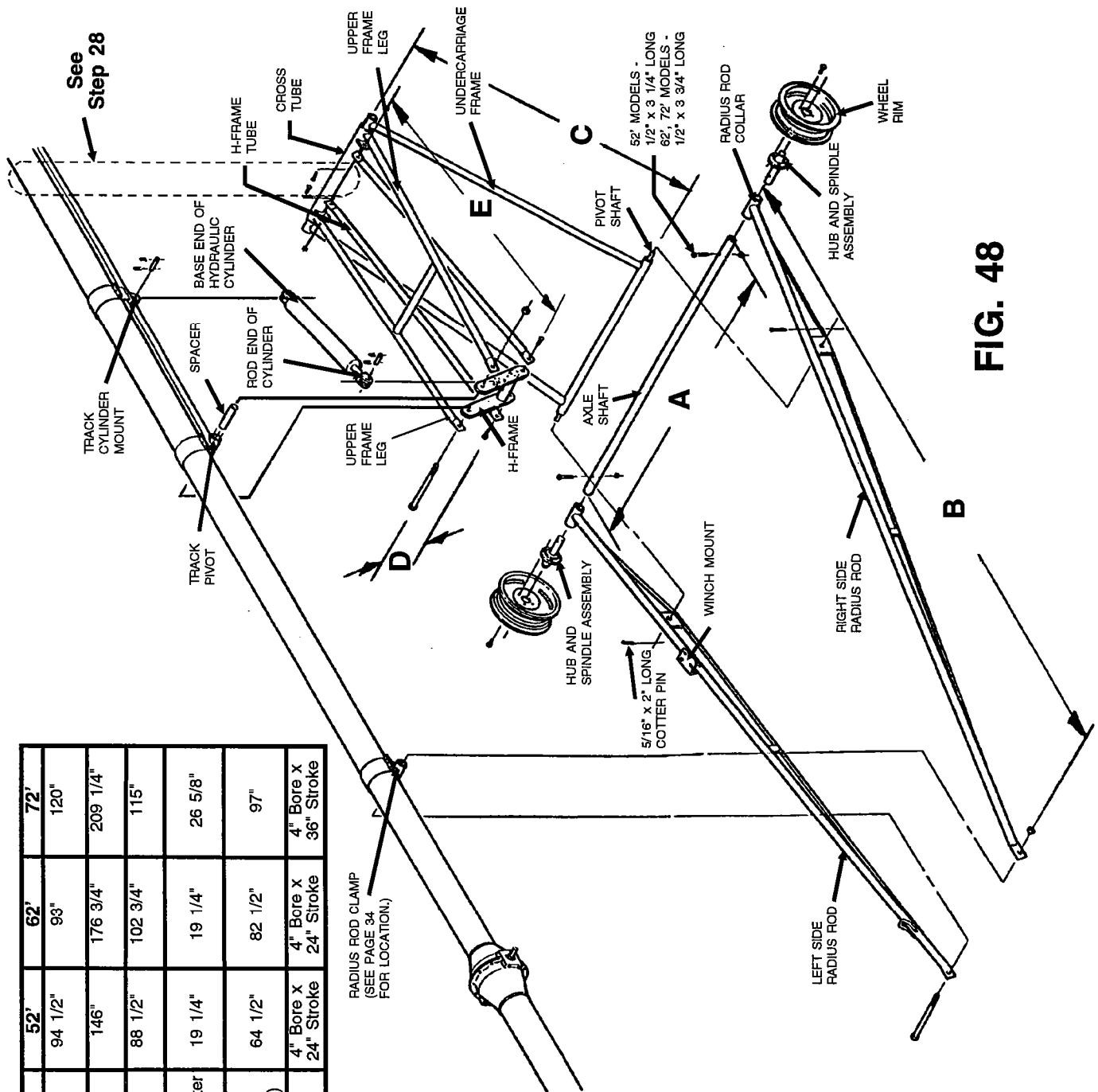


FIG. 48

ASSEMBLY INSTRUCTIONS

TRACK, TRUSS AND UNDERCARRIAGE ASSEMBLY FOR HYDRAULIC LIFT UNDERCARRIAGE - CONT.

RADIUS ROD AND UNDERCARRIAGE FRAME COMPONENTS - CONT.

- Step 23. Lift the discharge end of the auger tube with adequate hoist, attaching it about 2/3 of the way from the intake end of the auger. Raise the tube about 6'. Roll the undercarriage into position under the auger tube.
- Step 24. Insert the pivot spacer bushing into track pivot (welded at the lower end of the track).
- Step 25. Lift the upper undercarriage frame legs and bolt the "H" frame and upper legs to the track pivot using a 1" x 11" long (grade 5) hex head capscrew and nylon locknut on 52' & 62' models or 1" x 12" long (grade 5) hex head capscrew and nylon locknut on 72' models. See Fig. 49.
- Step 26. Bolt the "H" frame tubes to the lower end of the "H" frame with 3/4" x 2" long (grade 5) hex head capscrews and nylon locknuts.
- Step 27. Fasten the other end of "H" frame tubes to the ears on the undercarriage crosstube with 3/4" x 2" long (grade 5) hex head capscrews and nylon locknuts.
- Step 28. Wrap a chain or heavy duty strap around the auger tube and undercarriage frame. Chain or strap must be tight to keep the undercarriage from opening when the tube is raised to connect the radius rods to radius rod clamp. See Fig. 48 on page 38.
- Step 29. Lift the auger with the hoist high enough to line up the radius rods with radius rod clamp.
- Step 30. Insert the pivot pipe spacer into the pipe on the radius rod clamp. Then insert a 3/4" x 11" long (grade 5) hex head capscrew through a flat washer, one radius rod, a spacer and then the other radius rod and a nylon locknut. See Fig. 50. **NOTE:** Check to see all undercarriage bolts and fasteners are tight and assembled correctly.
- Step 31. Before releasing the hoist and with the intake on the ground, check the transport height of the auger in full down transport position (with the trolley touching the down stop) by measuring the distance from the top of the auger tube (at the discharge end) to the ground. Use the transport height chart on page 5 to check your measurement. If your measurement does **NOT** fit into the range on the chart for your size auger, then go back and check the following items:

- Location of radius rod clamp and track - See page 34.
- The length of undercarriage components - See page 38.
- The length of auger tubes - See page 18.
- Is the discharge end of auger tube sagging because the truss cables require tightening? - See step 17 on page 37.

If you have checked all of the above items and your measured discharged height is **NOT** in the range specified in the transport height chart, call your dealer or the factory immediately. **DO NOT CONTINUE TO ASSEMBLE THE AUGER** and do not release the hoist with the auger in this condition.

- Step 32. When the height of the auger is correct as described in step 31, the hoist may be released.

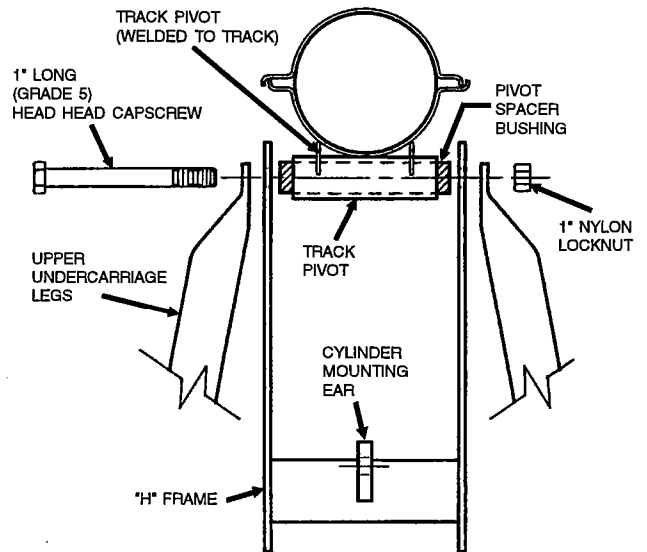


FIG. 49

TURN "H" FRAME SO CYLINDER MOUNTING EAR POINTS TOWARD AUGER DISCHARGE END.

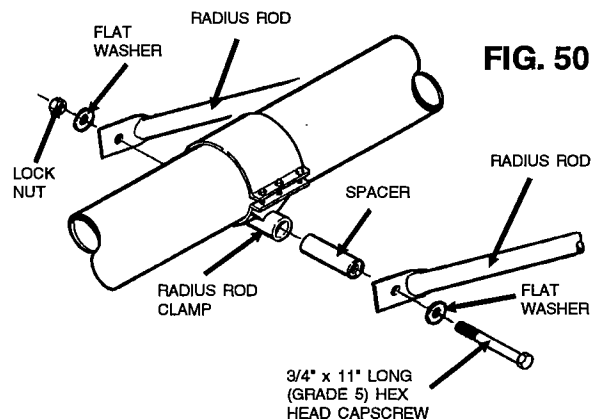


FIG. 50

ASSEMBLY INSTRUCTIONS

TRACK, TRUSS AND UNDERCARRIAGE ASSEMBLY FOR HYDRAULIC LIFT UNDERCARRIAGE MODELS (CONT.)

Step 33. Attach the hydraulic cylinder provided to the "H" frame as shown using mounting pin and keeper clip furnished in box with cylinder. The base end of the cylinder must be attached to mount on the track. The rod end of the cylinder will be attached to the mount on the "H" frame. The cylinder ports must be facing the left side of the auger when viewing the auger from the intake end.

IMPORTANT: The cylinder furnished with your auger has a restrictor in the port at the base end of the cylinder. This restrictor limits the speed the auger is raised or lowered. Use only the cylinder provided with the auger. Do not use a cylinder that does not have the proper restrictor.

HYDRAULIC HOSE COMPONENTS

Step 34. Thread the heavy duty street el into the cylinder port at the base. See Fig. 51. Tighten and leave street el parallel with auger tube and pointed toward intake end. Attach the swivel end of the hydraulic hose to the street el and tighten.

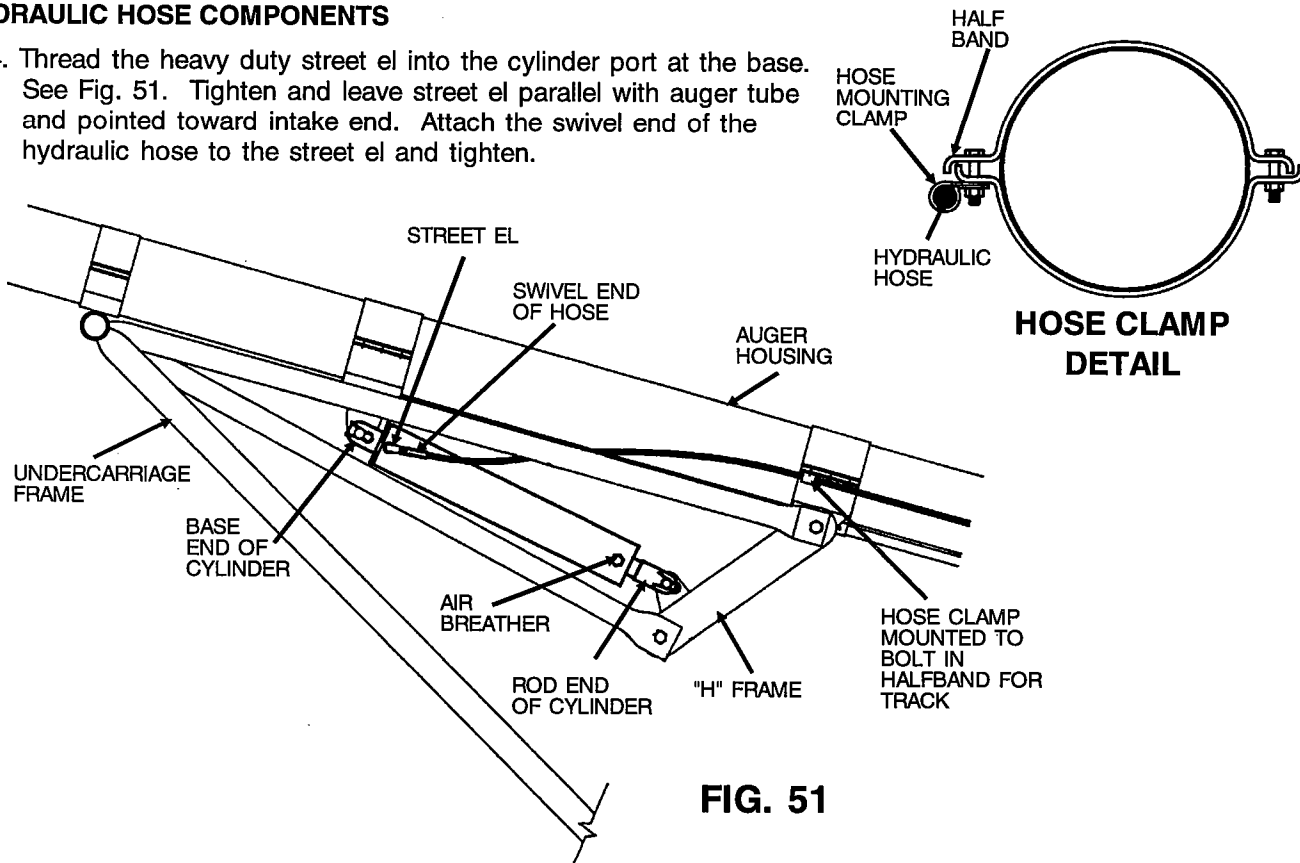


FIG. 51

Step 35. Starting at the cylinder end of the hose, fasten the hydraulic hose to the auger housing using hose mounting clamps attached to various halfbands along the tube. See Fig. 52 on page 41 for the location of the hose clamps.

Step 36. Thread the shut-off valve onto the end of the hose. When installed, the arrow on the valve must point towards the auger and away from the tractor. The hose should be threaded into the female end of the valve.

Step 37. Check all fittings and connections to see if tight.



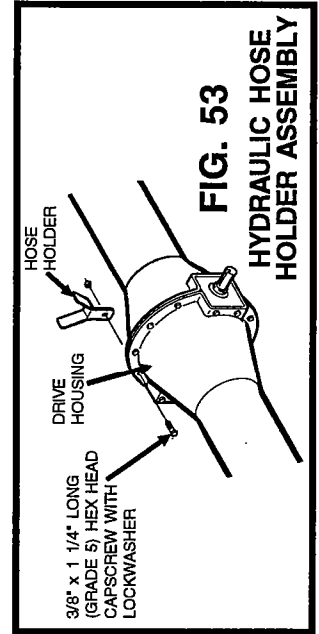
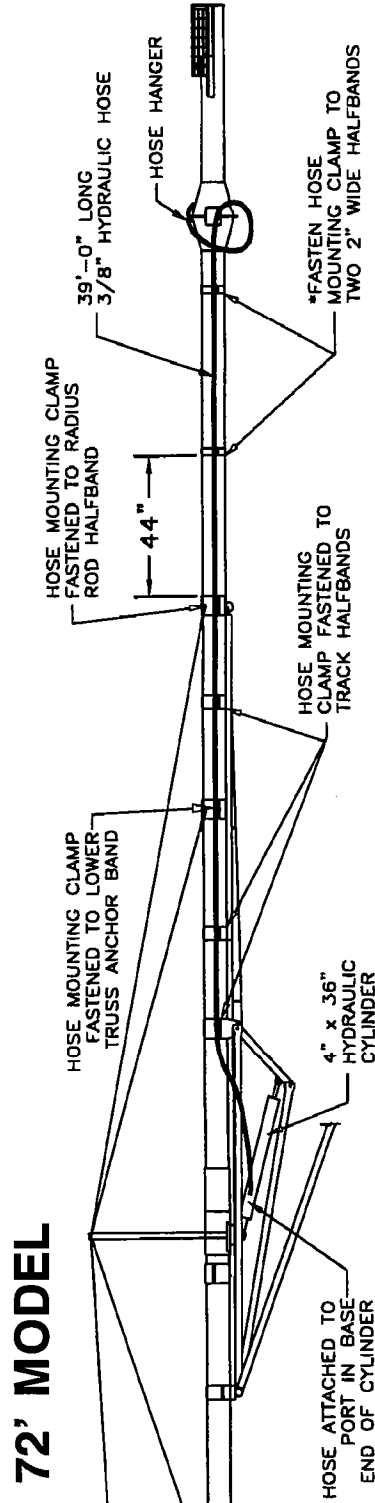
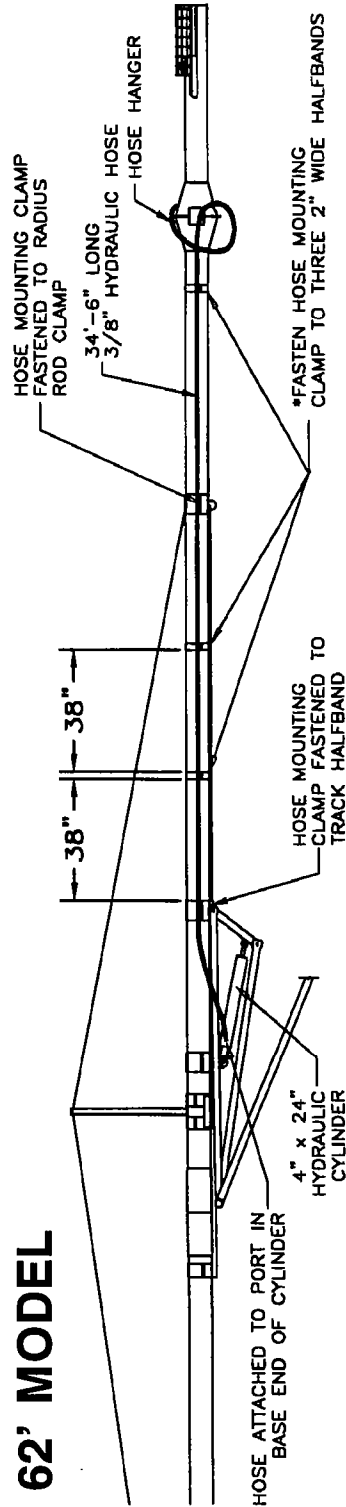
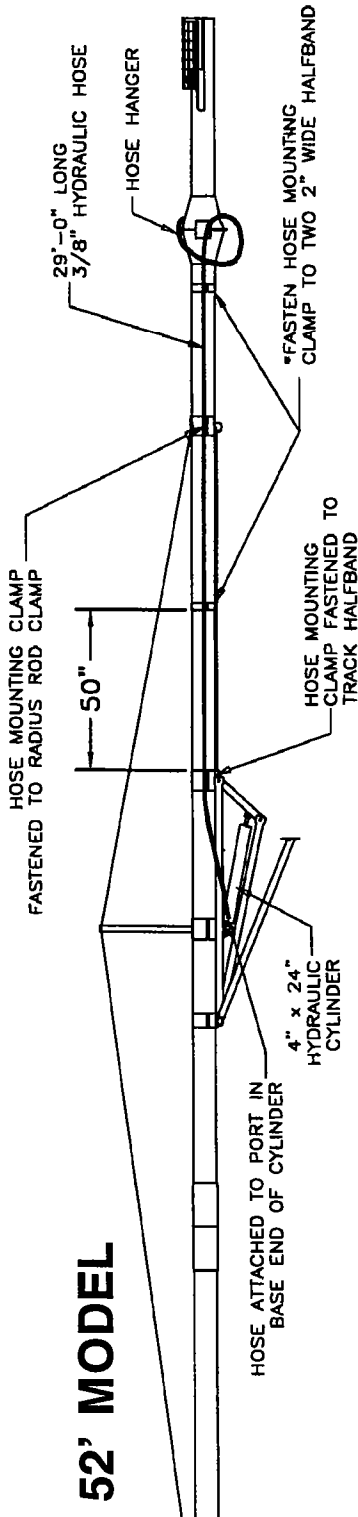
CAUTION: Do not connect or disconnect hydraulic components when there is pressure within the system. Hydraulic systems are highly pressurized. Escaping hydraulic oil, even an invisible pinhole leak, can penetrate body tissues and cause serious injury. Use a piece of wood or cardboard when looking for leaks. Never use the hands or other parts of the body. When reassembling, make absolutely certain that all connections are tight. If injured by hydraulic oil escaping under pressure, see a doctor immediately. Serious infection or reaction may occur if medical attention is not received at once.

Step 38. Fasten the hydraulic hose holder to drive housing using a 3/8" x 1 1/4" long (grade 5) hex head capscrew and lockwasher. See Fig. 53 on page 41.

ASSEMBLY INSTRUCTIONS

TRACK, TRUSS AND UNDERCARRIAGE ASSEMBLY FOR HYDRAULIC LIFT UNDERCARRIAGE MODELS - (CONT.)

HYDRAULIC HOSE CLAMP LOCATIONS



***NOTE: 2" wide halfbands are secured to tube by using (two) 5/16" x 1 1/2" long (grade 5) hex head capscrows and nylon locknuts**

ASSEMBLY INSTRUCTIONS

DRAIN HOLE COVER

Install the drain hole cover using two 5/16" x 3/4" carriage bolts with a locknut for the pivot hole and a wing nut for the slot. See Fig. 54.

HITCH TO INTAKE

Attach hitch to tube attachment anchor with one 1/2" x 3" long hex head capscrew (grade 5), lockwasher and nut. See Fig. 55.

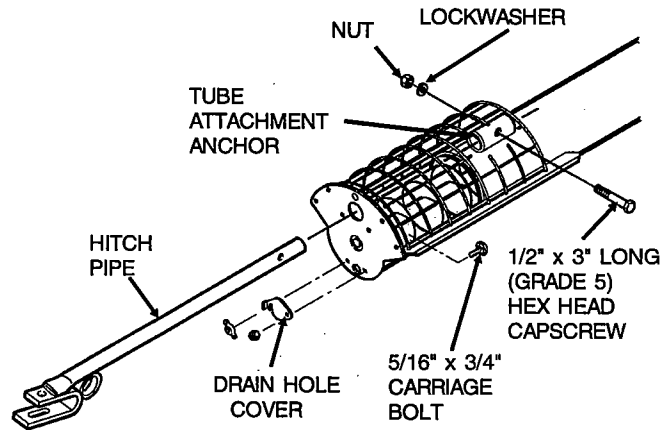


FIG. 54

OPERATOR'S MANUAL CONTAINER

1. Check that an Operator's Manual is in the plastic container.
2. Snap the container into holder located on the left radius rod arm. See Fig. 55.

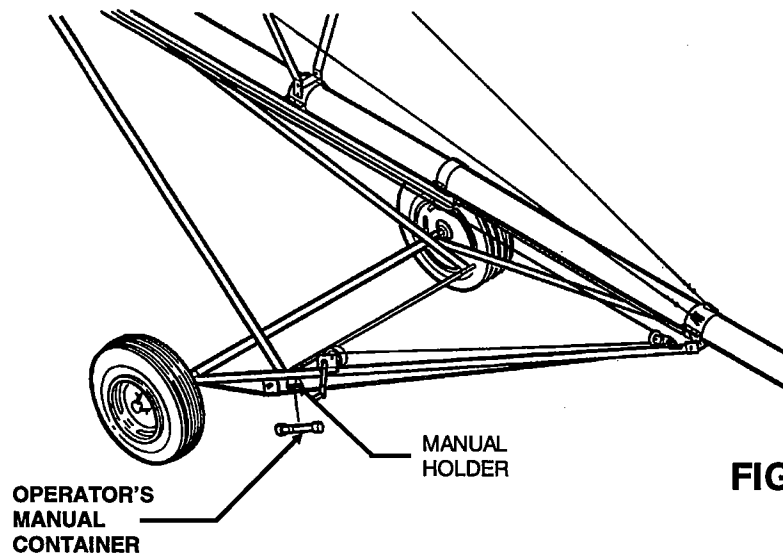


FIG. 55

BLOW-OFF CAP

1. Attach chain to the hole in the top of the tube, located at the discharge end of the auger using a 1/4" x 3/4" long hex head capscrew and 1/4" nylon locknut.
2. Attach the other end of the chain into the hole of the cap using a 1/4" x 3/4" long hex head capscrew and 1/4" nylon locknut.
3. Slide cap over end of tube. The cap should fit snugly, but be able to slide off the end of the tube if discharge should become plugged. Push the cap off to verify fit and then reinstall. It should be possible to tap the cap off by hand.

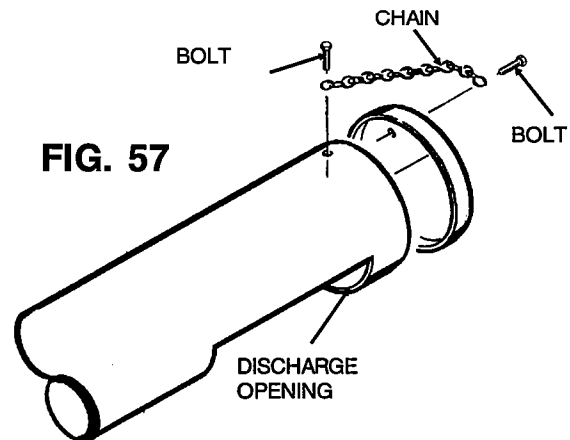


FIG. 57

ASSEMBLY INSTRUCTIONS

ELECTRIC MOTOR DRIVE ASSEMBLY

NOTE: The gearbox input shaft must be located on the right hand side of the auger housing for the electric drive to be assembled. Refer to Fig. 58.

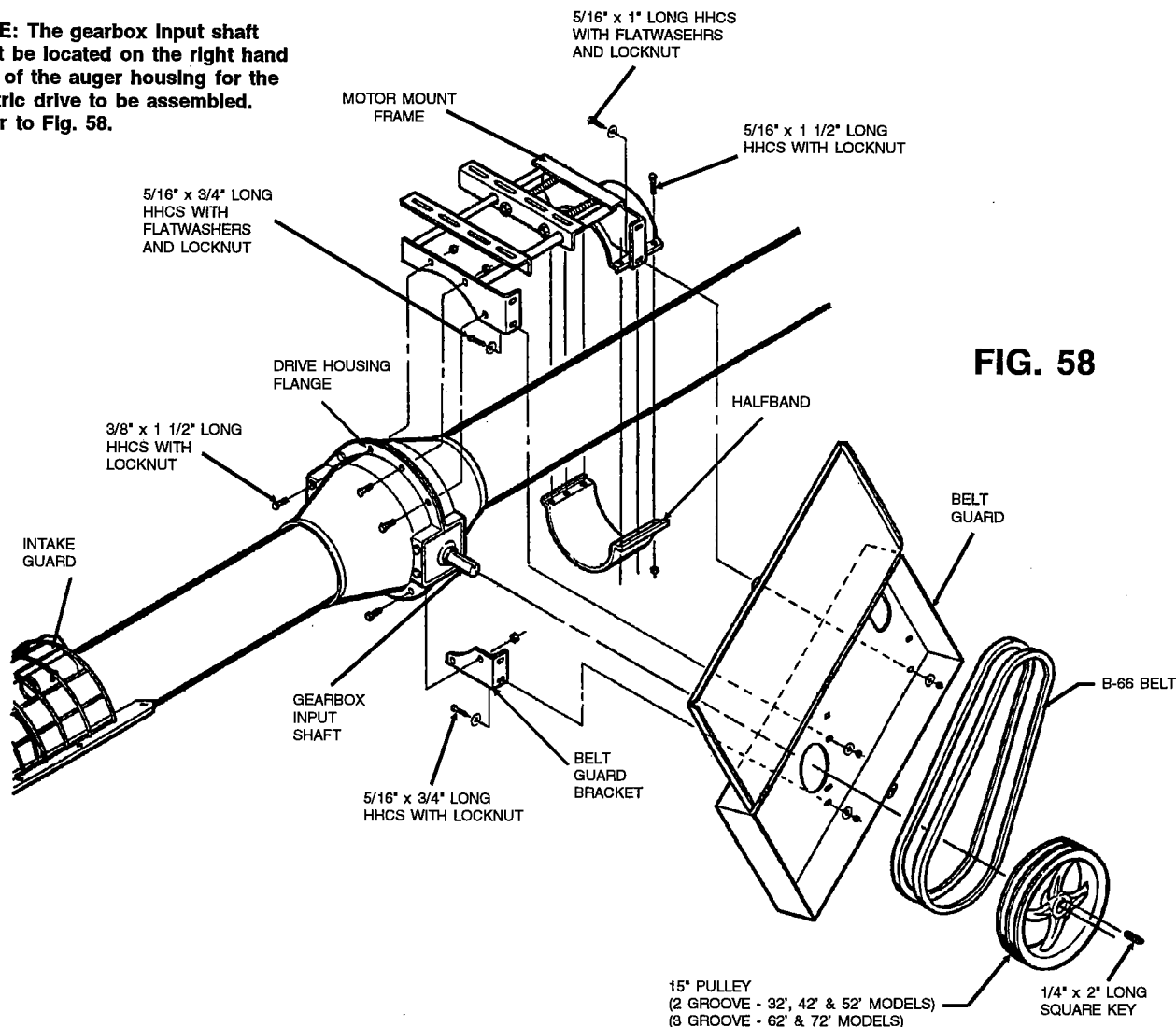


FIG. 58

1. Fasten front end of motor mount frame to drive housing flange with three 3/8" x 1 1/2" long hex head capscrews (grade 5) and nylon locknuts.
2. Attach back end of motor mount frame to auger tube with a heavy duty halfband and six 5/16" x 1 1/2" long hex head capscrews (grade 5) and nylon locknuts.
3. Fasten belt guard bracket to drive housing flange with two 3/8" x 1 1/2" long hex head capscrews (grade 5) and nylon locknuts.
4. Bolt belt guard to brackets on motor mount frame with four 5/16" x 1" long hex head capscrews (grade 5), flat washers and nylon locknuts.
5. Bolt belt guard to belt guard bracket that is bolted to drive housing. Use two 5/16" x 3/4" long (grade 5) hex head capscrews, flat washers and nylon locknuts.
6. Install motor. It is important to use the recommended size and speed. See page 11 for specifications.
7. Install sheave on motor shaft. (Motor sheave not furnished. See page 11.)
8. Install 15" O.D. sheave onto gearbox input shaft with 1/4" square drive key. **NOTE: Tighten setscrews in hub** to secure sheave to gearbox shaft.
9. Align sheaves by using a straight edge placed across the outer faces of both sheaves.
10. Install and tighten belts. Use the adjustment bolts in the end of the motor mount. Adjustment bolts should be turned equally to prevent binding.

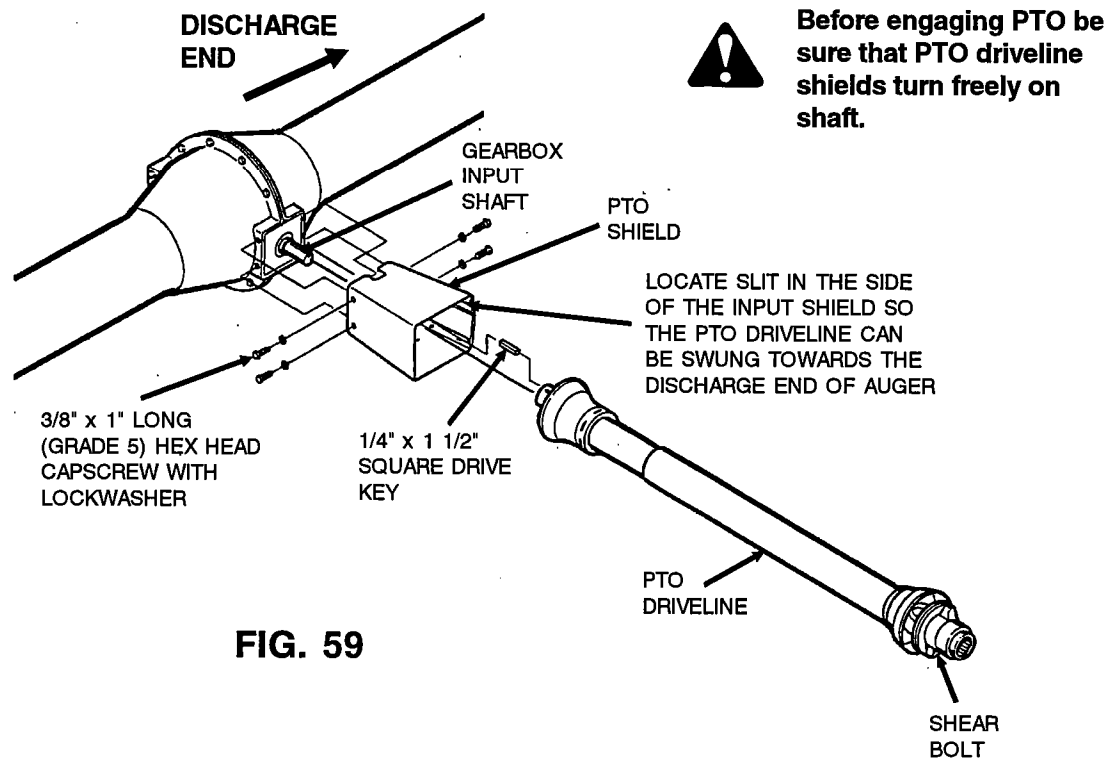
ASSEMBLY INSTRUCTIONS

P.T.O. DRIVE ASSEMBLY

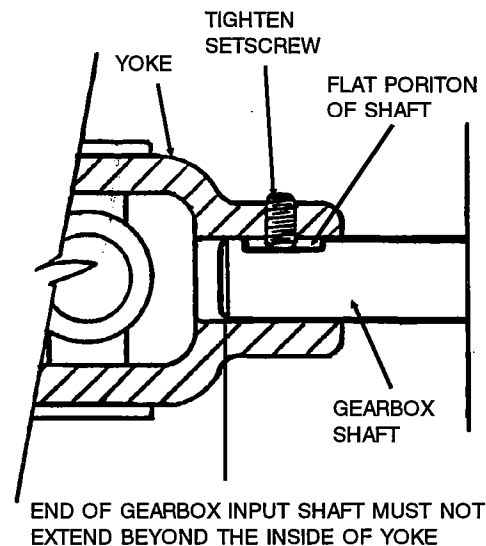
The PTO drive can be installed on either the right or left hand side of the auger.

⚠ Care should be taken when changing drive from one side of the auger to the other side. To avoid dangerous situations, follow changeover instructions on page 45.

Step 1. Attach PTO driveline to gearbox input shaft by using 1/4" x 1 1/2" long square drive key. See Fig. 59. Place setscrews properly, then tighten. See Fig. 60.



IMPORTANT: For setscrew to be properly engaged on the gearbox input shaft, the gearbox input shaft **MUST** be slid into the PTO driveline yoke until the setscrew will sit on flat portion of shaft. (See Fig. 60.) Do not extend the gearbox input shaft beyond the inside end of the yoke.



ASSEMBLY INSTRUCTIONS

PTO DRIVE ASSEMBLY - CONT.

Step 2. Remove two 3/8" x 1" long (grade 5) hex head capscrew that hold gearbox mounting ear to drive housing.

Step 3. Slide input shield over the PTO driveline and fasten to the drive housing using two 3/8" x 1" long (grade 5) hex head capscrews with lockwashers. See Fig. 59 on page 44.

NOTE: Locate the slit in the rubber on the input shield so the PTO driveline can be swung towards the discharge end of the auger for storage during transport as shown.

Step 4. Place the PTO driveline support 51" from the center of the gearbox (toward the discharge end of the auger). Secure that support to the tube with a halfband and two 5/16" x 1 1/2" long (grade 5) hex head capscrews and nylon locknuts. See Fig. 61.

IMPORTANT: Do not install the support where the bands will cover any safety signs on the auger housing.

Step 5. Set PTO driveline into the support to be sure the support is installed properly.

Step 6. Install the retaining pin by slipping the short bend end of pin through hole in PTO driveline support and through slot on the other side. Allow long end of pin to rotate down, this will secure pin in place.

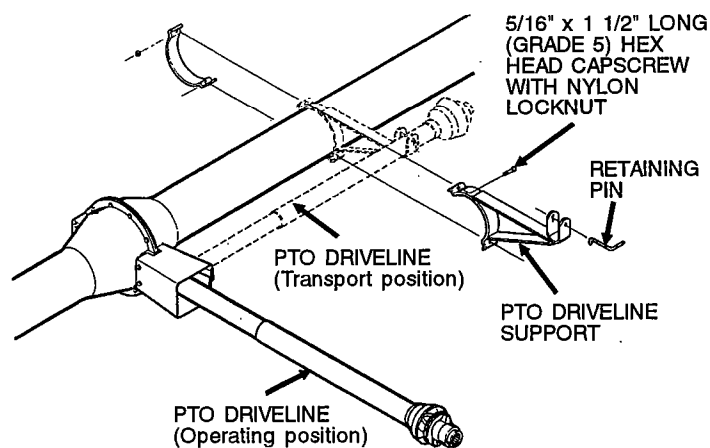


FIG. 61

PTO DRIVE CHANGEOVER INSTRUCTIONS

Step 1. Disconnect PTO driveline from tractor.

Step 2. Remove the input shield from drive housing.

Step 3. Follow the Drive Housing Disassembly Instructions, on the following page so gearbox can be unbolted from the drive housing halves. **IMPORTANT: Observe all precautions listed on page 46.**

Step 4. Slide the drive housing apart so gearbox can be rotated 180°.

Step 5. The filler/vent elbow on the gearbox mounting ear must be rotated so it is pointing up.

Step 6. Bolt gearbox to drive housing halves and the drive housing flanges together.

Step 7. Install the input shield to cover the PTO driveline to gearbox shaft connection. See Fig. 59 on page 44.

Step 8. Remount the PTO driveline support onto the other side of the tube. See Fig. 61 above.

DRIVE HOUSING DISASSEMBLY INSTRUCTIONS

If the drive housing must be disassembled, for example, to repair the gearbox and flight or to change drive from one side of the auger to the other, carefully follow the steps below to avoid dangerous situations.

1. Disconnect power source from the auger.
2. Auger must be in full down transport position.
On Manual Lift Models - The trolley seated against the down stop.
On Hydraulic Lift Models - The auger tube seated on the undercarriage crossbrace.
3. Support the discharge end of auger, either with overhead hoist to hold the auger up or a suitable structure under the auger to prevent it from upending when drive housing is disassembled and intake end of housing is removed.
4. Block just above the drive housing so the intake end is 4" to 6" above the ground.
5. Disassemble drive housing halves to gain access to gearbox and flight. On electric drive models, the auger sheaves, belts and belt guard must be removed before drive housings can be disassembled.
IMPORTANT: Be sure the auger is completely reassembled before removing any supports.

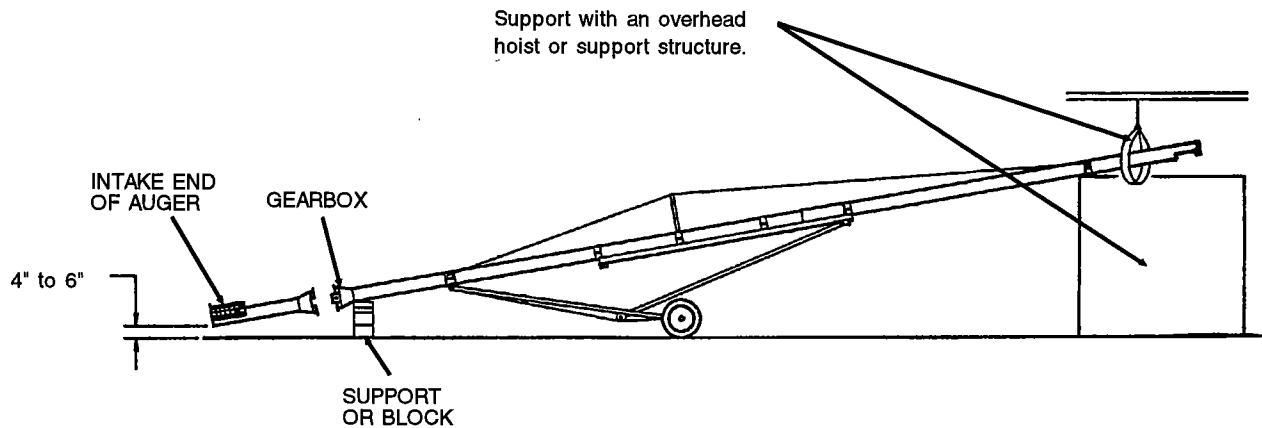


FIG. 62

TO DEALER/ASSEMBLER NOTICE

The assembly of the auger is complete if all the applicable assembly steps in this manual have been followed.

Before delivery to the owner it is a good practice to check the following:

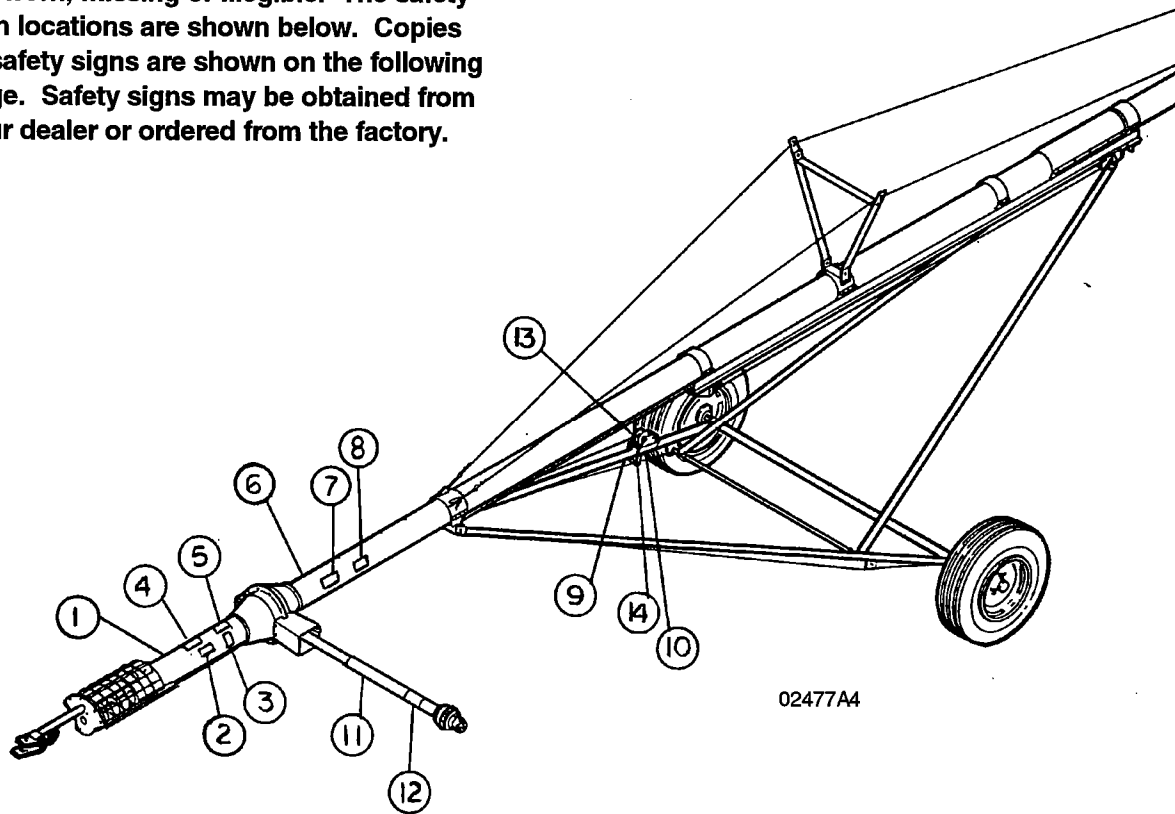
- a. Be sure all safety shields and devices are installed properly.
- b. Check all safety decals to see if they are clean and readable. If any are missing, damaged, painted over, etc. replace them. See page P-1 & P-2 for safety sign location. Decals may be obtained from your dealer or ordered from the factory.
- c. Check all bolts and fasteners to see they are tightened and secured properly.
- d. Check that the Operator's Manual container (with Operator's Manual inside) is installed in its holder located on the left radius rod.

Deliver this Assembly and Operator's Manual to the owner along with the auger.

8" INLINE/MID-DRIVE

SAFETY SIGNS AND DECALS

Check all safety signs and replace any that are worn, missing or illegible. The safety sign locations are shown below. Copies of safety signs are shown on the following page. Safety signs may be obtained from your dealer or ordered from the factory.

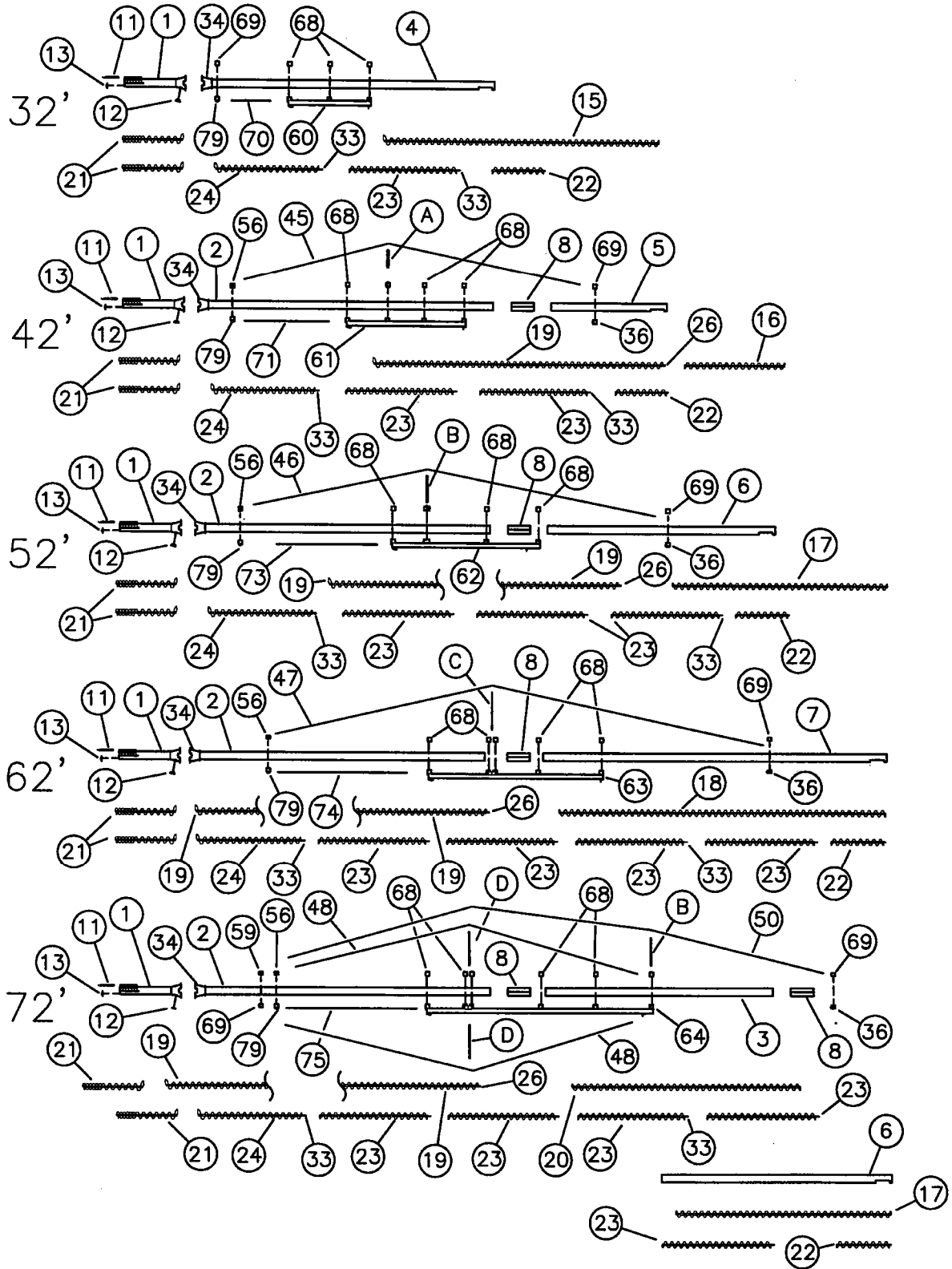


REF.	PART NO.	DESCRIPTION	SIZE
1	1001973	CAUTION - GENERAL STATEMENTS 1-8 DECAL	4 3/4" x 8"
2	1001980	DANGER - BEWARE OF POWER LINES DECAL	4" x 8"
3	1001983	DANGER - ROTATING DRIVE LINE DECAL	4 1/2" x 6 1/4"
4	1001985	DANGER - ROTATING AUGER DECAL	4 1/2" x 6 1/4"
5	1001981	DANGER - UPENDING HAZARD DECAL	4 1/2" x 6 1/4"
6	1001974	WARNING - ESCAPING HYDRAULIC OIL DECAL	4" x 7 1/4"
7	1007857	DANGER - DISASSEMBLY HAZARD DECAL	4" x 8"
8	1005325	DANGER "STOP" IF ANY GUARDS, SHIELDS	4" x 6"
9	1002091	WARNING HAND WINCH OPERATION	2 3/4" x 5"
10	1004461	OPERATOR'S MANUAL INSIDE DECAL	1 1/2" x 7 1/2"
11	13-10022	DANGER - SHIELD MISSING Under PTO Driveline Shield	--
12	13-10021	DANGER - ROTATING DRIVE LINE On PTO Driveline Shield	--
13	1002805	CAUTION - CABLE OUT/CABLE IN On Winch Body	--
14	2169A1	CAUTION - WINCH OPERATION On Hand Winch Handle	--
Not Shown	1001926	DANGER - CYLINDER STATEMENT On one side of Hydraulic Cylinder (Hydraulic Lift Models)	4" x 8"

8" INLINE/MID-DRIVE

MAIN AUGER COMPONENTS FOR MANUAL LIFT UNDERCARRIAGE UNITS

NOTE: Reference letters designate detail views shown on page P-7.

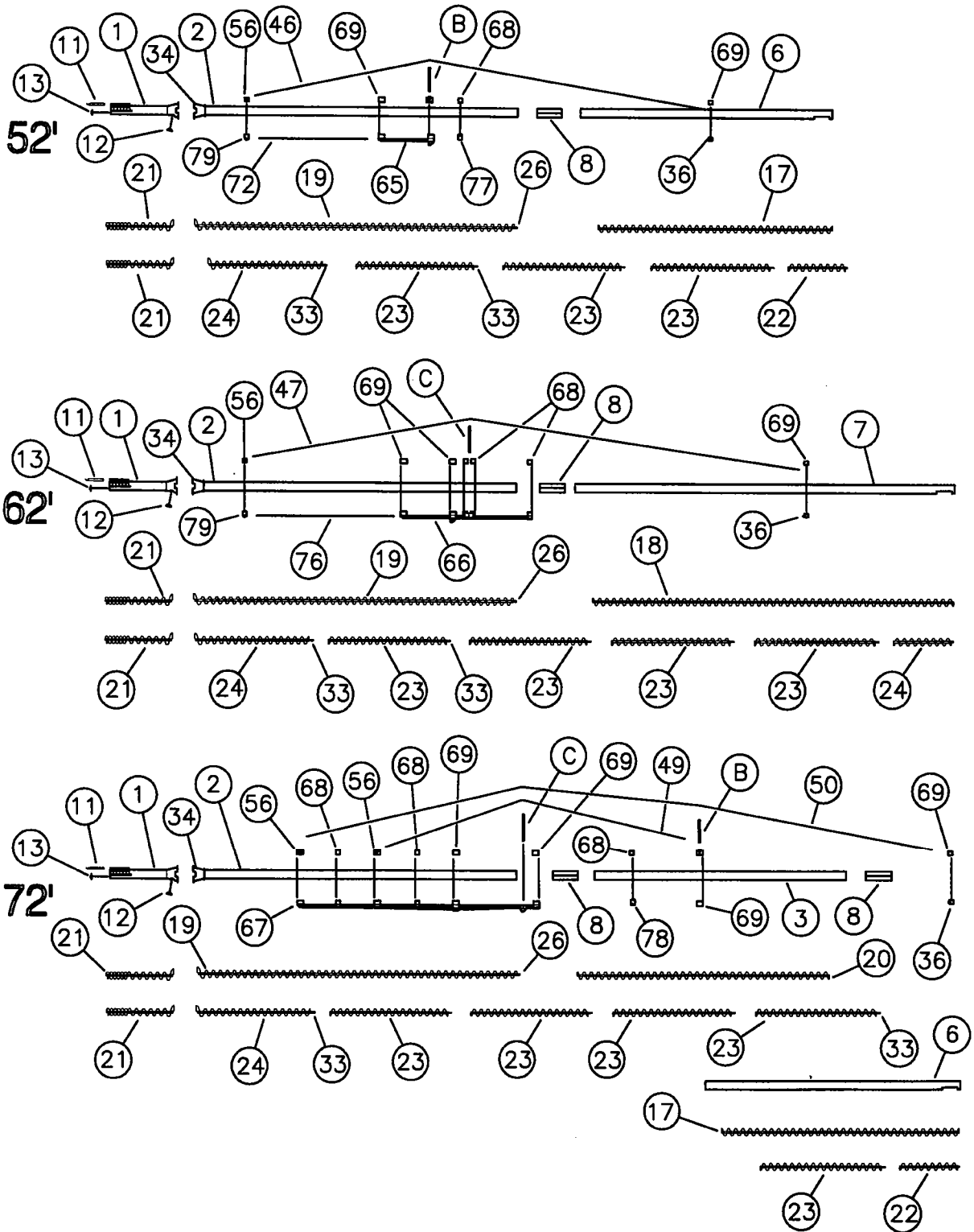


8" INLINE/MID-DRIVE

Page P-4

MAIN AUGER COMPONENTS FOR HYDRAULIC LIFT UNDERCARRIAGE UNITS

NOTE: Reference letters designate detail views shown on page P-7.



8" INLINE/MID-DRIVE

MAIN AUGER COMPONENTS

(Parts listed below are shown on pages P-3 & P-4.)

MAYRATH HOUSINGS

REF. NO.	PART NO.	DESCRIPTION
1	1013335-120	Tube Housing - Lower w/Intake Guard
--	8379C	Bronze Bushing (1 1/4" Bore)
2	---	Tube Housing - Center
	1018027-120	f/42', 52', 62' & 72' (25' long)
	1018033-120	f/52' w/Corn Screens (25' long)
	1018034-120	f/62' w/Corn Screens (25' long)
3	1013348-120	Tube Housing - Middle f/72' (20' long)
4-7	---	Tube Housing - Upper
4	1018035-320	f/32' (25'-0" long)
5	1013351-320	f/42' (10'-0" long)
6	1013350-320	f/52' & 72' (20'-0" long)
7	1013349-320	f/62' (30'-0" long)
34	1018014	Upper Drive Housing

HUTCHINSON HOUSINGS

REF. NO.	PART NO.	DESCRIPTION
1	1013335-120	Tube Housing - Lower w/Intake Guard
--	8379C	Bronze Bushing (1 1/4" Bore)
2	---	Tube Housing - Center
	1018027-120	f/42', 52', 62' & 72' (25' long)
	1018033-120	f/52' w/Corn Screens (25' long)
	1018034-120	f/62' w/Corn Screens (25' long)
3	1013348-120	Tube Housing - Middle f/72' (20' long)
4-7	---	Tube Housing - Upper
4	1018035-220	f/32' (25'-0" long)
5	1013351-220	f/42' (10'-0" long)
6	1013350-220	f/52' & 72' (20'-0" long)
7	1013349-220	f/62' (30'-0" long)
34	1018014	Upper Drive Housing

MAYRATH HOUSINGS FOR INTERMEDIATE BEARINGS

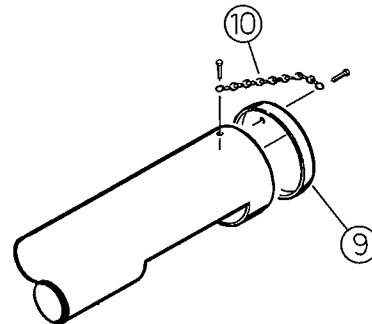
REF. NO.	PART NO.	DESCRIPTION
1	1013335-120	Tube Housing - Lower w/Intake Guard
--	8379C	Bronze Bushing (1 1/4" Bore)
2	---	Tube Housing - Center
	1018036-120	f/42', 52', 62', 72' (25' long)
	1018037-120	f/52' w/Corn Screens (25' long)
	1018038-120	f/62' w/Corn Screens (25' long)
3	1013541-120	Tube Housing - Middle f/72' only
4-7	---	Tube Housing - Upper
4	1018039-320	f/32' (25'-0" long)
5	1013543-320	f/42' (10'-0" long)
6	1013544-320	f/52' & 72' (20'-0" long)
7	1013545-320	f/62' (30'-0" long)
34	1018014	Upper Drive Housing

HUTCHINSON HOUSINGS FOR INTERMEDIATE BEARINGS

REF. NO.	PART NO.	DESCRIPTION
1	1013335-120	Tube Housing - Lower w/Intake Guard
--	8379C	Bronze Bushing (1 1/4" Bore)
2	---	Tube Housing - Center
	1018036-120	f/42', 52', 62', 72' (25' long)
	1018037-120	f/52' w/Corn Screens (25' long)
	1018038-120	f/62' w/Corn Screens (25' long)
3	1013541-120	Tube Housing - Middle f/72' only
4-7	---	Tube Housing - Upper
4	1018039-220	f/32' (25'-0" long)
5	1013543-220	f/42' (10'-0" long)
6	1013544-220	f/52' & 72' (20'-0" long)
7	1013545-220	f/62' (30'-0" long)
34	1018014	Upper Drive Housing

MISCELLANEOUS COMPONENTS

REF. NO.	PART NO.	DESCRIPTION
8	8309A	Connecting Band - 27" long
9	1007708	Blow-off Cap
10	1007758	Chain for Blow-off Cap
11	1007734	Hitch Pipe
12	1013806	Cover Plate f/Gearbox Housing
13	1013526	Drain Hole Cover
--	1004287	Manual Container



8" INLINE/MID-DRIVE

Page P-6

MAIN AUGER COMPONENTS

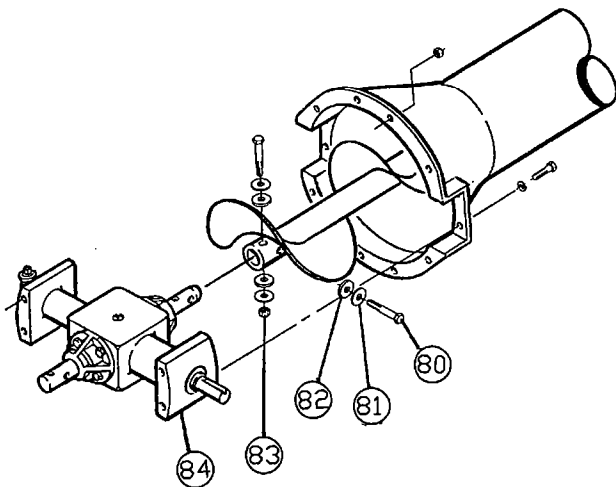
(Parts listed below are shown on pages P-3 & P-4.)

FLIGHT SECTIONS

REF. NO.	PART NO.	DESCRIPTION
15-18	---	Flight - Upper
15	1013403	f/32' (24'-2 3/4" long) 7 ga.
	1013409	f/32' (24'-2 3/4" long) 1/4"
16	1013404	f/42' (8'-8 1/4" long) 7 ga.
	1013410	f/42' (8'-8 1/4" long) 1/4"
17	1013405	f/52' & 72' (18'-8 1/4" long) 7 ga.
	1013411	f/52' & 72' (18'-8 1/4" long) 1/4"
18	1013406	f/62' (28'-8 1/4" long) 7 ga.
	1013412	f/62' (28'-8 1/4" long) (1/4")
19-20	---	Flight - Center
19	1013401	f/42', 52', 62' & 72' (25'-6 1/4" long) 7 ga.
	1013407	f/42', 52', 62' & 72' (25'-6 1/4" long) 1/4"
20	1013402	f/72' (20'-0" long) 7 ga.
	1013408	f/72' (20'-0" long) 1/4"
21	---	Flight - Lower
	1013400	f/All (5'-1" long)

FLIGHT SECTIONS FOR OPTIONAL INTERMEDIATE BEARINGS

REF. NO.	PART NO.	DESCRIPTION
21	1013400	Flight Lower (5'-1" long) All
22	1012239	Flight Upper (4'-9 3/4" long) 7 ga.
	1012241	Flight Upper (4'-9 3/4" long) 1/4"
23	1011315	Flight Intermediate (9'-9 3/4" long) 7 ga.
	1011316	Flight Intermediate (9'-9 3/4" long) 1/4"
24	1013536	Flight Middle (9'-3/4" long) 7 ga.
	1013537	Flight Middle (9'-3/4" long) 1/4"

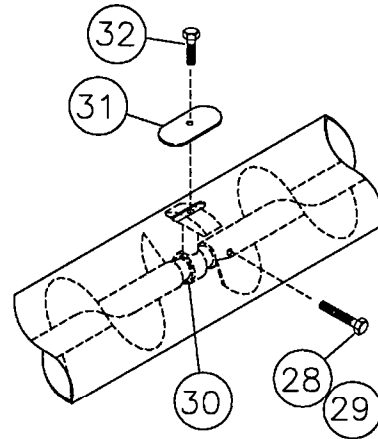


FLIGHT CONNECTING COMPONENTS

REF. NO.	PART NO.	DESCRIPTION
26	1011164	Connecting Stub, Weld-in
27	1013347	Weld-in Intake Stub
28	1009499	Connecting Bolt 7/16" x 3" long (Grade 8)
29	1011181	7/16" Stover Type Locknut
--	8384D	Intake Repair Flight 7" O.D. x 1/4" Thick x 2' long (single flight)

OPTIONAL INTERMEDIATE BEARING COMPONENTS

REF. NO.	PART NO.	DESCRIPTION
30	60522	Internal Bearing Hanger w/Bronze Bushing
--	8379C	Replacement Bronze Bushing Only
31	1012295	Mounting Plate
--	1012297	Bearing Positioning Bar
32	--	5/8" x 1 1/2" Grade 5 Hex Head Capscrew
33	1011166	Connecting Stub, Weld-in
--	1012376	Weld-in Head Stub



GEARBOX FLIGHT CONNECTION COMPONENTS

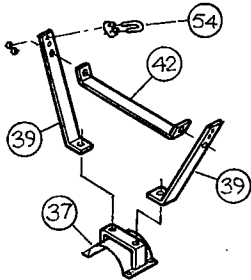
REF. NO.	PART NO.	DESCRIPTION
80	1010269	7/16" x 3 1/2" long (Grade 8)
81	4533	7/16" Plate Washer
82	1022475	1/2" Rubber Washer
83	1011181	7/16" Stove Typ. Locknut
84	1013119-1	8" In-Line Gearbox

MAIN AUGER COMPONENTS

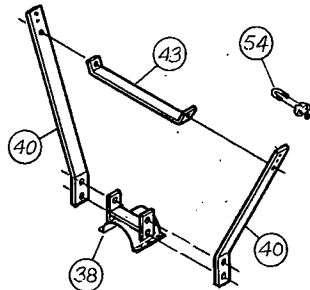
(Some parts listed below are shown on pages P-3 & P-4.)

TRACK & TRUSS COMPONENTS

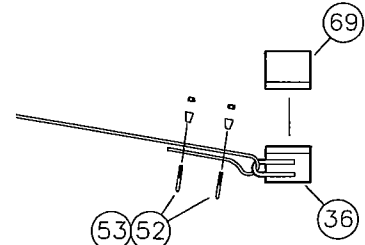
REF. NO.	PART NO.	DESCRIPTION	REF. NO.	PART NO.	DESCRIPTION
36	1007736	Upper Band-on Truss Anchor	60-64	---	Track f/Manual Lift Models
37-38	---	Truss Mount	60	1010077	f/32' (7'-4" long)
37	842159	f/42' Main Truss	61	1010078	f/42' (10'-7" long)
38	1007806	f/52' Main & 72' Upper Truss	62	1013555	f/52' (13'-0" long)
39-41	---	Truss Side Straps	63	1013556	f/62' (15'-6" long)
39	106380	f/42' Main Truss (19" long)	64	1013558	f/72' (20'-1 1/2" long)
40	106399	f/52' Main & 72' Upper Truss (32" long)	65-67	---	Track f/Hydraulic Lift Models
41	1007847	f/62' & 72' Main Truss (39 1/2" long)	65	1007814	f/52' (4'-4 3/4" long)
42-44	---	Truss Crossbrace	66	1013557	f/62' (10'-7" long)
42	862025	f/42' Main Truss (19 3/4" long)	67	1013559	f/72' (19'-5 1/4" long)
43	106398	f/52', 62' & 72' Main Truss (top) (28" long)	68	5042A1	Halfband, 4" wide galv.
44	1007848	f/62' & 72' Main Truss (bottom) (18 5/8" long)	69	842154	Halfband, 6" wide painted
45-50	---	Truss Cable	70-76	---	Spacer Tube
45	1003819	f/42' (1/4" x 28' long)	70	1010104	34 1/4" long (f/32' Manual Lift)
46	1002055	f/52' (1/4" x 36' long)	71	1010105	88 3/4" long (f/42' Manual Lift)
47	1008540	f/62' (5/16" x 45' long)	72	1010276	103 7/8" long (f/52' Hyd. Lift)
48	862027	f/72' w/Manual Lift (5/16" x 31' long)	73	1007700	107" long (f/52' Manual Lift)
49	1013840	f/72' w/Hydraulic Lift (5/16" x 27'-6" long)	74	1013554	114 3/4" long (f/62' Manual Lift)
50	1008553	f/72' (5/16" x 52' long)	75	1007699	116 3/4" long (f/72' Manual Lift)
51	866015-1	Eyebolt 5/8" Dia.	76	1010277	120 3/4" long (f/62' Hyd. Lift)
52	6369C	Cable Clamp - 1/4"	77	1007761	Rest Plate f/52'
53	3153A91	Cable Clamp - 5/16"	78	1012782	Rest plate f/72'
54	3010L11	Cable Clamp - 3/8"	79	1007709	Radius Rod Clamp
55	4841	U-Bolt - 3/8" (f/72' Main Truss)			
56	1006166	Lower Band-on Truss Anchor			
57	1008507	Truss Vertical Tube 56 5/8" long (f/72' only)			
58	1008508	Undertruss Side Strap 30" long (f/72' only)			
59	1007934	Lower Band-on Truss Anchor (f/72')			



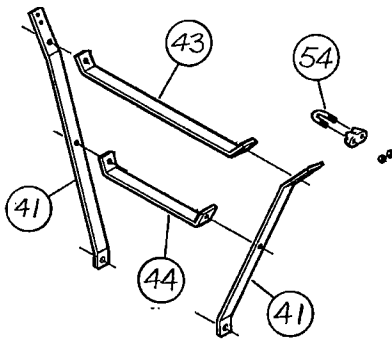
DETAIL A



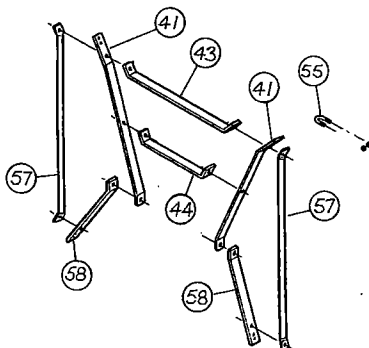
DETAIL B



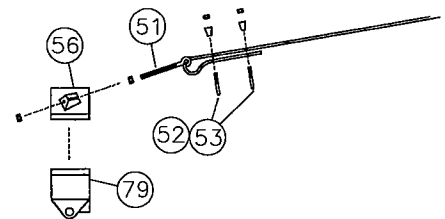
DETAIL E



DETAIL C



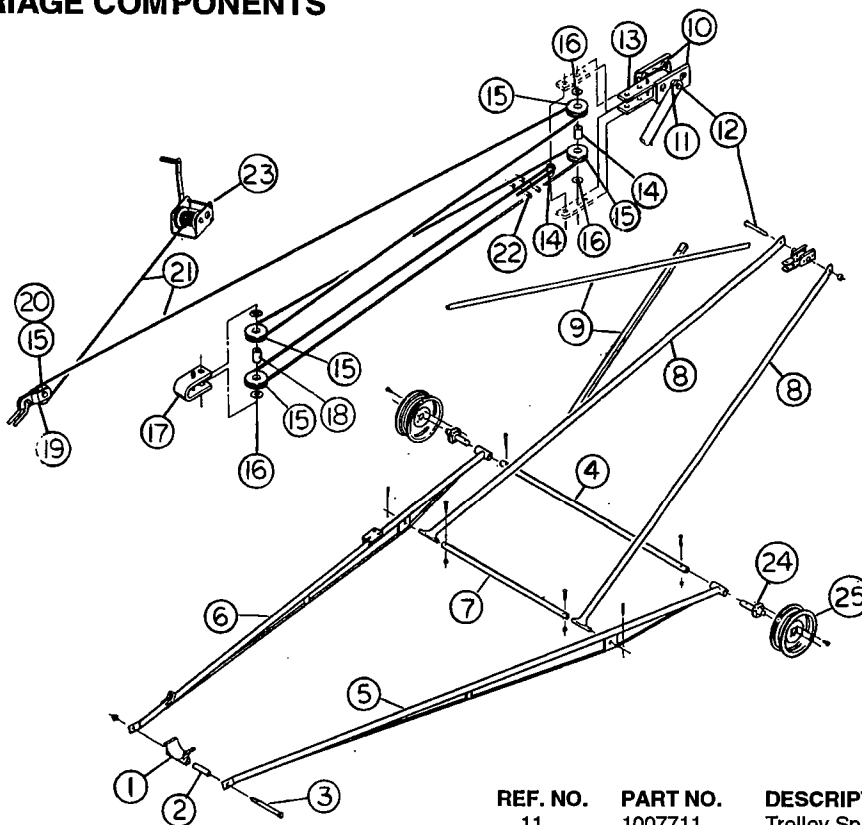
DETAIL D



DETAIL F

8" INLINE/MID-DRIVE

MANUAL LIFT MODEL UNDERCARRIAGE COMPONENTS



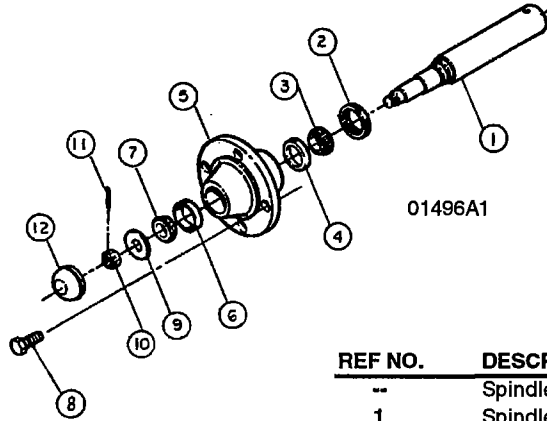
02877A1

REF. NO.	PART NO.	DESCRIPTION	REF. NO.	PART NO.	DESCRIPTION
1	**	Radius Rod Clamp	11	1007711	Trolley Spacer Bushing 4 3/4" long
2	1006164	Radius Rod Spacer Tube (8 1/4" long)	12	33214	Bolt 3/4" x 7" long HHCS (grade 5)
3	835058	Bolt 3/4" x 11" long HHCS	13	1007712	Trolley Pulley Clevis
4	---	Axle	14	1007713	Pulley Clevis Bushing (1 5/8" long)
	1007694	f/32' (73" long)	15	1008195	1/4" Cable Pulley (3.0" O.D.)
	1006100	f/42', 52' (94 1/2" long)	16	1007757	10 Ga. Washer (2 1/8" O.D. x 1 1/8" I.D.)
	1014653	f/62' (93" long)	17	---	Track Pulley Clevis
	1007329	f/72' (120" long)		1008196	f/32' & 42'
5	---	Right Radius Rod		1007754	f/52', 62' & 72'
	1008518	f/32' (6'-5" long)	18	---	Track Pulley Clevis Bushing
	1007626	f/42' (9'-8" long)		1008197	f/32' & 42' (5/8" long)
	1007446	f/52' (12'-2" long)		1007713	f/52', 62' & 72' (1 5/8" long)
	1014699	f/62' (14'-8 3/4" long)	19	1007890	Pulley Straps for Radius Rod
	1007330	f/72' (17'-5 1/4" long)	20	1008197	Cable Pulley Bushing (5/8" long)
6	---	Left Radius Rod w/Winch Mount	21	---	Lift Cable
	1008517	f/32' (6'-5" long)		1002568	f/32' (1/4" x 26' long)
	1007627	f/42' (9'-8" long)		1002573	f/42' (1/4" x 44' long)
	1007447	f/52' (12'-2" long)		1002576	f/52' (1/4" x 75' long)
	1014700	f/62' (14'-8 3/4" long)		1013805	f/62' (1/4" x 91' long)
	1007331	f/72' (17'-5 1/4" long)		1007891	f/72' (1/4" x 118' long)
7	---	Axle Leg Tube	22	6369C	Cable Clamp - 1/4"
	1008516	f/32' (33" long)	23	3339A11	K-1051 Winch (32' Model) (See Page P-9 for parts breakdown.)
	1007703	f/42' (53" long)	23	3335A11	K-1550 Winch (42', 52' & 62' Models) (See Page P-10 for parts breakdown.)
	1007704	f/52' (51" long)	23	40301	K-2550 Winch (72' Model) (See Page P-10 for parts breakdown.)
	1007469	f/62' (49 3/4" long)	24	1001562	Spindle and Hub Assembly 4-bolt (1.62 O.D. Spindle) f/32' Models (See Page P-9 for parts breakdown.)
	1007840	f/72' (72 1/2" long)	24	1001563	Spindle and Hub Assembly 4-bolt (2.062 O.D. Spindle) f/42', 52', 62' & 72' Models (See Page P-9 for parts breakdown.)
8	---	Axle Leg	25	6393D	Wheel Rim (4-Bolt)
	1007578	f/32' (7'-1" long)			
	1007707	f/42' (10'-6 1/2" long)			
	1007449	f/52' (12'-8" long)			
	1007860	f/62' (14'-0" long)			
	1007861	f/72' (16'-1" long)			
9	1007841	Cross Brace Angles			
10	1007753	Trolley (with Steel Rollers)			

** Listed on page P-7.

8" INLINE/MID DRIVE

SPINDLE & HUB ASSEMBLIES



REF NO.	DESCRIPTION	4-BOLT	4-BOLT
		(1 5/8" x 10") f/8" x 32'	(2 1/16" x 10") f/8" x 42', 52', 62' & 72'
--	Spindle & Hub Assy.	1001562	1001563
1	Spindle	1001001	1001002
2	Grease Seal	106245	106245
3	Inner Cone (Timken No.)	3079R1 (LM67048)	3079R1 (LM67048)
4	Inner Cup (Timken No.)	3148R1 (LM67010)	3148R1 (LM67010)
5	Hub **	90174	90174
6	Outer Cup (Timken No.)	40552 (LM11910)	40552 (LM11910)
7	Outer Cone (Timken No.)	40551 (LM11949)	40551 (LM11949)
8	Lug Bolt	106241	106241
9	Washer	106252	106252
10	Slotted Hex Nut (5/8")	106250	106250
11	Cotter Pin (5/32" x 1 1/4")	D1146	D1146
12	Hub Cap	106244	106244

** Furnished with Cups.

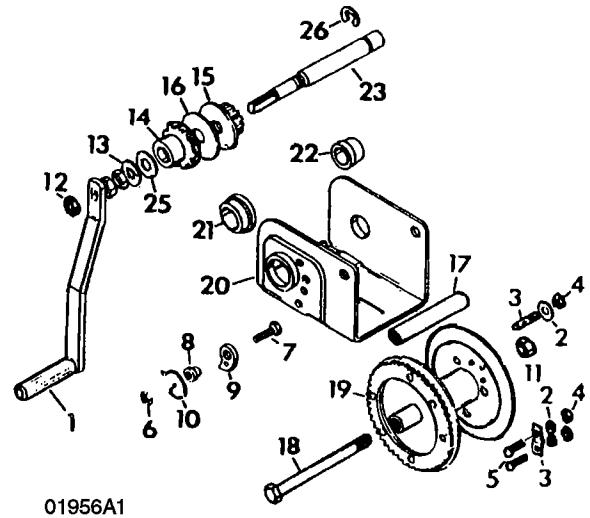
NOTE: Repair parts for winch can also be purchased directly from:

Fulton Manufacturing Corp.
P.O. Box 19903
Milwaukee, WI 53219
715-693-1700

WINCH - BRAKE TYPE

PARTS LIST FOR FULTON MODEL K-1051 WINCH
USED ON 8" x 32' AUGERS
COMPLETE WINCH - PART NUMBER 3339A11

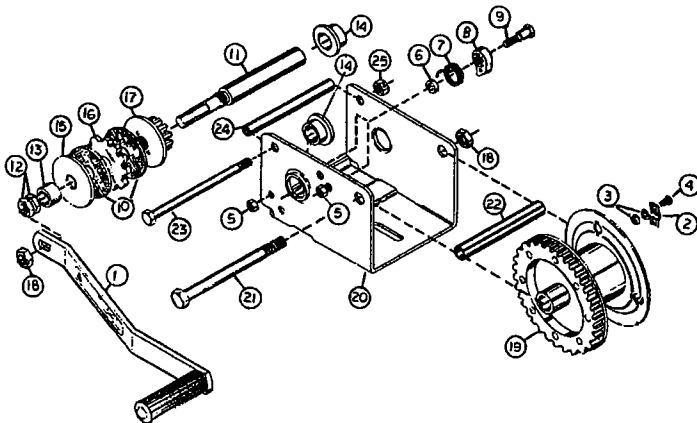
ITEM NUMBER	DESCRIPTION	QTY. REQ.	HUTCHINSON/	
			MAYRATH PART NUMBER	FULTON PART NUMBER
1	11" Handle Assy.	1	41595	2461-01
2-5	Rope Keeper Kit	1	41600	5621S01
6-10	Ratchet Kit	1	40840	6731S00
*11	Locknut - Hex, 3/8-16	1	33234	907-01
*12	Locknut - Hex, 1/2-13	3	33138	952-01
13	Brake Disc	1	41906	2552-01
14	Ratchet Assembly	1	41908	2555-01
15	Pinion Gear Assembly	1	1003595	0434003-01
16	Friction Disc	1	41909	2356-00
17	Spacer Drum	1	41910	6284-05
18	Capscrew Hex - 3/8-16	1	41911	6299-01
19	Drum Assembly	1	41912	9186-01
20	K-1051 Frame Assembly	1	N/A	N/A
21	Bushing 1.25 ID x .50	1	41914	4592-19
22	Bushing .75 ID x .50	1	41915	5790-19
23	Pinion Shaft	1	1003589	0469001-01
25	Washer-Thrust	1	1003590	178-00
26	Retaining Ring	1	1003591	57-01



*Indicates Standard Hardware Items

8" INLINE/MID-DRIVE

WINCH - BRAKE TYPE



01514A1

NOTE: Repair parts for winch can also be purchased directly from:
Fulton Manufacturing Corp.
P.O. Box 19903
Milwaukee, WI 53219
715-693-1700

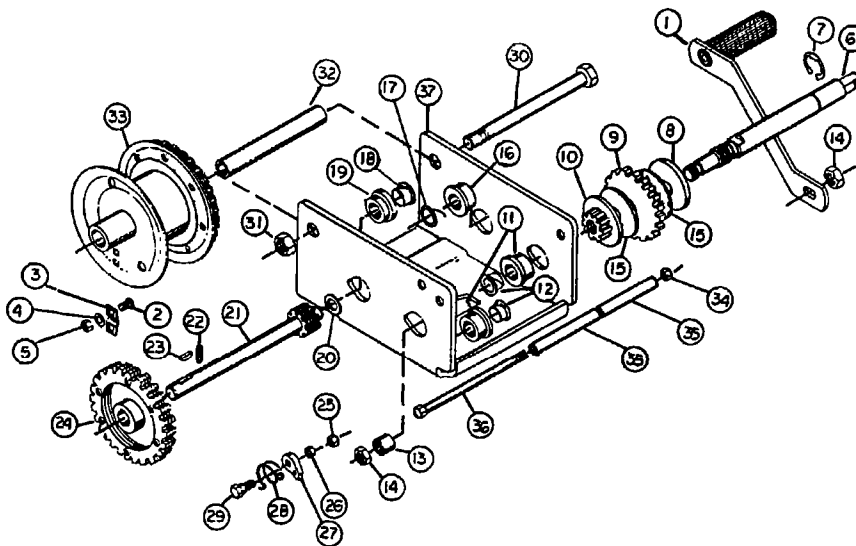
FULTON MODEL K1550 WINCH USED ON 8" x 42', 52' & 62' COMPLETE PART NO. 3335A11

REF NO.	DESCRIPTION	HUTCHINSON/ MAYRATH PART NO.	FULTON PART NO.
1	Handle Assembly	41595	2461S01
2	Cable Clamp		
3	Lock Washer & Nut	Cable Keeper	Cable Keeper
4	Carriage Bolt	Kit 41600	Kit 5621S01
5	Lock Nut 5/16" - 18 Hex		
6	Ratchet Spacer	Ratchet Kit	Ratchet Kit
7	Ratchet Spring	40836	6730S00
8	Ratchet Pawl		
9	Hex Head Shoulder Bolt 5/16" - 18		
10	Brake Disc Kit	41596	1558S00
11	Input Shaft		
12	Lock Nut 1/2" - 13 Hex		
13	Spacer	Input Shaft	Input Shaft
14	Bushing	Kit	Kit
15	Shaft Brake Disc	41597	1563S01
16	Ratchet Gear		
17	Pinion & Disc Assembly		
18	Hex Lock Nut 1/2" - 13	*	*
19	Drum Assembly	**	**
20	Frame	**	**
21	Hex Head Capscrew 1/2" - 13 - 5 3/4"	*	*
22	Drum Spacer	**	**
23	Hex Head Capscrew 3/8" - 16 - 5 3/4"	*	*
24	Frame Spacer	**	**
25	Hex Lock Nut 3/8" - 18	*	*
26	Handle Label	2169A1	**

*Indicates standard hardware items - purchase locally.

**These items are not available as separate parts because of the precision assembly required. If these parts require replacement, a new winch unit is recommended.

WINCH - BRAKE TYPE



01513A1

NOTE: Repair parts for winch can also be purchased directly from:
Fulton Manufacturing Corp.
P.O. Box 19903
Milwaukee, WI 53219
715-693-1700

PARTS LIST FOR FULTON MODEL K2550 WINCH USED ON 8" x 72' COMPLETE PART NO. 40301

REF NO.	DESCRIPTION	HUTCHINSON/ MAYRATH PART NO.	FULTON PART NO.
1	Handle	41595	2461S01
2	Bolt	Cable Keeper	Cable Keeper
3	Cable Clamp	Kit	Kit
4	Lockwasher	41600	5621S01
5	Nut		
6	Input Shaft		
7	Retaining Ring		
8	Brake Disc	Input Shaft	Input Shaft
9	Ratchet Gear	Kit	Kit
10	Pinion Gear	41598	1565S01
11	Bushing		
12	Insert		
13	Spacer		
14	Nut		
15	Friction Disc	41601	Kit 1578S00
16	Bushing		
17	Insert		
18	Insert		
19	Bushing	Intermediate	Intermediate
20	Washer	Shaft	Shaft
21	Intermediate Shaft	Kit	Kit
22	Roll Pin	41599	1569S01
23	Woodruff Key		
24	Gear		
25	Nut		
26	Spacer	Ratchet Kit	Ratchet Kit
27	Ratchet Pawl	40836	6730S00
28	Spring		
29	Shoulder Bolt		
30	Drum Bolt T-Grade 5	*	*
31	Locknut	*	*
32	Drum Spacer	**	**
33	Drum Assembly	**	**
34	Locknut	*	*
35	Frame Spacer	**	**
36	Bolt	*	*
37	Frame	**	**

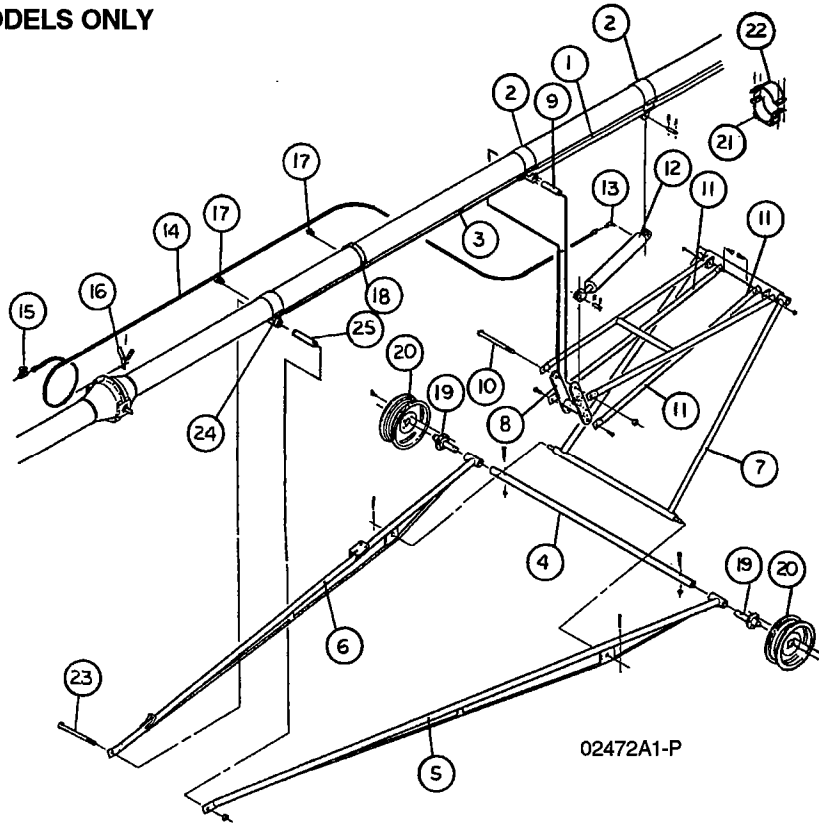
*Indicates standard hardware items - purchase locally.

**These items are not available as separate parts because of the precision assembly required.

8" INLINE/MID-DRIVE

HYDRAULIC LIFT MODEL UNDERCARRIAGE COMPONENTS

52', 62' & 72' MODELS ONLY



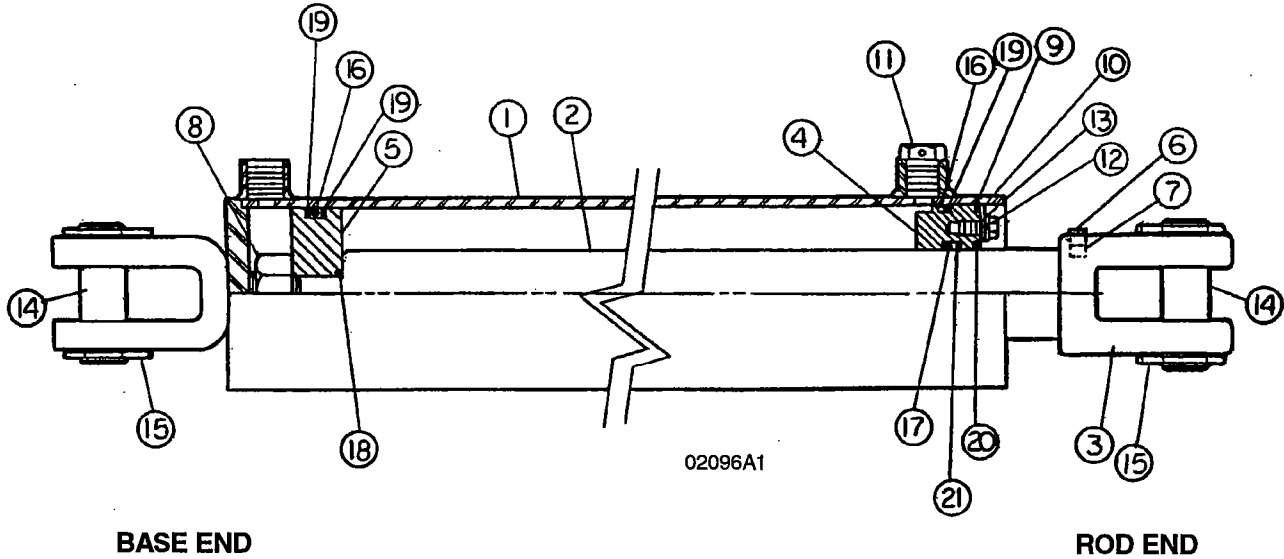
REF NO.	PART. NO.	DESCRIPTION	REF NO.	PART. NO.	DESCRIPTION
1	**	Track	11	---	"H" Frame to Undercarriage Frame Tube
2	**	Halfband		1007796	f/52' (64" long)
3	**	Spacer Tube		1007864	f/62' (82" long)
	1010276	f/52' (103 7/8" long)		1007865	f/72' (96 1/2" long)
	1010277	f/62' (120 3/4" long)	12	---	Hydraulic Cylinder
4	---	Axle			(See Page P-12 for parts breakdown)
	1006100	f/52' (94 1/2" long)		1004368	f/52' & 62' (4" Bore x 24" Stroke)
	1014653	f/62' (93" long)		1004369	f/72' (4" Bore x 36" Stroke)
	1007329	f/72' (120" long)	13	106413	90° Street El (1/2" Pipe)
5	---	Right Radius Rod	14	---	3/8" Dia. Hydraulic Hose
	1007446	f/52' (12'-2" long)		1007944	f/52' (29'-0" long)
	1014699	f/62' (14'-8 3/4" long)		1013268	f/62' (34'-6" long)
	1007330	f/72' (17'-5 1/4" long)		1013269	f/72' (39'-0" long)
6	---	Left Radius Rod	15	1005886	Ball Valve (1/2" Pipe)
	1007447	f/52' (12'-2" long)	16	1007735	Hose Carrier Bracket
	1014700	f/62' (14'-8 3/4" long)	17	1006324	Hose Clamp
	1007331	f/72' (17'-5 1/4" long)	18	5033A1	Halfband 2" wide (for Hose Clamps)
7	---	Undercarriage Frame	19	1001563	Spindle and Hub Assembly 4-Bolt (See Page P-9 for parts breakdown.)
	1007686	f/52'	20	6393D	Wheel Rim (4-Bolt)
	1007687	f/62'	21	**	Rest Plate f/52' only
	1007688	f/72'	22	**	Half Band for Rest Plate
8	---	"H" Frame Weldment	23	835058	Bolt 3/4" x 11" long HHCS
	1007689	f/52' & 62'	24	**	Radius Rod Clamp
	1007690	f/72'	25	1006164	Radius Rod Spacer Tube (8 1/4" long)
9	---	Spacer Tube f/H-Frame			
	1007939	f/52' & 62' (8 1/4" long)			
	1007940	f/72' (9 1/4" long)			
10	---	H-Frame Bolt			
	1007941	f/52' & 62' (1" x 11" long)			
	1007942	f/72' (1" x 12" long)			
-	1007943	1" Nylon Locknut			

** This part is listed on page P-7.

8" INLINE/MID-DRIVE

Page P-12

HYDRAULIC CYLINDER MANUFACTURED BY NECO



4" BORE x 24" STROKE
COMPLETE NO. 1004368
USED ON 8" x 52' & 62'

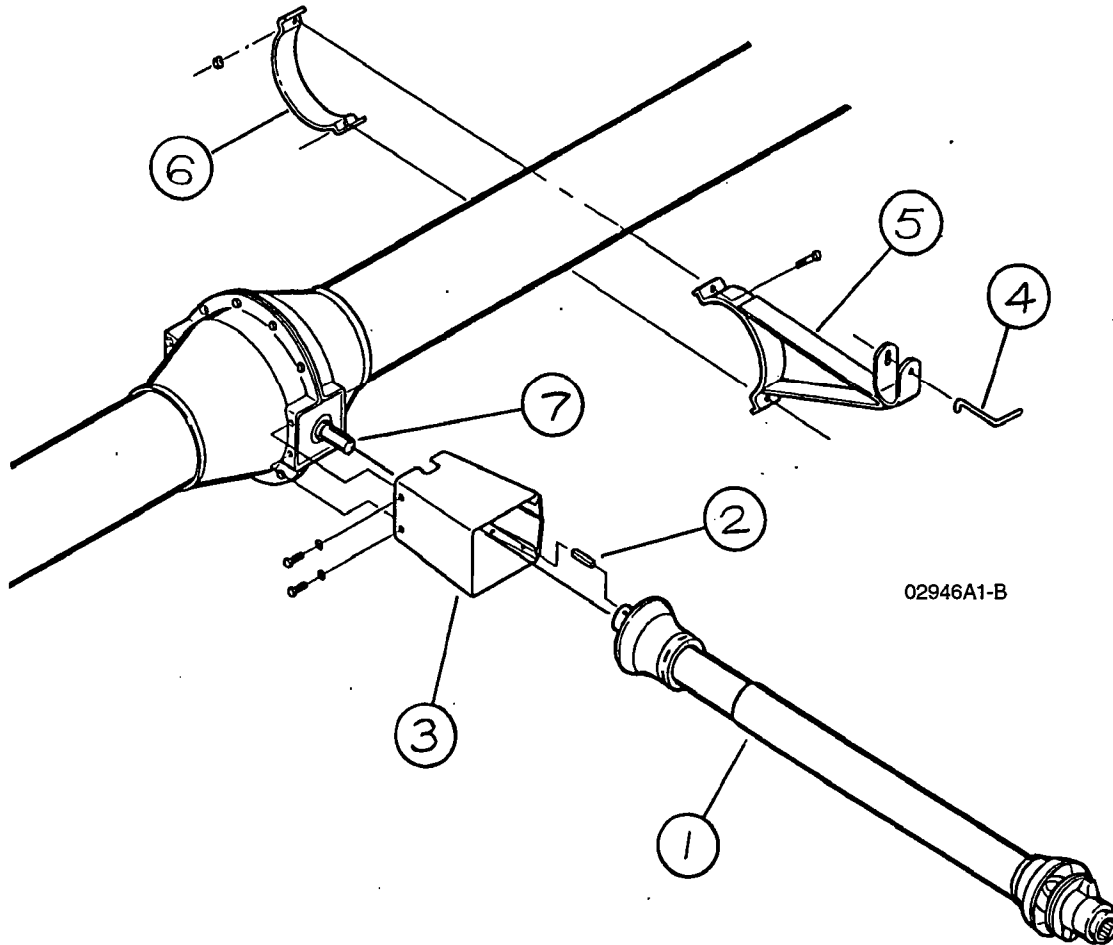
4" BORE x 36" STROKE
COMPLETE NO. 1004369
USED ON 8" x 72'

REF. NO.	DESCRIPTION	PART NO.	PART NO.
1	Cylinder Body	042006	42889
2	Piston Rod	042000	042013
3	Clevis	14980	14980
4	Gland	042002	42899
5	Piston	1004910	1004910
6	Setscrew 5/16" x 3/8" long	----	----
7	Nylon Plug	49049	49049
8	Nut - Lock 1"	042021	042021
9	Snap Ring	1004911	1004911
10	Retaining Plate	042004	042004
11	Breather Plug (1/2" NPT)	042016	042016
12	Bolt 5/16" - 3/4" long	4701-1	4701-1
13	Lock Washer 5/16"	33144	33144
14	Cylinder Pin 1" - 3-5/8"	1005212	1005212
15	Clip - Hairpin 3/16" x 1"	036719	036719
16	*O-Ring Large	Seal Kit 042014	Seal Kit 042015
17	*O-Ring Seal		
18	*O-Ring Small		
19	*Back-Up Washer		
20	*Piston Rod Wiper		
21	*Back-up Washer		

* ONLY AVAILABLE AS PART OF A SEAL KIT.

8" INLINE/MID-DRIVE

PTO DRIVE COMPONENTS

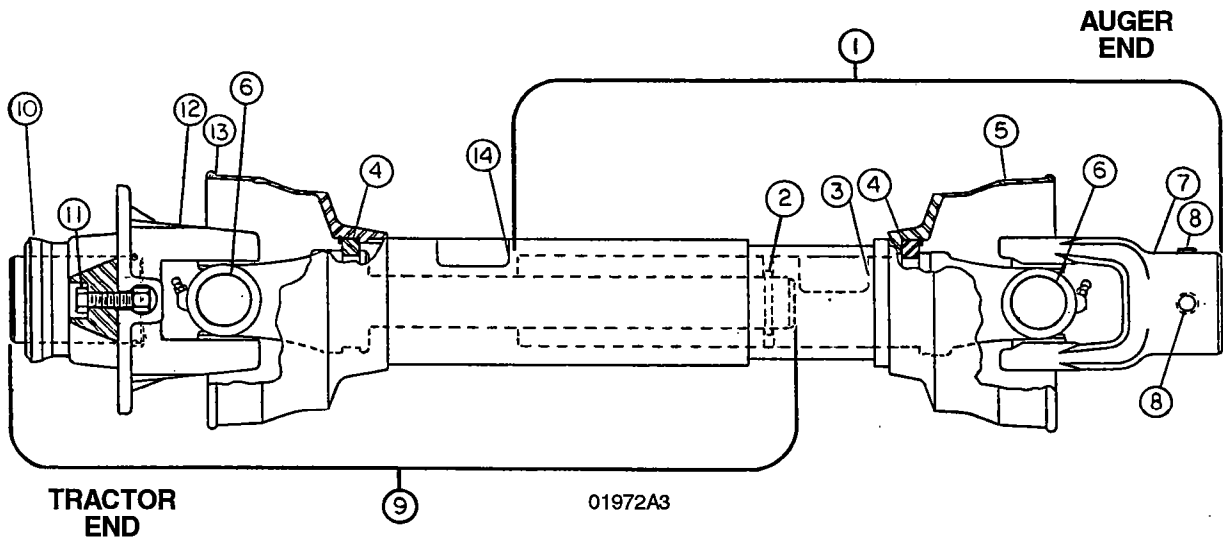


REF. NO.	PART NO.	DESCRIPTION
1	1002171	PTO Driveline (See parts breakdown on Page P-14.)
2	8371C	Key 1/4" x 1 1/2" long
3	1007899	PTO Driveline to Auger Shield
4	3338A1	Transport Keeper Pin
5	1003211	PTO Driveline Transport Bracket
6	5033A1	Halfband 2" wide
7	---	Gearbox (See gearbox information on Page P-15.)

8" INLINE/MID-DRIVE

Page P-14

AUGER PTO DRIVELINE MANUFACTURED BY WEASLER



NOTE: Repair parts for PTO drivelines can also be purchased directly from:

Weasler Engineering, Inc.
P.O. Box 558
West Bend, WI 53095
414-338-2161

SPECIFICATIONS:

U-JOINT TYPE - 12R
AUGER END 1" BORE
WITH 1/4" KEYSEAT
TRACTOR END 1 3/8 - 6B SPLINE
WITH SHEAR BOLT

REF. NO.	DESCRIPTION
--	PTO Driveline Complete
1	Joint & Tube Half Assembly with Guard (Auger End)
2	Roll Pin 1/4" x 1" long
3	Inner Safety Sign
4	Shield Nylon Bearing Kit
5	Inner Guard (Includes Ref. No. 4)
6	U-Joint Cross Repair Kit
7	End Yoke
8	.375 - 16 x .38 long Setscrew
9	Joint & Shaft Half Assembly with Guard (Tractor End)
10	Spring Lock Flange Repair Kit
11	Shear Bolt & Nut Kit (See Note)
12	Yoke & Ball Shear Assembly
13	Outer Guard (Includes Ref. No. 4)
14	Outer Safety Sign

HUTCHINSON/

MAYRATH PART NO.	WEASLER PART NO.
1002171	222-15986
1015283	92-15986
1003691	11-10454
13-10022	13-10022
1006753	19-11110
1006483	96-15986
40515	03-10077
1003664	12021-1082
33170	N/A
1015284	93-15986
1003674	26-10133
1004778	--
1006485	26-11671
1006486	97-15986
13-10021	13-10021

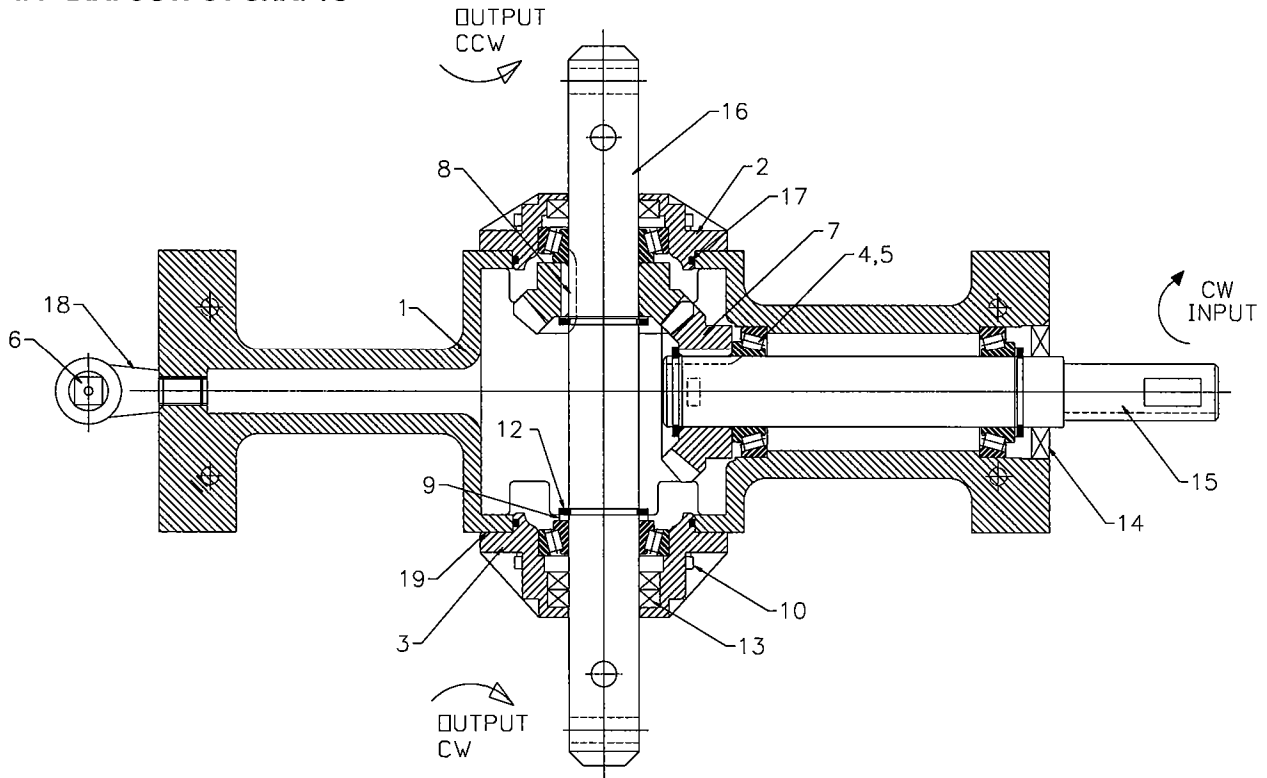
Note: Shear Bolt Kit includes (6) 5/16" - 18 x 1" long Grade 5 hex bolts and locknuts.

8" INLINE/MID-DRIVE

GEARBOX

STANDARD (Ratio 1 to 1) Complete Part No. 1013119-1 (Color: Red)

1" DIA. INPUT SHAFT
1 1/4" DIA. OUTPUT SHAFTS



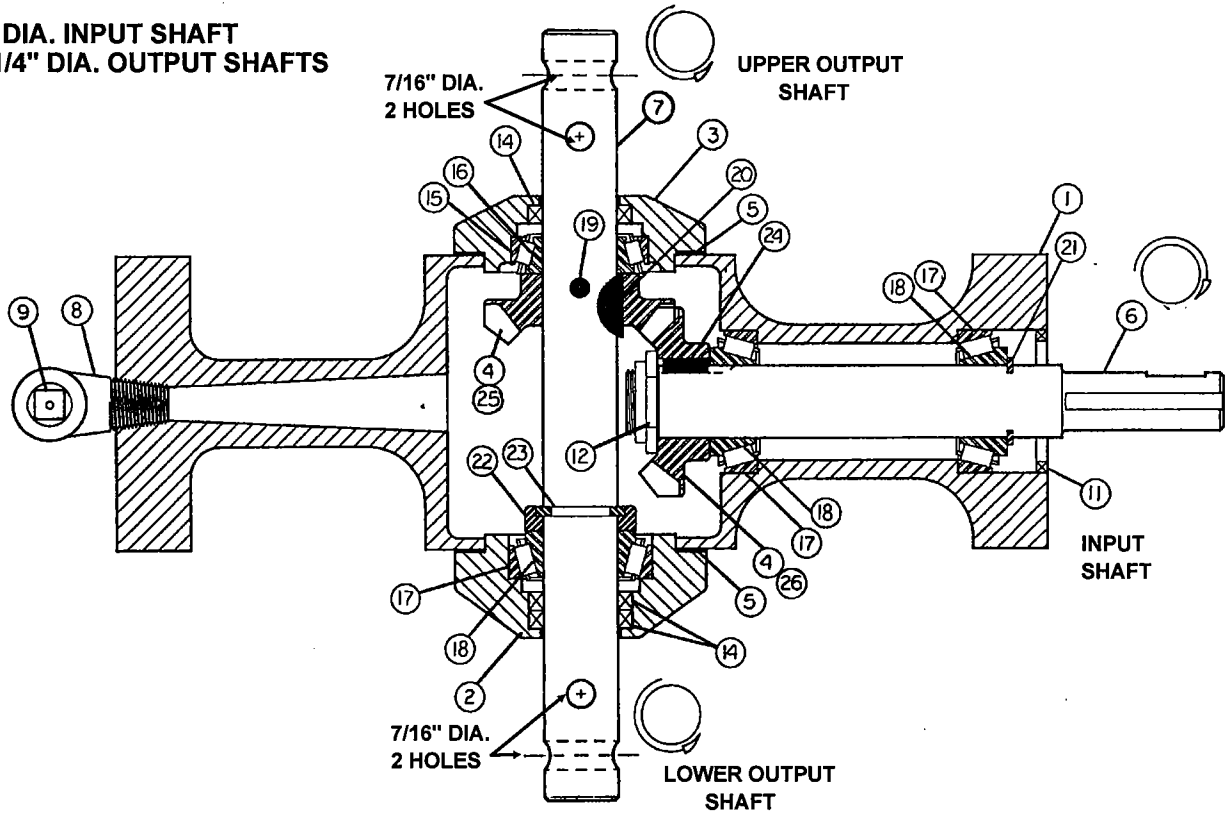
REF. NO.	QTY.	HUTCHINSON/ MAYRATH PART NO.	WEASLER PART NO.	DESCRIPTION
1	1	--	--	Housing (Not available)
2	1	1027832	70-10026	Top Cap
3	1	1027833	70-10027	Bottom Cap
4	4	3079R1	--	1-1/4" Cone (Timken #LM67048)
5	4	3148R1	--	1-1/4" Cup (Timken #LM67010)
6	1	035926	--	1/2" Vent Plug
7	2	1027834	71-00022	Gear 19 Tooth - 1-1/4" Bore
8	2	020108	--	Key, 1/4" Square x 7/8" long
9	1	1027835	71-50016	Spacer
10	8	4701-1	--	Bolt, 5/16" x 3/4" long Hex Head Capscrew
11	2	020009	--	1/4" Pipe Plug
12	4	003538	--	Snap Ring
13	3	1027836	71-40003	Seal, 1-1/4" I.D. x 2" O.D. x 5/16" wide
14	1	1027837	71-40002	Seal, 1-1/4" I.D. x 2-3/8" O.D x 5/16" wide
15	1	1027838	71-10069	Input Shaft
16	1	1027839	71-10070	Output Shaft
17	2	1023282	72-70002	O-Ring (3.15" O.D.)
18	1	420022	--	Elbow
19	A/R	1027840	71-50020	Gasket

8" INLINE/MID-DRIVE

GEARBOX

REDUCTION (Ratio 1.35 to 1) Complete Part No. 1013828 (Color: Black)

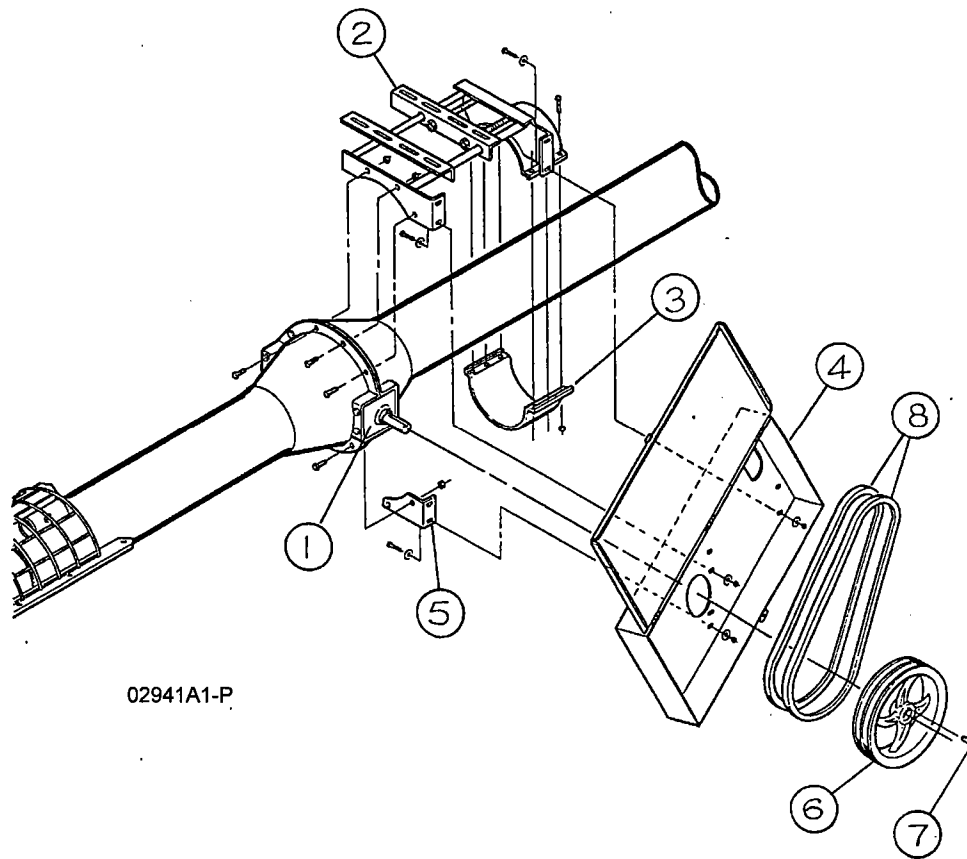
1" DIA. INPUT SHAFT
1 1/4" DIA. OUTPUT SHAFTS



REF. NO.	QTY.	REDUCTION GEARBOX (COLOR: BLACK) PART NO.	DESCRIPTION
1	1	020331	Housing
2	1	020046	Bottom Cap
3	1	020030	Top Cap
4	2	---	Gear 19 Tooth 1 1/4" Bore
5	2	020006	Gasket .003
5	2	020007	Gasket .005
5	2	020008	Gasket .014
6	1	020333	Input Shaft
7	1	1013132	Through Shaft
8	1	420022	Elbow
9	1	035926	1/2" Vent Plug
10	2	* 020009	1/4" Drain Plug
11	1	035245	Seal 1 1/4" x 2 7/16" O.D.
12	1	837028	1 1/8" Stake Nut
13	8	* 003093	5/16" x 7/8" HHCS Gr. 5 w/Nylock
14	3	035233	Seal 1 1/4" x 1 3/4" O.D.
15	1	3148R1	1 1/4" Cup (Timken #LM67010)
16	1	3079R1	1 1/4" Cone (Timken #LM67048)
17	3	106323	1 1/4" Cup (Timken #15245)
18	3	035241	1 1/4" Cone (Timken #15126)
19	1	6386C	Roll Pin (5/16" x 2" long)
20	1	1007288	Key - Woodruff (5/16" x 1")
21	1	003538	Snap Ring (Waldes)
22	1	020028	Retainer for Snap Ring
23	1	003381	Snap Ring
24	1	020108	Key 1/4" x 5/16" x 7/8"
25	1	020022	Gear 19 Tooth 1 1/4" Bore
26	1	020026	Gear 14 Tooth 1 1/4" Bore

* Parts not shown.

ELECTRIC DRIVE COMPONENTS



02941A1-P

REF. NO.	PART NO.	DESCRIPTION
1	---	Gearbox (See Page P-15 for parts breakdown)
	1013119	Standard
	1013828	Reduction
2	1013546	Motor Mount Frame
3	842154	8" Half Band (6" wide)
4	1013547	Belt Guard Weldment
5	1013548	Mounting Bracket f/Belt Guard
6	40157	15" Sheave 2B 1" Bore f/32', 42' & 52' Models
6	40160	15" Sheave 3B 1" Bore f/62' & 72' Models
7	4045A1	Square Key 1/4" x 2" long
8	40124	B-66 Belt



Hutchinson/Mayrath

A Division of **GLOBAL** Industries, Inc.

P.O. Box 629 514 W. Crawford Clay Center, KS 67432
Phone 785-632-2161 1-800-523-6993 FAX 785-632-5964