

TRAC-MASSTER FLAT STORAGE UNLOADER

OWNER'S & OPERATOR'S MANUAL

Effective August 13, 2001

Publication No. 34552

AGI  HUTCHINSON MAYRATH

Hutchinson | Mayrath • P.O. Box 629 • Clay Center, KS. USA 67432

P 785.632.2161 • F 785.632.5964 • TF 800.523.6993

hutchinson-mayrath.com

aggrowth.com | **AGI **

HUTCHINSON | MAYRATH

POLICIES and PROCEDURES

Prices: Prices in effect at time of shipment will apply. Prices are subject to change without notice. All prices are F.O.B. Clay Center, Kansas. Orders shipped from locations other than Clay Center, Kansas will be subject to additional charges, such as back freight and/or additional freight.

Service Charge: A service charge will be assessed for all past due balances as permitted by state law not to exceed 1-1/2% per month.

Minimum Order: Processing and handling costs necessitate a minimum charge of \$15.00 net on all orders.

Back Orders: Back orders will be shipped as they become available. Contact Hutchinson,Mayrath Customer Service for alternative shipping options or if cancellation is desired.

Damaged Goods: It is the consignee's responsibility to check all shipments thoroughly upon receipt of goods. If any damage is discovered, it must be noted on the freight bill of lading before signing. The consignee must make necessary claims against the respective freight line. All damage claims must be submitted within 30 days of delivery receipt.

Shortages: All shortages must be noted at time of delivery. Shortages must be noted on the freight bill of lading before signing. Hutchinson,Mayrath must be advised of all concealed shortages upon discovery. Once notified of concealed shortages Hutchinson,Mayrath will advise corrective action to be taken.

Return of Goods: All returns must be approved by Hutchinson,Mayrath prior to shipment. All return requests will be issued a return authorization number. **NO RETURNS WILL BE ACCEPTED WITHOUT A RETURN AUTHORIZATION NUMBER AND PRIOR AUTHORIZATION FROM THE FACTORY.** All returns must be shipped prepaid. A 15% restocking charge will be applied to all returned merchandise. Custom Products may not be returned for credit. Only current products in new and salable condition may be returned. No safety devices may be returned for credit.

Modifications: It is the policy of Hutchinson,Mayrath to improve its product whenever possible and practical to do so. We reserve the right to make changes, improvements and modifications at any time without incurring the obligation to make such changes, improvements and modifications on any equipment sold previously.

Limited Warranty: (a) For a period of (1) year after receipt of goods by the original consumer buyer, Hutchinson,Mayrath will supply free of charge replacement parts for parts that prove defective in workmanship or material. Defective parts must be returned freight prepaid to a specified Hutchinson,Mayrath location. Only Hutchinson,Mayrath original repair parts may be used for warranty repairs.

(b) This limited warranty does not extend to parts designed to wear in normal operation and be replaced periodically; or to damage caused by negligence, accident, abuse or improper installation or operation.

(c) **GOODS NOT MANUFACTURED BY HUTCHINSON,MAYRATH CARRY ONLY THE MANUFACTURER'S WARRANTY.**

(d) **THIS UNDERTAKING IS IN LIEU OF ALL OTHER WARRANTIES, EXPRESSED OR IMPLIED, INCLUDING MERCHANTABILITY AND FITNESS FOR A PARTICULAR PURPOSE.**

FAILURE TO FOLLOW THE INSTRUCTIONS CONTAINED IN THE OWNER'S & OPERATOR'S MANUALS AND THE ITEMS LISTED BELOW WILL RESULT IN THE VOIDING OF THIS LIMITED WARRANTY.

(1) Improper assembly, including failure to properly install all safety equipment.

(2) Improper installation.

(3) Unauthorized alternations of goods.

(4) Goods operated when obviously in need of repair.

(5) Use of unauthorized repair parts.

(6) Irresponsible operation.

(7) Used to handle materials other than free flowing, nonabrasive and dry materials, as intended.

(8) Damaged through abusive use or accident.

Limitation of Liability: BUYER AGREES THAT IN NO EVENT SHALL HUTCHINSON,MAYRATH HAVE LIABILITY FOR DIRECT DAMAGES IN EXCESS OF THE CONTRACT PRICE OF THE GOODS IN RESPECT OF WHICH CLAIM IS MADE. BUYER FURTHER AGREES THAT IN NO EVENT SHALL HUTCHINSON,MAYRATH ON ANY CLAIM OF ANY KIND HAVE LIABILITY FOR LOSS OF USE, LOSS OF PROFITS, OR FOR ANY INDIRECT, INCIDENTAL OR CONSEQUENTIAL DAMAGES.

GENERAL SAFETY STATEMENT

This manual was written with the safety of the operator and others who work with the equipment as our prime concern. The instructions presented will help the reader learn SAFE day to day work practices. We want you as our partner in safety.

It is your responsibility as an owner, operator or supervisor to know what specific safety requirements and precautions exist and to make these known to all other personnel working with the equipment or in the area, so that they too may safely perform their duties and avoid any potentially hazardous situations.

Please remember safety equipment provides important protection for persons around a grain handling system that is in operation. Be sure that ALL safety shields and protection devices are installed and properly maintained. If any shields or guards are damaged or missing, contact your dealer to obtain the correct items.

Avoid any alterations of the equipment. Such alterations may create a dangerous situation where serious injury or death may occur.

SAFETY ALERT SYMBOL

The symbol shown below is used to call your attention to instructions concerning your personal safety. Watch this symbol - it points out important safety precautions. It means "ATTENTION! Become alert! Your personal safety is involved!" Read the message that follows and be alert to the possibility of personal injury or death.



BE ALERT! YOUR SAFETY IS INVOLVED.



WARNING

Anyone who will operate or work around this machine shall first read this manual! This manual must be delivered with the equipment to its owner. Failure to read this manual and its safety instructions is a misuse of the equipment.

TABLE OF CONTENTS

General Safety Statement	1
Safety Symbol	1
Warranty	3
Operator's Qualifications	4
Sign Off Sheet	4
Machine Inspection	5
Hitching to Tractor Instructions	5-9
Three Point Hitch Attachment	6
Input Drive Line Attachment	7
Hydraulics Information	8
Front Tractor Attachment	9
Transporting	10
Designated Work Area	11
Operating	12-15
Planning and Preparation	12
Start-up	12
Feeding	13
Optional Discharge Spouts	14
Optional Intake Hopper	14
Capacities	15
Shutdown	15
Lockout	15
Clean-up and Storage.....	15
Lubrication and Maintenance	16-19
Conveyor Chain	16
Ball Bearings	16
Input Drive Line	17
Clutch Adjustment	17
Undercarriage Axle Spindle Bearing	18
Caster Wheel Post	18
Hydraulic Hose and Fittings	18
Drive Chain Tension	19
Chain Guard	19
Trouble Shooting	20
Safety and Maintenance Decals	21
Dimensions	22
Assembly Instructions	23- 30
Trunking Assembly	23
Conveyor Chain and Paddles	24
Spindle and Hubs	24
Undercarriage Assembly	25-26
Front Tractor Attachment	27
Input Drive Line to Gearbox	28
Category #3 Three-Point Hitch Kit	28
Optional Intake Hopper	29
Optional Adjustable Swivel Spout	30

RIGHT and LEFT DESIGNATION

When determining which is the left or right hand side of the unit, it is as if a person were standing at the intake end and looking toward the discharge end.



Hutchinson/Mayrath

A Division of **GLOBAL Industries, Inc.**

POLICIES AND PROCEDURES

- PRICES:** Prices in effect at time of shipment will apply. Prices are subject to change without notice. All prices are F.O.B. Clay Center, Kansas. Orders shipped from locations other than Clay Center, Kansas will be subject to additional charges, such as back freight and/or additional freight.
- SERVICE CHARGE:** A service charge will be assessed on all past due balances as permitted by state law not to exceed 1-1/2% per month.
- MINIMUM ORDER:** Processing and handling costs necessitate a minimum charge of \$15.00 net on all orders.
- BACK ORDERS:** Back orders will be shipped as they become available. Contact Hutchinson/Mayrath Customer Service for alternative shipping options or if cancellation is desired.
- DAMAGED GOODS:** It is the consignee's responsibility to check all shipments thoroughly upon receipt of goods. If any damage is discovered, it must be noted on the freight bill of lading before signing. The consignee must make necessary claims against the respective freight line. All damage claims must be submitted within 30 days of delivery receipt.
- SHORTAGES:** All shortages must be noted at time of delivery receipt. Shortages must be noted on the freight bill of lading before signing. Hutchinson/Mayrath must be advised of all concealed shortages upon discovery. Once notified of concealed shortages Hutchinson/Mayrath will advise corrective action to be taken.
- RETURN OF GOODS:** All returns must be approved by Hutchinson/Mayrath prior to shipment. All return requests will be issued a return authorization number. **NO RETURNS WILL BE ACCEPTED WITHOUT A RETURN AUTHORIZATION NUMBER AND PRIOR AUTHORIZATION FROM THE FACTORY.** All returns must be shipped prepaid. A 15% restocking charge will be applied to all returned merchandise. Custom Products may not be returned for credit. Only current products in new and salable condition may be returned. No safety devices may be returned for credit.
- MODIFICATIONS:** It is the policy of Hutchinson/Mayrath to improve its product whenever possible and practical to do so. We reserve the right to make changes, improvements and modifications at any time without incurring the obligation to make such changes, improvements and modifications on any equipment sold previously.
- LIMITED WARRANTY:**
- (a) For a period of (1) year after receipt of goods by the original consumer buyer, Hutchinson/Mayrath will supply free of charge replacement parts for parts that prove defective in workmanship or material. Defective parts must be returned freight prepaid to a specified Hutchinson/Mayrath location. Only Hutchinson/Mayrath original repair parts may be used for warranty repairs.
 - (b) This limited warranty does not extend to parts designed to wear in normal operation and be replaced periodically; or to damage caused by negligence, accident, abuse or improper installation or operation.
 - (c) **GOODS NOT MANUFACTURED BY HUTCHINSON/MAYRATH CARRY ONLY THE MANUFACTURER'S WARRANTY.**
 - (d) **THIS UNDERTAKING IS IN LIEU OF ALL OTHER WARRANTIES, EXPRESSED OR IMPLIED, INCLUDING MERCHANTABILITY AND FITNESS FOR A PARTICULAR PURPOSE.**
- FAILURE TO FOLLOW THE INSTRUCTIONS CONTAINED IN THE OWNER'S & OPERATOR'S MANUALS AND THE ITEMS LISTED BELOW WILL RESULT IN THE VOIDING OF THIS LIMITED WARRANTY.**
- 1) Improper assembly, including failure to properly install all safety equipment.
 - 2) Improper installation (power & wiring included).
 - 3) Unauthorized alterations of goods.
 - 4) Goods operated when obviously in need of repair.
 - 5) Use of unauthorized repair parts.
 - 6) Irresponsible operation.
 - 7) Used to handle materials other than free flowing, non-abrasive and dry materials, as intended.
 - 8) Damaged through abusive use or accident.
- LIMITATION OF LIABILITY:** BUYER AGREES THAT IN NO EVENT SHALL HUTCHINSON/MAYRATH HAVE LIABILITY FOR DIRECT DAMAGES IN EXCESS OF THE CONTRACT PRICE OF THE GOODS IN RESPECT OF WHICH CLAIM IS MADE. BUYER FURTHER AGREES THAT IN NO EVENT SHALL HUTCHINSON/MAYRATH ON ANY CLAIM OF ANY KIND HAVE LIABILITY FOR LOSS OF USE, LOSS OF PROFITS, OR FOR ANY INDIRECT, INCIDENTAL OR CONSEQUENTIAL DAMAGES.

MACHINE INSPECTION

After delivery of your new portable conveyor and/or completion of assembly and before each use, inspection of the machine is mandatory. This inspection should include, but not be limited to:

1. Check to see that all guards listed in the assembly instructions are in place and secured and functional. Input Drive Line Shields must rotate easily.
2. Check all safety signs and replace any that are worn, missing or illegible. The safety signs are listed on page 22 of this manual. Safety signs may be obtained from your Hutchinson Dealer or ordered from the factory.
3. Are all fasteners tight?
4. Inspect hopper and intake auger area for bent and damaged parts. Replace or repair any parts that are bent or broken.
5. Check all the hydraulic hoses, fittings and tubing to see if they are tight and not leaking hydraulic oil.
6. Check the front tractor conveyor mount to see that it is securely fastened.
7. Check that keeper pins are securely holding conveyor to tractor three point hitch.

HITCHING TO TRACTOR

The portable conveyor was designed to use a tractor with the following specifications:

1. Tractor Size
90 HP or larger (for proper and efficient handling during grain moving operation and during transport). Actual PTO HP required for powering conveyor is 60 HP.
Maximum tractor width- 8'-6"
2. Tractor Equipment
 - A. 540 RPM Power Take Off
 - B. Three point hitch
 - C. Hydraulic control circuit for undercarriage lift with an 1800 to 2000 PSI capacity.

NOTE: If the conveyor is equipped with an optional hydraulic control discharge spout, a separate hydraulic circuit will be needed.



Never stand between tractor and conveyor when hitching unless all controls are in neutral and the brakes locked.

Follow these steps when hitching conveyor to tractor:

1. Back the tractor into hitching position and align with conveyor.
2. Fasten lower three point hitch arms to conveyor. There is no attachment for the top link of the three point hitch. See page 6.
3. Attach the Input Drive Line to the tractor. See page 7 for attachment details.
4. Connect hydraulic hose to tractor. See page 8 for hydraulic information.
5. Fasten front mount to tractor. See page 9 for attachment details.

HITCHING TO TRACTOR, CONT'D.THREE POINT HITCH ATTACHMENT

The conveyor hitch frame was designed to attach to a Category #2 three point hitch. The conveyor will adapt to a Category #3 three point hitch with the Optional Adapter Kit.

The top link attachment for the three point hitch is not used.

Figure A below shows how to attach a Category #2 three point hitch. Figure B shows how to attach to a Category #3 three point hitch.

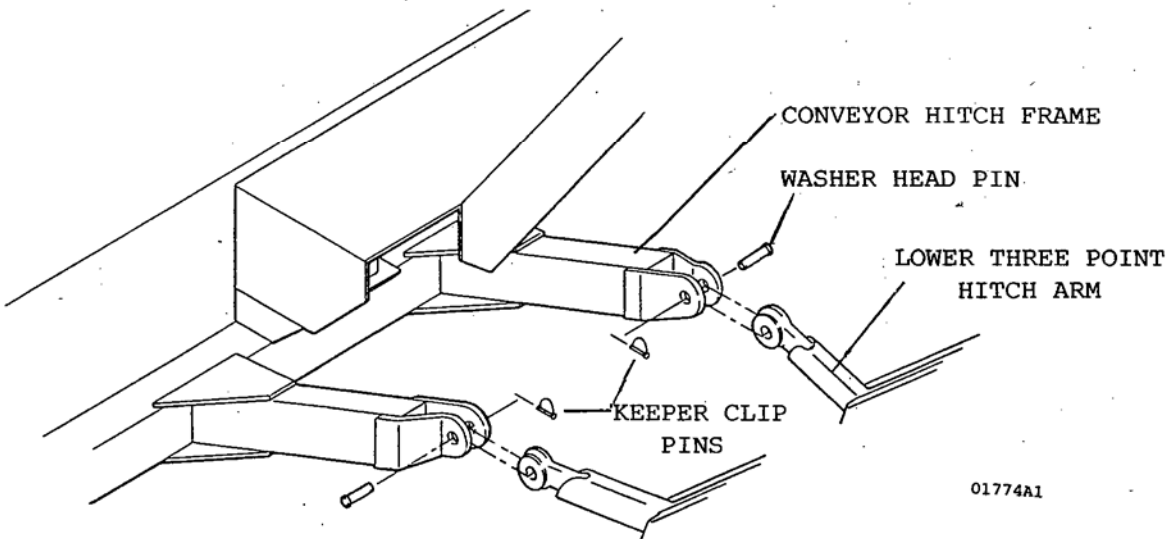

Figure A - Category #2

The lower three point hitch arms will mount between the ears, secured into place with washer head pins and keeper clip pins.

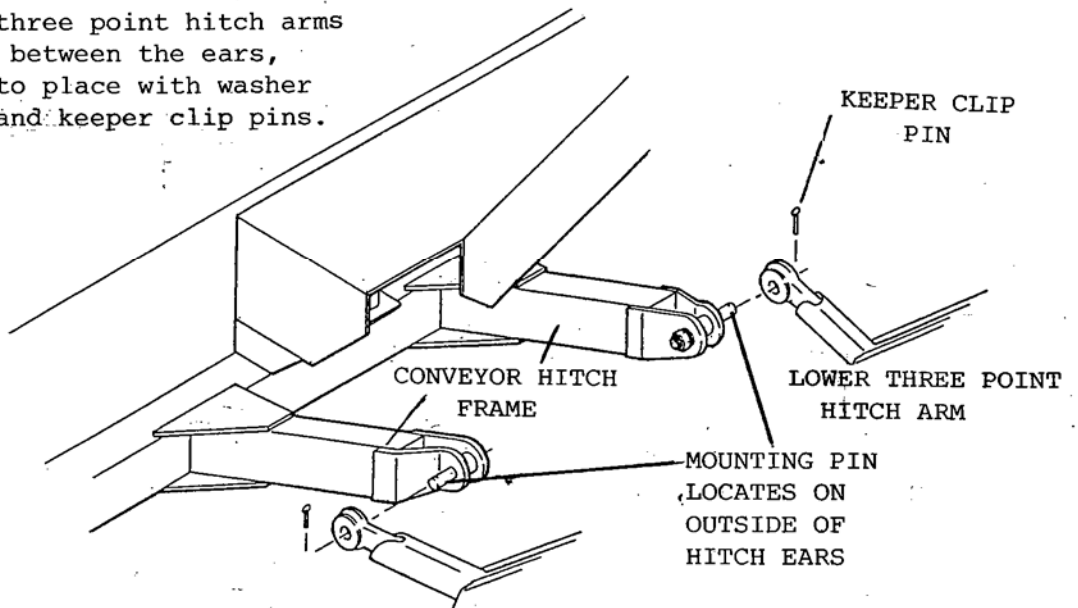

Figure B - Category #3

The lower three point hitch arms will mount on the outside of the hitch ears, secured into place with keeper clip pins.

HITCHING TO TRACTOR, CONT'D.INPUT DRIVE LINE ATTACHMENT

The Input Drive Line coupler furnished with the conveyor will fit the standard 1 3/8" x 6" spline PTO outlet shaft from a tractor (540 RPM).

1. Check inside the coupler to see if clear of dirt and other foreign objects.
2. Align the slots inside the coupler with those of the tractor's PTO Output Shaft. Push coupler onto the tractor's Output Shaft as far as it will go.
3. Push in the spring loaded release button and continue to slide the Input Drive Line onto the PTO Output Shaft. Release the button and check to see if Input Drive Line is securely fastened.

When the tractor and conveyor are hitched, the length of the PTO shaft, from knuckle-to-knuckle should never be longer than 33" and never shorter than 25". (See Figure below.)

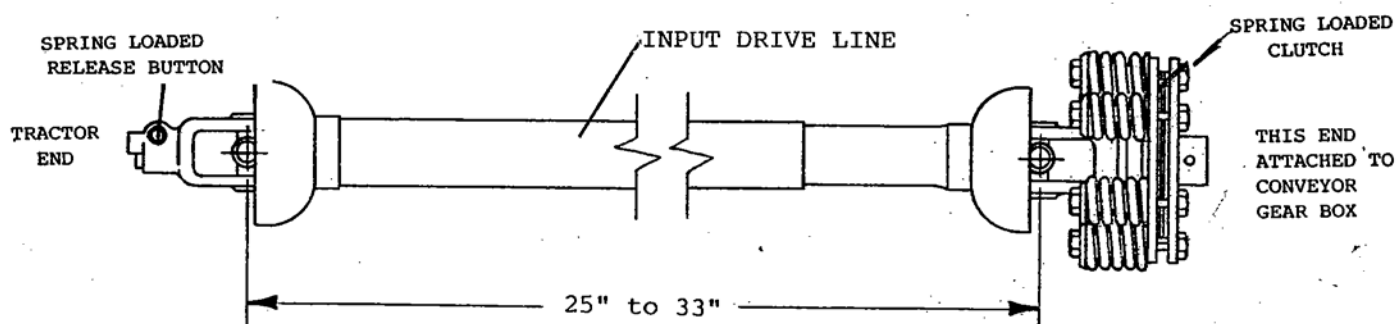

0769A1

CAUTION: Before operating this machine, be certain that the Input Drive Line shaft and slip clutch are securely attached to each other, and to the gear box and power source.



CAUTION: Before starting power source (tractor engine), be certain that the PTO is out of gear.

CAUTION: Never use an Input Drive Line without a rotating shield in good working order. Also see that the power drive system safety shields are in place at the gear box and the power source.

Page 8 HITCHING TO TRACTOR, CONT'D.HYDRAULIC INFORMATION

The tractor's hydraulic circuits for conveyor lifting must have an 1800 to 2000 PSI capacity.

The hydraulic components received with your Portable Conveyor were selected to deliver the most efficient and economical use. Any parts for replacement should be replaced with parts of the same type and size. Replace any hoses or fittings which develop leaks.

MAIN CONVEYOR LIFT SYSTEM

Standard equipment for your Portable Conveyor Lift System includes the hydraulic cylinder, fittings and a hydraulic line from the cylinder to the tractor, with the exception of the fitting required to attach hose to tractor. The fittings supplied include a restrictor that limits the speed of operation of the hydraulic cylinder. A 1/2" male pipe fitting is provided at the end of the hose leading to the tractor. A vent plug is located in the rod end of the hydraulic cylinder.

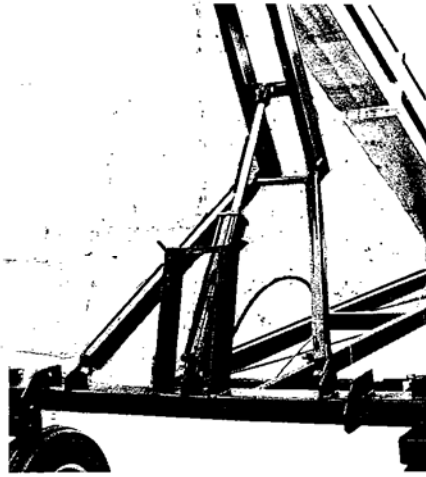

CAUTION: Do not connect or disconnect hydraulic components when there is pressure within the system. Hydraulic systems are highly pressurized. Escaping hydraulic oil, even an invisible pinhole leak, can penetrate body tissues and cause serious injury. Use a piece of wood or cardboard when looking for leaks. Never use the hands or other parts of the body. When reassembling, make absolutely certain that all connections are tight. If injured by hydraulic oil escaping under pressure, see a doctor immediately. Serious infection or reaction may occur if medical attention is not received at once.

WARNING: Keep all hydraulic lines away from moving parts.

OPTIONAL HYDRAULIC CONTROL DISCHARGE SPOUT

The equipment received with this optional hydraulic control discharge spout (illustrated) includes hydraulic cylinder, fittings and hydraulic lines from the cylinder to the tractor, with the exception of fittings required to attach hose to tractor.

A second hydraulic control discharge spout (not shown) is available that requires two hydraulic circuits. The spout adjusts up & down and also swivels back & forth.

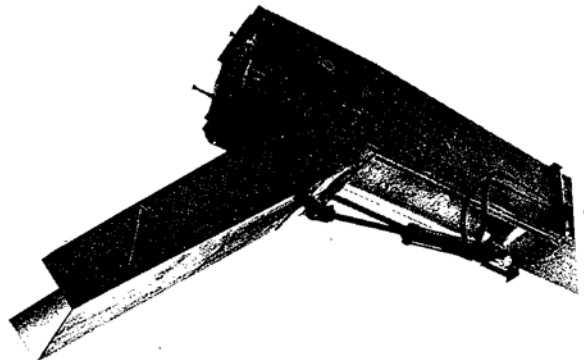

HITCHING TO TRACTOR, CONT'D.FRONT TRACTOR ATTACHMENT**IMPORTANT:**

The conveyor cannot be transported or maneuvered without being securely fastened to the front of the tractor.

The front tractor attachment mounts are not furnished as standard equipment with the conveyor. A number of front tractor mounts are available from Hutchinson if the tractor size and model is furnished.

If a front tractor mount was ordered with your conveyor, use the assembly instructions furnished with the mount. If not, the mount must be fabricated locally. Shown below are two ways the front attachment can be built. Be sure to use material and fasteners of a strength sufficient to hold the conveyor in place along side the tractor. Loads in this area can be quite high during maneuvering operations.

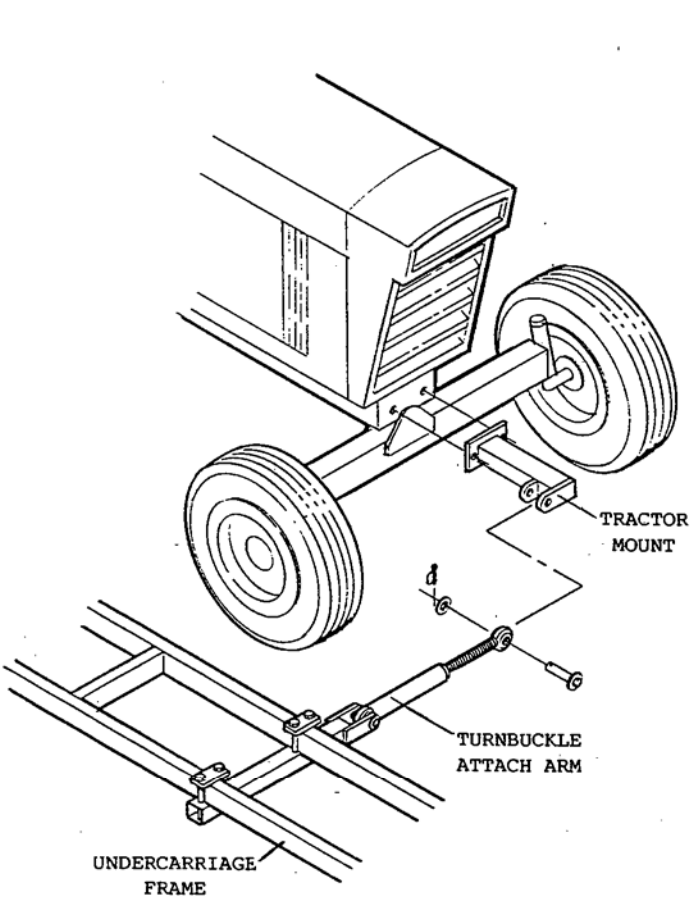

CASE
MODEL 970
(example)

01779A1

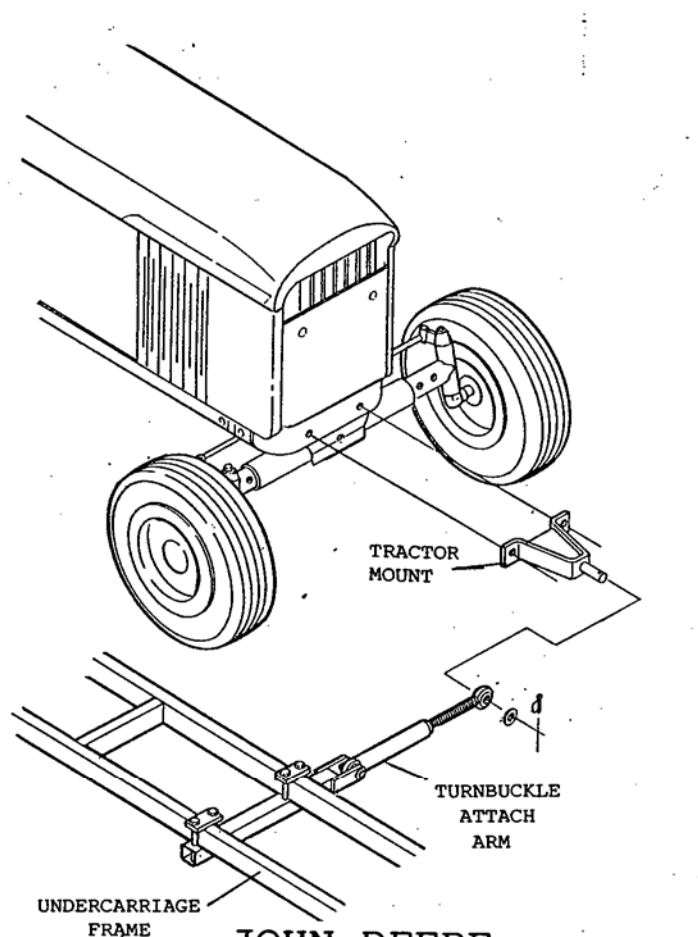

JOHN DEERE
MODEL 4020
(example)

01780A1

Adjust the turnbuckle attach arm so the conveyor is parallel with the tractor body. Be sure that the turnbuckle attach arm is located on the undercarriage so that the tractor tire will not hit the turnbuckle attach arm or any other part of undercarriage when making turns.

TRANSPORTING

Moving your portable conveyor requires careful planning. A route plan should be considered beforehand to avoid dangerous obstacles and loss of time. The conveyor must be transported with a tractor.

Follow these steps when transporting conveyor.

1. Completely lower discharge end of machine for transporting. See Fig. A.
2. Completely raise hopper end of conveyor. See Fig. A.

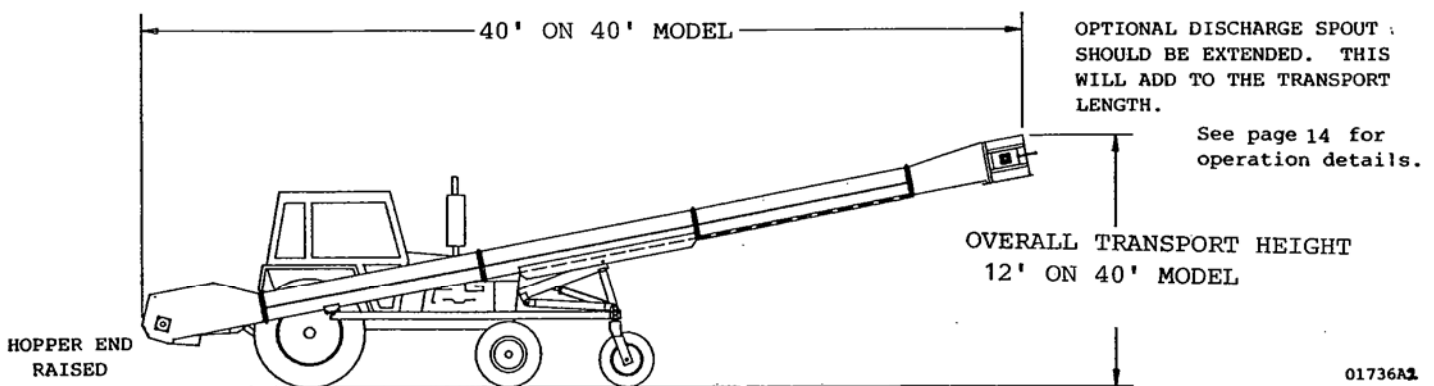
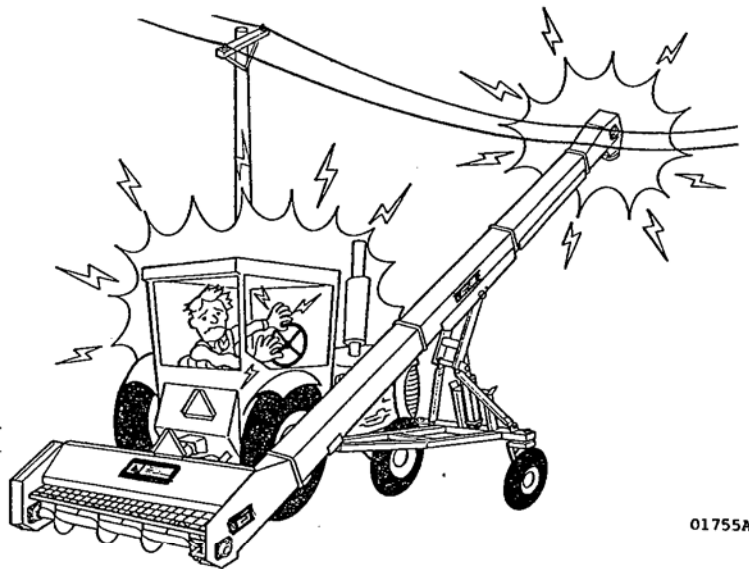

FIG. A
CONVEYOR IN TRANSPORT POSITION



Be alert to overhead obstructions and electrical wires. Failure to do so may result in electrocution. Completely lower conveyor well below level of power lines before moving. Maintain at least ten (10) feet of clearance. See Fig. A for the height of portable conveyor in the lowered transport position.

Never allow persons to stand underneath or ride on the conveyor when it is being transported.



Do not transport the conveyor at speeds in excess of 20 MPH and comply with your state and local regulations governing marking, towing and maximum width. Observe safe driving and operation practices.

Be aware the conveyor may affect the tractor handling during transport. Do not transport at speeds that cause difficulty in handling the tractor.

Do not engage the PTO when transporting conveyor.

SMV EMBLEM

We recommend that an SMV (Slow Moving Vehicle) emblem be attached at the rear of the conveyor. There is a place on the hopper for mounting the SMV emblem. Check your state and local laws regarding the placement and use of the SMV emblem.

DESIGNATED WORK AREA

Before starting the conveyor, a designated work area should be established and properly marked.

The following diagrams show the manufacturers designated work areas.

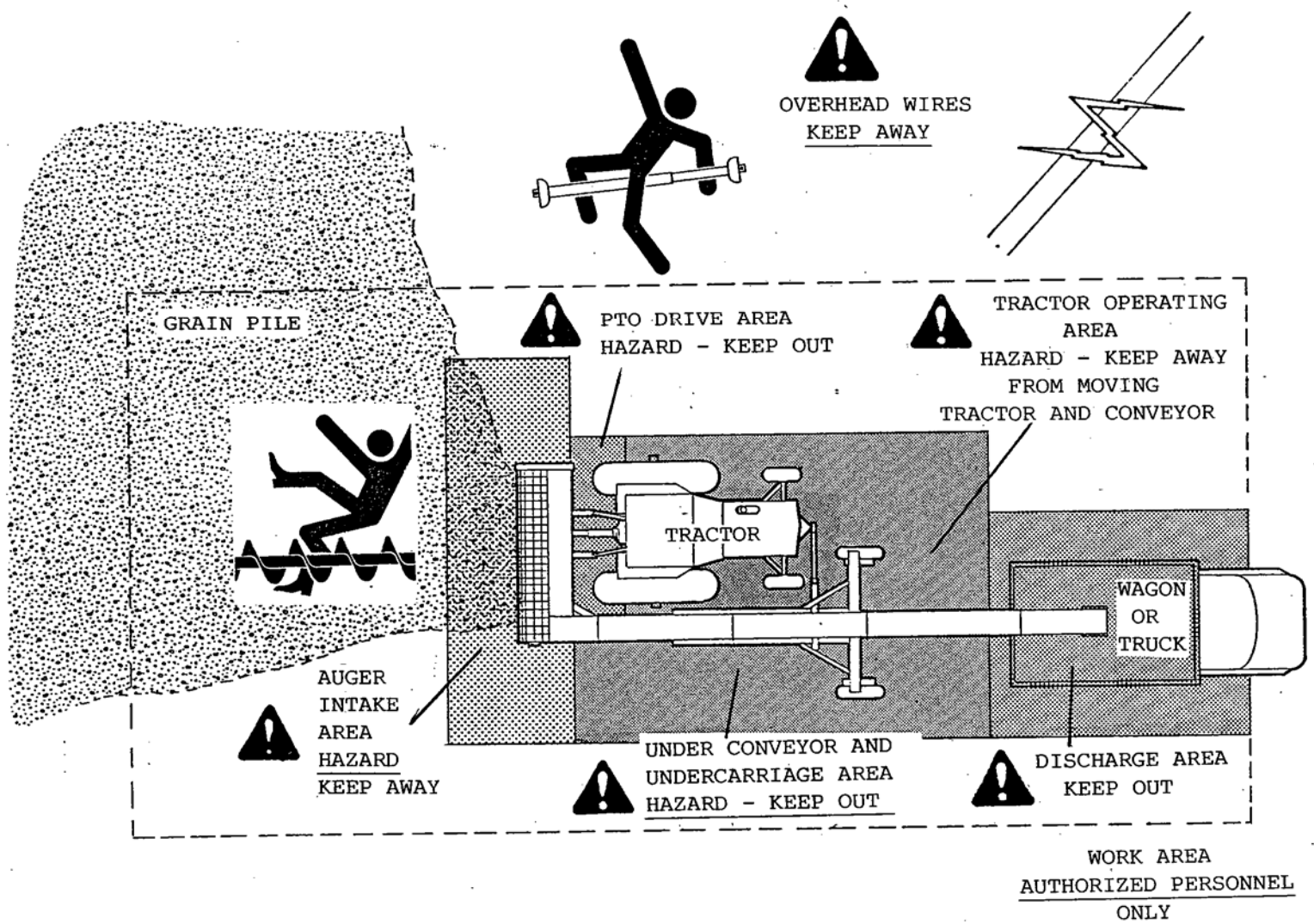
**RULES FOR SAFE WORK AREA**

Under no circumstances should persons not involved in the operation be allowed to trespass into the work area.

It shall be the duty of all operators to see that children and/or other persons stay out of the work areas! Trespass into the work area by anyone not involved in the actual operation, or trespass into a hazard area by anyone, shall result in an immediate shut down by the operator.

It shall be the responsibility of all operators to see that the work area has secure footing, is clean and free of all debris, and tools which cause accidental tripping and/or falling. It shall also be the operator's responsibility to keep the work area clean and orderly during the operation.

OPERATING

PLANNING

Before starting to load grain with your conveyor, carefully plan the direction and manner you will enter into the pile of grain. Remember to leave adequate room that will provide a convenient path for the vehicles which will be loaded with grain.

Beware of structures or other items buried under the grain that can cause damage to the conveyor. (Example - aeration equipment placed under the grain.)

Beware of overhead structures, such as ceiling beams or trusses inside a building, top of doorways and electrical lines.

Avoid penetrating or tunneling directly into the center of grain pile. Cascading grain may trap tractor or loading vehicle.

PREPARATION

Before starting the tractor, do a complete inspection of machine. See Page 5 for checklist.

START-UP



Before starting the tractor, be certain power to PTO is off. Stay out of designated hazard areas of an operating PTO and intake area. (See Work Area Diagrams on Page 11.) Keep all safety shields and devices in place. Keep off the equipment at all times.

1. Start tractor engine.
2. Back the conveyor next to pile of grain.
3. Lower hopper to the surface.
4. Check that the vehicle to be loaded is properly aligned under conveyor discharge.
5. Engage PTO at a slow RPM to minimize shock loads. Then work up recommended speed of 540 RPM.
6. Slowly back into grain pile.



KEEP AWAY FROM
ROTATING AUGER AND
MOVING CHAIN WITH
PADDLES.

Never operate the conveyor empty for any length of time as excessive wear will result.

When a conveyor is new or has been idle for a season, it should go through a "break in" period. It is important to operate the conveyor at reduced capacity for the first 1000 bushels until the housing and internal parts become polished. Operate at the recommended speed during this period. Operation at full capacity during this initial period will result in high power requirements.

OPERATING

FEEDING

Movement of the conveyor into the grain pile is largely a matter of operator choice.

It is not necessary to completely cover the intake auger to achieve full capacity. Avoid as much as possible completely covering the auger intake, as higher horsepower will be required.

Cascading grain will occasionally cover the auger. When this occurs, allow the conveyor to clear before continuing movement into the pile.

It is best to allow the hopper and conveyor to completely empty before stopping the unit. However, the unit will start under load. This will take more horsepower to start. Be sure to start at a low tractor RPM and then work up recommended RPM speed.

Allow the conveyor to go through a "break-in" period to polish the inside of housing before doing intermittent type operations.

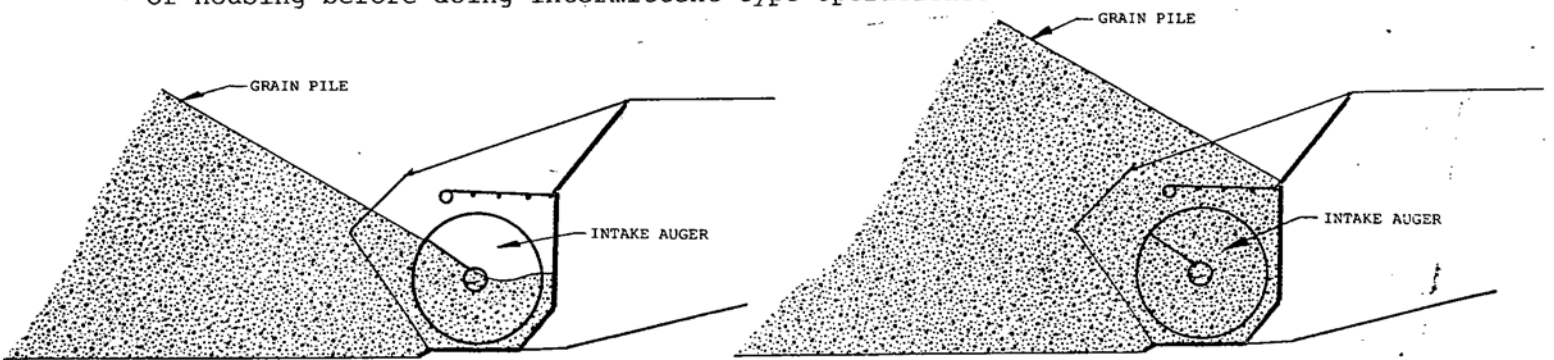

RECOMMENDED

HIGH HORSEPOWER REQUIRED

01771A1

01772A1

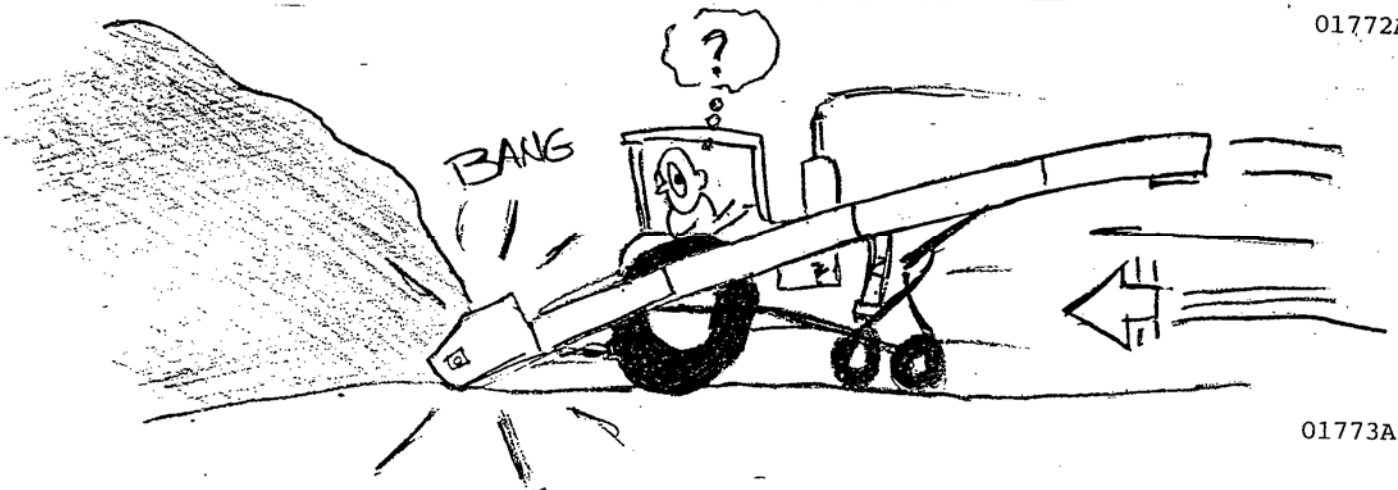

AVOID RAMMING GRAIN PILE

Do Not Attack or Ram the grain pile to achieve penetration, as this will likely cause damage to the unit.

While access to grain pile may be limited, it is a good practice whenever possible to work around the edges as opposed to penetrating directly toward the center of the pile.

OPERATING

OPTIONAL DISCHARGE SPOUT

Two optional hydraulically controlled discharge spouts are available. Each mounts directly onto the conveyor discharge. These devices allow the tractor operator to use a hydraulic cylinder when directing discharging grain flow. The operator should use care when using the spout to provide adequate clearance of spout over vehicles to be loaded.

ADJUSTABLE SPOUT

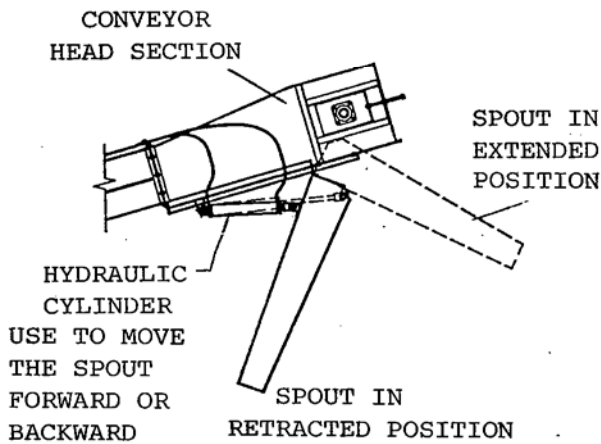

SWIVEL SPOUT

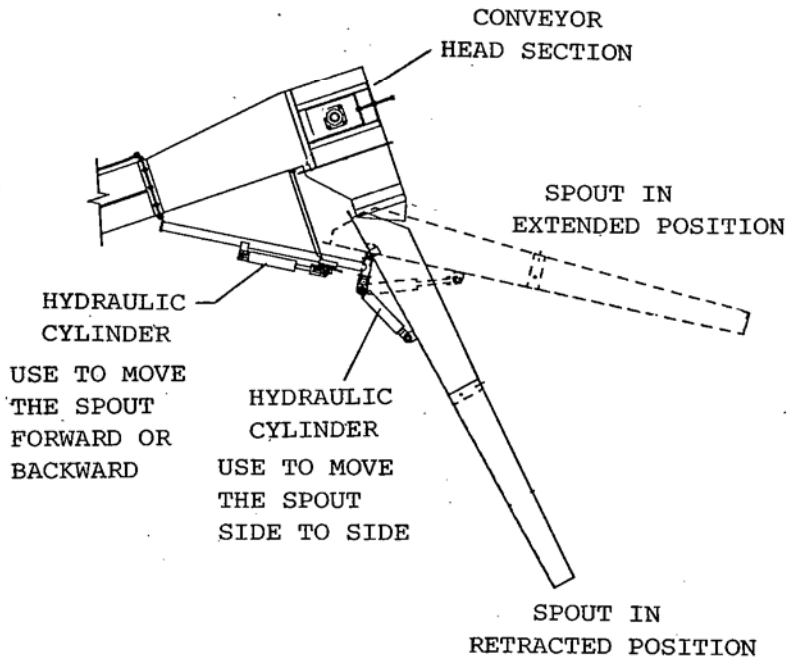

OPTIONAL INTAKE HOPPER

An optional intake hopper is available that will attach to the conveyor intake. Before using the optional intake hopper, check that the hopper is properly fastened to the conveyor intake and the safety screen is securely fastened. See Page 30 of this book. When using the optional intake hopper, the intake end of the conveyor must be resting on the ground. Place the tractor in park and set the brake. Never operate the conveyor without the tractor being completely hitched to the conveyor. See "Hitching to Tractor Instructions" on Page 5 to 9. Operate the conveyor at the recommended 540 RPM PTO speed. Under normal conditions, dry grain can be handled without controlling the flow of grain into the hopper. High moisture grain can cause increased horsepower requirements by as much as 40%.

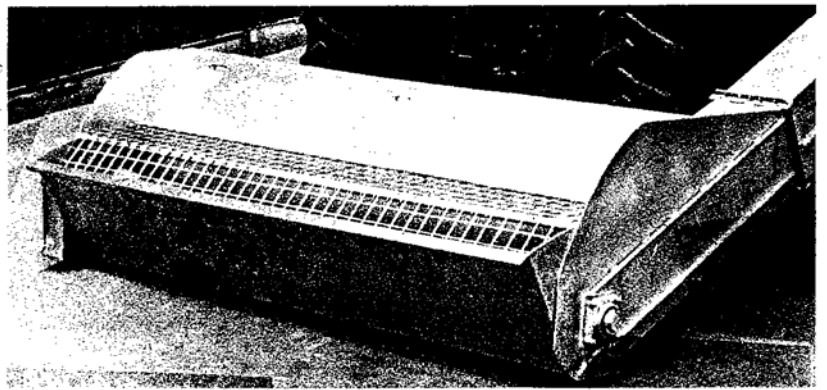

01759A1
01849A1

OPERATING

CAPACITIES

The results or capacities of conveyors can vary greatly under varying conditions. Different materials, moisture content, amounts of foreign matter, angle of operation, methods of feeding and speed all play a role in the performance of the conveyor. Twenty-five (25%) moisture could cut capacity back by as much as 40% under some conditions.

SHUTDOWN

A. Normal Shutdown

When shutting down the conveyor, make certain that the hopper and conveyor are empty before stopping the unit. Before the operator leaves the work area, the power source shall be locked out. (See Lockout).

B. Intermittent Operation Shutdown

It is best to allow the hopper and conveyor to completely empty before stopping the unit. However, the unit will start under load. This will take more horsepower to start. Be sure to start at a low tractor RPM and then work up recommended RPM speed.

Allow the conveyor to go through a "break-in" period to polish the inside of housing before doing intermittent type operations.

C. Emergency Shutdown

Should the conveyor be immediately shutdown under load and become jammed to where a restart is impossible, move the conveyor away from grain pile to allow grain to clear from intake hopper. Then attempt to restart. If restart is not possible, disconnect and lockout the power source. Clean as much grain from intake hopper and conveyor. Search for possible foreign matter plugged in hopper or conveyor. Clean obstruction and attempt restart.

LOCKOUT

If the operator must leave the work area, or whenever servicing or adjusting, the conveyor should be stopped and the tractor turned off. Precaution should be made to prevent anyone from operating the tractor or conveyor when the operator is absent from the work area.



Remove ignition key or coil wire from power source. (If this is impossible, remove the Input Drive Line from the work area.)

CLEAN-UP AND STORAGE

After the operation is completed and all machines have been shutdown, we recommend to do the following:

1. Clean entire work area. Be sure machine is empty.
2. If not in transport position, lower machine to the full down position immediately upon clearance of any obstructions.
3. Clean all grain and other foreign matter out of hopper area and off the machine.
4. Move the conveyor to next work or storage area. We recommend that the conveyor be stored in the full down position.
5. Unhitch conveyor from tractor.
6. Inspect the conveyor as outlined in the "Machine Inspection Section".



Whenever you must service or adjust your equipment, make sure you stop your engine and lockout your power source.

LUBRICATION & MAINTENANCE

NEVER CLEAN, ADJUST OR LUBRICATE A MACHINE THAT IS IN OPERATION.



Keep all safety shields and devices in place.

For economical and efficient operation of your conveyor maintain regular and correct lubrication. Neglect leads to reduced efficiency, excessive wear and needless down time.

The following lists the parts needing adjustments or lubrication and the various conditions which determine the time span.

CONVEYOR DRIVE CHAIN

It is important not to overtighten the conveyor chain. However, if the chain is not sufficiently tight, it will slip at the lower drive sprocket as capacity is increased. Should this occur, shut off the grain flow to the unit and shut down after the unit has emptied.

1. To check conveyor chain tension, grasp one of the paddles at the intake end and attempt to rotate it up toward the chain. See Figure A. Proper chain tension should allow only minimum rotation of the paddle, approximately 10 degrees. To adjust, go onto Step 2.
2. To either loosen or tighten the conveyor chain, loosen the four carriage bolts in desired direction. Jam nuts should be moved equal amounts so that head shaft remains straight. Check it by measuring from the shaft at each bearing to the head end. Limit the tightening process to 1/8" of travel. Restart the conveyor and operate normally. The tightening process may be repeated if necessary. Do not over tighten.
3. If chain is still too loose after these adjustments, it may be necessary to remove one or more links from the chain.
4. Tighten carriage bolts on take-up slides. Make sure main shaft is square with chain and trunking.

IMPORTANT: The life of the conveyor chain will be shortened when the chain is allowed to sit in water or is operated in acidic conditions, so avoid these situations. To extend chain life, spray a light coat of oil on the chain after each season's use. Use extreme caution; keep away from moving chain and paddles.

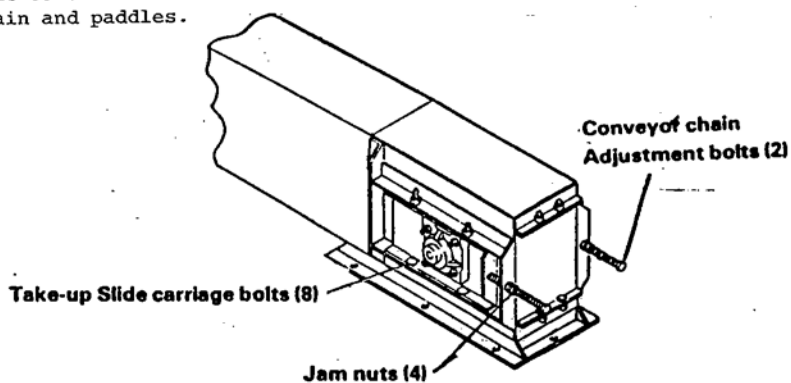
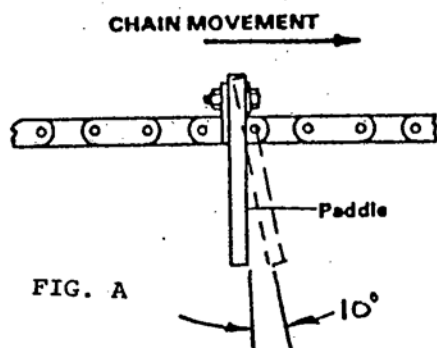
**BALL BEARING MAINTENANCE**

The head and hopper bearings are self-aligning, sealed ball bearings which have been packed at the factory. They should be lubricated at approximately fifty (50) hour intervals. Lubricate lightly with SAE multipurpose type grease. To lubricate the hopper hanger bearing, remove the lubrication plug and screw in a grease zerk. After lubrication, remove the zerk and reinstall the plug as normal operation will likely damage the zerk. There is no adjustment to be made to the bearings, but check that bearings are firmly fastened. Also check that the setscrews in the lock collars are tight against the shaft, securing the lock collars to the shaft.

Some bearings use an eccentric type lock collar. To tighten this type of lock collar, first slide it against cam end of the inner ring of the bearings. Engage cams by rotating collar until it slides over cammed end of the inner ring. Lock the collar by tapping in direction of shaft rotation. Tighten setscrew.

LUBRICATION & MAINTENANCE

INPUT DRIVE LINE

U-JOINTS

Input Drive Line u-joints should be lubricated at approximately ten (10) hour intervals with SAE multipurpose type grease.

SHIELDING

The outer PTO guards must turn freely and be properly attached and maintained.



DO NOT operate unless PTO guards, tractor master shield and implement guards are in place.

Check that the u-joint yokes are securely fastened to the tractor PTO and gear box shaft.

Before engaging PTO be sure that Input Drive Line shields turn freely.

GEARBOX

Before operation check gearbox oil level. Oil must reach the plug midway on the gearbox side. Use non-foaming, multipurpose gear oil, SAE 90 weight. Check and maintain the level regularly.

Assembly Instructions for the TORQMASTER Modular Clutch

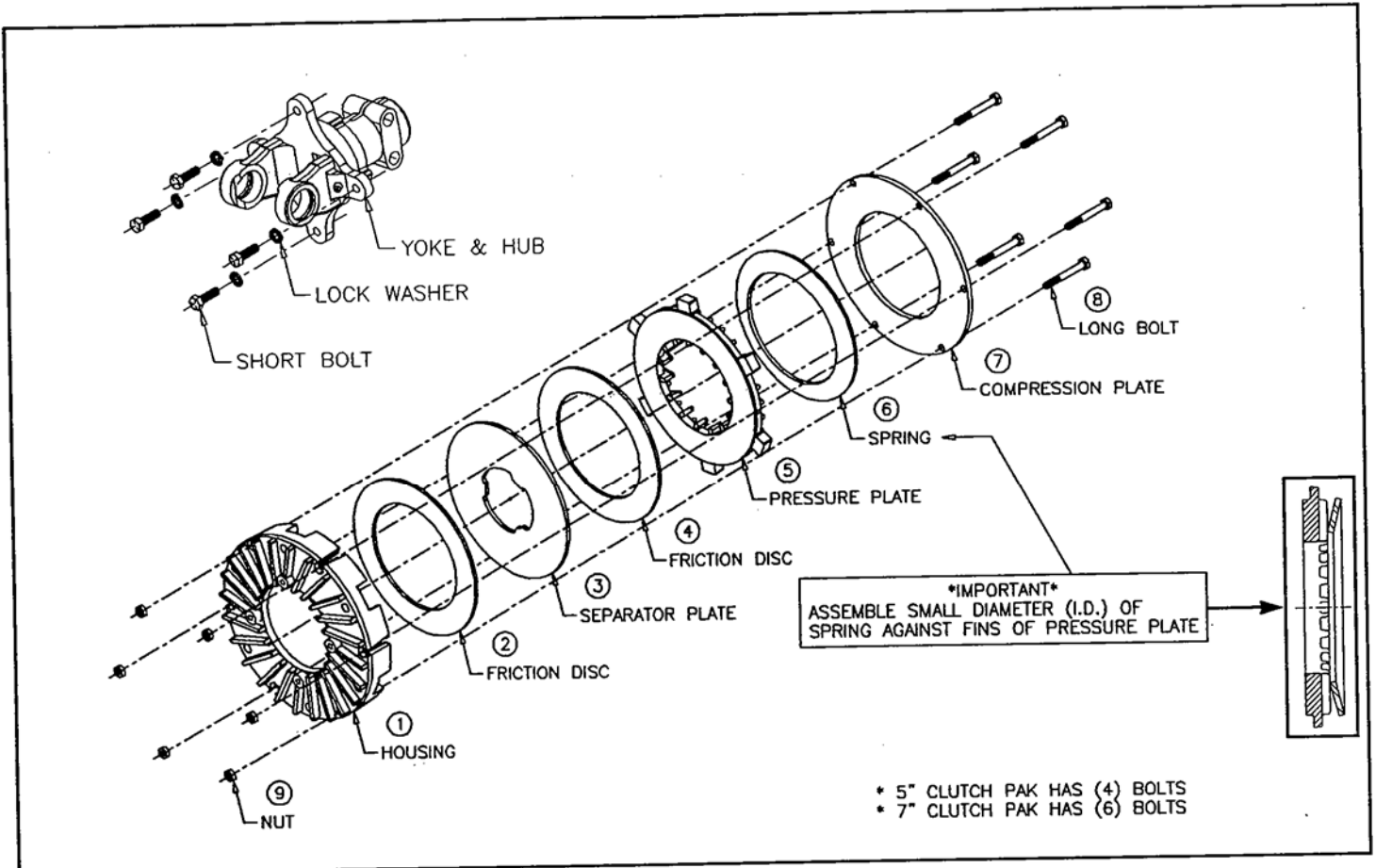

Run-In of the TORQMASTER Modular Clutch (Instruction)

If the clutch has not been operated for (1) season, we recommend the following:

TOOLS REQUIRED:

(1) 1/2" Box wrench or socket

1. Make sure the tractor is off and the PTO is disengaged.
2. Disconnect the driveline from the tractor.
3. Locate the bolts on the O.D. of the clutch pak. Loosen the bolts until all are finger tight, then tighten each one half a turn.
4. Attach the implement to the tractor at the hitch pin, and the driveline to the tractor PTO.
5. Turn the tractor on. Engage the PTO clutch and run for a few seconds, or until the clutch visibly smokes.
6. Disengage the tractor PTO and shut off the tractor.
7. Disconnect the driveline from the tractor.
8. Tighten the bolts on the O.D. of the clutch pak. If there are (4) bolts on the O.D. (5" clutch pak) make sure there is a 3/8" gap between the pressure plate tab and the compression plate. If there are (6) bolts on the O.D. (7" clutch pak), tighten the bolts until the compression plate is in full contact with the housing.
9. If the clutch contains an integral overrunning clutch, make sure the clutch spins freely in one direction.

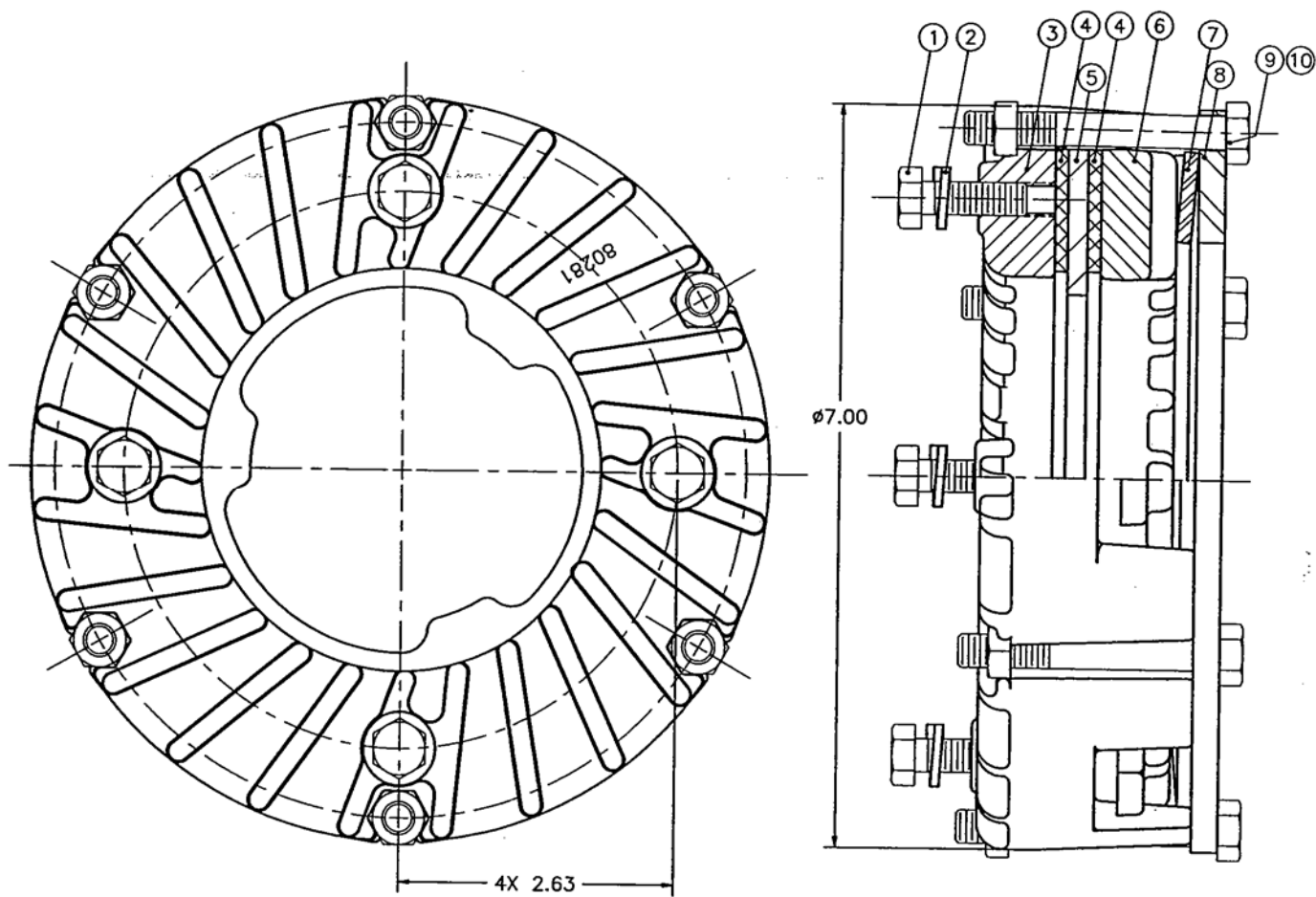

PARTS LIST			
ITEM	QTY.	WEASLER PART NUMBER	DESCRIPTION
1	4	11-10128	BOLT, .312-18 x 1.00 LG GRADE 5
2	4	11-15104	LOCK WASHER, .312
3	1	80281-1000	HOUSING
4	2	11-11167	FRICTION DISC
5	1	20-15133	SEPARATOR PLATE
6	1	80311-1000	PRESSURE PLATE
7	1	23-15039	SPRING
8	1	38-40075	COMPRESSION PLATE
9	6	11-10471	BOLT, .312-18 x 2.50 LG GRADE 5
10	6	11-10269	NUT, .312-18

LUBRICATION & MAINTENANCEUNDERCARRIAGE AXLE SPINDLE BEARINGS

Tapered roller type bearings are standard for portable conveyors and should be repacked with grease and adjusted annually or as needed, determined by usage.

Care must be used in dismantling wheel bearing assemblies. First remove the dust cap by prying around its edges. Remove the cotter pin, slotted nut and flat washer. Carefully remove the hub and bearings from the spindle. Inspect all parts for wear or damage and replace with new ones if necessary.

When reassembling the hub, repack both bearing cones with grease and fill the hub cavity 1/3 full. Place inner bearing assemblies into the hub and then press seal into hub and carefully reinstall the hub on the spindle. When placing hub on spindle, be careful not to damage the lip of the grease seal. Install outer bearing assembly into the hub and replace flat washer and slotted nut. Then tighten the slotted nut to seal the bearings until the hub binds as you rotate hub. Back off the slotted nut to the next slot and place a new cotter pin in. Use a 5/32" cotter pin x 1 1/4" long. Replace dust cap.

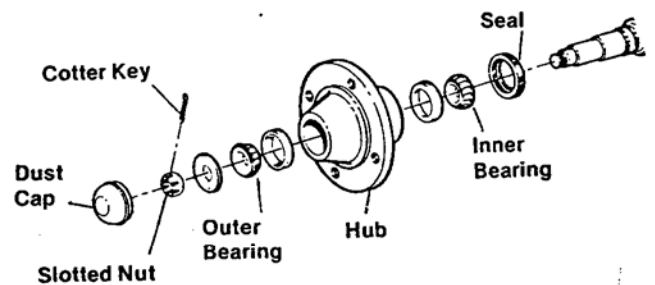

VERTICAL PIVOT POST
ON UNDERCARRIAGE CASTER

CASTER WHEEL POST

The vertical pivot post on the undercarriage caster is equipped with a grease zerk, lubricated at approximately ten (10) hour intervals with grease.

GREASE ZERK

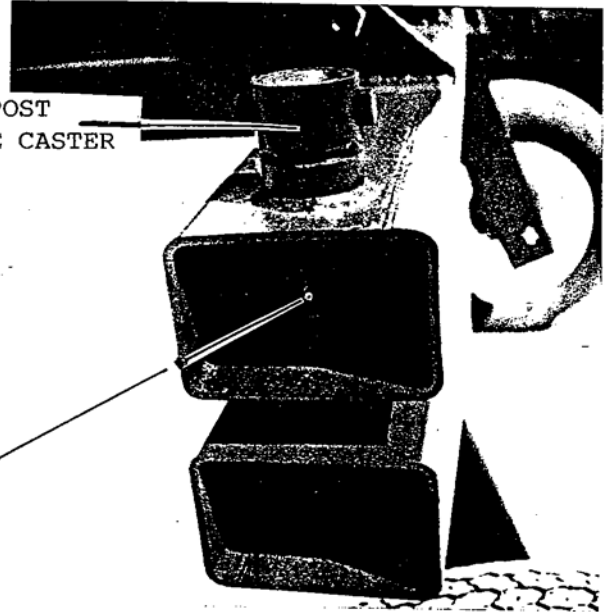
HYDRAULIC HOSE AND FITTINGS

Check all hydraulic hoses, fittings and tubing to see that they are tight and not leaking hydraulic oil. Replace any hydraulic components that are damaged or leaking. Check hose and tubing mounts. They should be securely fastened to conveyor. Be sure hoses are routed to avoid all moving parts.



CAUTION: Do not connect or disconnect hydraulic components when there is pressure within the system. Hydraulic systems are highly pressurized. Escaping hydraulic oil, even an invisible pinhole leak, can penetrate body tissues and cause serious injury. Use a piece of wood or cardboard when looking for leaks. Never use the hands or other parts of the body. When reassembling, make absolutely certain that all connections are tight. If injured by hydraulic oil escaping under pressure, see a doctor immediately. Serious infection or reaction may occur if medical attention is not received at once.

DRIVE CHAIN TENSION

The drive chain located on the left hand side of the hopper should be lubricated periodically and kept properly adjusted, to reduce wear on chain and drive sprockets. A spring loaded chain tightener is included on the conveyor. If the chain and sprockets are badly worn, they should be replaced for smoother operation. Check to see if drive sprockets are properly aligned with each other and with idler sprocket. Clear away any trash or foreign objects that may have accumulated around the chain and drive sprockets.

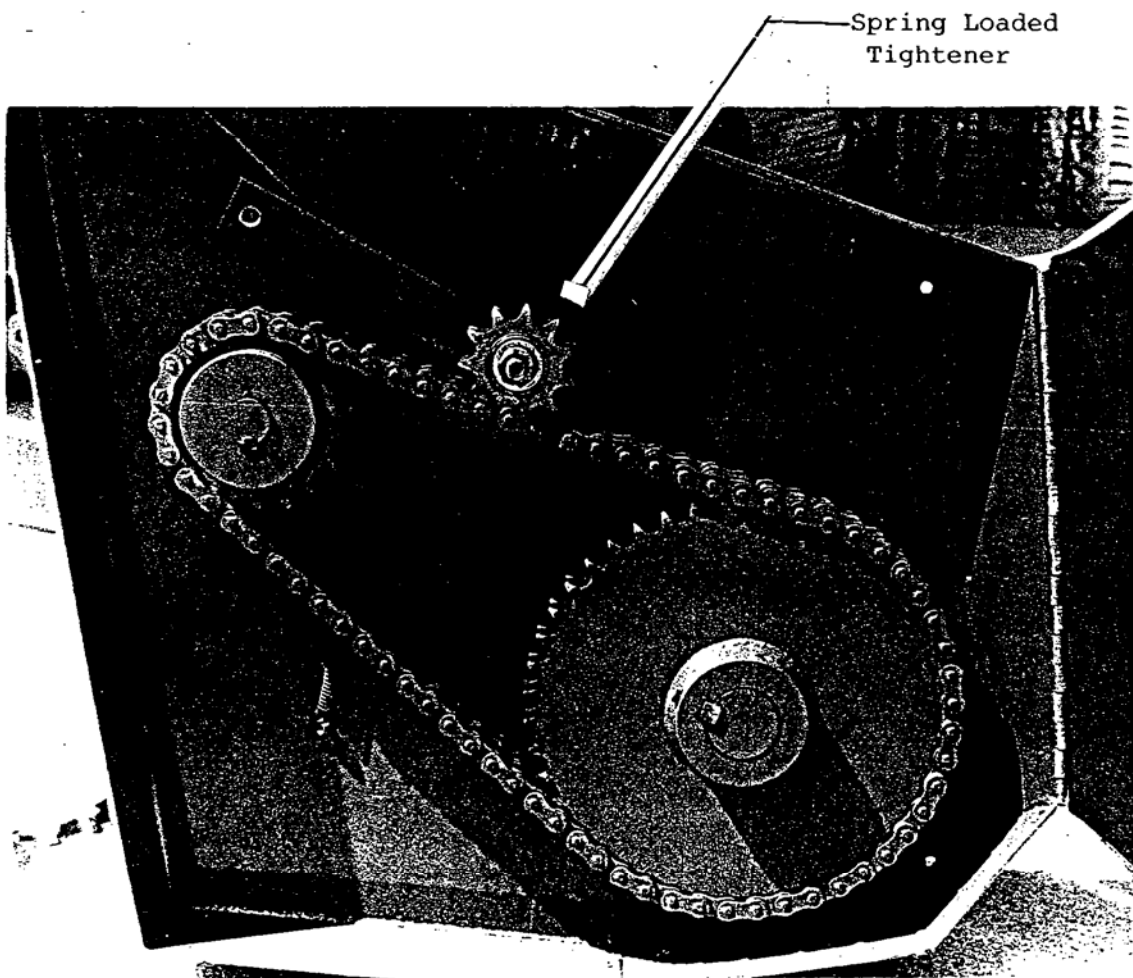
CHAIN GUARD

Check the chain guard to see that the latches hold the guard door securely closed. Guard should not rub against drive sprockets or chain. Immediately replace any worn or damaged guards. Clear away any trash or foreign objects inside the chain guard.

Page 20 TROUBLE SHOOTING

Conveyor lowering by itself

Check all hydraulic fittings and connections for leaks. Check the hydraulic hose for leaks.

Conveyor lowering or raising too fast

A restrictor fitting should be installed at the cylinder. This limits the speed of operation. Check the assembly manual to see if the fitting is installed properly. Check for a leak in the hydraulic line.

Conveyor will not raise or lower

See if the hydraulic coupler is properly attached to the tractor and the tractor reservoir is full of oil.

Excessive Intake Auger Noise

1. The hopper may be pushed into rotating auger.
2. Is the auger free of any foreign material.
3. Damage to the auger may have occurred, causing interference with the hopper.

Extreme noise from conveyor housing

1. Conveyor chain too loose. Check chain tension and adjust if necessary. See Page 16.
2. Improper assembly or misalignment of trunking. Locate trunking connection(s) that are source of noise and disassemble. Check for end smoothness and grind if necessary. Check for correct alignment of center divider. See Page 23.

Grain returning to the intake end through the top of the trunking.

1. Partially blocked discharge. Remove obstruction.

Paddles breaking or bending.

1. Paddles may be coming loose from the chain. Keep paddles securely connected to chain.
2. Frequent starts under load. Allow machine to clean out before shutting down.
3. Trunk misalignment. See Page 23 for correct trunk assembly.
4. Sprockets at intake or discharge ends may be off center. Align in center to trunking.
5. Overfeeding. Adjust the feeding of the unit to allow less grain to enter while maintaining full speed.

Low Capacity

1. Check the conveyor speed. Run the PTO at 540 RPM. The horizontal auger will run approximately 110 RPM.
2. Is the intake auger free of foreign material.
3. Grain is high in moisture. A lower capacity will likely be achieved with high moisture grain. Excessive feeding of high moisture grain can cause plugging.
4. Restriction at the conveyor intake where the chain the paddles start to move the grain into trunking.
5. Input Drive Line clutch slipping. Adjust clutch as recommended on Page 17.

SAFETY AND MAINTENANCE DECALS



CAUTION Keep all safety decals clean and readable. If a decal cannot be easily read for any reason, or has been painted over, replace it immediately. Decals may be ordered through your Hutchinson dealer.

CAUTION

1. READ AND UNDERSTAND THE OPERATOR'S MANUAL BEFORE OPERATING.
2. DO NOT REMOVE OR MODIFY SAFETY SHIELDS OR DEVICES.
3. DO NOT OPERATE OR MOVE THE MACHINE UNLESS VISITORS, CHILDREN AND ALL OTHER UNTRAINED PERSONNEL ARE WELL CLEAR OF THE MACHINE AND WORK AREA.
4. KEEP HANDS, FEET AND CLOTHING AWAY FROM MOVING PARTS.
5. STOP THE MACHINE, LOCK OUT POWER AND COMPLETELY LOWER THE MACHINE TO GROUND, DISCONNECT, BEFORE MAINTENANCE.
6. NEVER STAND BETWEEN TRACTOR AND MACHINE WHEN HITTING UNLESS ALL CONTROLS ARE IN NEUTRAL AND THE BRAKE LOCKED.
7. COMPLETELY LOWER DISCHARGE END OF MACHINE FOR TRANSPORTING.
8. COMPLETELY LOWER MACHINE BEFORE DISCONNECTING FROM TRACTOR.
9. TRANSPORT ON PULSIS PAVES. OBSERVE FEDERAL, STATE AND LOCAL REGULATIONS AND DISPLAY DAY LICENSE.
10. DO NOT DISCONNECT HYDRAULICALLY OPERATING COMPONENTS WHEN THERE IS PRESSURE WITHIN THOSE COMPONENTS.

PART NO. 34550 Caution (yellow & black) (8 1/4" x 10")

DANGER

ROTATING DRIVE LINE

FAILURE TO HEED THESE WARNINGS MAY RESULT IN PERSONAL INJURY OR DEATH.

KEEP HANDS, HAIR, CLOTHING, YOURSELF AND OTHERS WELL CLEAR.

DO NOT OPERATE UNLESS PTO GUARDS, TRACTOR MASTER SHIELD AND IMPLEMENT GUARDS ARE IN PLACE.

PTO GUARDS MUST TURN FREELY AND BE PROPERLY ATTACHED AND MAINTAINED.

HAZARD ZONES MUST BE SECURELY LOCKED ONTO TRACTOR AND SUPPLEMENT SHIELD.

KEEP PTO IN A CLOSED POSITION AS MUCH AS POSSIBLE.

KEEP JOINT ANGLES EQUAL.

PART NO. 34503 DANGER "ROTATING DRIVE LINE" (red and white) 4" x 5 1/2"

DANGER

BEWARE OF POWER LINES

ELECTROCUTION HAZARD

1. THIS MACHINE IS NOT INSULATED.
2. KEEP AT LEAST 10 FEET AWAY FROM OVERHEAD ELECTRICAL WIRES.
3. ELECTROCUTION CAN OCCUR WITHOUT DIRECT CONTACT.

FAILURE TO DO SO WILL RESULT IN SERIOUS INJURY OR DEATH!

PART NO. 34547 DANGER "BEWARE OF POWER LINE" (red and white) 7" x 9 7/8"

NOTICE:

OPERATOR'S MANUAL ENCLOSED

READ AND UNDERSTAND THE OPERATOR'S MANUAL BEFORE OPERATING.

IF THE OPERATOR'S MANUAL IS MISSING, ORDER MANUAL NUMBER 34550.

FREE OF CHARGE FROM HUTCHINSON DIVISION, 514 WEST CRAWFORD, CLAY CENTER, KS 67432.

PART NO. 34555 Notice (white and black) (2 13/16" x 6 3/32")

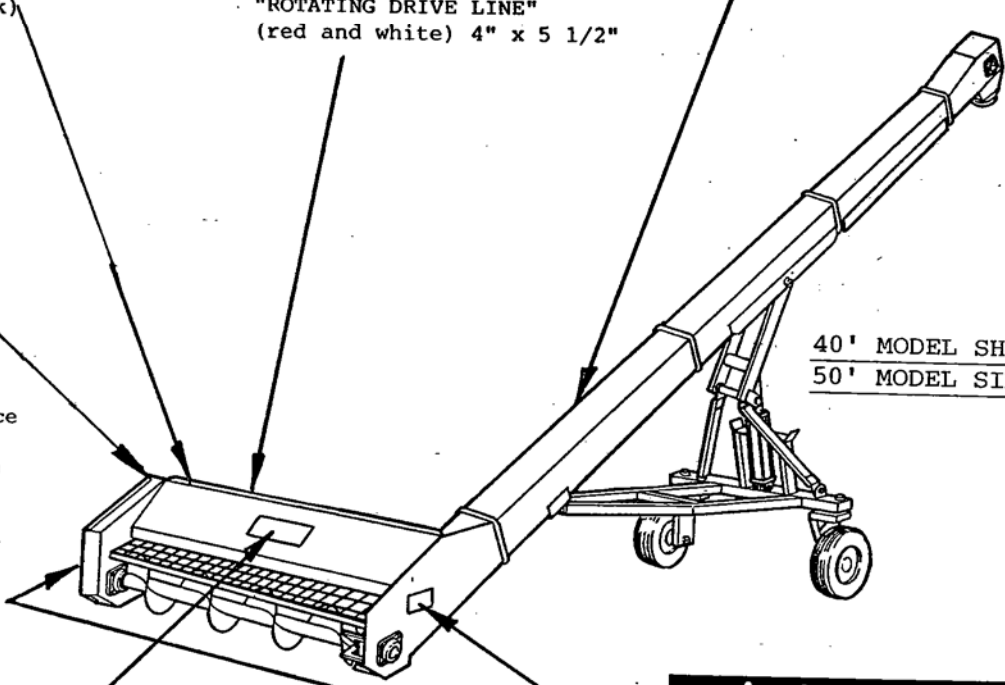

40' MODEL SHOWN
50' MODEL SIMILAR

DANGER

KEEP AWAY FROM ROTATING AUGER AND MOVING CHAIN WITH PADDLES.

FAILURE TO DO SO WILL RESULT IN SERIOUS INJURY OR DEATH!

PART NO. 34549 DANGER "KEEP AWAY FROM ROTATING..." (red and white 8 5/8" x 16 5/8")

DANGER

KEEP AWAY FROM ROTATING AUGER AND MOVING CHAIN WITH PADDLES.

FAILURE TO DO SO WILL RESULT IN SERIOUS INJURY OR DEATH!

PART NO. 34548 DANGER "KEEP AWAY FROM ROTATING..." (red and white) 5 1/2" x 10 5/8" (One located on both outside surfaces of hopper)

Hutchinson portable conveyors are well made and we are proud of our line of equipment. We would like you, as our customer, to do your part in using caution and good judgement in using our equipment as well as any other machinery. Any parts for replacement should be replaced with parts of the same type and size. Do not modify or alter any of the portable conveyor components.

DIMENSIONS

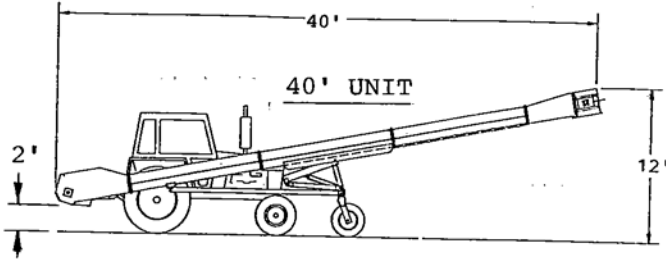

SIDE VIEW IN TRANSPORT POSITION

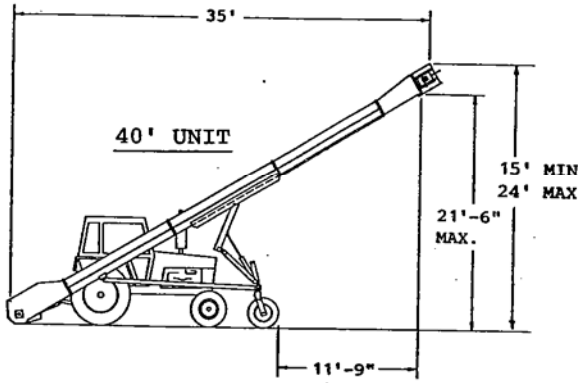

SIDE VIEW IN LOADING POSITION

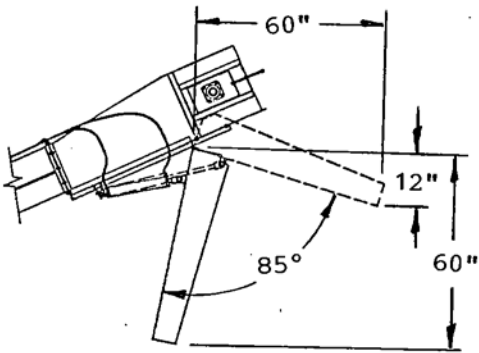

OPTIONAL HYDRAULIC ADJUSTABLE SPOUT (MT9011 & MT9012)

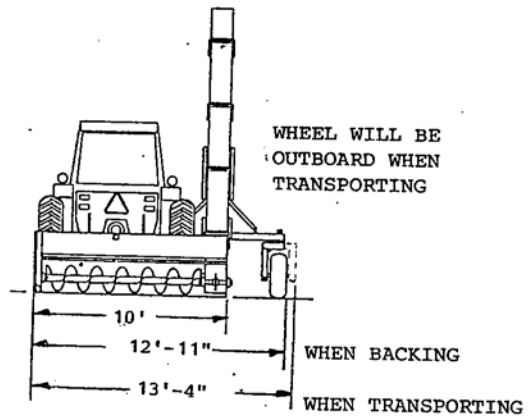

BACK VIEW

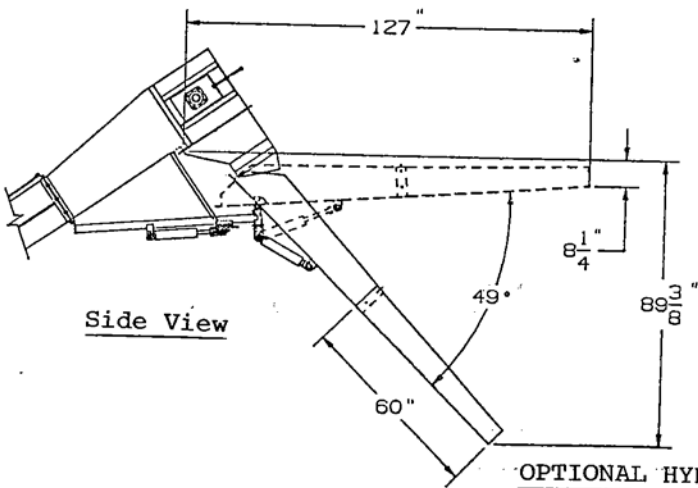

Side View

OPTIONAL HYDRAULIC SWIVEL SPOUT (MT9013 & MT9014)

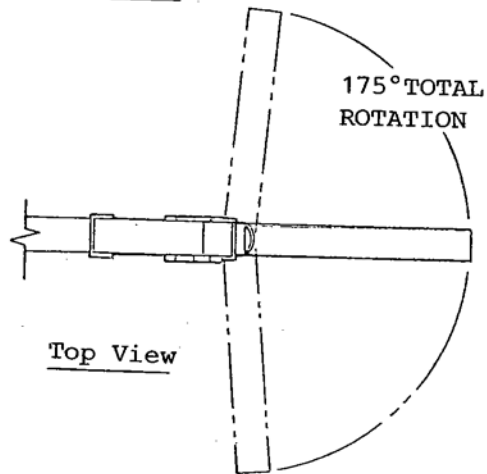

Top View

ASSEMBLY INSTRUCTION

It is very important that a new unit be properly set-up, adjusted and lubricated before use. Follow the illustrations on the following pages for proper set-up. Remove paint from grease fittings and replace any that are damaged or missing. Use lock washers and flat washers where called for. Spread all cotter pins.

Gearbox

The gearbox is shipped without oil. At field assembly of auger, 90° E.P. (non-foaming) oil is to be added to the gearbox until half full. Check and maintain the level regularly.

TRUNKING ASSEMBLY

Assemble on a level surface spacious enough to accommodate the unit when laid out full length. Assembly area should have access to a chain hoist or other lifting device.

Use 3/8" x 1" grade 5 bolts with lock washers and nuts to join trunking and to attach head to trunking.

40' MODEL

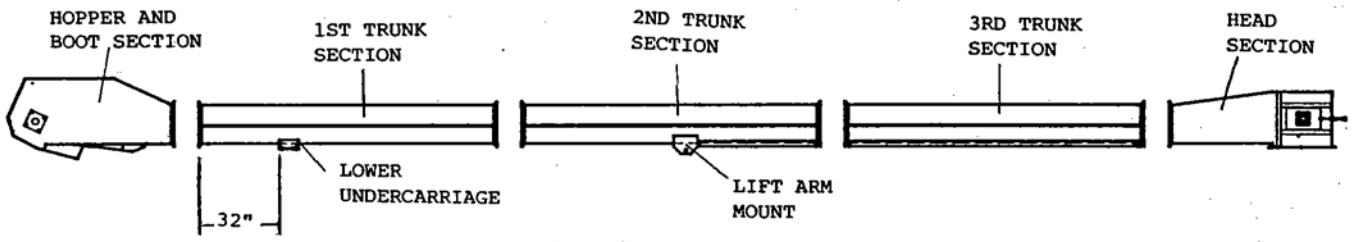

01760A1

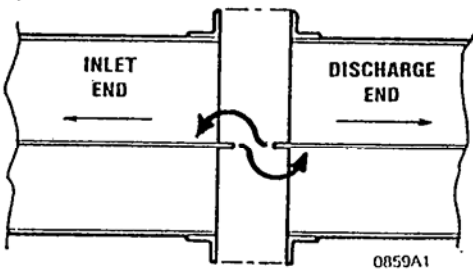

0059A1

IMPORTANT
OVERLAP CENTER PARTITION
AS SHOWN

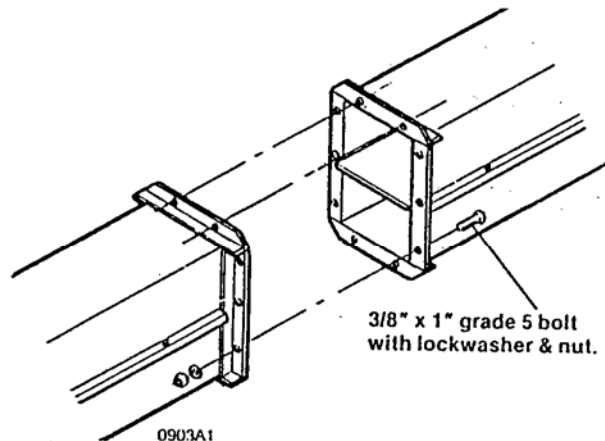

0903A1

TYPICAL TRUNK ASSEMBLY

CONVEYOR CHAIN AND PADDLE ASSEMBLY

The paddles can be assembled to the conveyor chain before installing the chain into the housing. Fasten the paddles and reinforcing plates to the chain attachments as shown. The metal reinforcing plate is placed between the chain attachment and the plastic paddle. Use two 5/16" x 1 1/2" long hex head capscrews in the center two holes, each with two flat washers and a locknut. Use two 5/16" x 1 1/4" long hex head capscrews in the two outside holes, each with one flat washer on the plastic side and a locknut.

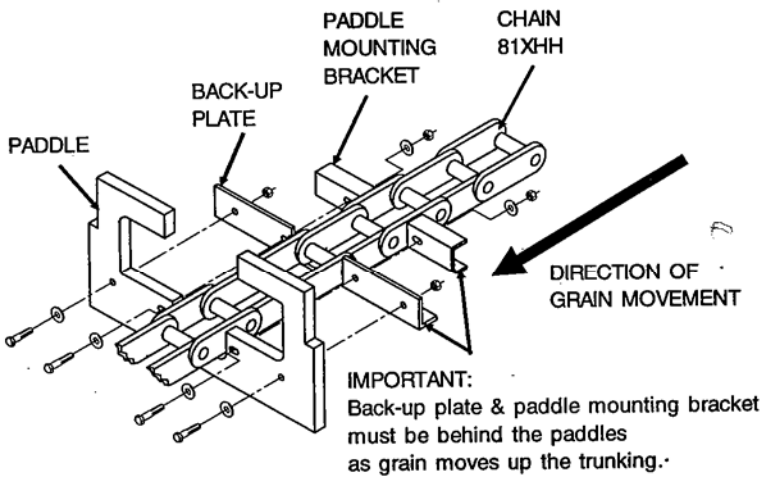

Insert chain and paddles through trunking and around main sprockets at ends. Join with connecting link.

NOTE: See Page 16 for conveyor chain tension adjustment.

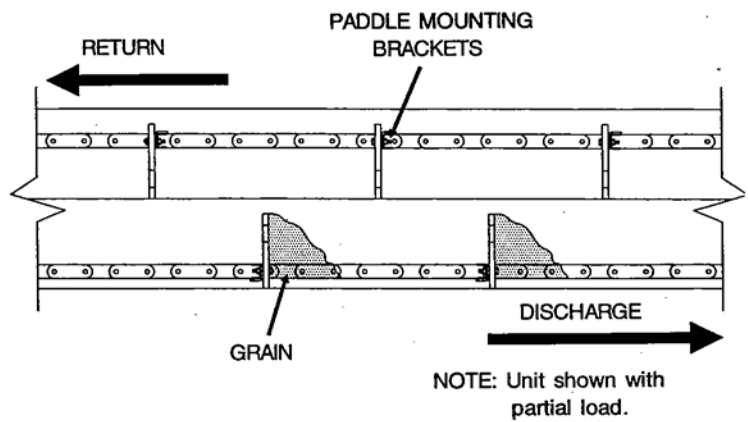

IMPORTANT SERVICE - MAINTENANCE NOTICE:

The life of the conveyor chain will be shortened when the chain is allowed to sit in water or is operated in acidic conditions, so avoid these situations. To extend chain life, spray a light coat of oil on the chain after each season's use. Use extreme caution; keep away from moving chain and paddles.

SPINDLES AND HUBS

When assembling the bearing hub pack both bearing cones with grease and fill the hub cavity one third full. Place inner bearing assemblies into the hub, then press grease seal into hub and carefully reinstall the hub on the spindle. When placing hub on spindle, be careful not to damage the lip of the grease seal. Install outer bearing assembly into the hub. Then slide flat washer on and install nut. Tighten the slotted nut to seat the bearings until the hub binds as you rotate hub. Back-off the slotted nut to the next slot and place a cotter pin in. Install dust cap.

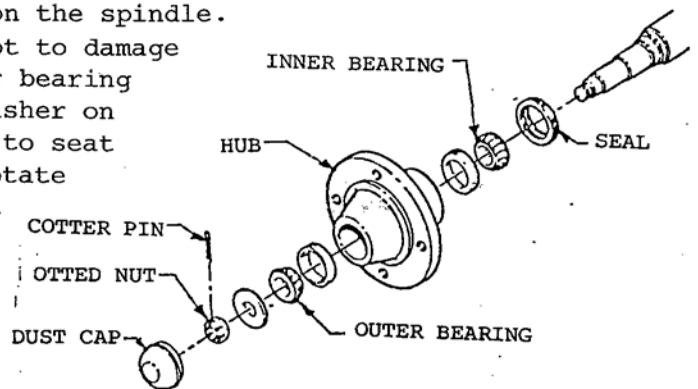

Undercarriage Assembly

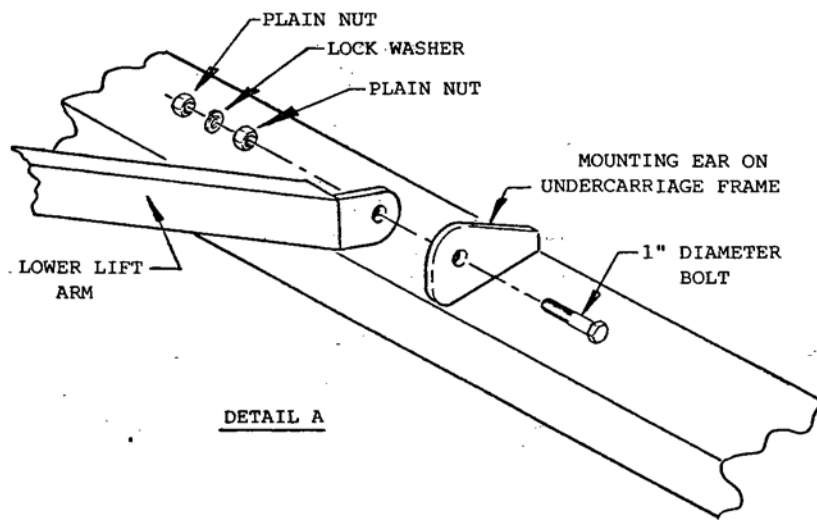
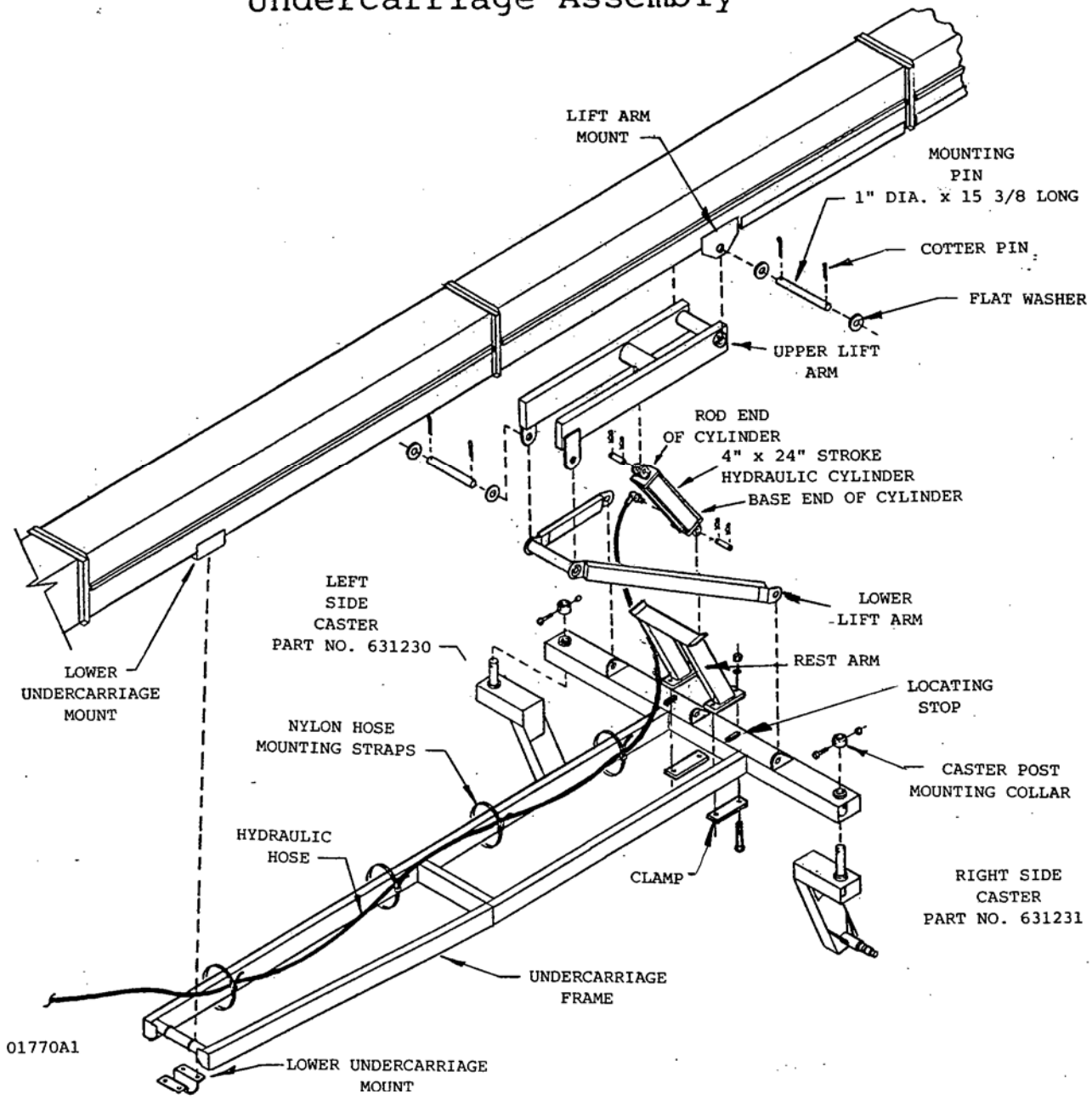

Undercarriage Assembly

1. Mount tires onto wheel rim, then mount tires and wheels onto the undercarriage casters.
2. Attach caster to the undercarriage frame using a post mounting collar to secure caster in place. Use 1/2" x 3" long bolt and lock nut to secure mounting collar to vertical caster post.
NOTE: There are right hand and left hand casters. See the part no. stenciled on the caster to determine its proper location.
3. Bolt lower lift arm to the undercarriage frame using 1" diameter bolt with plain nut, then slide on a lock washer and plain nut. See Detail A.
4. Bolt the rest arm between locating stops on the undercarriage frame using two clamp plates and four 3/4" x 6" long hex head bolts with lock washers and nuts.
5. Connect the upper lift arm frame to the lower lift arm frame using 1" dia. x 15 3/8" long pin with flat washers and 1/4" cotter pins.
6. Install the base end of the hydraulic cylinder to the mount on the undercarriage frame using cylinder mounting pin provided in cylinder.
7. Install the rod end of the cylinder to upper lift arm frame using cylinder mounting pin provided in cylinder.
8. Lift the conveyor trunk assembly high enough to roll the undercarriage frame under the conveyor so the lower undercarriage mount can be attached.
NOTE: Lift at a point near the center of the conveyor with a hoist or other safe, suitable means; DO NOT lift the entire weight of the conveyor from the extreme end. Use a sling completely around conveyor trunking assembly for lifting.

Use four 1/2" x 1 3/4" lg. (grade 5) hex head bolts with lock washers and nuts for lower undercarriage mount connection.
9. Connect the upper lift arm frame to the mount on the conveyor trunking using a 1" x 15 3/8" long pin with flat washers and 1/4" cotter pins.
10. Attach the elbow fitting of the 25'-0" long hydraulic hose to the port in the BASE END of the hydraulic cylinder.
IMPORTANT: The elbow fitting is equipped with a flow restrictor to limit the speed that the unit is raised or lowered.
DO NOT REPLACE THIS FITTING WITH A PLAIN ELBOW OR OTHER FITTING.
11. Route the hydraulic hose along the inside of the undercarriage frame tube. Secure the hose in four places along the frame tube using nylon straps. Then route the hydraulic hose through the u-shape loops on the hopper frame.
12. Check all fittings and connections to see if tight.
NOTE: There is a 1 1/2" male pipe fitting at the end of the hose leading to the tractor. The fitting required to attach the hose to the tractor is not furnished.



CAUTION Do not connect or disconnect hydraulic components when there is pressure within the system. Hydraulic systems are highly pressurized. Escaping hydraulic oil, even an invisible pinhole leak, can penetrate body tissues and cause serious injury. Use a piece of wood or cardboard when looking for leaks. Never use the hands or other parts of the body. When reassembling, make absolutely certain that all connections are tight. If injured by hydraulic oil escaping under pressure, see a doctor immediately. Serious infection or reaction may occur if medical attention is not received at once.

FRONT TRACTOR ATTACHMENT

1. Clamp front attachment mounting arm to the bottom side of the undercarriage frame.

NOTE: The location of the mounting arm along the undercarriage will vary depending on the size and model tractor used to power the conveyor. The mounting arm should be located ahead of front tractor tires to avoid interference with the tractor tires when turning.

Use clamp plates and 5/8" x 9" long hex head grade 5 bolts with lock-washers and nuts to secure the mounting arm to the underside of undercarriage frame.

2. Fasten the turnbuckle attach arm to the mounting arm using 1" diameter x 5" long washer head pin with flat washer and 1/4" lynch pin.
3. Attach the turnbuckle attach arm to the tractor mount. A 1" diameter x 5" long washer head pin, flat washer and 1/4" lynch pin is furnished for this purpose.

NOTE: The tractor mount is not furnished as standard equipment with the conveyor. Due to the various sizes and models of tractors used to power the conveyor, the conveyor operator must provide a mount. A number of tractor mounts are available from Hutchinson if the tractor size and model can be furnished. See Page 9.

4. Adjust the turnbuckle attach arm so the conveyor is parallel with the tractor body.
5. Check all undercarriage fasteners to be sure they are tight.

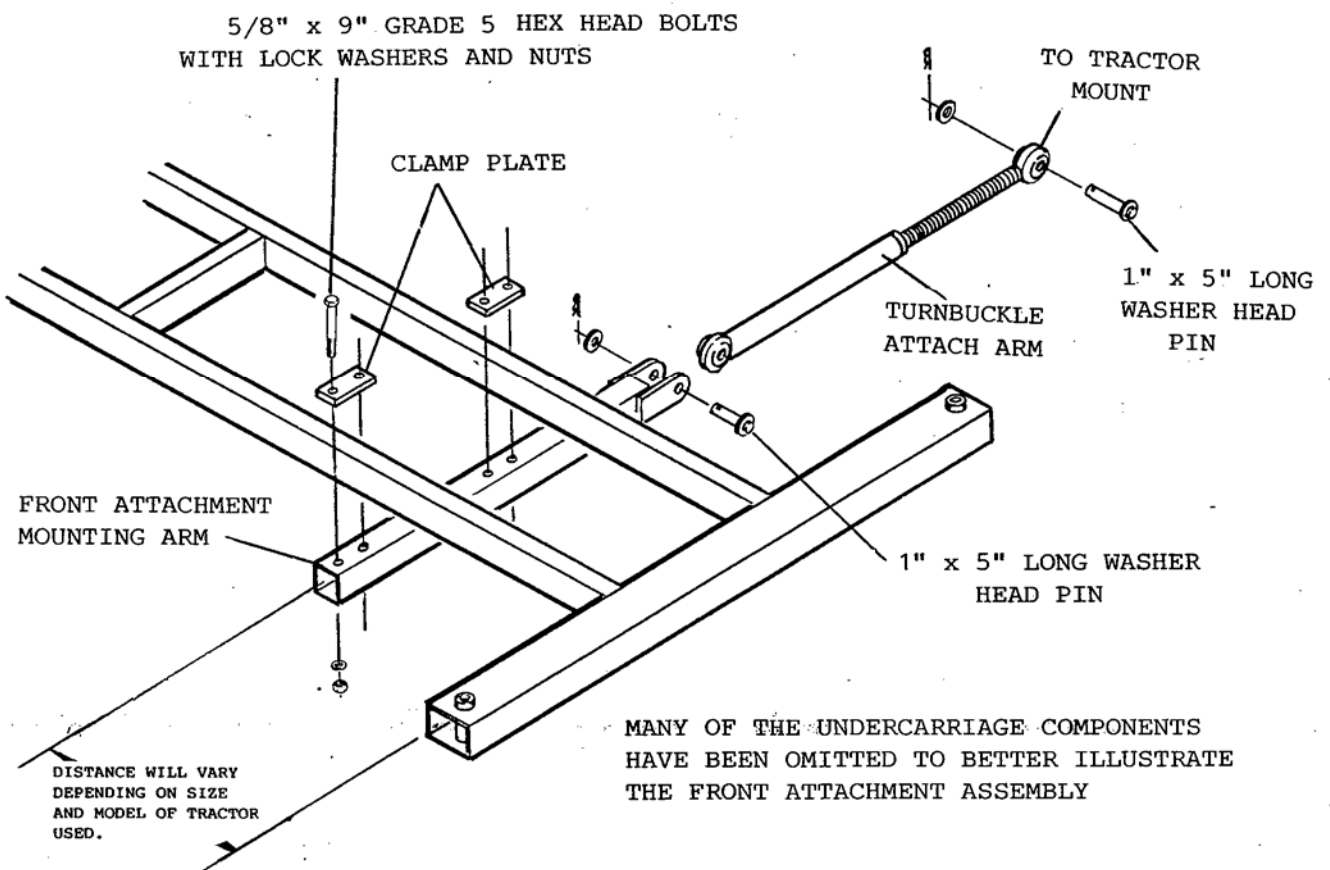

INPUT DRIVE LINE TO GEARBOX

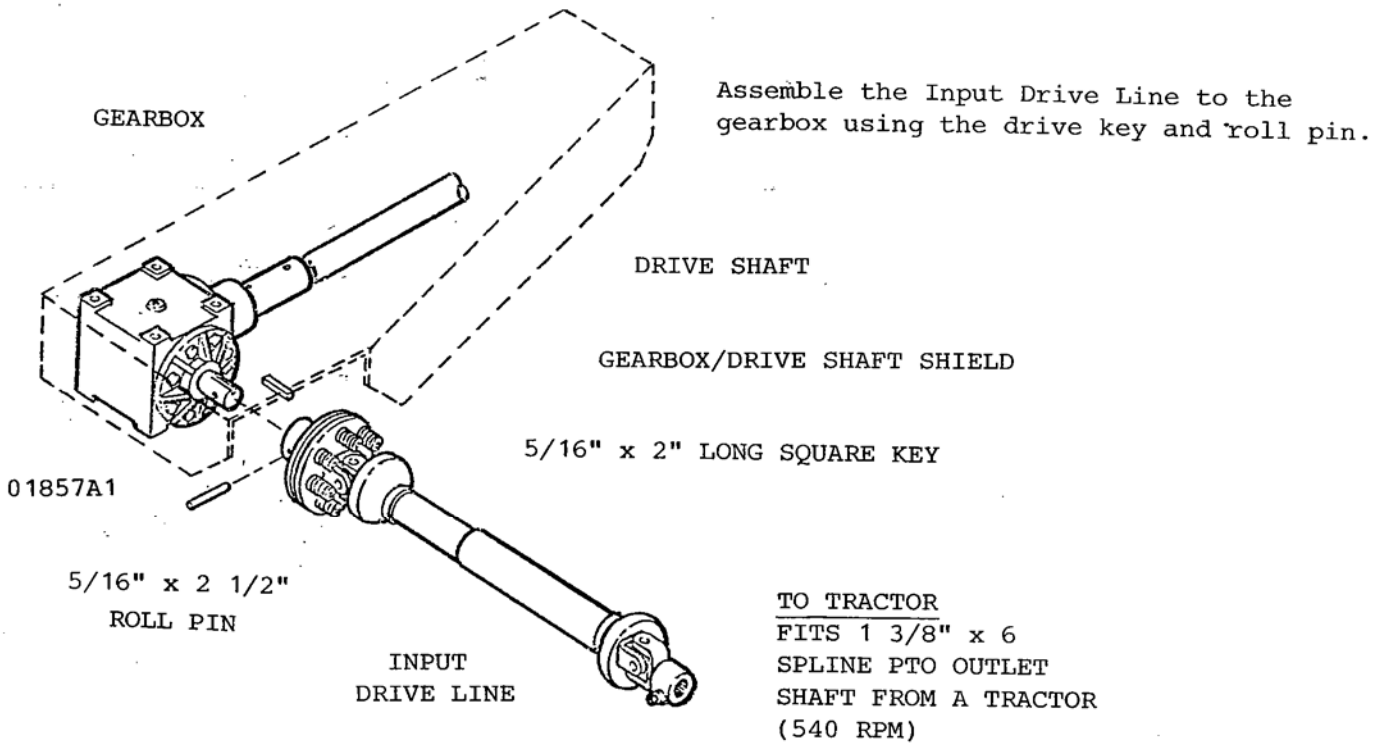

 The gearbox/drive shaft shield must be in place covering the drive shaft and Input Drive Line/Gearbox connection whenever the conveyor is in operation.

CATEGORY #3 THREE-POINT HITCH KIT (OPTIONAL)

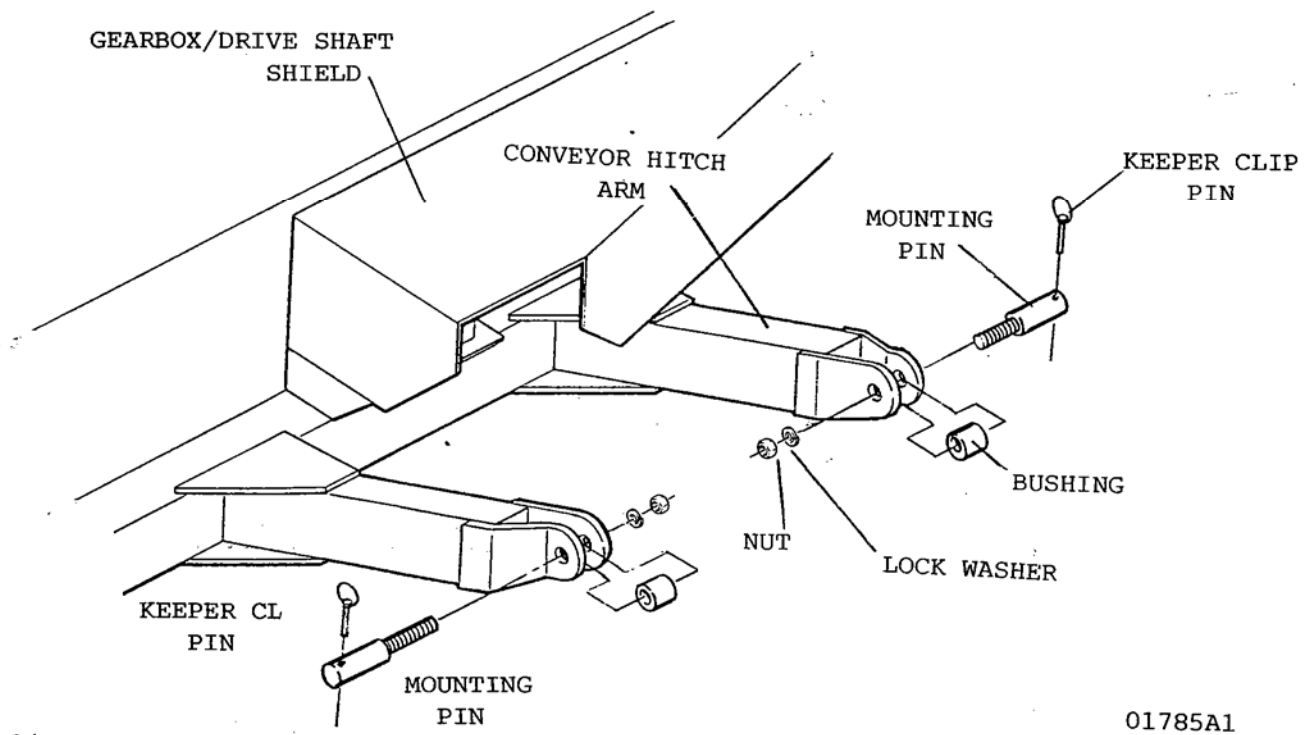

OPTIONAL INTAKE HOPPER

WARNING: Do not install hopper when tractor is running. Turn off tractor and lockout power.

1. Slide optional hopper panel and screen inside of main hopper end plates.
2. The retaining clip on the bottom of optional hopper panel must slide over the main hopper shovel angle. See Fig. A.
3. The optional hopper screen must fit over the main hopper screen and support tube. See Fig. B.
4. Secure hopper in place by using five 5/16" x 1" long hex head bolts, lock washers and nuts.

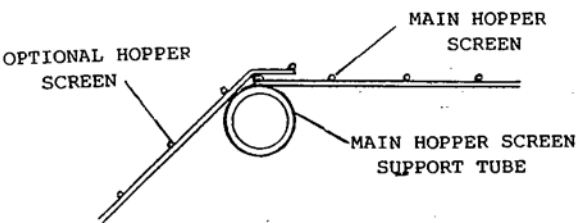
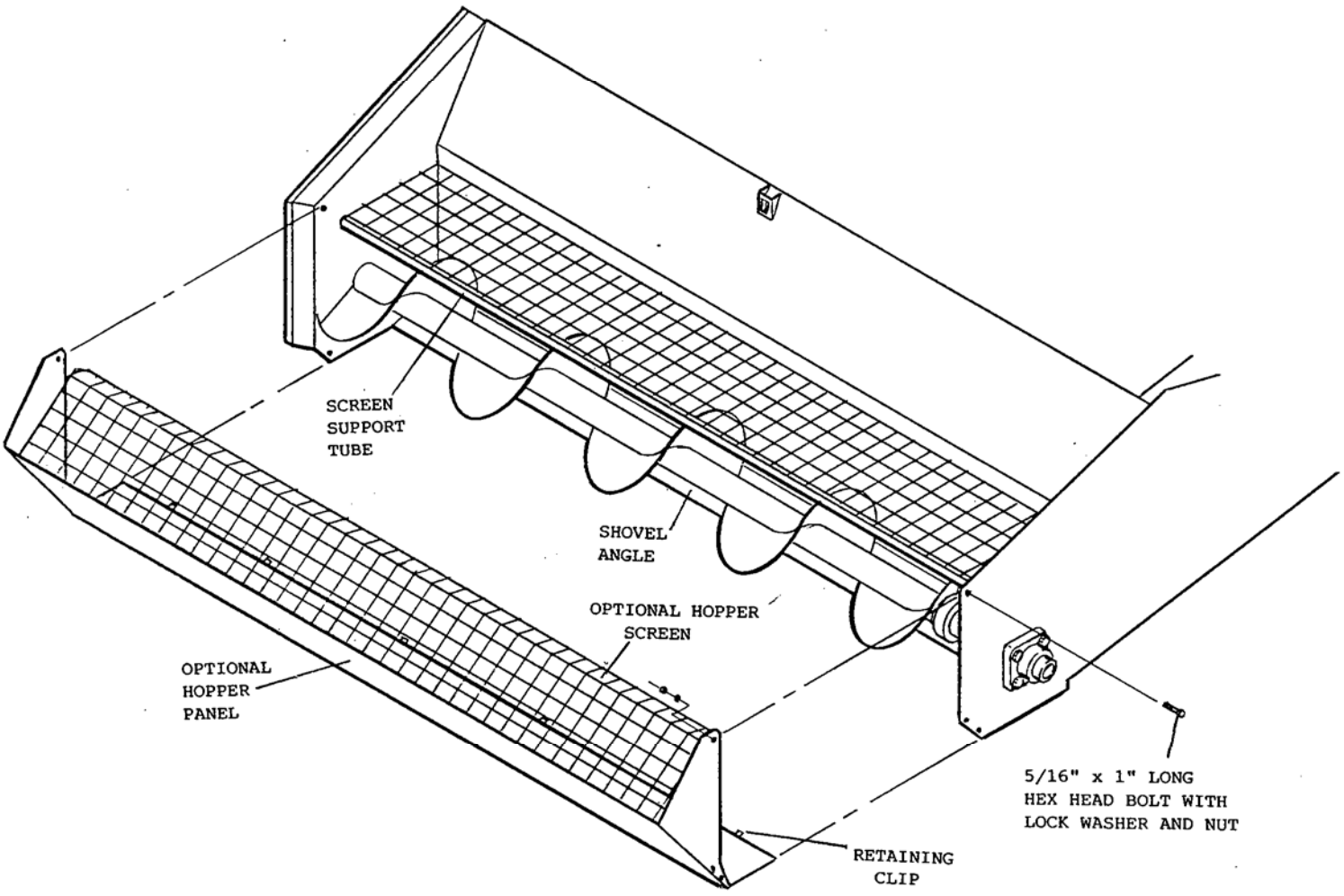

FIG. B

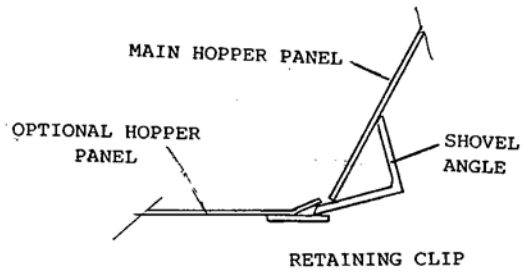
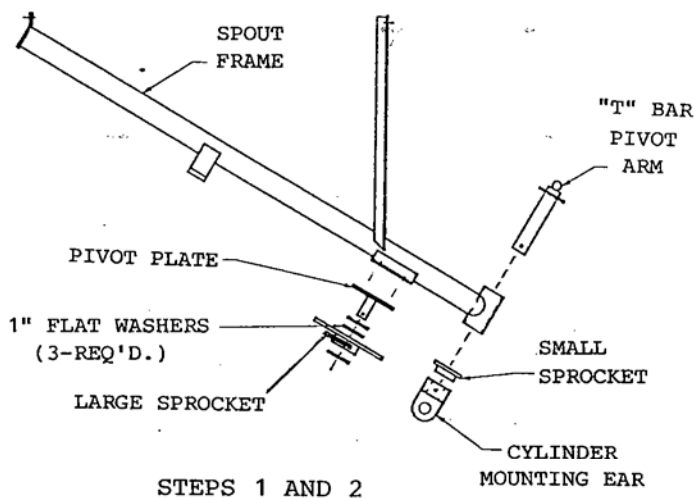

FIG. A

OPTIONAL ADJUSTABLE SWIVEL SPOUT



1. Insert T-Bar into frame and attach small sprocket T-Bar with 1/4" key. Slip cylinder mounting ear onto shaft and fasten with 5/16" bolt and lock nut.
2. Bolt pivot plate to frame with four carriage bolts, lockwashers and nuts. Slip two 1" flat washers onto the pivot plate pin along with the large sprocket, another 1" flat washer and hold them in place with a cotter pin.
3. Bolt mounting angle to spout frame with 3/8" x 1" bolts, lockwashers and nuts.

4. Position and bolt spout frame to the head. (The mounting angle must be welded to the head.) Use 3/8" x 1 1/4" bolts.
5. Bolt spout to head with 5/16" x 1" bolts, lockwashers and nuts.
6. Slip spout onto pivot arm and hold in place with collars, 5/16" bolts and lock nuts.
7. Pin cylinders to spout as shown. The hose port restrictor must be installed in the base of the cylinder.
8. Extend rear cylinder halfway through its stroke. Position spout midway (in line with the head). Mount chain to sprockets.

9. Bolt the spout extension to the 1st spout with two 3/8" x 3/4" bolts, two 3/8" x 3/4" carriage bolts, lockwashers and nuts.

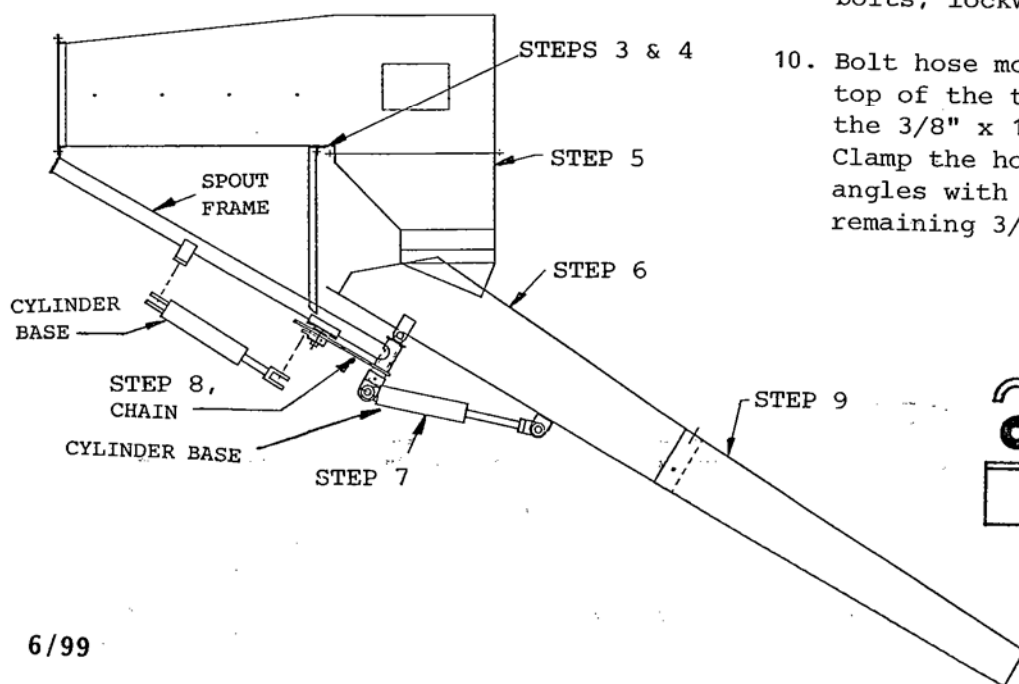

10. Bolt hose mounting angle to the top of the trunk flanges with the 3/8" x 1 1/4" bolts provided. Clamp the hoses to the mounting angles with the clamps and the remaining 3/8" x 1 1/4" bolts.

AGI HUTCHINSON MAYRATH

MANUFACTURED BY
HUTCHINSON | MAYRATH

P.O. Box 629, 514 W. Crawford Street **TF 800.523.6993**
Clay Center, Kansas **P 785.632.2161**
USA 67432 **F 785.632.5964**

hutchinson-mayrath.com