

12" COMMERCIAL GRAIN PUMP® LOOP CONVEYING SYSTEM

OWNER'S & OPERATOR'S MANUAL

Effective September 29, 2015

Publication No. 1039459

IMPORTANT! The reducer gear box is shipped Without Oil.
Oil must be added before conveyor operation.
Refer to the Lubrication Section in this manual.



Hutchinson/Mayrath

A Division of **GLOBAL** Industries Inc.

Hutchinson/Mayrath • P.O. Box 629 • Clay Center, KS. 67432
Ph. 785-632-2161 • Fx. 785-632-5964 • Toll Free 800-523-6993
www.hutchinson-mayrath.com



Hutchinson/Mayrath

A Division of **GLOBAL** Industries, Inc.

POLICIES AND PROCEDURES

- Prices:** Prices in effect at time of shipment will apply. Prices are subject to change without notice. All prices are F.O.B. Clay Center, Kansas. Orders shipped from locations other than Clay Center, Kansas will be subject to additional charges, such as back freight and/or additional freight.
- Service Charge:** A service charge will be assessed for all past due balances as permitted by state law not to exceed 1-1/2% per month.
- Minimum Order:** Processing and handling costs necessitate a minimum charge of \$15.00 net on all orders.
- Back Orders:** Back orders will be shipped as they become available. Contact Hutchinson/Mayrath Customer Service for alternative shipping options or if cancellation is desired.
- Damaged Goods:** It is the consignee's responsibility to check all shipments thoroughly upon receipt of goods. If any damage is discovered, it must be noted on the freight bill of lading before signing. The consignee must make necessary claims against the respective freight line. All damage claims must be submitted within 30 days of delivery receipt.
- Shortages:** All shortages must be noted at time of delivery. Shortages must be noted on the freight bill of lading before signing. Hutchinson/Mayrath must be advised of all concealed shortages upon discovery. Once notified of concealed shortages Hutchinson/Mayrath will advise corrective action to be taken.
- Return of Goods:** All returns must be approved by Hutchinson/Mayrath prior to shipment. All return requests will be issued a return authorization number. **NO RETURNS WILL BE ACCEPTED WITHOUT A RETURN AUTHORIZATION NUMBER AND PRIOR AUTHORIZATION FROM THE FACTORY.** All returns must be shipped prepaid. A 15% restocking charge will be applied to all returned merchandise. Custom Products may not be returned for credit. Only current products in new and salable condition may be returned. No safety devices may be returned for credit.
- Modifications:** It is the policy of Hutchinson/Mayrath to improve its product whenever possible and practical to do so. We reserve the right to make changes, improvements and modifications at any time without incurring the obligation to make such changes, improvements and modifications on any equipment sold previously.
- Limited Warranty:**
- (a) For a period of (1) year after receipt of goods by the original consumer buyer, Hutchinson/Mayrath will supply free of charge replacement parts for parts that prove defective in workmanship or material. Defective parts must be returned freight prepaid to a specified Hutchinson/Mayrath location. Only Hutchinson/Mayrath original repair parts may be used for warranty repairs.
 - (b) This limited warranty does not extend to parts designed to wear in normal operation and be replaced periodically; or to damage caused by negligence, accident, abuse or improper installation or operation.
 - (c) **GOODS NOT MANUFACTURED BY HUTCHINSON/MAYRATH CARRY ONLY THE MANUFACTURER'S WARRANTY.**
 - (d) **THIS UNDERTAKING IS IN LIEU OF ALL OTHER WARRANTIES, EXPRESSED OR IMPLIED, INCLUDING MERCHANTABILITY AND FITNESS FOR A PARTICULAR PURPOSE.**
- FAILURE TO FOLLOW THE INSTRUCTIONS CONTAINED IN THE OWNER'S & OPERATOR'S MANUALS AND THE ITEMS LISTED BELOW WILL RESULT IN THE VOIDING OF THIS LIMITED WARRANTY.**
- (1) Improper assembly, including failure to properly install all safety equipment.
 - (2) Improper installation.
 - (3) Unauthorized alternations of goods.
 - (4) Goods operated when obviously in need of repair.
 - (5) Use of unauthorized repair parts.
 - (6) Irresponsible operation.
 - (7) Used to handle materials other than free flowing, nonabrasive and dry materials, as intended.
 - (8) Damaged through abusive use or accident.
- Limitation of Liability:** BUYER AGREES THAT IN NO EVENT SHALL HUTCHINSON/MAYRATH HAVE LIABILITY FOR DIRECT DAMAGES THE EXCESS OF THE CONTRACT PRICE OF THE GOODS IN RESPECT OF WHICH CLAIM IS MADE. BUYER FURTHER AGREES THAT IN NO EVENT SHALL HUTCHINSON/MAYRATH ON ANY CLAIM OF ANY KIND HAVE LIABILITY FOR LOSS OF USE, LOSS OF PROFITS, OR FOR ANY INDIRECT, INCIDENTAL OR CONSEQUENTIAL DAMAGES.

TABLE OF CONTENTS

POLICIES AND PROCEDURES	(Inside Front Cover)
TABLE OF CONTENTS	1
SAFETY	2 - 4
General Safety Statement	2
Safety Alert Symbol	2
Safety Decals	4
GENERAL INFORMATION	5 - 8
Operator Qualifications	5
Sign-Off Sheet	5
Machine Inspection	6
Start-Up & Break-In Information	6
Designated Work Area	6
Conveyor Horsepower Information	7
How to Calculate Total Horsepower	7
Electric Motor Drive Information	8
Full Load Operation Information	8
OPERATING PROCEDURES	9
Conveyor Operating Procedures	9
Shutdown/Lockout	9
LUBRICATION & MAINTENANCE	10 - 14
General Maintenance Information	10
Conveyor Chain	10
Bearings, Inspection Corner, Drive & Standard Corners, R&P Dump Hopper	11
Drive Belts	12
Drive and Corner Sprockets	12
Auto Take-Up Corner	12
Gear Reducer	13
Rack & Pinion, Commercial and Standard	14
Trouble Shooting	14
ASSEMBLY INSTRUCTIONS	15 - 44
Installation and Layout	15
Layout Considerations	15-16
Installation Information	15
System Support Information and Grain Flow & Drive Corner Location	17
Tube, Corner and Discharge w/ Gate Assembly	18
Bin Well Assembly Commercial & Standard	19-24
Pipe Control Kit Assembly,	25-29
Rack and Pinion, Standard and Commercial	30-31
Inlet Dump Hopper	32
Manual Take-Up Inspection Corner	33
Auto Take-Up Inspection Corner	34
Drive Corner	35
Conveyor Chain and Paddle, Single Strand and Double Strand	36-37
Discharge w/ Cable Ground Control Gates	38-39
Discharge w/ Chain Ground Control Gates	40-43
Inlet Hoppers & Inspection Ports (Band-On)	44
Chain Maintenance Access Assembly	44
PARTS LIST TABLE OF CONTENT	P-1
PARTS LIST	P-2 - P-34

SAFETY

GENERAL SAFETY STATEMENT

This manual was written with the safety of the operator and others who work with the equipment as our prime concern. The instructions presented will help the reader learn **SAFE** day to day work practices. We want you as our partner in safety.

It is your responsibility as an owner, operator or supervisor to know what specific safety requirements and precautions exist and to make these known to all other personnel working with the equipment or in the area, so that they too may safely perform their duties and avoid any potentially hazardous situations.

We suggest the implementation of a Safety Program for all personnel that includes, but is not limited to, the proper use of PPE (personal protective equipment), Fall Protection Systems and Lock Out-Tag Out procedures.

Please remember safety equipment provides important protection for persons around a grain handling system that is in operation. Be sure **ALL** safety shields and protection devices are installed and properly maintained. If any shields or guards are damaged or missing, contact your dealer to obtain the correct items.

Avoid any alterations of the equipment. Such alterations may create a dangerous situation where serious injury or death may occur.

SAFETY ALERT SYMBOL

The safety symbol shown is used throughout this manual to alert you to information about unsafe actions or situations, and will be followed by the word DANGER, WARNING, or CAUTION.

DANGER - Indicates immediate hazards that may result in severe injury or death. **WARNING** - Indicates unsafe actions or situations that may cause severe injury, death and/or major equipment or property damage. **CAUTION** - Indicates unsafe actions or situations that may cause injury, and/or minor property damage.

Watch this symbol - it points out important safety precautions. It means - **ATTENTION! Become alert! Your safety and the safety of others is involved!** Read the message that follows the symbol when a warning is given, be alert to the possibility of personal injury or death.



Follow Safety Instructions

Carefully read all safety messages in this manual and safety signs on your machine. Check to ensure all Safety Decals are present and in good condition.

If a decal cannot easily be read for any reason, or has been painted over, replace the decal immediately. Safety decals are offered free of charge, and can be ordered through your Hutchinson/Mayrath dealer or directly from the factory.

Learn how to operate the machine and how to use controls properly.

Keep your machinery in proper working condition. Understand service procedures before doing work. Never lubricate, service or adjust machine while it is in operation.

Keep work area clean, dry and free from of all debris and tools which may cause accidental tripping or falling.



Read and Understand Manual

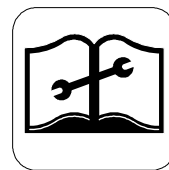

Understand Service Procedures



Keep Work Area Clean

Prepare for Emergencies

Keep emergency numbers for doctors, ambulance service, hospital and fire department near your telephone.

Keep a first-aid kit and fire extinguisher handy.

Be prepared if a fire starts

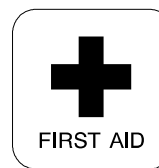

First Aid Equipment



Fire Extinguisher

Wear Proper PPE (Personal Protective Equipment)

Some materials can create flying debris when they are filed, cut or drilled. Safety glasses should be worn at all times to protect your eyes from such debris.

Hearing protection should be worn when operating power tools or other power equipment that could be harmful to your hearing.

Gloves should be worn to protect your hands from sharp metal and plastic edges, as well as providing protection from the handling of heavy objects.

Wear steel toe boots to protect your feet from falling debris.

Wear a hard hat to help protect your head from falling objects as well as from accidental bumping.

Use caution when working at elevations greater than four (4) feet (1.22 m) above the ground.

Use the appropriate fall protection equipment as set forth by OSHA guidelines and regulations.

A respirator may be needed to prevent breathing potentially toxic fumes and dust, especially when working within a grain bin or storage structure.

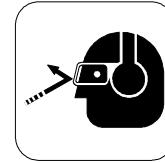

Eye & Hearing Protection



Gloves



Steel Toe Boots

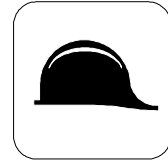

Hard Hat



Fall Protection

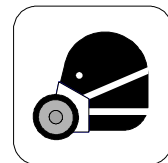

Respirator

Operate Electric Motor(s) Properly

Do not operate electric motor equipped units until motor(s) are properly grounded.

Know how to "Shutdown and Lockout" the power source. Shutdown and lockout power source before performing any service, maintenance or adjustments to the unit.

Disconnect power on electrical driven units before resetting motor overloads.

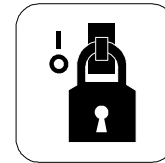

Lockout / Tagout



Electric Shock Hazard

Stay Clear of Moving Parts

Keep all shields, covers and safety devices in place at all times.

Entanglement in moving chains, rotating impeller arms and sprockets will cause serious injury or death.

Wear close fitted clothing. Keep hands, feet and clothing away from moving parts.

Shutdown and lockout power source before making adjustments, cleaning or maintaining the equipment.

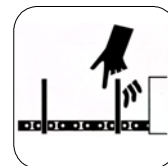

Entanglement Hazards



SAFETY

GRAIN BIN SAFETY

The Commercial Loop System is generally designed to move grain into or from grain bins or other storage structures. **Be aware of the dangers inherent in grain bins.**

Consult the grain bin manufacturer's manual for information on the proper loading and unloading of the bins, structural stress analysis, adequate venting and important safety information.



WARNING! Do Not enter the bin if the grain has “Bridged” or has not flowed normally out of the bin, See Example’s 1 & 2. The grain may suddenly break loose and bury resulting in suffocation.



Do Not enter the bin unless all power driven equipment has been shut down and locked out. Never enter the bin unless monitored by another person.

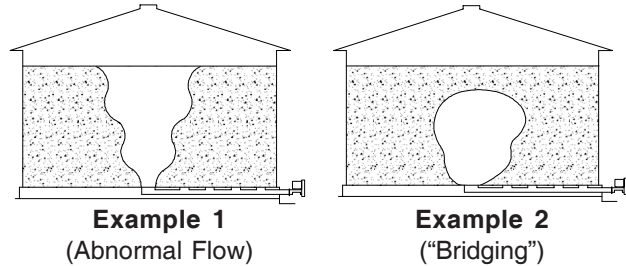

SAFETY DECALS

Check to ensure all Safety Decals are present and in good condition. If a decal cannot easily be read for any reason, or has been painted over, replace the decal immediately. Safety decals are offered free of charge, and can be ordered through your Hutchinson/Mayrath dealer or directly from the factory.

Refer to the Parts List Section for decal Part No's. and location of decals on components.

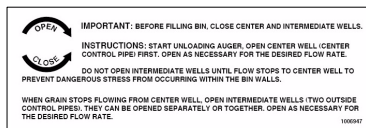

OPERATOR QUALIFICATIONS



WARNING

Anyone who will operate or work around this machine shall first read this manual! This manual must be delivered with the equipment to its owner. Failure to read this manual and its safety instructions is a misuse of the equipment.

Operation of this conveyor system shall be limited to competent and experienced persons. In addition, anyone who will operate or work around a conveyor must use good common sense. In order to be qualified, he must also know and meet all other requirements, such as:

1. Some regulations specify that no one under the age of 16 may operate power machinery. This includes this conveyor. It is your responsibility to know what these regulations are in your area or situation.
2. Current OSHA regulations state in part: "At the time of initial assignment and at least annually thereafter, the employer shall instruct every employee in safe operation and servicing of all equipment with which the employee is, or will be involved." *

3. Unqualified persons are to stay out of the work area. See Page 6.
4. A person who has not read and understood all operating and safety instructions is not qualified to operate the machine.
5. Persons operating, servicing or repairing equipment that requires above ground work shall be properly secured with the use of "fall protection" equipment as set forth by OSHA guidelines and regulations.

*Federal Occupational Safety & Health Standards for Agriculture Subpart D, Section 1928.57 (a) (6).

SIGN OFF SHEET

As a requirement of OSHA, it is necessary for the employer to train the employee in the safe operation and safety procedures with this conveyor. We include this sign off sheet for your convenience and personal record keeping.

<u>Training Sign-Off Sheet</u>		
Date	Employer Signature	Employee Signature

SERIAL NUMBER

To ensure efficient and prompt service, please furnish us with the model and serial number of your conveyor in all correspondence or other contact. The serial plate is located on each of the drive corners.

GENERAL INFORMATION

MACHINE INSPECTION

After completion of assembly and before each use, inspection of the machine is mandatory. This inspection should include, but not be limited to:

1. Inspect the conveyor for loose bolts, missing chain parts, missing or damaged paddles and the overall chain condition.
2. Check chain tension.
3. Check the condition and tension of drive belts and adjust as necessary.
4. Inspect sheaves for alignment and see that they are securely fastened.
5. Check oil level in drive reducer.
6. Check all safety signs and replace any that are worn, missing or illegible. The safety signs are listed in the front of this manual. Safety signs may be obtained free of charge from your dealer or ordered from the factory.
7. Check that all safety devices, guards and shields are installed and that all inspection doors are latched closed.
8. Check auto take-up corner, if so equipped. See that the sprocket carriage is free to move up and down. Lubricate, as necessary.

Obtain any needed replacement parts from your dealer and install before using the machine.

START-UP and BREAK-IN INFORMATION



WARNING! During initial start-up and break-in period, the operator shall be aware of any unusual vibrations or noises that would indicate a need for service or repair.



Keep all safety shields and devices in place. Keep hands, feet, and clothing away from moving parts.



The operator should have a full view of the auger work area and check that all personnel are free from designated work areas before adding power.

It is essential to inspect your conveyor and drive components before adding power and to know how to shut down in an emergency. During the operation of your conveyor, one person shall be in a position to monitor the operation.

During the initial start-up and break-in period, the operator should watch for any unusual vibrations or noises.

START-UP and BREAK-IN INFORMATION (con't.)

Any conveyor, when it is new or after it sits idle for a season, should go through a "break-in" period. It should be run at partial capacity at full speed until the inside of the housing becomes polished, before attempting full capacity. A failure will most likely occur when it is run at full capacity before it has a chance to "shine up".

If at all possible, do not start or stop the Grain Pump® Conveyor under load, especially before the housing becomes well polished, as this may cause the unit to stall. If so equipped, inspect and lubricate the automatic take-up corner. Be sure that the sprocket carriage is free to move up and down.

DESIGNATED WORK AREA

The area around the conveyor and inside the grain storage units is considered the work area. Use the following to ensure a safe working environment.



WARNING! Under no circumstances should persons not involved in the operation be allowed to trespass into the work area.

It shall be the duty of all operators to see that children and/or other persons stay out of the work area! Trespass into the work area by anyone not involved in the actual operation, or trespass into a hazard area by anyone shall result in an immediate shutdown by the operator.



It shall be the responsibility of all operators to see that the work area has secure footing, is clean and free of all debris and tools which might cause accidental tripping and/or falling. It shall also be their responsibility to keep the work area clean and orderly during the operation.



Use caution when working in areas above the ground. Persons operating, servicing or repairing equipment that requires above ground work shall be properly secured with the use of "fall protection" equipment as set forth by OSHA guidelines and regulations.



Metal buildings, scaffolding and other types of work surfaces can become slippery, especially when surfaces are wet and/or oily. This can create hazardous working conditions. Use caution when working, climbing or walking on these surfaces.

CONVEYOR HORSEPOWER (KW) INFORMATION

The height and length of a loop system are limited by the combined power required to move grain those distances. The vertical component requires greater power per foot (*meter*), so taller units will be more limited in horizontal length. System lengths of several hundred feet are common. However, relatively small systems to accomplish more specific tasks are often built.

Loop units are provided with Dodge gear reducer drives to be driven by one or two electric motors. There are maximum power limits for each drive, but when greater power than can be provided by one drive is needed, a second drive of equal power can often be added. Drives are always located at upper corners. A single drive must always be located at the top corner after the last discharge.

Overfeeding a grain pump loop may cause plugging. We recommend the loading rate be monitored by an amp meter on the electric motor drive(s). The Grain Pump® will operate more smoothly, move more grain and last longer if loaded 80% of fill, instead of an uncontrolled approach to 100% of fill. "Soft Start" motors are always recommended to protect a conveyor from high torque shocks against a unit that may have inadvertently been stopped under load or plugged.

HOW TO CALCULATE TOTAL HORSEPOWER (KW)

NOTE: The power recommendations are for conveying reasonably dry grain at approximately 56 lbs. per bushel (720 kg per cu. meter). Adjust the power requirements up or down for material of a different density.

1. Determine the vertical height of the system, usually the peak height of the tallest bin plus 3' (1 m). **Multiply the vertical height by the vertical HP factor of .75 (1.8 kw) to determine the vertical power requirement.**
2. Add the total upper and lower horizontal length of conveyor that will contain material during operation. If you plan to recirculate the grain at full capacity from one storage structure to another, it may add length to the power calculation. **Multiply the total horizontal length by the horizontal HP factor .18 (.44 kw) to determine the horizontal power requirement.**
3. Add the vertical and horizontal power together to find the total system power required.

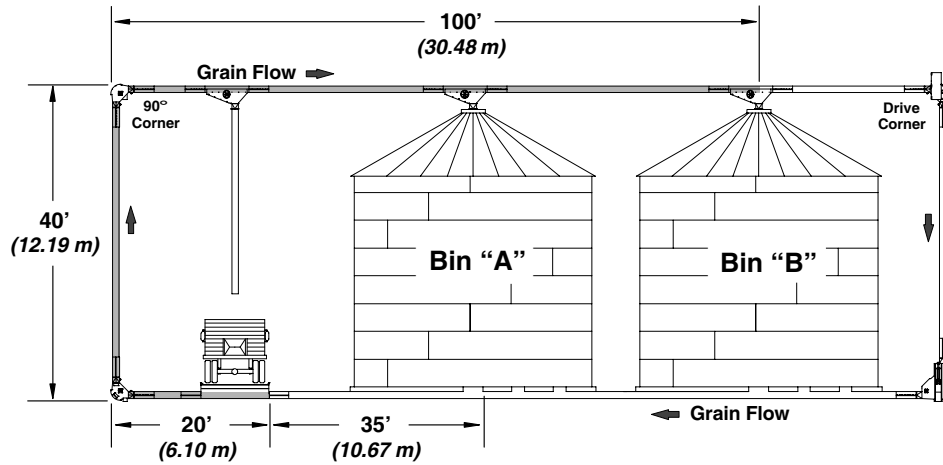

Pump Diameter	Vertical (per ft./m)	Horizontal (per ft./m)
12"	HP (kw) factor = .75 (1.8)	HP (kw) factor = .18 (.44)

In this example, there is 40 ft. (12.19 m) of vertical conveyor and 120 ft. (36.58 m) of horizontal conveyor that will contain grain.

Vertical HP Requirement 40' (12.19 m) x .75 (1.8) HP (kw) factor = 30 (22.3 kw)

Horizontal HP Requirement 120' (36.58 m) x .18 (.44) HP (kw) factor = 21.6 (16.1 kw)

Total HP (kw) - Vertical + Horizontal = 51.6 (38.4 kw)

Electric Motor size required = 60 HP (45 kw)

If there are plans to transfer grain from Bin A to Bin B, an additional 35 ft. of horizontal length must be added to the calculation.

Horizontal HP (kw) requirement, 35' (10.67 m) x .18 (.44) HP (kw) factor = 6.3 (4.6 kw) added to previous 51.6 (38.4 kw)

Total HP (kw) - Vertical + Horizontal = 57.9 (43.1 kw)

Electric Motor Size Required = 60 HP

ELECTRIC MOTOR DRIVE INFORMATION

 **WARNING! A main power disconnect switch that can be locked in only the "OFF" position shall be provided. This shall be locked whenever work is being done on the conveyor.**

The reset and starting controls must be located so that the operator has full view of the entire operation.

 **Do Not enter the grain bin unless all power driven equipment has been shut down and locked out.**

Make certain electric motor is grounded.

 **Disconnect power before resetting motor overloads.**

Shut off power and lockout whenever cleaning or servicing the conveyor.

Always use a motor with required HP (*kw*) as calculated on previous page (Page 7). Use a 60 hz motor that operates at 1750 rpm (50 hz @ 1460 rpm).

Electrical motor and controls shall be installed by a qualified electrician and must meet the standards set by the National Electrical Code and all local and state codes.

A magnetic starter should be used to protect your motor when starting and stopping. It should stop the motor in case of power interruption, conductor fault, low voltage, circuit interruption or motor overload. Then the motor must be restarted manual.

Some motors have built-in thermal overload protection. If this type motor is used, use only those with a manual reset.

Install with an ampmeter on motor or motors, so that the load can always be monitored to prevent overloading.

A main power disconnect switch that can be locked only in the "Off" position shall be provided. This shall be locked whenever work is being done to the conveyor.

FULL LOAD OPERATION INFORMATION

Operation of the Grain Pump® Conveyor will generally include moving grain into or out of grain storage structures.

Grain will enter the conveyor through a dump hopper or through bin wells in grain bins. There are flow control devices included with these components that should be used to control grain flow rates into the conveyor.

FULL LOAD OPERATION INFORMATION (con't.)

It is possible to use more than one inlet component at the same time, such as when blending is desired or simply to increase the flow rate into the conveyor.

Grain is discharged from the conveyor through outlets with movable gates for opening and closing the outlets. Optional ground controls are available for operating the gates. All gates should be closed except the one at the selected discharge point.

A sweep auger may be placed in the bin after all the grain has been removed that will gravity-flow through the center well. The grain remaining should appear as in Fig. 3. Shut down and lock out the Grain Pump® before installing the sweep auger.

If intermediate bin wells are being used, they should be opened after grain has stopped flowing into the center well and before the sweep auger is placed in the bin. See Fig. 4. Shut down and lock out the Grain Pump® before installing the sweep auger.

 **WARNING! Do Not enter the bin if the grain has "Bridged" or has not flowed normally out of the bin, See Fig's. 1 & 2. The grain may suddenly break loose and bury resulting in suffocation.**

 **Do Not enter the bin unless all power driven equipment has been shut down and locked out.**

Never enter the bin unless monitored by another person.

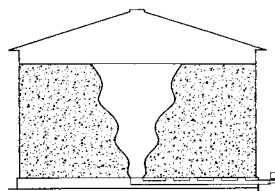

Fig. 1
(Abnormal Flow)

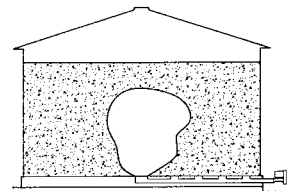

Fig. 2
("Bridging")

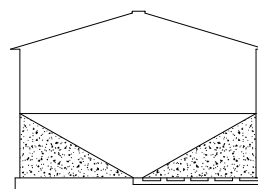

Fig. 3
Grain Flow Through Center Bin Well

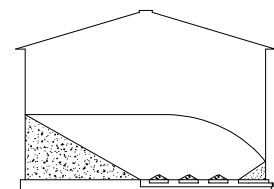

Fig. 4
Grain Flow Through Intermediate Wells

OPERATING PROCEDURES



WARNING! Make certain everyone is clear before operating the equipment.

The operator shall be aware of any unusual vibrations or noises that would indicate the need for service or repair.

Keep all safety shields in place.

Keep hands, feet and clothing away from moving parts.



The operator shall have a full view of the entire work area and check that all personnel are clear of the designated work area before adding power.

If the operator must leave the work area, or whenever servicing or adjusting, the conveyor must be stopped and the power source turned off and locked out.



Precaution should be made to prevent anyone from operating the conveyor when the operator is absent from the work area.

The reset and starting controls must be located so that the operator has full view of the entire operation.

Do Not enter the grain bin unless all power driven equipment has been shut down and locked out.

Make certain electric motor is grounded.



Disconnect power before resetting motor overloads.

Shut off power and lockout whenever cleaning or servicing the conveyor.

Never enter the bin when the sweep auger is in operation. Never attempt to control the operation of the sweep auger by pushing on an operating sweep auger with shovels, brooms or other devices.



Do Not attempt to restrain the movement of the sweep auger by attaching ropes, bars or other devices to be held by an operator.

1. Start the conveyor for operation. Open the conveyor outlet gate for the desired discharge point (all gates should be closed except the one at the selected discharge point).

2. If moving grain from bins or storage structures, gradually open the gate in the center well until desired flow is established. **Do Not** overload the conveyor.

If intermediate wells are used, they should be opened **after** grain has stopped flowing into the center well.

When the desired amount of grain has been moved or unloaded, close all bin wells and allow the conveyor to clean itself out. **Shut down and lock out power source.**

3. If moving grain through a dump hopper, begin unloading grain from dump vehicle in small increments and gradually build up to desired flow. **Do Not** overload conveyor.

After grain flow from dump vehicle has stopped, allow the conveyor to clean itself out and close outlet gate.

Shut down and lock out power source.

EMERGENCY SHUTDOWN

Should the machine need to be immediately shut down under full load, **disconnect** and **lockout** the power source. Clear as much grain from the hopper and conveyor as possible. Use the release door provided in the standard corner to drain the vertical tube after the dump hopper.

Never attempt to restart when full. Starting the unit under full load may result in damage. Such damage is considered abuse of the equipment and will not be warranted.

NORMAL SHUTDOWN

Close flow controls in bin wells and allow the conveyor to empty before stopping the unit.

Before the operator leaves the work area, the power source shall be locked out.

INTERMITTENT SHUTDOWN

When a conveyor is stopped and started under full load, it may result in damage to the conveyor. Therefore, if intermittent operation is to be carried out, it is advisable to reduce the load level.

If a conveyor is kept from absolute filling, it will make start-up easier and will convey grain more efficiently.

LOCKOUT

The power source shall have a main disconnect box that can be locked only in the “Off” position. This is what “shutdown and lockout” refers to, shut off the main power source and lock handle or breaker switch in the “Off” position.

GENERAL MAINTENANCE INFORMATION

WARNING! A main power disconnect switch that can be locked in only the “OFF” position shall be provided. This shall be locked whenever work is being done on the conveyor.



Keep all safety shields and devices in place.

Never clean, adjust or lubricate a machine that is in operation.



Disconnect power before resetting motor overloads.

Shut off power and lockout whenever cleaning or servicing the conveyor.

Keep hands, feet and clothing away from moving parts.

For economical and efficient operation of your Grain Pump® maintain regular and correct lubrication. Neglect leads to reduced efficiency, excessive wear, and needless down time. Regular inspections should be established in order to ensure that the equipment is in good operating condition at all times. Use the “Machine Inspection” list on Page 6 for guidelines.

The following information will detail the parts that require lubrication and the various conditions that determine the frequency span.

CONVEYOR CHAIN

It is important not to overtighten the conveyor chain. However, if the chain is not sufficiently tight, it will slip at the drive sprocket as capacity is increased. Should this occur, shut off grain flow to the unit and allow conveyor to clean itself out. **Shutdown and lockout the power source (See Page 9).**

To check conveyor chain tension, open the inspection door, grasp one of the paddles and attempt to rotate it up toward the chain. Proper chain tension should allow only minimum rotation of the paddle (See Fig. 5).

Inspect the conveyor chain for loose bolts, missing chain parts, missing or damaged chain paddles and the overall chain condition.

IMPORTANT SERVICE - MAINTENANCE NOTICE:

The life of the conveyor chain will be shortened when the chain is allowed to sit in water or is operated in acidic conditions, so avoid these situations as much as possible.

To extend chain life, spray a light coat of vegetable oil on the chain after each season’s use.

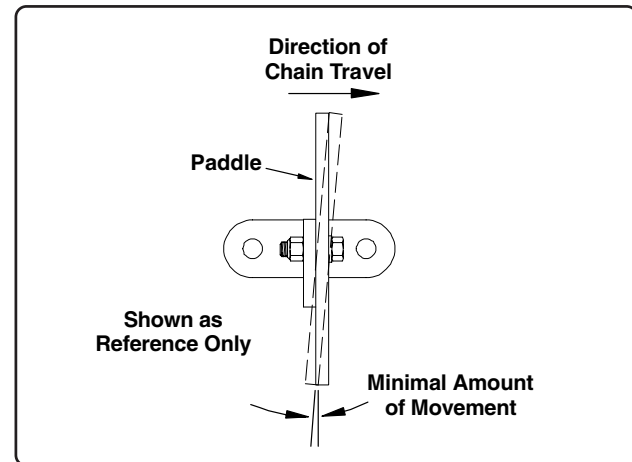
**Fig. 5**

Another indicator of proper chain tension is whether the traction wheel is turning while the loop system is running. When the chain gets slack in it, it loses contact with the smooth surface of the traction wheel so the wheel and shaft do not turn.

Also, the wheel and shaft may turn when the loop is being run with no-load, but when loaded, slack is created and the shaft and wheel will not turn.

To check chain tension in this manner, stop loop system operation, shut off power and lockout power source. Remove one of the bearing caps from the traction wheel bearing shaft. Start loop system operation and note if shaft is turning (See Fig. 5A). Run both no-load and loaded to help determine proper tension. Adjust chain tension accordingly. Replace bearing cap prior to continuous operation.

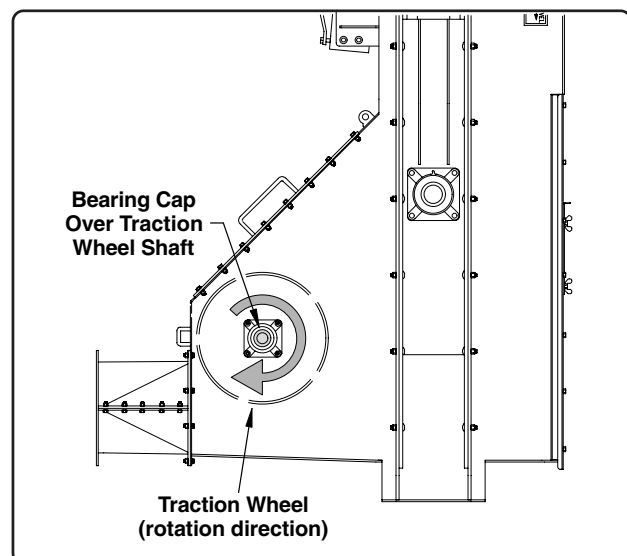
**Fig. 5A**

BEARING LUBRICATION

The bearings used in the various components of the loop system are equipped with lubrication fittings (grease zerks).

These bearings are self-aligning, sealed ball bearings which have been packed at the factory. They should be lubricated at approximately **fifty (50) hour intervals** with an SAE multipurpose type grease (See Fig. 6, Fig. 7, Fig. 8 & Fig. 9).

Typically only 1 pump is sufficient, Do Not over grease as this may damage the seals on the bearings.

Inspect bearings closely for wear and/or seal damage. Check that the bearings and lock collars are firmly fastened.

These bearings use an eccentric type lock collar. To tighten this type of lock collar, first slide it against the cam end of the inner ring of the bearing. Rotate collar in the direction of shaft rotation until the cams engage. Tap the collar further into this rotation to lock it, then tighten the setscrew.

Check all setscrews and hardware for tightness.

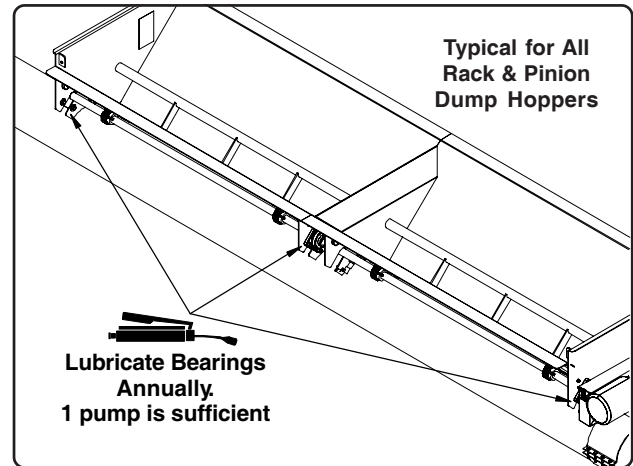

Fig. 7

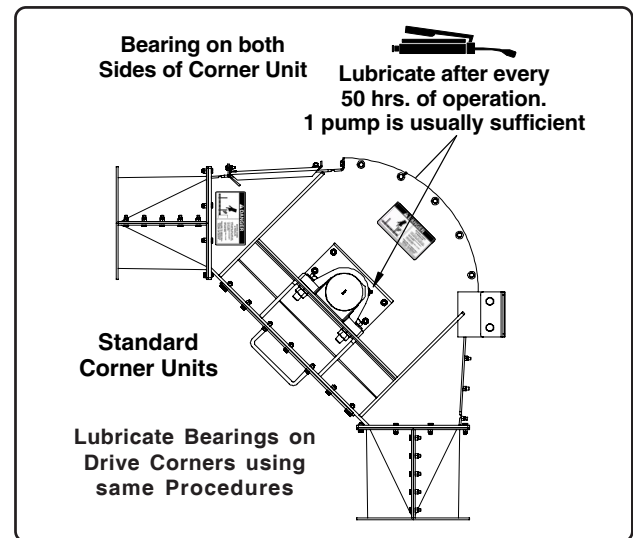

Fig. 8

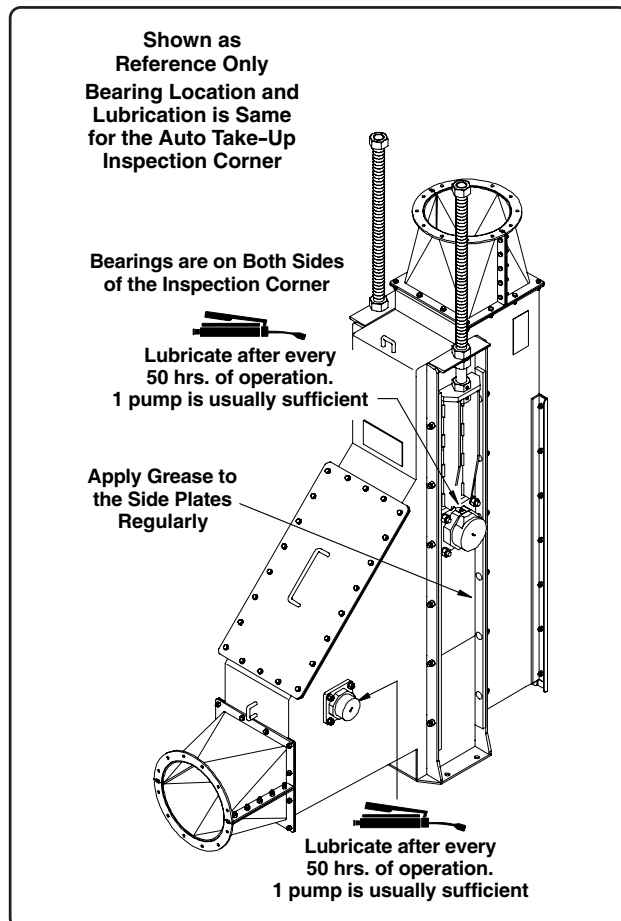

Fig. 6

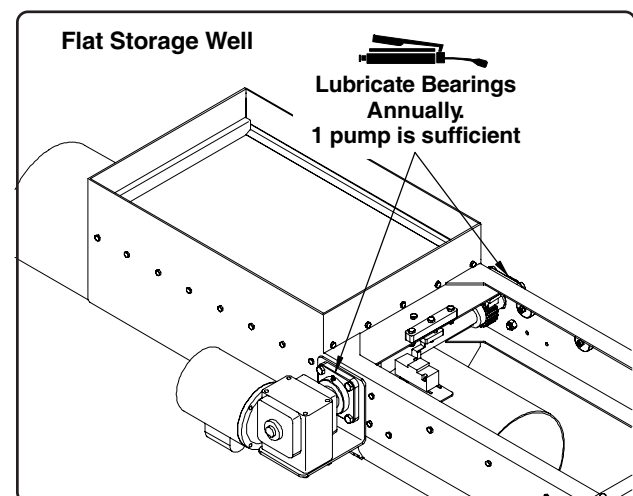

Fig. 9

LOOP SYSTEM & DROP ASSEMBLIES

Check hardware and fasteners to make sure they are all in place and secure.

For ground control discharge drops, ensure cables or chains are properly routed around the sprocket and pulleys (rollers) and operate freely.

Check connecting bands to ensure they are secure.

Ensure all hardware securing the towers and other support systems are tight and properly installed.

DRIVE CORNER BELTS

WARNING! A main power disconnect switch that can be locked in only the "OFF" position shall be provided. This shall be locked whenever work is being done on the conveyor.

The drive belt tension should be checked regularly. Check belts for tightness, cracking, fraying or other damage. Replace as necessary.

To tighten belts, turn the 3/4" nuts on the motor mount rods to raise the motor mount assembly (See Fig. 10). Raise all the rods the same distance so the motor mount assembly is parallel with top of conveyor trunking.

Proper tension is **1/2" (13 mm)** of deflection per belt when belts are firmly pressed at the center of the span between the two sheaves.

Sheaves must be aligned with each other. Check alignment by placing straight edge across the outer face of both sheaves.

Check that drive keys are properly installed and mounting bolts in sheave taper lock bushings are tight.

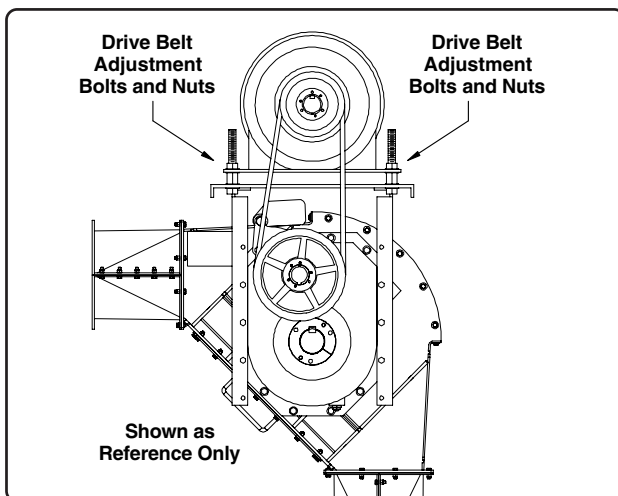

Fig. 10

AUTO TAKE-UP CORNER

If the conveyor is equipped with an Auto Take-up on the inspection corner, the take-up slide mechanism needs to be inspected and lubricated regularly.

There are four lubrication fittings (grease zerk) for the slide mechanism located on each side of the inspection corner (See Fig. 11). **These fittings should be lubricated after approximately every 10 hrs. of operation. 1 to 2 pumps of an SAE multi-purpose grease is typically sufficient.**

The sprocket and carriage assembly will go through an up/down cycle when the conveyor is started; therefore the free travel of the sprocket carriage must be maintained.

Be sure that the sprocket carriage is not fully bottomed out. If the carriage is in the full down position, then it may be necessary to shorten the chain by removing one or more links to tighten the chain. (Refer to "Conveyor Chain" information for proper chain tension.)

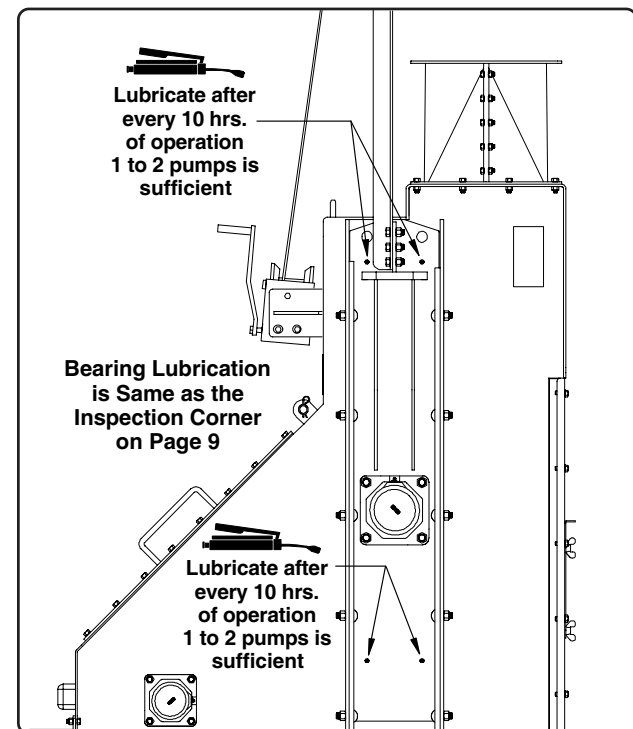

Fig. 11

DRIVE AND CORNER SPROCKETS

The conveyor chain sprockets should be occasionally checked against sliding on the shaft. The sprockets must be centered in the middle of the housing.

Ensure the sprockets are centered in the housing and the setscrews are tight securing the sprocket into place.

GEAR REDUCER

IMPORTANT! Because the gear reducer is shipped **without oil**, it is necessary to add the proper amount of oil before conveyor operation. Use a high grade petroleum base, rust and oxidation inhibiting (R & D) gear oil. **Follow the instructions on the reducer name plate, warning tags, and in the instruction manual provided with the reducer.**

Under normal industrial operating conditions, the lubricant should be changed every **2500 hours of operation or every six (6) months**, whichever occurs first. Drain the reducer and flush it with kerosene, clean the magnetic drain plug and refill reducer to its proper level with new lubricant.

CAUTION: Too much oil will cause overheating and too little oil will result in gear failure. Check oil level regularly

Under extreme operating conditions, such as rapid rise and fall of temperature, dust, dirt, chemical particles, chemical fumes, or oil pump temperatures above 200°F (93.3°C), the oil should be changed every **1 to 3 months** depending on severity of conditions.

For reducers operating in ambient temperatures that range between -22°F (-30°C) and 20°F (-6.6°C), the use of a synthetic hydrocarbon lubricant, 100 grade or AGMA 3 grade (for example, Mobil SHC627) is recommended.

Capacities:

Reducer TA5215H15 f/ 50 HP (37 kw) system approx. 12.9 qts. (12.2 l)

Reducer TA6307H15 f/ 60 HP (45 kw) system approx. 15.8 qts. (15.0 l)

Reducer TA6307H15 f/ 75 HP (55 kw) system approx. 15.8 qts. (15.0 l)

Reducer TA7315H15 f/ 100 HP (75 kw) system approx. 10.8 qts. (10.3 l)

The reducer gearboxes are positioned as shown in the manual provided with the gearboxes. All gearboxes are the “double reduction” series. The 50 HP, 60 HP and 75 HP reducers are oriented in Position “D”, the 100 HP reducer is oriented in Position “B”.

Note: These oil fill levels apply to loop systems which are installed vertically. For angled loop systems consult the manual provided with the gearbox for proper oil level.

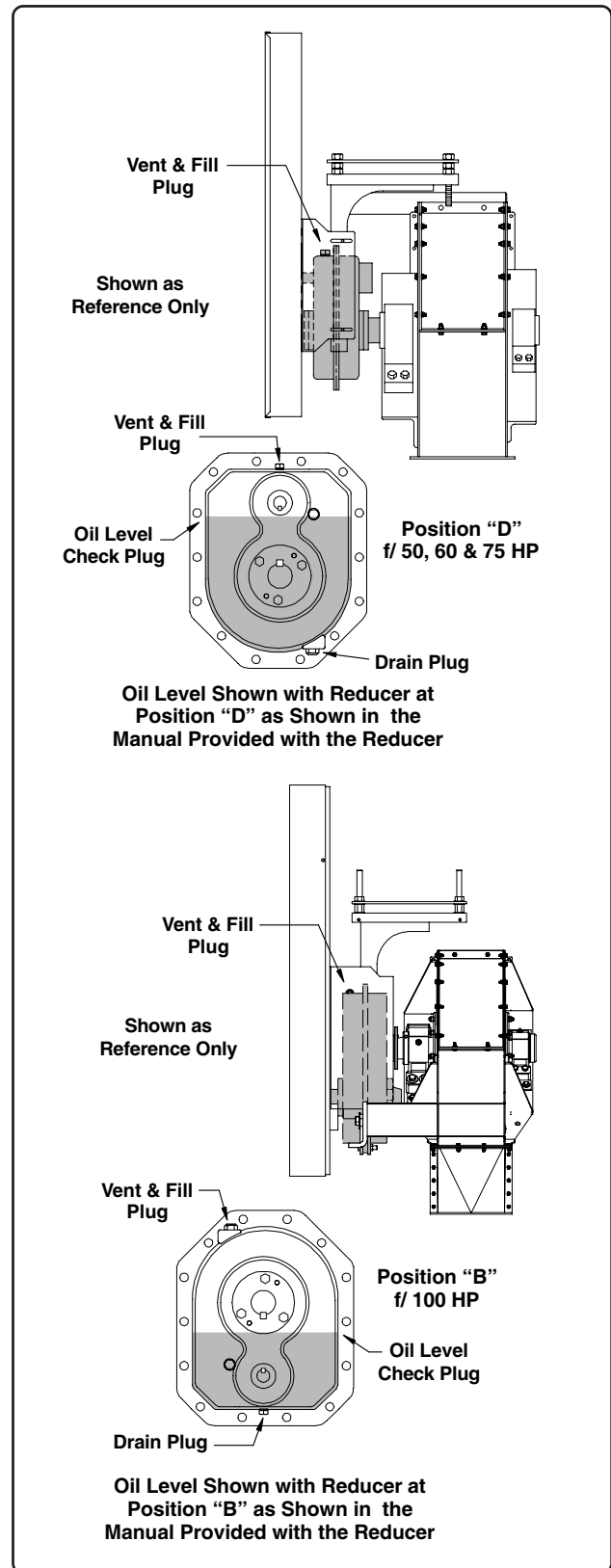

Fig. 12

RACK & PINION

The rack & pinion control does require a little maintenance. The handle for intermediate wells is supported with bronze bushings. A lubricant spray can be used on these bearings every **6 months or annually** depending on severity of operation. Also spray the clutch and shaft **annually** to ensure proper movement of the clutch assembly (commercial units).

The handle and shaft for middle well gate operation is supported with ball type bearings that include a grease fitting (grease zerk) for lubrication. These bearings should be lubricated **annually** using an SAE multi-purpose type grease. **Typically 1 pump is sufficient. Do Not over grease as this may damage the seals on the bearings.**

Check all controller hardware for tightness and ensure all sprockets are centered and aligned properly. Check that all setscrews are tight.

A **chain lubricant** should be used to keep the chains rust free and in good operating condition. This procedure should be performed **every 6 months or annually (Standard and Commercial R&P).**

Depending on severity of operating conditions the above steps should be performed more frequently to ensure proper operation.

For units using the electric rack & pinion, lubrication is the same as stated above. Also check all electrical connections/wiring for tightness and/or damage.

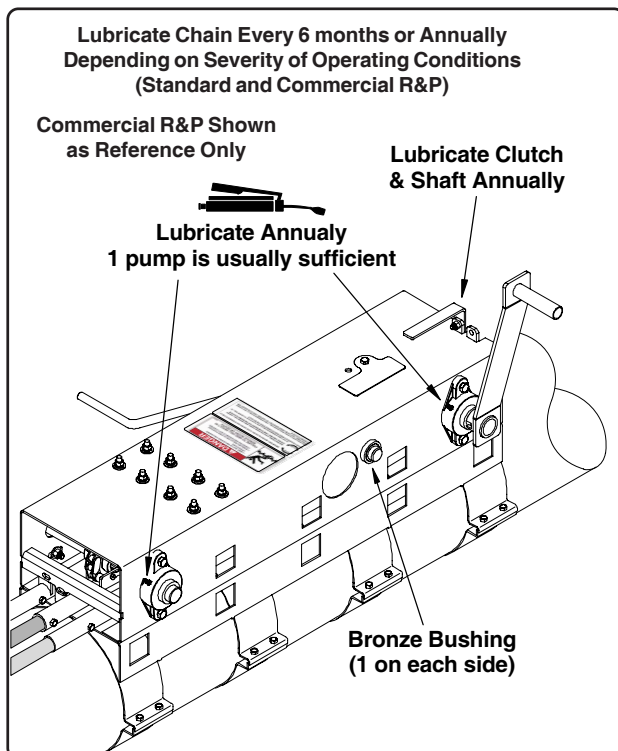

Fig. 13

TROUBLE SHOOTING**1. Extreme noise from housing.**

- Conveyor chain is too loose. Chain is slipping at drive sprocket. Check chain tension and adjust, as necessary.
- Improper assembly or misalignment of housing. Locate tube connection(s) that is the source of noise and disassemble. Check for end smoothness and grind, if necessary.
- A conveyor sprocket is not centered in a corner unit causing paddles to rub hard on conveyor sides. Sprocket must be moved on shaft to center position and locked.

2. Belt slippage on electric drive.

- Incorrect belt tension. Turn the adjustment bolts on the motor mount until proper tension is reached.
- Unit is plugged. Clear the grain and any obstructions from the machine as is possible.

3. Grain returning to the intake.

- All discharge spout gates may be closed. Make sure the proper gate is open.
- Partially blocked discharge; remove obstruction.
- Chain travel is too fast causing grain carry-over.

4. Unit not running to full capacity.

- Grain is high in moisture causing lower capacity. Excessive feeding of high moisture grain can cause plugging.
- Chain speed is too slow.
- Obstruction at intake.
- There is grain returning to the intake (See 3 above).

5. Paddle breaking or bending.

- Paddles may be coming loose from the chain. Keep paddles securely connected to chain.
- Housing misalignment.
- Frequent starts under loads. Allow machine to clean out before shutting down.
- Sprockets may be off center. Align in center of housing.
- Overfeeding; adjust the feeding of the unit to allow less grain to enter while maintaining full speed.

INSTALLATION

The purpose of this section is to advise and instruct owners on how the equipment can be installed.

A millwright or other experienced contractor should perform the installation. **The installer should read this manual and understand the complete operation of the equipment.**

INSTALLATION INFORMATION

- All systems require the joining of four or more sections of tubular conveyor housing.
- All systems will include four 90° corners.
- The 90° discharge with gate includes either a 12 ft. (3.66 m) or 15 ft. (4.57 m) long section of tubular conveyor housing that must be fit within other tubular conveyor so the discharge is located properly.
- The inlet dump hoppers include a length of tubular conveyor housing that must fit within other tubular housing so the hopper is located properly.
- Wells used in grain bin floors fasten onto standard tubular conveyor housing. Access openings must be cut in the tubing to install wells.

LAYOUT

Grain Pump® Systems are usually installed around rows of storage structures, with access for vehicle or rail traffic and other devices.

Grain bins may be conventional or elevated on a supporting structure with hopper bottoms.

Grain dryers, cleaners or other devices may have access to the system.

Systems have been used to transfer between trucks and rail cars with several temporary storage tanks included.

The Grain Pump® conveyor can be used in many different ways and operation can vary from installation to installation.

Thought given to proper grain system layout prior to conveyor installation can prevent later problems in the grain flow plan and avoid possible “bottle-necks”.

A layout should be made to determine the exact location of conveyor, inlets, outlets, power source, support and mounting locations.

The illustration on Page 16 shows some of the various components that can be used with your system. Consideration during the layout process should be given to their location if any of them are to be used in your application.

LAYOUT (con't.)

Dimensional information of components is found in the Parts List Section beginning on Page P-3.

IMPORTANT! If using the chain access assembly, it is recommended that it be installed on a horizontal section of the loop system.

LAYOUT CONSIDERATIONS

Following are major items that should be considered when laying out the system:

- A. Type of material to be conveyed.
- B. Volume of material to be conveyed [bushels (*tons*) per hour].
- C. Location and amount of material fed into system.
- D. Location and number of outlets.
- E. How will the conveyor be supported?
- F. Further expansion. Will more bins be added and where?
- G. The direction of grain flow.

Use these general guidelines to help layout your conveyor system:

- Grain pumps are designed to move grain in one direction only.
- Leave adequate room to perform periodic maintenance.
- The conveyor will handle a wide range of free flowing grains. It should not be used with highly corrosive material, such as fertilizer. The life of the conveyor chain will be shortened when the chain is allowed to sit in water or is operated in acidic conditions, so avoid these situations.
- Be sure not to overfeed the conveyor. This will cause plugging. Intake rate should not exceed the particular capacity of the conveyor.
- It is important that a firm, level foundation or support structure be provided on which the conveyor can be mounted. This support should be ample to carry the load of the conveyor when fully loaded.
- Locate outlets where connecting bands will not interfere with outlets or control. **Do Not cut or modify tube connecting bands.**

ASSEMBLY INSTRUCTIONS

LAYOUT INFORMATION

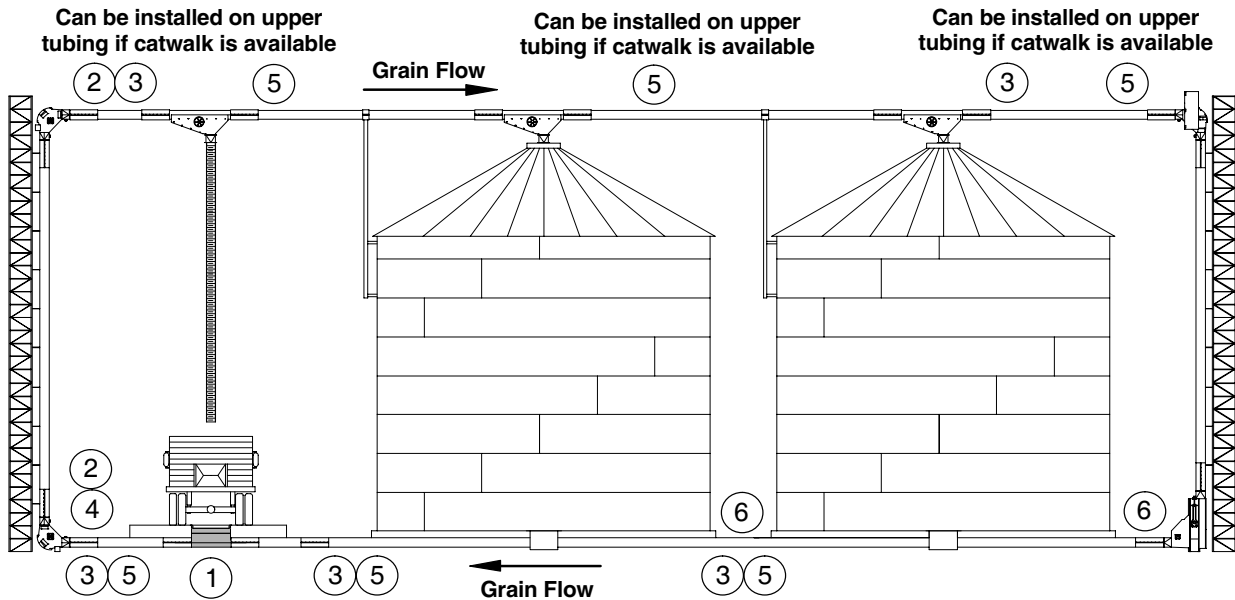

2 Grate Dump Hopper
(also 5, 6 and 7 grate hoppers)

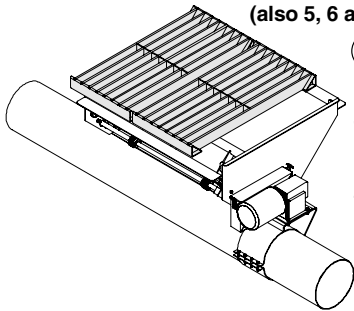

1

Typically located near standard corner where chain and paddles turn to carry grain into the system.

Chain Inspection Access
(horizontal installation only)

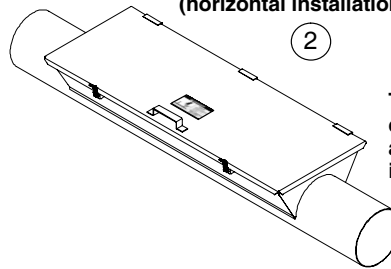

2

Typically located near standard corner after dump hopper, can also be installed in upper tubing if a catwalk is available

Connecting Band w/ Inspection Port

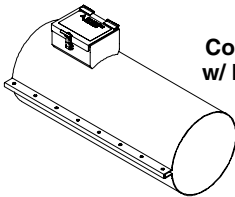

3

Typically located near standard corner, usually after dump hopper (must be installed in horizontal tube). Can also be installed in upper horizontal tubing if a catwalk is available .

Inlet Hopper

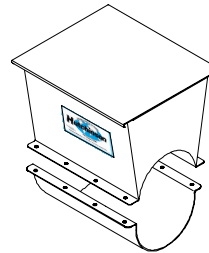

4

Used mainly for dumping grain into the system without using the drive-over dump hopper. Typically located near standard corner or outside of the loop system tying into another loop system.

Inspection Hopper

5

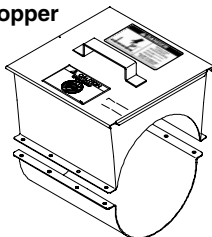

Generally installed after dump hopper or each bin. Can basically be installed anywhere along the horizontal tube of the loop system to view grain flow.

Rack & Pinion Control

6

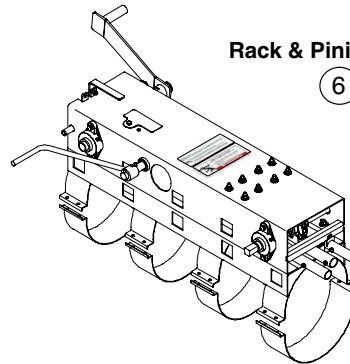

Located outside of grain gin or storage structure close to outside wall. Opens and closes center and intermediate well gates.

SYSTEM SUPPORT INFORMATION

Towers or other adequate supports are needed to hold the vertical ends of the Grain Pump® System in position. Consider the weight per foot (*meter*) of a fully loaded tubular conveyor, based on 56 lb. per bu. of material (*720 kg per cu. meter*), the individual corners and all other components, particularly the ones with drives which weigh considerably more.

The horizontal tubular conveyor should be supported at 20 ft. to 30 ft. (*6.10 to 9.14 m*) intervals. This can be done with vertical supports from the ground, from the bin side walls or from the bin roof at the peak. **Consult the bin manufacturer concerning their recommendations for loads their bin will support in these areas.**

**Weight per foot (*meter*) of tubular conveyor:
Single Chain**

Conveyor Tubing Empty - 26.5 lbs./ft. (*39.4 kg/m*)
Conveyor Tubing Fully Loaded - 63 lbs./ft. (*93.7 kg/m*)

**Weight per foot (*meter*) of tubular conveyor:
Double Chain**

Conveyor Tubing Empty - 31 lbs./ft. (*46.1 kg/m*)
Conveyor Tubing Fully Loaded - 67.5 lbs./ft. (*100.4 kg/m*)

GRAIN FLOW AND DRIVE CORNER LOCATION

Grain Pump® Loop Systems will include one or two drive corners. The drive corner, on systems with one (shown in the illustration below), must be located at the overhead point toward which the overhead chain will travel. On systems with two drive corners locate them at the two overhead positions.

The inspection corner includes the adjustable slide that is used to tighten the conveyor chain. Locate the inspection corner on the bottom at the end where the conveyor chain travels down from top to bottom. The inspection corner also provides access to the conveyor chain and paddles for periodic maintenance.

There will be one or two standard corners, depending on the number of drive corners. They will be located at the end where the conveyor chain moves up carrying grain from the bottom to the top. When there are two drives, there is only one standard corner located at the bottom.

The system should be laid out to minimize the distance grain must be moved to perform the necessary loading and unloading operation. In the example, the dump hopper is located next to the end where the grain will be carried up to the overhead part of the system. If the dump hopper were located at the other end of the system the grain must travel a greater distance in the system to reach a bin. Grain would also travel a greater distance to the load out point when unloading bins.

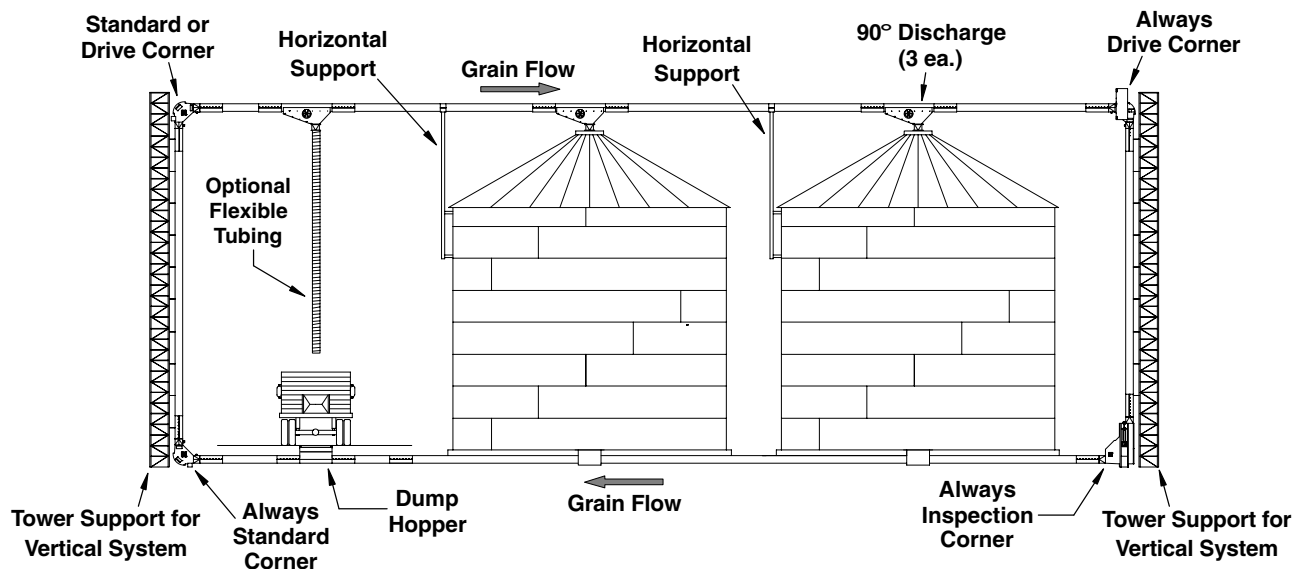

ASSEMBLY INSTRUCTIONS

TUBE AND CORNER ASSEMBLY

Lay the tubing and corner sections out in order so as to determine what portions to assemble prior to actual placement in the system.

When cutting tubes to exact length, the ends must be cut square and any burrs on the ends removed. Attach flanged tubes to corner assembly with 3/8" x 1" bolts and nylon locknuts. Join flanged tubes and conveyor tubing together with connecting bands (slide the tube sections tight together). Tighten the 3/8" x 1 1/2" bolts and nylon locknuts in the connecting bands.

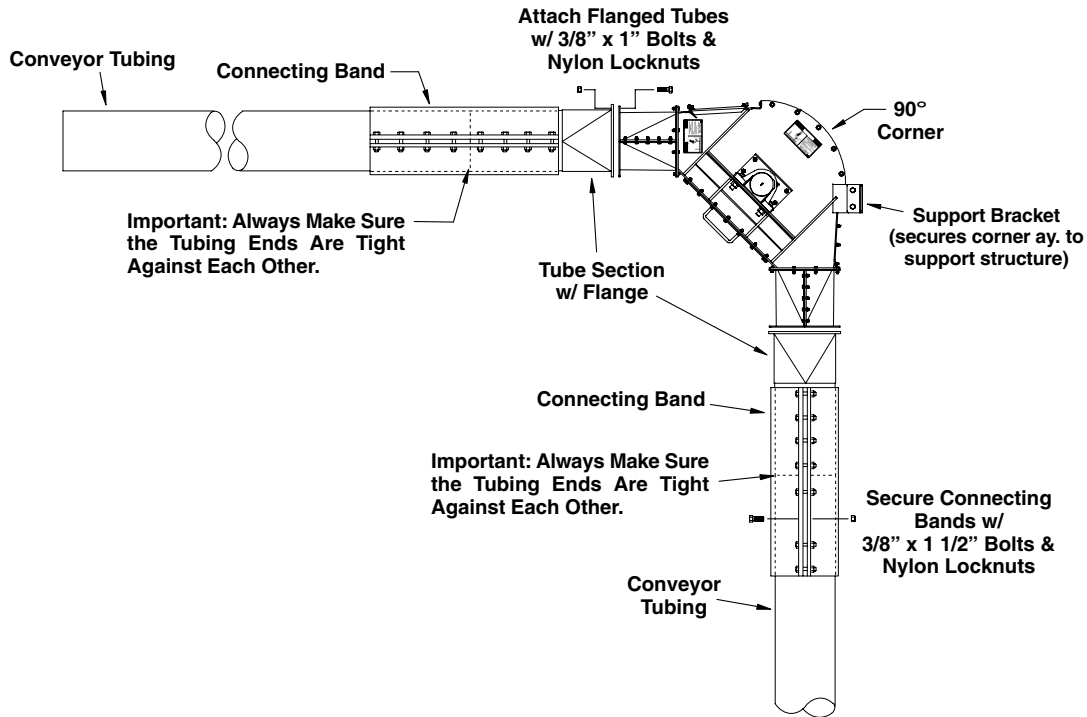

DISCHARGE WITH GATE ASSEMBLY

The discharge unit includes either a 12 ft. or 15 ft. (3.66 m or 4.57 m) long section of conveyor tube. Locate the outlet of the discharge in the desired location. It may be necessary to cut exact lengths of other tube conveyor sections to locate the discharge unit in its proper place.

The discharge with gate is designed for chain travel through in only one direction. Make sure it is oriented properly by comparing the appearance to the diagram or referring to a label on the discharge unit. Operation in the wrong direction can cause paddle damage.

Fasten the discharge in place within the tubular conveyor with connecting bands. Secure using 3/8" x 1 1/2" bolts and nylon locknuts.

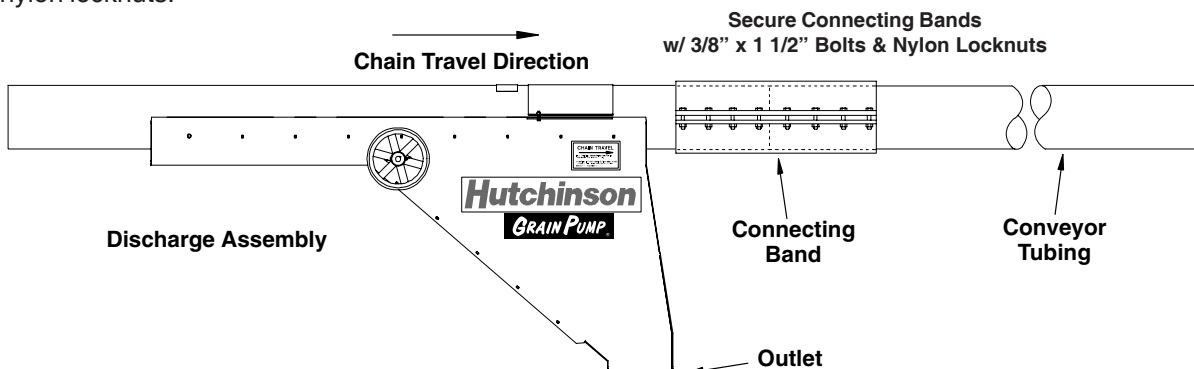

BIN WELL ASSEMBLY (Commercial Bin Wells)

Lay the sections of conveyor tubing in the bin according to your particular application (for example: will tubing be passing through the bin below a floor, or through a concrete trough under the bin). Whatever method is used, the tubing needs to pass exactly through the center of the bin. If applicable, cut opening(s) in bin wall to allow tubing to pass through. Use connecting bands to attach the tubing together.

Position the **center bin well** so the bin sweep mounting tube is in the exact center of the bin (See illustration below), **make sure the flow control gate is in a direction that can be pulled by the control rods**. Place suitable support beneath the well to hold it in position (the support will also help to relieve pressure on a raised floor when the well fills with grain).

Slide the connecting bands onto the center well tubes and connect the conveyor tubing to the center well. Make sure the ends of the conveyor tubing contacts the ends of the center well tubes and tighten connecting bands (secure the connecting bands using 5/16" x 1 1/2" bolts and non-lock nuts).

The intermediate wells will be positioned between the center well and the bin wall. The illustration below shows the minimum spacing allowed from the center well to the intermediate well and from the intermediate wells in relation to each other. Use the charts on pages 21, 22, 23 & 24 as a guideline for well spacing as determined by bin diameter, but keep in mind if a sweep tractor is to be used, you do not want the tractor to travel over the top of a well, so it may be necessary to position an intermediate well in a location other than the recommended spacing (if the well does have to be moved, keep it as close to the intended measurement as possible). Also, note that it may be necessary to reposition an intermediate well from its intended position because of the location of the connecting band attaching the tubes together.

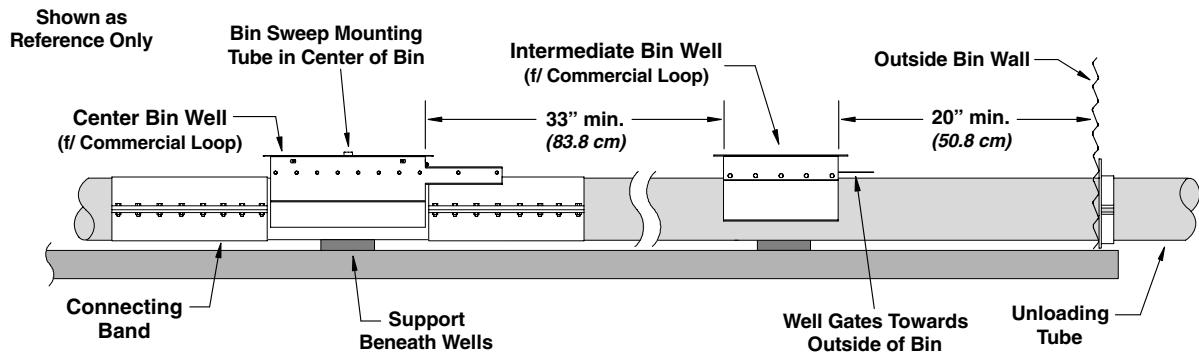

When well locations are determined on the conveyor tubing, cut an opening in the tube for each well. There should be about a 1/2" (13 mm) tube left all around the inside of the well (See illustration below). Grain will leak if the opening is cut too large. **NOTE: DO NOT cut the tube openings when the chain and paddles are inside the tube. Damage to the chain and/or paddles can occur.**

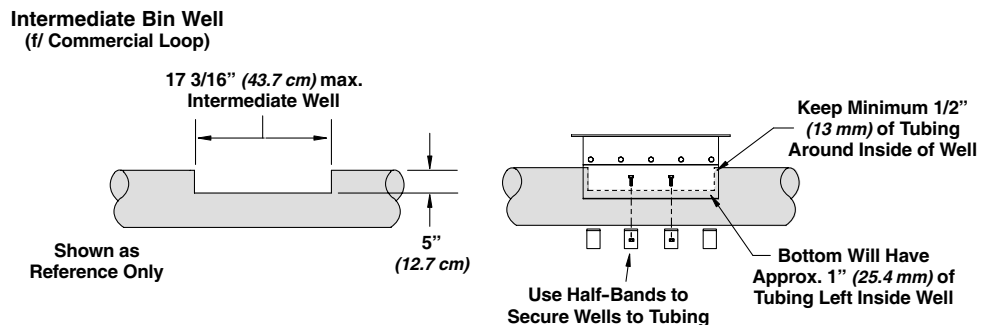

Secure the bin wells to the tubing using the half-bands and 5/16" x 1-1/2" bolts and non-lock nuts. Be sure the tops of the wells are level after they have been attached to the conveyor tube.

Place suitable support beneath the wells to hold into position. **The supports used should be of a material that will not deteriorate, ie. brick, treated 2x4, etc.**

ASSEMBLY INSTRUCTIONS

BIN WELL ASSEMBLY (Standard Bin Wells)

Lay the sections of conveyor tubing in the bin according to your particular application (for example: will tubing be passing through the bin below a floor, or through a concrete trough under the bin). Whatever method is used, the tubing needs to pass exactly through the center of the bin. If applicable, cut opening(s) in bin wall to allow tubing to pass through. Use connecting bands to attach the tubing together.

Position the center bin well on top of the conveyor tube so the bin sweep mounting tube is in the exact center of the bin (See illustration below), **make sure the flow control gate is in a direction that can be pulled by the control rods.**

The intermediate wells will be positioned between the center well and the bin wall. The illustration below shows the minimum spacing allowed from the center well to the intermediate well and from the intermediate wells in relation to each other. Use the charts on pages 21, 22, 23 & 24 as a guideline for well spacing as determined by bin diameter, but keep in mind if a sweep tractor is to be used, you do not want the tractor to travel over the top of a well, so it may be necessary to position an intermediate well in a location other than the recommended spacing (if the well does have to be moved, keep it as close to the intended measurement as possible). Also, note that it may be necessary to reposition an intermediate well from its intended position because of the location of the connecting band attaching the tubes together.

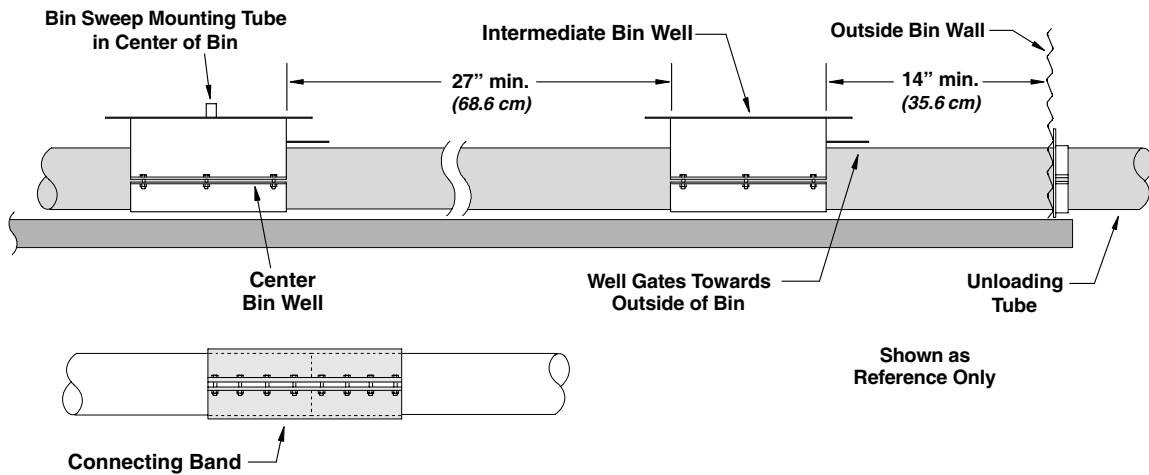

When well locations are determined on the conveyor tubing, cut an opening in the tube for each well. There should be about a 1/2" (13 mm) tube left all around the inside of the well (See illustration below). Grain will leak if the opening is cut too large.

NOTE: DO NOT cut the tube openings when the chain and paddles are inside the tube. Damage to the chain and/or paddles can occur.

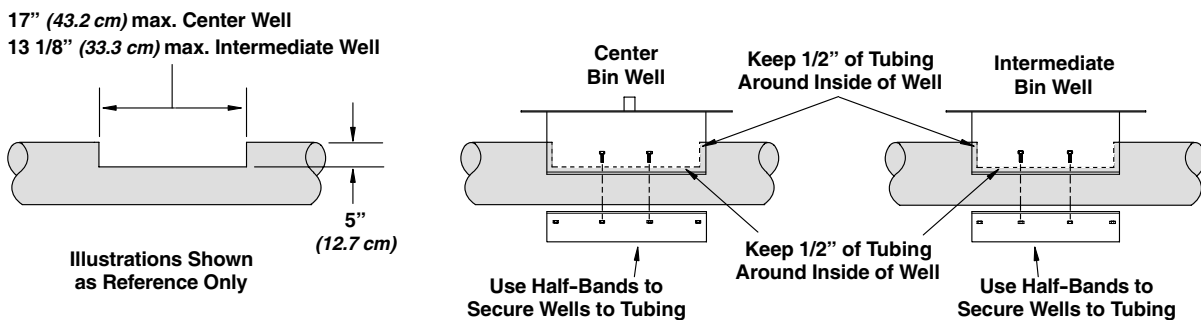

Secure the bin wells to the tubing using the back bands and eight 5/16" x 1-1/2" bolts and non-lock nuts. Be sure the tops of the wells are level after they have been attached to the conveyor tube. Place suitable support beneath the wells to hold into position. **The supports used should be of a material that will not deteriorate, ie. brick, treated 2x4, etc.**

ASSEMBLY INSTRUCTIONS

BIN WELL ASSEMBLY (con't.)

Bin Well Location & Control Pipe Information (see charts on Pages 22, 23 & 24 for dimensions)

24' to 34' (7.32 m – 10.36 m) Dia. Bins

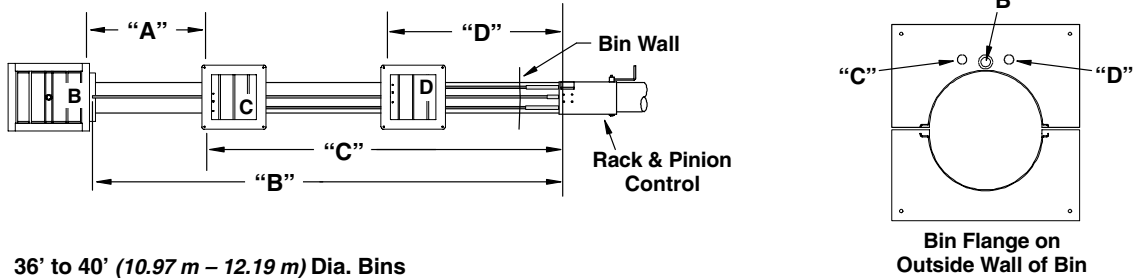

36' to 40' (10.97 m – 12.19 m) Dia. Bins

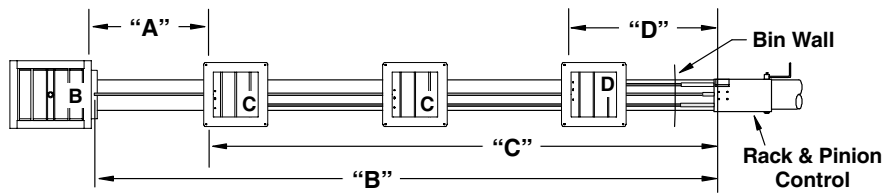

42' to 90' (12.80 m – 27.43 m) Dia. Bins

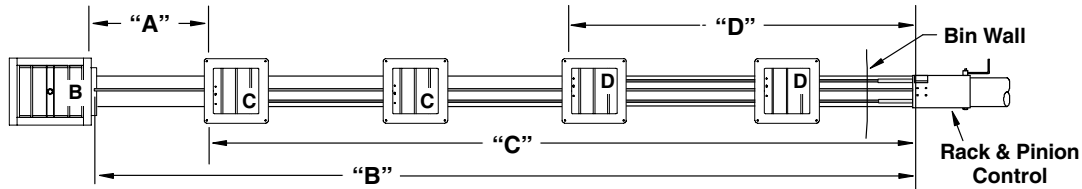

92' to 105' (28.04 m – 32.00 m) Dia. Bins

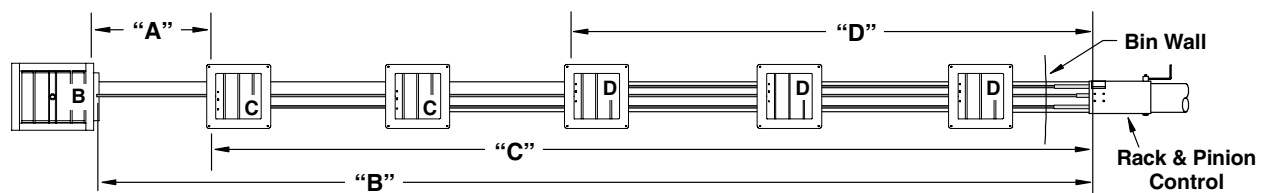

113' to 120' (34.44 m – 36.58 m) Dia. Bins

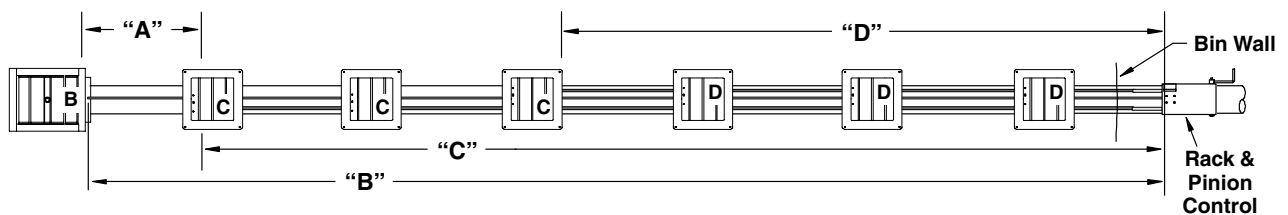

ASSEMBLY INSTRUCTIONS

BIN WELL ASSEMBLY (con't.)

Bin Dia.	Spacing Between Inter. Wells "A"	No. of Inter. Wells	Length of Control Pipes	
			Center Well Pipe Assembly "B"	
			Assy. Length "B"	Length of Sections "B"
24' (7.32 m)	31 1/2" (80 cm)	2	11'-11 1/2" (3.64 m)	11'-11 1/2" (3.64 m)
27' (8.23 m)	38 1/2" (98 cm)	2	13'-5 1/2" (4.10 m)	13'-5 1/2" (4.10 m)
30' (9.14 m)	45 1/2" (1.16 m)	2	14'-11 1/2" (4.56 m)	14'-11 1/2" (4.56 m)
34' (10.36 m)	55 1/2" (1.41 m)	2	16'-11 1/2" (5.17 m)	16'-11 1/2" (5.17 m)
36' (10.97 m)	35 1/2" (90.2 cm)	3	17'-11 1/2" (5.47 m)	17'-11 1/2" (5.47 m)
39' (11.89 m)	40 1/2" (1.03 m)	3	19'-5 1/2" (5.93 m)	19'-5 1/2" (5.93 m)
40' (12.19 m)	42 1/2" (1.08 m)	3	19'-11 1/2" (6.08 m)	19'-11 1/2" (6.08 m)
42' (12.80 m)	29 1/2" (74.9 cm)	4	20'-11 1/2" (6.39 m)	20'-11 1/2" (6.39 m)
49' (14.94 m)	38 1/2" (98 cm)	4	24'-5 1/2" (7.45 m)	21'-0" (6.40 m) & 3'-5 1/2" (1.05 m)
55' (16.76 m)	46 1/2" (1.18 m)	4	27'-5 1/2" (8.57 m)	21'-0" (6.40 m) & 6'-5 1/2" (1.97 m)
60' (18.29 m)	*53 1/2" (1.36 m)	4	29'-11 1/2" (9.13 m)	21'-0" (6.40 m) & 8'-11 1/2" (2.73 m)
63' (19.20 m)	*57 1/2" (1.46 m)	4	31'-5 1/2" (9.59 m)	21'-0" (6.40 m) & 10'-5 1/2" (3.19 m)
68' (20.73 m)	65 1/2" (1.66 m)	4	34'-5 1/2" (10.50 m)	21'-0" (6.40 m) & 13'-5 1/2" (4.10 m)
72' (21.95 m)	69 1/2" (1.77 m)	4	35'-11 1/2" (10.96 m)	21'-0" (6.40 m) & 14'-11 1/2" (4.56 m)
75' (22.86 m)	73 1/2" (1.87 m)	4	36'-5 1/2" (11.11 m)	21'-0" (6.40 m) & 16'-5 1/2" (5.02 m)
78' (23.77 m)	77 1/2" (1.97 m)	4	38'-9 1/2" (11.82 m)	21'-0" (6.40 m) & 18'-9 1/2" (5.73 m)
80' (24.38 m)	80 1/2" (2.04 m)	4	39'-9 1/2" (12.13 m)	21'-0" (6.40 m) & 19'-9 1/2" (6.03 m)
82' (24.99 m)	82 1/2" (2.10 m)	4	41'-9 1/2" (12.74 m)	21'-0" (6.40 m) & 20'-9 1/2" (6.34 m)
90' (27.43 m)	*93 1/2" (2.37 m)	4	45'-9 1/2" (13.96 m)	21'-0" (6.40 m) & 21'-0" (6.40 m) & 3'-9 1/2" (1.16 m)
92' (28.04 m)	73 1/2" (1.87 m)	5	46'-9 1/2" (14.26 m)	21'-0" (6.40 m) & 21'-0" (6.40 m) & 4'-9 1/2" (1.46 m)
105' (32.00 m)	*88 1/2" (2.25 m)	5	53'-3 1/2" (16.24 m)	21'-0" (6.40 m) & 21'-0" (6.40 m) & 11'-3 1/2" (3.44 m)
113' (34.44 m)	*77 1/2" (1.97 m)	6	57'-3 1/2" (17.46 m)	21'-0" (6.40 m) & 21'-0" (6.40 m) & 15'-3 1/2" (4.66 m)
120' (36.58 m)	84 1/2" (2.15 m)	6	60'-9 1/2" (18.53 m)	21'-0" (6.40 m) & 21'-0" (6.40 m) & 18'-9 1/2" (6.03 m)

* Spacing between wells may vary due to connecting band being located where wells would be located if equally spaced.

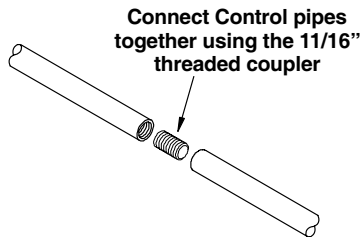

Control Pipe Part No's.

3' 5 1/2"	53821	16' 5 1/2"	53839
3' 9 1/2"	53818	16' 11 1/2"	53810
4' 9 1/2"	53823	17' 11 1/2"	53799
6' 5 1/2"	53825	18' 9 1/2"	53841
8' 11 1/2"	53828	19' 5 1/2"	53843
10' 5 1/2"	53819	19' 9 1/2"	53842
11' 3 1/2"	53832	19' 11 1/2"	53808
11' 11 1/2"	53833	20' 9 1/2"	53844
13' 5 1/2"	53835	20' 11 1/2"	53813
14' 11 1/2"	53837	21' 0"	53845
15' 3 1/2"	53836		

BIN WELL ASSEMBLY (con't.)

Bin Dia.	Spacing Between Inter. Wells "A"	No. of Inter. Wells	Length of Control Pipes	
			Inner Intermediate Well Pipe Assembly "C"	
			Assy. Length "C"	Length of Sections "C"
24' (7.32 m)	31 1/2" (80 cm)	2	8'-2 1/2" (2.50 m)	8'-2 1/2" (2.50 m)
27' (8.23 m)	38 1/2" (98 cm)	2	9'-1 1/2" (2.78 m)	9'-1 1/2" (2.78 m)
30' (9.14 m)	45 1/2" (1.16 m)	2	10'-1/2" (3.06 m)	10'-1/2" (3.06 m)
34' (10.36 m)	55 1/2" (1.41 m)	2	11'-2 1/2" (3.42 m)	11'-2 1/2" (3.42 m)
36' (10.97 m)	35 1/2" (90.2 cm)	3	13'-10 1/2" (4.23 m)	13'-10 1/2" (4.23 m)
39' (11.89 m)	40 1/2" (1.03 m)	3	14'-11 1/2" (4.56 m)	14'-11 1/2" (4.56 m)
40' (12.19 m)	42 1/2" (1.08 m)	3	15'-3 1/2" (4.66 m)	15'-3 1/2" (4.66 m)
42' (12.80 m)	29 1/2" (74.9 cm)	4	17'-4 1/2" (5.30 m)	17'-4 1/2" (5.30 m)
49' (14.94 m)	38 1/2" (98 cm)	4	20'-1 1/2" (6.13 m)	20'-1 1/2" (6.13 m)
55' (16.76 m)	46 1/2" (1.18 m)	4	22'-5 1/2" (6.85 m)	21'-0" (6.40 m) & 1'-5 1/2" (44.5 cm)
60' (18.29 m)	*53 1/2" (1.36 m)	4	24'-4 1/2" (7.43 m)	21'-0" (6.40 m) & 3'-4 1/2" (1.03 m)
63' (19.20 m)	*57 1/2" (1.46 m)	4	25'-6 1/2" (7.79 m)	21'-0" (6.40 m) & 4'-6 1/2" (1.38 m)
68' (20.73 m)	65 1/2" (1.66 m)	4	27'-10 1/2" (8.50 m)	21'-0" (6.40 m) & 6'-10 1/2" (2.10 m)
72' (21.95 m)	69 1/2" (1.77 m)	4	29'-1/2" (8.85 m)	21'-0" (6.40 m) & 8'-1/2" (2.45 m)
75' (22.86 m)	73 1/2" (1.87 m)	4	30'-2 1/2" (9.21 m)	21'-0" (6.40 m) & 9'-2 1/2" (2.81 m)
78' (23.77 m)	77 1/2" (1.97 m)	4	32'-2 1/2" (9.82 m)	21'-0" (6.40 m) & 11'-2 1/2" (3.42 m)
80' (24.38 m)	80 1/2" (2.04 m)	4	32'-11 1/2" (10.05 m)	21'-0" (6.40 m) & 11'-11 1/2" (3.64 m)
82' (24.99 m)	82 1/2" (2.10 m)	4	33'-9 1/2" (10.30 m)	21'-0" (6.40 m) & 12'-9 1/2" (3.90 m)
90' (27.43 m)	*93 1/2" (2.37 m)	4	36'-10 1/2" (11.24 m)	21'-0" (6.40 m) & 15'-10 1/2" (4.84 m)
92' (28.04 m)	73 1/2" (1.87 m)	5	38'-6 1/2" (11.75 m)	21'-0" (6.40 m) & 18'-6 1/2" (5.65 m)
105' (32.00 m)	*88 1/2" (2.25 m)	5	44'-9 1/2" (13.65 m)	21'-0" (6.40 m) & 21'-0" (6.40 m) & 2'-9 1/2" (85.1 cm)
113' (34.44 m)	*77 1/2" (1.97 m)	6	49'-8 1/2" (15.15 m)	21'-0" (6.40 m) & 21'-0" (6.40 m) & 7'-8 1/2" (2.35 m)
120' (36.58 m)	84 1/2" (2.15 m)	6	52'-7 1/2" (16.04 m)	21'-0" (6.40 m) & 21'-0" (6.40 m) & 10'-7 1/2" (3.24 m)

* Spacing between wells may vary due to connecting band being located where wells would be located if equally spaced.

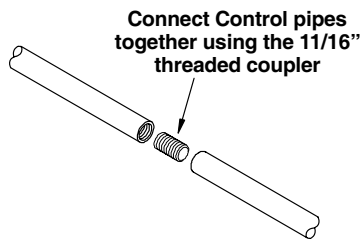

Control Pipe Part No's.

1' 5 1/2" 53815	11' 2 1/2" 53831
2' 9 1/2" 53817	11' 11 1/2" ... 53833
3' 4 1/2" 53820	12' 9 1/2" 53834
4' 6 1/2" 53824	13' 10 1/2" ... 53804
6' 10 1/2" 53846	14' 11 1/2" ... 53837
7' 8 1/2" 53826	15' 3 1/2" 53836
8' 1/2" 53827	15' 10 1/2" ... 53838
8' 2 1/2" 53790	17' 4 1/2" 53811
9' 1 1/2" 53792	18' 6 1/2" 53840
9' 2 1/2" 53829	20' 1 1/2" 53812
10' 1/2" 53796	21' 0" 53845
10' 7 1/2" 53830	

ASSEMBLY INSTRUCTIONS

BIN WELL ASSEMBLY (con't.)

Bin Dia.	Spacing Between Inter. Wells "A"	No. of Inter. Wells	Length of Control Pipes	
			Outer Intermediate Well Pipe Assembly "D"	
			Assy. Length "D"	Length of Sections "D"
24' (7.32 m)	31 1/2" (80 cm)	2	3'-4 1/2" (1.03 m)	3'-4 1/2" (1.03 m)
27' (8.23 m)	38 1/2" (98 cm)	2	3'-8 1/2" (1.13 m)	3'-8 1/2" (1.13 m)
30' (9.14 m)	45 1/2" (1.16 m)	2	4'-1 1/2" (1.23 m)	4'-1 1/2" (1.23 m)
34' (10.36 m)	55 1/2" (1.41 m)	2	4'-4 1/2" (1.33 m)	4'-4 1/2" (1.33 m)
36' (10.97 m)	35 1/2" (90.2 cm)	3	8'-8 1/2" (2.65 m)	8'-8 1/2" (2.65 m)
39' (11.89 m)	40 1/2" (1.03 m)	3	9'-4 1/2" (2.86 m)	9'-4 1/2" (2.86 m)
40' (12.19 m)	42 1/2" (1.08 m)	3	9'-6 1/2" (2.91 m)	9'-6 1/2" (2.91 m)
42' (12.80 m)	29 1/2" (74.9 cm)	4	8'-1 1/2" (2.45 m)	8'-1 1/2" (2.45 m)
49' (14.94 m)	38 1/2" (98 cm)	4	9'-3 1/2" (2.83 m)	9'-3 1/2" (2.83 m)
55' (16.76 m)	46 1/2" (1.18 m)	4	10'-3 1/2" (3.14 m)	10'-3 1/2" (3.14 m)
60' (18.29 m)	*53 1/2" (1.36 m)	4	12'-6 1/2" (3.82 m)	12'-6 1/2" (3.82 m)
63' (19.20 m)	*57 1/2" (1.46 m)	4	13'-9 1/2" (4.20 m)	13'-9 1/2" (4.20 m)
68' (20.73 m)	65 1/2" (1.66 m)	4	12'-6 1/2" (3.82 m)	12'-6 1/2" (3.82 m)
72' (21.95 m)	69 1/2" (1.77 m)	4	13'-1 1/2" (3.98 m)	13'-1 1/2" (3.98 m)
75' (22.86 m)	73 1/2" (1.87 m)	4	13'-6 1/2" (4.13 m)	13'-6 1/2" (4.13 m)
78' (23.77 m)	77 1/2" (1.97 m)	4	14'-10 1/2" (4.53 m)	14'-10 1/2" (4.53 m)
80' (24.38 m)	80 1/2" (2.04 m)	4	15'-1 1/2" (4.61 m)	15'-1 1/2" (4.61 m)
82' (24.99 m)	82 1/2" (2.10 m)	4	15'-7 1/2" (4.76 m)	15'-7 1/2" (4.76 m)
90' (27.43 m)	*93 1/2" (2.37 m)	4	18'-1 1/2" (5.52 m)	18'-1 1/2" (5.52 m)
92' (28.04 m)	73 1/2" (1.87 m)	5	22'-10 1/2" (6.97 m)	21'-0" (6.40 m) & 1'-10 1/2" (57.2 cm)
105' (32.00 m)	*88 1/2" (2.25 m)	5	25'-7 1/2" (7.81 m)	21'-0" (6.40 m) & 21'-0" (6.40 m) & 4'-7 1/2" (1.41 m)
113' (34.44 m)	*77 1/2" (1.97 m)	6	23'-8" (7.21 m)	21'-0" (6.40 m) & 21'-0" (6.40 m) & 2'-8" (81.3 cm)
120' (36.58 m)	84 1/2" (2.15 m)	6	24'-4 1/2" (7.43 m)	21'-0" (6.40 m) & 21'-0" (6.40 m) & 3'-4 1/2" (1.03 m)

* Spacing between wells may vary due to connecting band being located where wells would be located if equally spaced.

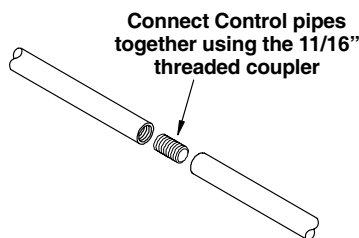

Control Pipe Part No's.

1' 10 1/2"	53814	9' 6 1/2"	53795
2' 8"	53816	12' 6 1/2"	53801
3' 4 1/2"	53820	13' 1/2"	53802
3' 8 1/2"	53787	13' 6 1/2"	53803
4' 1/2"	53788	13' 9 1/2"	53800
4' 4 1/2"	53789	14' 10 1/2"	53805
4' 7 1/2"	53822	15' 1 1/2"	53806
8' 1/2"	53827	15' 7 1/2"	53807
8' 8 1/2"	53791	18' 1 1/2"	53809
9' 3 1/2"	53793	21' 0"	53845
9' 4 1/2"	53794		

BIN WELL ASSEMBLY (con't.)

Install the upper and lower bin flange to the conveyor tubing on the outside of the bin wall. Knock out the appropriate hole(s) for the intermediate well(s) and the smaller center hole on the upper bin flange (See illustration below). Position the upper flanges onto the unload tube. Using the flange as a template, mark and cut the holes for the control pipes and the four corner mounting holes [drill an 11/32" (9 mm) dia. hole for the four mounting holes].

After the holes have been cut/drilled, apply some type of sealing material in the gap(s) around the unload tube and bin wall. Attach the bin flanges and decal plate to the bin wall using four 5/16" x 1" bolts and non-lock nuts. Secure the bin flanges to the unload tube using four 5/16" x 1 1/2" bolts and non-lock nuts.

An extra set of bin flanges can also be used on the opposite bin wall that will not have the control pipes passing through, this not only helps support the unload tubing, but also allows for a better seal around the opening cut for the tubing.

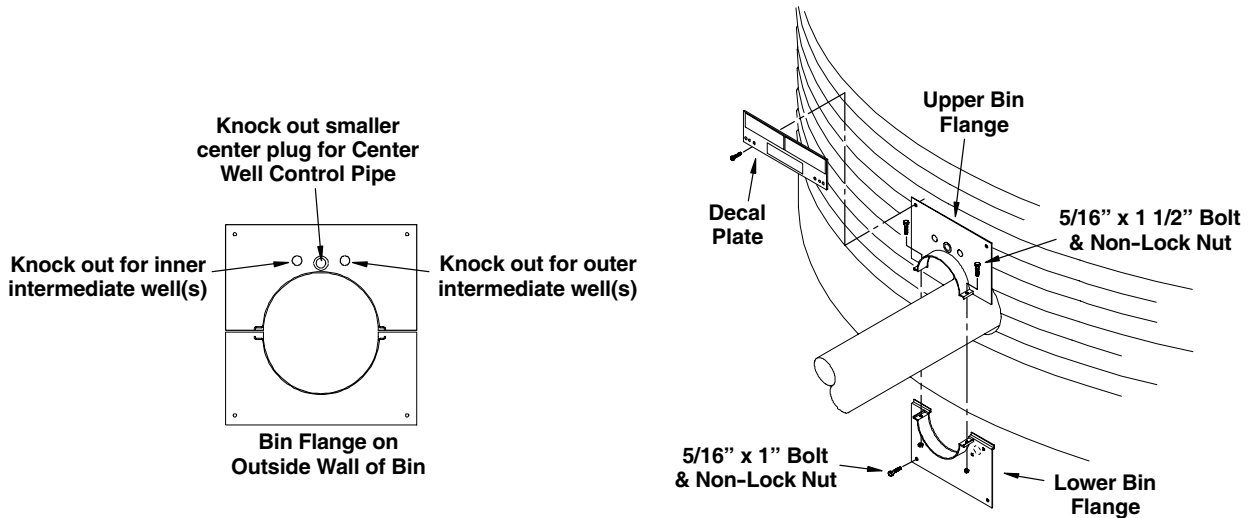

After the bin wells have been installed, the control pipes can be assembled and installed. The control pipes are installed to open and close the bin well gates. Depending on bin diameter, the number of wells will vary. It may be necessary to separate the wells into inner and outer sets of two or more so that each set is controlled by its own control pipe.

For instance, if four intermediate wells are used, the first two wells would be attached to the same control pipe and the last two wells would be attached to their own control pipe (See illustration below).

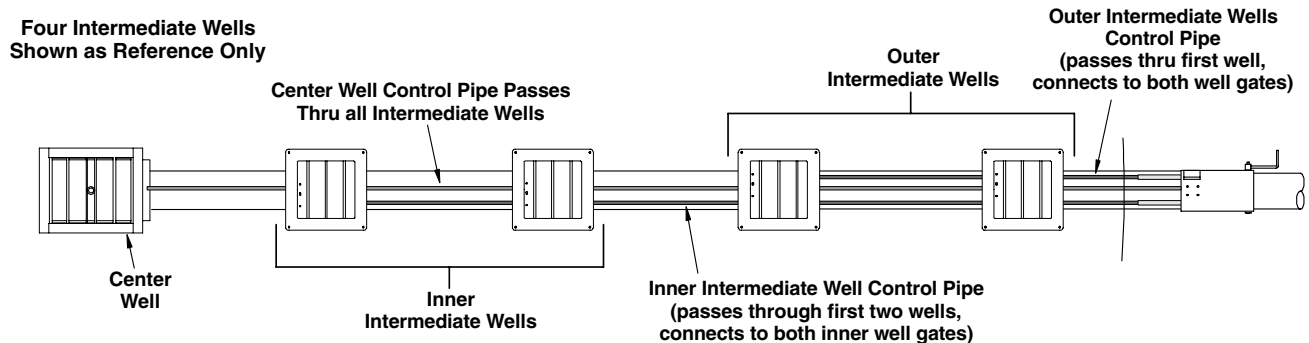

ASSEMBLY INSTRUCTIONS

BIN WELL ASSEMBLY (con't.)

Install Control Pipes Standard Bin Wells

Some sections of control pipes have a 3/8" (10 mm) dia. hole pre-drilled in one end. This control pipe is typically used for the center well gate. In applications where more than one length (section) of pipe is used, a threaded connector will be used to attach the control pipe sections together.

When attaching the control pipes to the intermediate well gates, a 3/8" (10 mm) hole will need to be drilled to accommodate the roll pin used with the gates (although two clamps are used on each well gate, the roll pin will only be used on the front clamp of the gate). Holes will also need to be drilled when attaching the control pipes to the rack and pinion controller.

Attach Control Pipe to Standard Center Well

1. Knock out the smaller hole on the front and rear side of any intermediate well located between the bin wall and center well (See Fig. 14).

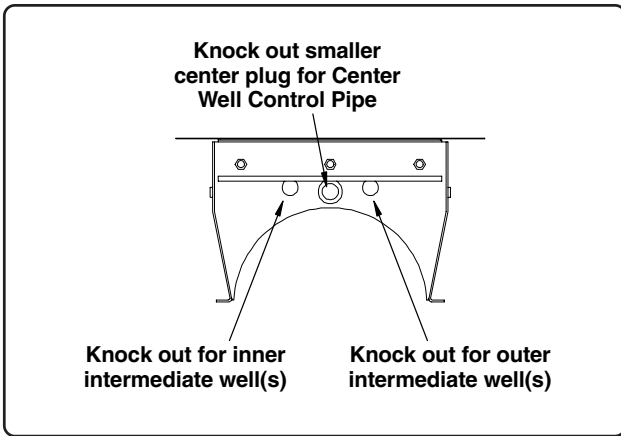

Fig. 14

2. Route the center well control pipe through the bin flange and through the intermediate well(s).
3. Position the clamp and pre-drilled end of the control rod onto the top side of gate and align the clamp with the mounting holes in the gate.
4. Insert the 5/16" x 1 3/4" roll pin through the clamp and hole in the control pipe so there is an equal amount of the roll pin extending past the sides of the clamp.
5. Secure the clamp to the gate using two 5/16" x 3/4" carriage bolts, flat washers, lock washers and non-lock nuts (insert bolts from the bottom side of the gate (See illustration below)).

The mounting hardware will be used to keep the roll pin in place.

When unloading the bin or storage structure, start unload conveyor and open center well gradually until desired flow is obtained [3" to 6" (7.6 to 15.2 cm) is usually sufficient].

When grain flow stops through the center well, leave center well gate open and begin gradually opening intermediate well gate(s) [3" to 6" (7.6 to 15.2 cm) is usually sufficient]. Begin from center of bin and work towards bin wall.

Do Not open intermediate well(s) until all flow has stopped through the center well. Plugging of the conveyor and excessive stress to the bin walls can occur, thus creating dangerous situations and possible damage to the conveyor system.

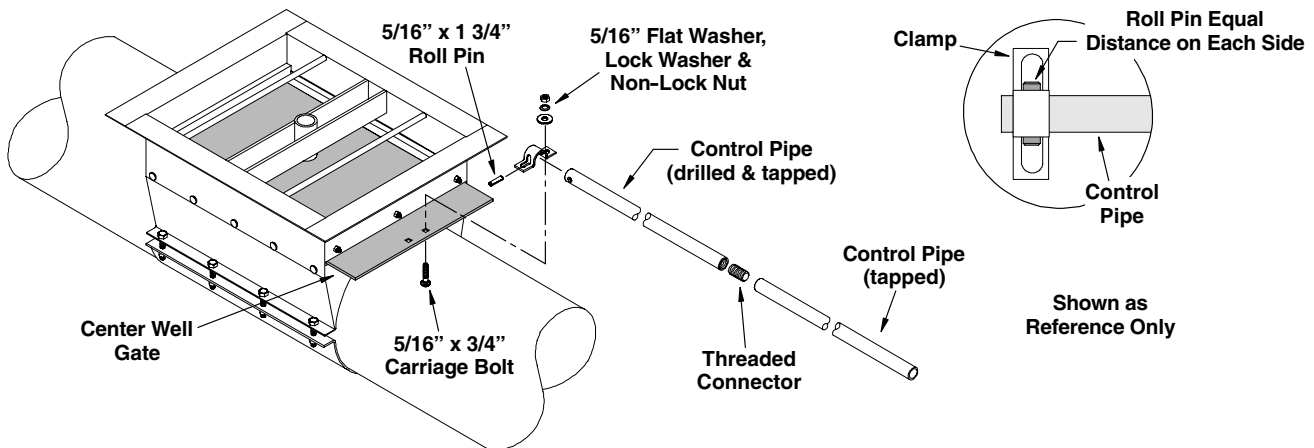

BIN WELL ASSEMBLY (con't.)

Attach Control Pipes to Standard Intermediate Wells

The intermediate well control pipes can now be attached to the well gates. Each well will use two gate clamps, one on the inside of the well and one on the outside of the well.

The slide gates in each well are shipped already slid into position, if the mounting holes for the clamps do not align with the same side the control pipe is on, simply flip the gate over to make the adjustment as shown in Fig. 16 below.

1. Punch out the appropriate knockouts in as many wells as it takes for the control pipe to reach its final well in each group (See illustration on Page 23). **Do Not punch out the rear hole in the last well of each group.**
2. From the outside of the bin wall, slide the control pipe through the bin flange and through the required number of intermediate wells it takes to get to the well farthest from the bin wall in that group.
3. Temporarily attach the end of the control pipe to the bottom side of the slide gate using one pipe clamp and two (2) 5/16" x 3/4" bolts, flat washers, lock washers and non-lock nuts (bolt heads on top).

4. With the slide gate closed, position a clamp over the control pipe at the other end of the gate.

Using the center of the slot in the clamp, make a mark onto the control pipe. This will be the drilling location for roll pin.

Loosen the clamp at the rear of the gate and pull control pipe out far enough to drill the 3/8" (10 mm) dia. hole (drill through both walls of the pipe).

Place the control pipe back into its original position. Install the pipe clamp and insert the roll pin. Attach the clamp using two 5/16" x 3/4" bolts, flat washers, lock washers and non-lock nuts (the roll pin will be captured between the bolts).

You may want to mark and drill all holes for the control pipes in each group of wells prior to assembly to allow the control pipes to be slid back for drilling. Ensure all slide gates are in the closed position before marking the drilling location.

Continue installation of the control pipes in the same manner outlined in the previous steps.

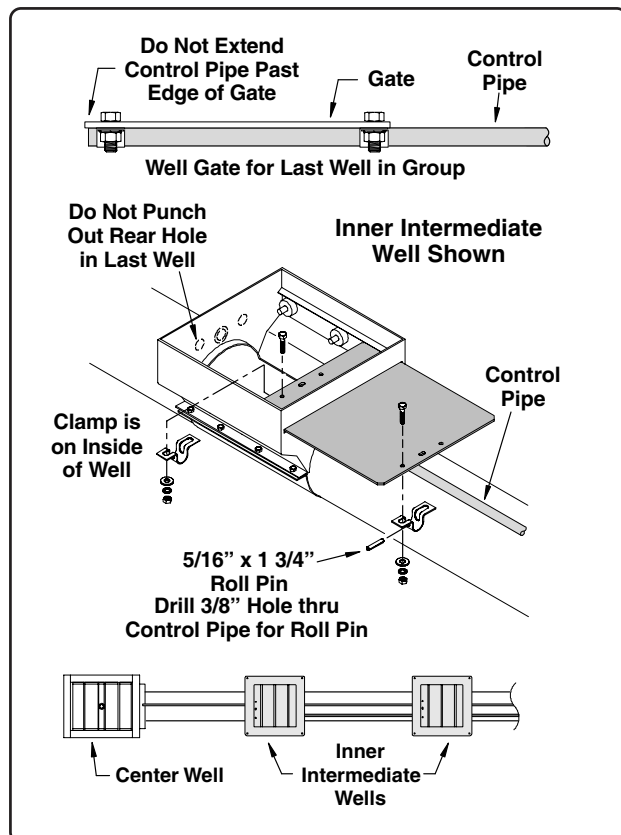

Fig. 15

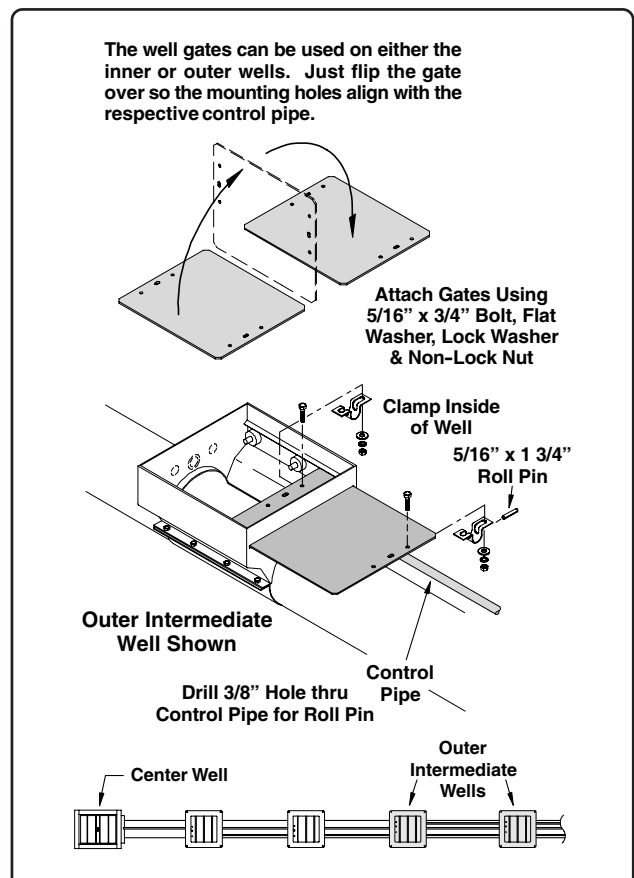

Fig. 16

ASSEMBLY INSTRUCTIONS

BIN WELL ASSEMBLY (con't.)

Install Control Pipes Commercial Bin Wells

Some sections of control pipes have a 3/8" (10 mm) dia. hole pre-drilled in one end. This control pipe is typically used for the center well gate. In applications where more than one length (section) of pipe is used, a threaded connector will be used to attach the control pipe sections together.

When attaching the control pipes to the intermediate well gates, a 3/8" (10 mm) hole will usually need to be drilled to accommodate the bolt used to attach the control pipe to the well gate. Holes will also need to be drilled when attaching the control pipes to the rack and pinion controller.

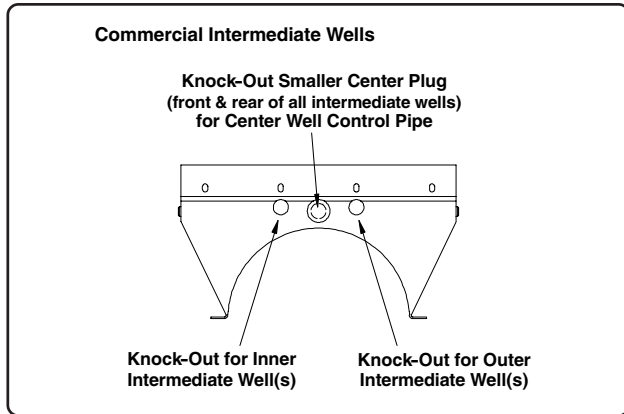

Fig. 17

Attach Control Pipe to Commercial Center Well

1. Knock out the smaller hole on the front and rear side of any intermediate well located between the bin wall and center well (See Fig. 17).
2. Route the center well control pipe through the bin flange and through the intermediate well(s).
3. Place the predrilled end of the control pipe between the angle mount tabs welded to the bottom of the center well control gate. Secure the control pipe using one (1) 5/16" x 1 3/4" bolt and nylon locknut.

When unloading the bin or storage structure, start unload conveyor and open center well gradually until desired flow is obtained [3" to 6" (7.6 to 15.2 cm) is usually sufficient].

When grain flow stops through the center well, leave center well gate open and begin gradually opening intermediate well gate(s) [3" to 6" (7.6 to 15.2 cm) is usually sufficient]. Begin from center of bin and work towards bin wall.

Do Not open intermediate well(s) until all flow has stopped through the center well. Plugging of the conveyor and excessive stress to the bin walls can occur, thus creating dangerous situations and possible damage to the conveyor system.

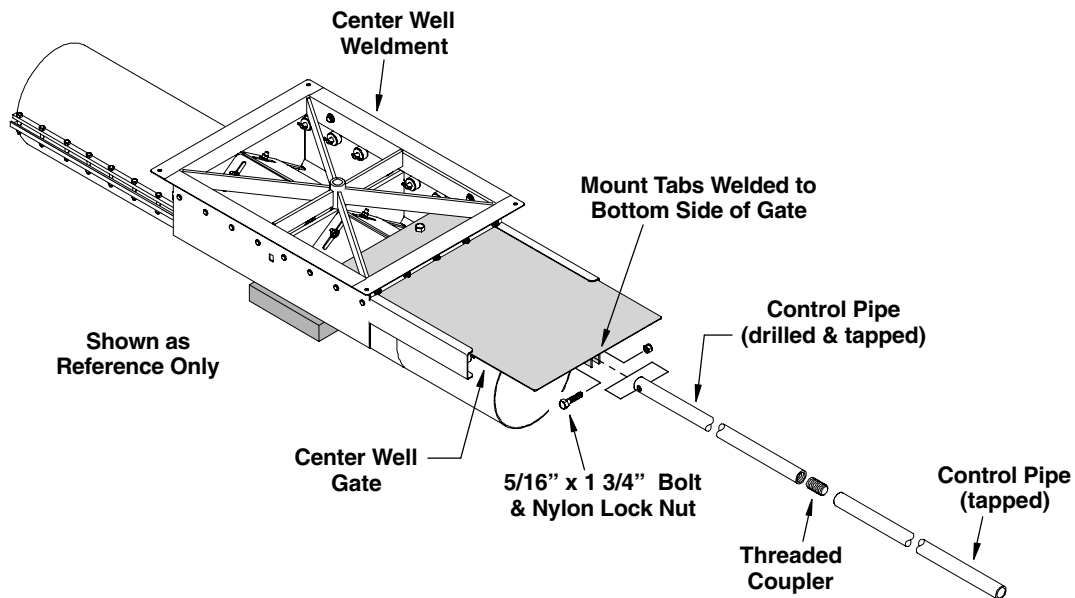

BIN WELL ASSEMBLY (con't.)

Attach Control Pipes to Commercial Intermediate Wells

The intermediate well control pipes can now be attached to the well gates. Each well will use two gate angles that will be installed onto each well gate.

The slide gates in each well are shipped already slid into position, if the mounting holes for the clamps do not align with the same side the control pipe is on, simply flip the gate over to make the adjustment as shown in Fig. 18.

1. Punch out the appropriate knockouts in as many wells as it takes for the control pipe to reach its final well in each group (See illustration on Page 23). **Do Not punch out the rear hole in the last well of each group.**
2. From the outside of the bin wall, slide the control pipe through the bin flange and through the required number of intermediate wells it takes to get to the well farthest from the bin wall in that group.
3. Install the gate angles to the bottom side of the well gates with the control pipe between the two angles. Use two (2) 5/16" x 1" carriage bolts and nylon locknuts to secure angles in place (position bolt heads on the bottom side of the gate angle).
4. Close all intermediate well gates. Using the holes in the gate angles, make a mark on the control pipes (this will be the drilling location for the bolts used to secure the control pipes to the well gates).

You may want to mark and drill all holes for the control pipes in each group of wells prior to assembly to allow the control pipes to be slid back for drilling. Ensure all slide gates are in the closed position before marking the drilling location.

Slide the control pipes back far enough to allow the holes to be drilled and drill a 3/8" (10 mm) dia. hole at each of the marked locations.

Secure the control pipes to the gate angles using one (1) 5/16" x 1 3/4" bolt and nylon locknut.

Continue installation of the control pipes in the same manner outlined in the previous steps.

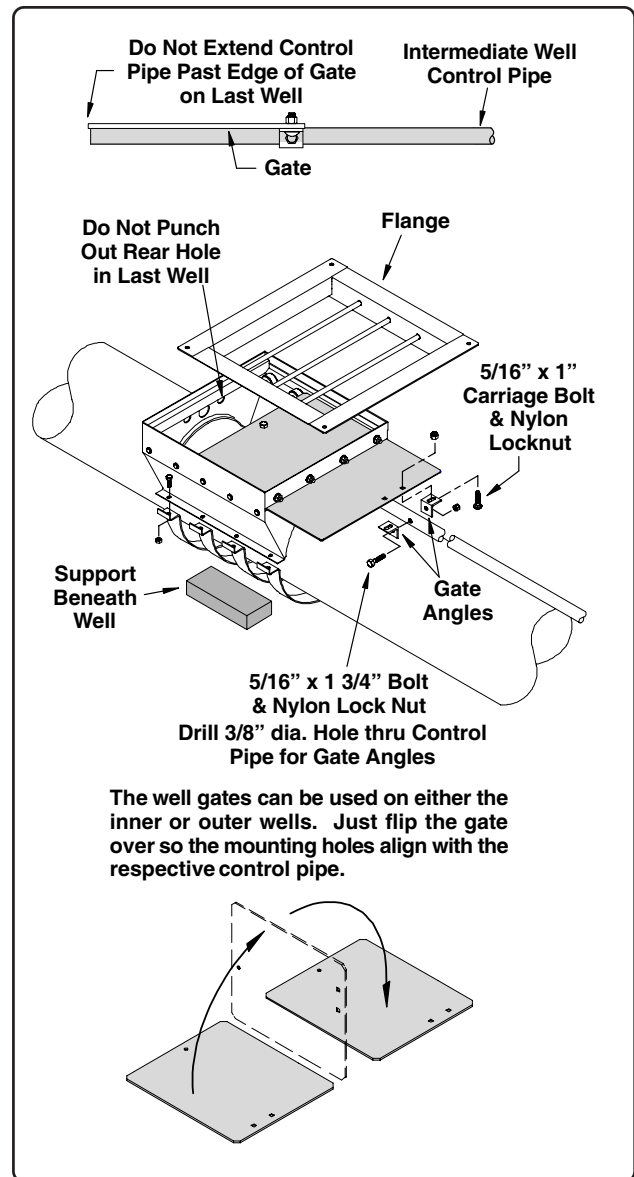

Fig. 18

STANDARD RACK & PINION INSTALLATION

The Rack & Pinion Control was designed to aid in the opening and closing of the bin well control gates. The device is set up for operating up to three sets of control pipes. The center sleeve operates the control pipe for the center bin well, and the two outside sleeves operate the control pipes for the intermediate wells (up to three wells can be operated with each of the outside controls sleeves).

1. Make sure all the bin well control gates are in the closed position.

Crank the handle on the rack and pinion unit so the control sleeves pull back into the housing. With the control sleeves facing the bin wall, position the unit onto the unloading tube near the flange end.

Turn the handle so the control sleeves extend out as far as possible (the holes drilled through the sleeves will be used to attach the control rods from the bin well gates, the control rods should be measured and cut so they extend at least 1-1/4" past these holes, See illustration below).

2. With the bin well gates completely closed and the controls sleeves fully extended, determine how long each of the bin well control pipes need to be when extended 1-1/4" past the holes in the control sleeves.

Cut the control rods to length and reposition the rack and pinion unit onto the loading tube. Insert the control pipes into their appropriate sleeves while sliding the unit onto the pipes until the ends of the pipes reach that 1-1/4" mark.

Secure the rack & pinion unit to the unloading tube using two half bands and eight 5/16" x 1" bolts and non-lock nuts.

3. Using the holes in the control sleeves as a template, drill a 3/8" dia. hole through each of the control pipes. The bin well control pipes can then be attached to the control sleeves with either a snap pin or a bolt and nut.

To operate only the center bin well gate, remove the pins (or bolts) from the two outside control sleeves leaving the center sleeve attached to the center bin well control pipe.

To operate only the intermediate bin well gates, remove the pin (or bolt) from the center control sleeve.

4. Check that all well gates open and close freely, and make sure they close completely when the control sleeves are fully extended.

IMPORTANT!

Make sure all bin wells are closed before filling bin with grain.

Start unloading conveyor before opening gates.

Close all bin well gates before stopping the unload conveyor.

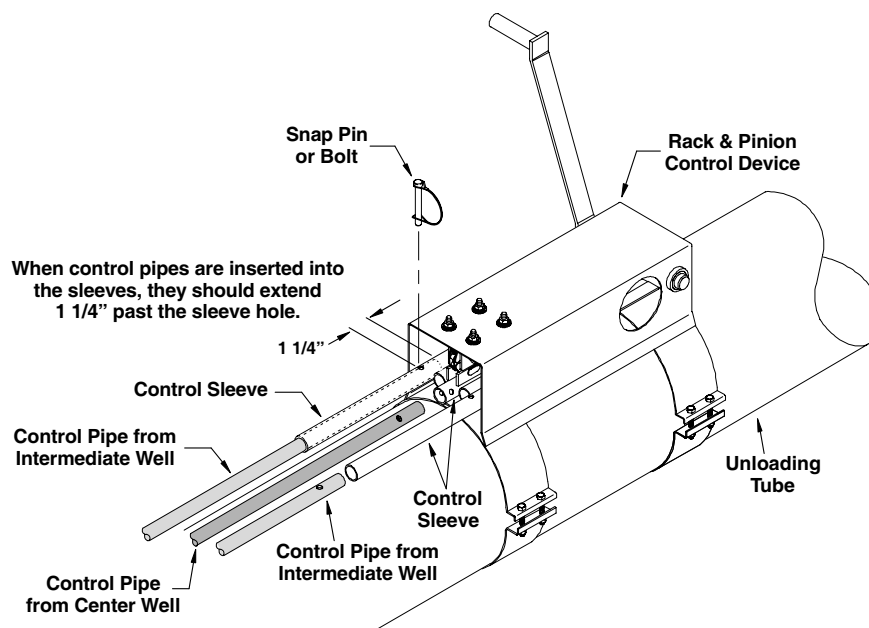

COMMERCIAL RACK & PINION INSTALLATION

The Rack & Pinion Control was designed to aid in the opening and closing of the bin well control gates. The device is set-up for operating up to three sets of control pipes. The center sleeve operates the control pipe for the center bin well, the two outside sleeves operate the control pipes for the intermediate bin wells.

An electric operated Rack & Pinion Controller is also available. The installation of the controller is the same as the manually operated one shown below. The instructions for the electric motor connection are included with the motor and will require installation by a qualified electrician.

1. Make sure all bin well gates are in the closed position. Loosely attach the rack & pinion base plate to the unload auger tube on the outside of the bin wall. Use 5/16" x 1 1/4" bolts and nylon locknuts to secure the half-bands to the base plate.
2. Crank the handles on the rack & pinion so the control sleeves pull back into the assembly. Position the rack & pinion control assembly onto the base plate and secure using ten (10) 1/2" x 1 1/4" bolts, flat washers and nylon locknuts (See illustration below).
3. Crank the handles so the control sleeves extend out as far as possible. With the bin well gates completely closed and the control sleeves fully extended, determine how long each of the bin well control pipes need to be so that the ends of the pipes will extend approximately 1 1/4" past the holes in the control sleeves (See illustration below).

Cut the control pipes to length and reposition the rack & pinion unit on the unload tube. Insert the control pipes into their appropriate sleeves and slide the unit onto the pipes until the ends of the pipe reach that 1 1/4" mark. Secure the half-bands on the rack & pinion base plate to the unload tube to hold controller in position.

4. Using the holes in the control sleeves as a template, drill a 3/8" (10 mm) dia. hole through each of the control pipes and secure each pipe to the sleeve using one (1) 5/16" x 1 3/4" bolt and nylon locknut.

To operate only the center well gate, crank the handle in the desired direction (See illustration below).

To operate the intermediate well gates, remove the bolt from one of the control sleeves to open or close the desired group of well gates (inner or outer group).

Check that all gates open and close freely, and that all gates close completely.

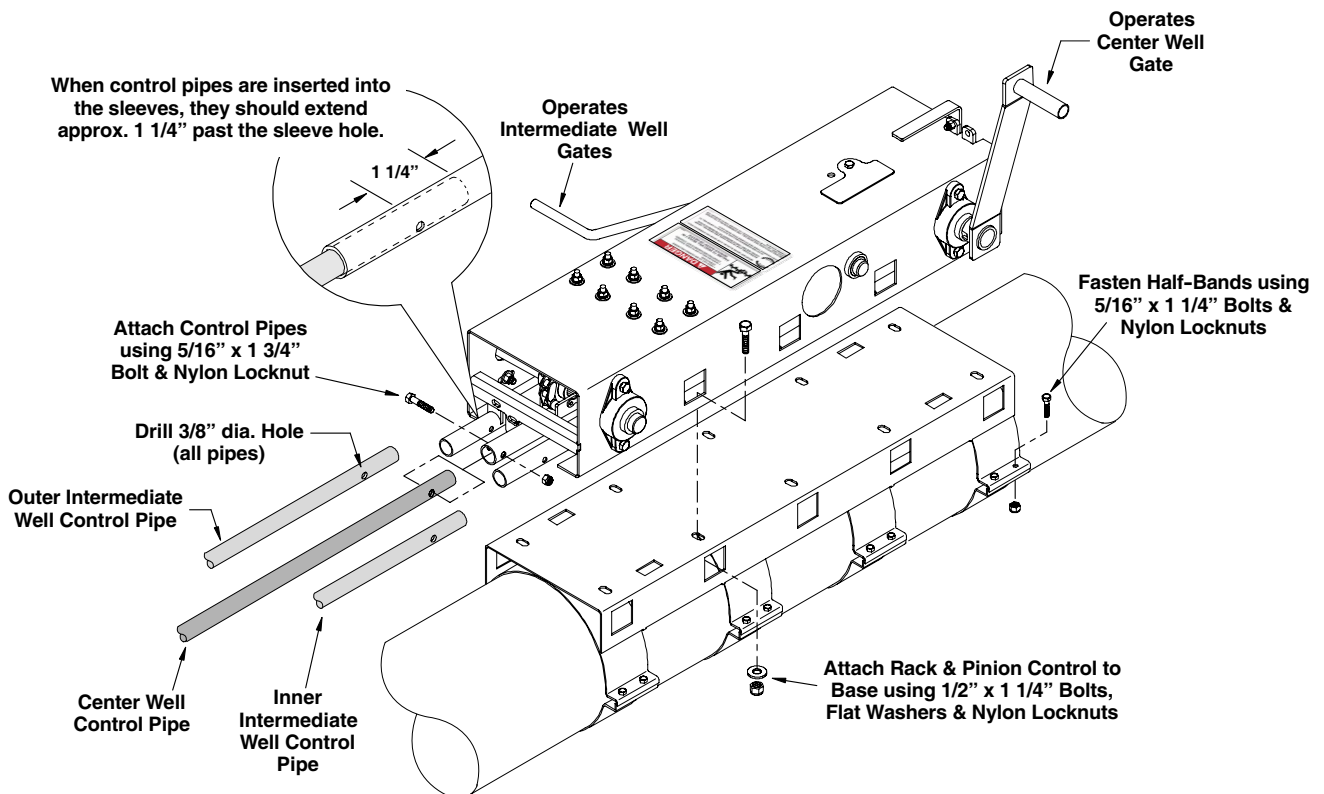

ASSEMBLY INSTRUCTIONS

INLET DUMP HOPPER INSTALLATION

The dump hopper will include conveyor tubing from 8' to 15'-4" depending on the length of the dump hopper selected. It will also include either a top safety screen or drive over grating depending on your application.

There is a grain flow control inside the hopper that is adjustable using chains mounted at each end. There is also a dump hopper available that has a control gate operated by an electric motor. The instructions for the electric motor connection are included with the motor and requires installation by a qualified electrician.

A dump hopper is to receive grain into the Grain Pump® Loop System and should be located at a point along the bottom conveyor portion. Usually the dump hoppers are located near the standard corner where the chain and paddles turn to carry grain up into the system (See illustration below).

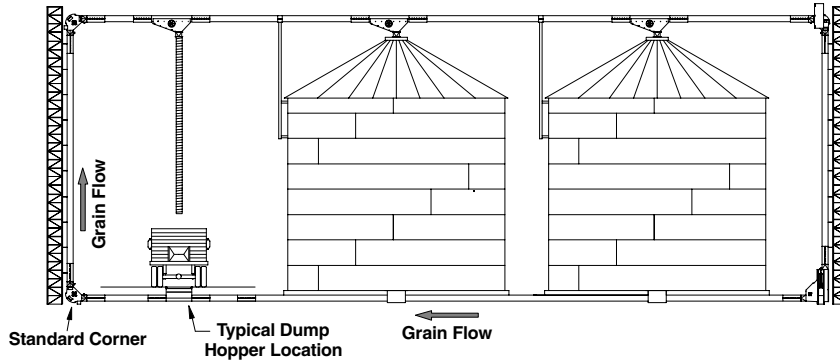

A hopper with top safety screen may be used in non-drive over situations (the top safety screen **will not** support vehicles). Make sure either the top safety screen or drive over grating is in place on the hopper at all times.

For drive-over systems the grate must be supported by a concrete structure, such as shown below. Even if the dump hopper is not used for a drive-over system, it will still need some type of support structure.

Once the location of the dump hopper has been determined and properly installed, attach the hopper to the loop system conveyor tubes using the connecting bands provided.

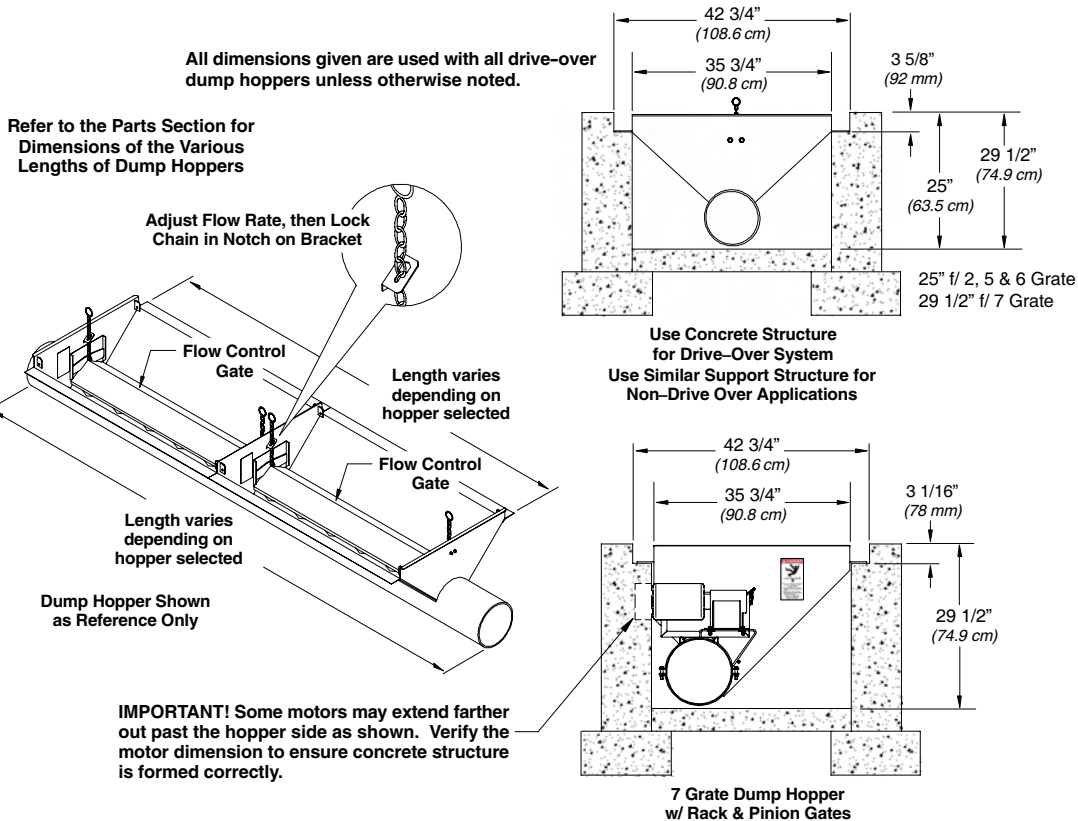

INSPECTION CORNER INSTALLATION **(MANUAL TAKE-UP)**



CAUTION! Do Not operate the conveyor when the inspection door or access doors are open.

After the location for the inspection corner assembly has been determined, attach the upper and lower flanged tube sections to the inspection corner using 3/8" x 1" bolts and nylon locknuts.

Secure the flange tubes to conveyor tubing using the connecting bands and 3/8" x 1 1/2" bolts and nylon locknuts provided.

When cutting tubes to exact length, the ends must be cut square and any burrs on the ends removed (make sure the tube ends are tight against each other when installing connecting bands).

1. Remove the inspection door on the rear of the corner assembly and the access door on the front as well (this will give you access when running the chain and paddle sections through the loop system).

The inspection door, as well as the access doors can be used to check chain tension whenever it is necessary. **Do Not operate the conveyor with the inspection or access doors open.**

To check chain tension, grasp one of the paddles and attempt to rotate it towards the chain. Proper tension should only allow minimal movement of the paddle. Another indication of proper chain tension is whether the traction wheel shaft is turning while the loop system is running. **See Page 10 in the Maintenance Section for information on this procedure.**

2. When chain tension requires adjustment, remove the inspection door from the rear of the inspection corner assembly. Loosen the jam nuts securing the adjustment bolts at the top of the housing.

Turn each adjustment bolt in equal increments until desired chain tension has been achieved.

If the chain is still too loose after the inspection corner sprocket has been adjusted to the full down position, it may be necessary to remove one or more links from the chain.

When adjustment of chain tension is complete, tighten jam nuts to lock bearing slides & sprocket into place.

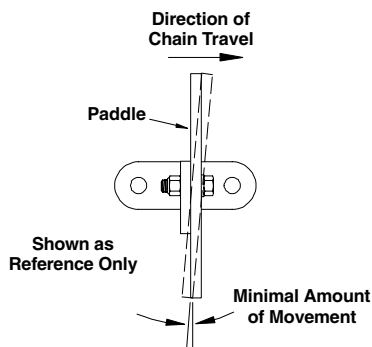
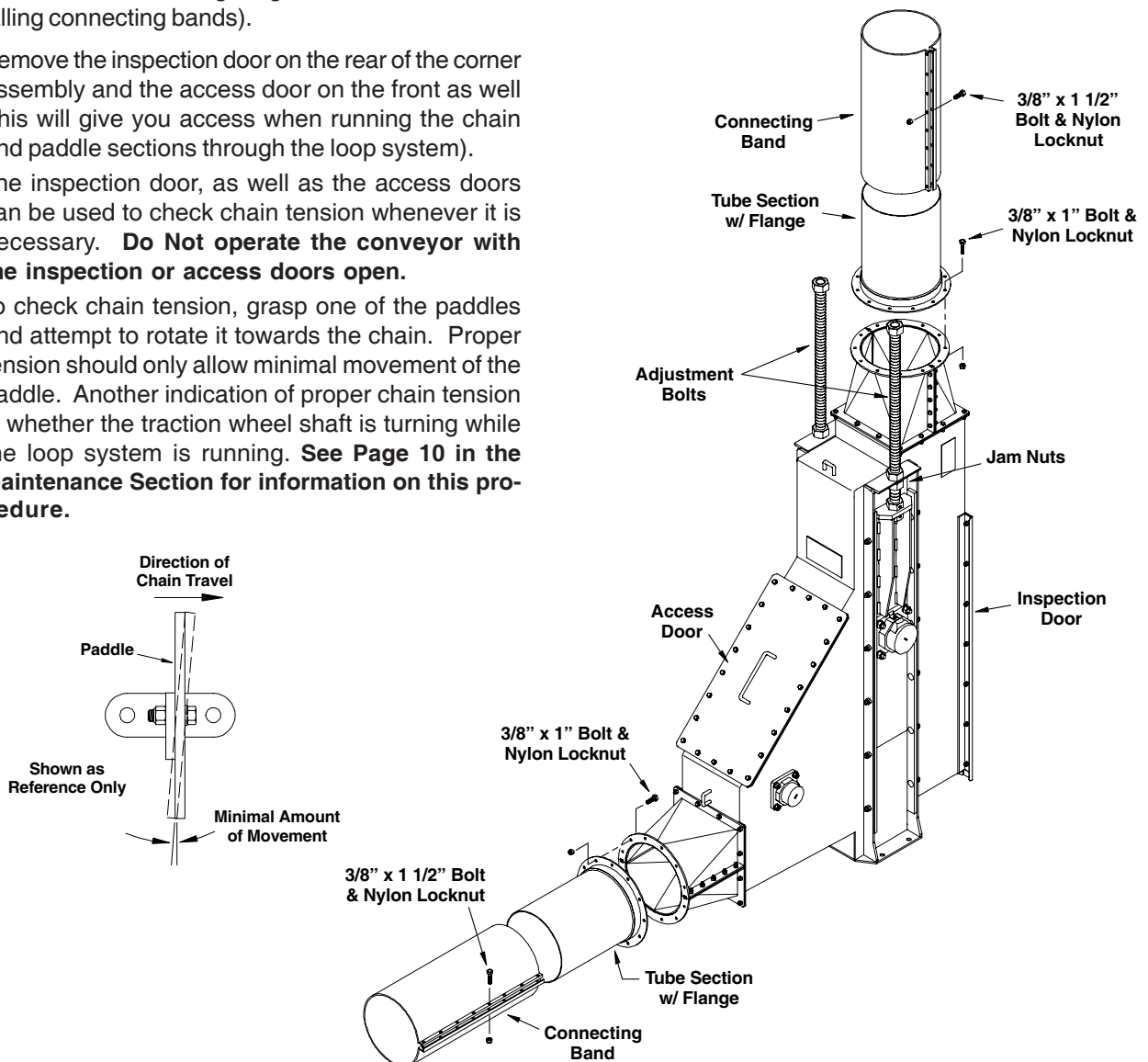

ASSEMBLY INSTRUCTIONS

AUTO TAKE-UP CORNER ASSEMBLY (STANDARD)



CAUTION! Do Not operate the conveyor when the inspection door or access doors are open. Make sure the lock-out pin is in place when the carriage is in its full raised position.

After the location for the inspection corner assembly has been determined, attach the flanged tube sections to the inspection corner using 3/8" x 1" bolts and nylon locknuts. Secure the flanged tubes to the conveyor tubing using the connecting bands and 3/8" x 1 1/2" bolts and nylon locknuts provided (See illustration below).

1. Install the winch onto the mounting bracket located on the inside face of the corner assembly. Secure the winch using three (3) 3/8" x 1" bolts, two (2) flat washers and nylon locknuts. Attach the winch handle to the winch.
2. Mount the weights onto the auto take-up carriage. Place a single weight on one side, then another weight on the opposite side. Repeat until all eight weights have been placed onto the carriage. To keep the weights from sliding off, install a 3/8" x 1 1/2" bolt and nylon locknut onto each end of the take-up carriage.
3. Fasten the pulley bracket onto the vertical tube above the auto take-up weights as shown below. Position the pulley bracket approximately 34" (86.4 cm) above the flanged tubing's connecting point. Secure the bracket to the tube using one half-band and six (6) 3/8" x 1 1/2" bolts and non-lock nuts.
4. Assemble the pulley using the provided pulley wheel, side plates, bushing and 1/2" x 2" bolt and nylon locknut. Hang the pulley assembly from the pulley bracket mount tabs and secure with one (1) 1/2" x 2 1/2" bolt and nylon locknut.

5. Attach the lift cable to the winch drum as shown below. Wind the cable onto the drum so that the cable wraps around the drum three times (cable should wrap from the bottom of the drum when the handle is turned in a clockwise direction).

Secure cable to side of drum using the cable keeper as shown below.

6. Route the loose end of the cable up and around the pulley previously installed. Attach the cable hook to the end of the cable and secure hook using the two cable clamps provided (make sure the u-bolt portion of the clamps are against the loose end of the cable).
7. Connect the hook to the top of the take-up carriage. Check that the take-up carriage travels through its entire range of motion as the winch is being operated (when the carriage is in its full raised position, a lockout pin will be inserted through the slide plate to support the carriage whenever servicing the unit is required).

IMPORTANT! When the weights and take-up carriage are in the full down position, there needs to be some slack in the winch cable. This allows the tension sprocket to provide proper pressure on the chain. Refer to Page 10 for chain tension procedures.

Insert 3/16" x 3/4" Carriage Bolts from Inside of Winch Drum

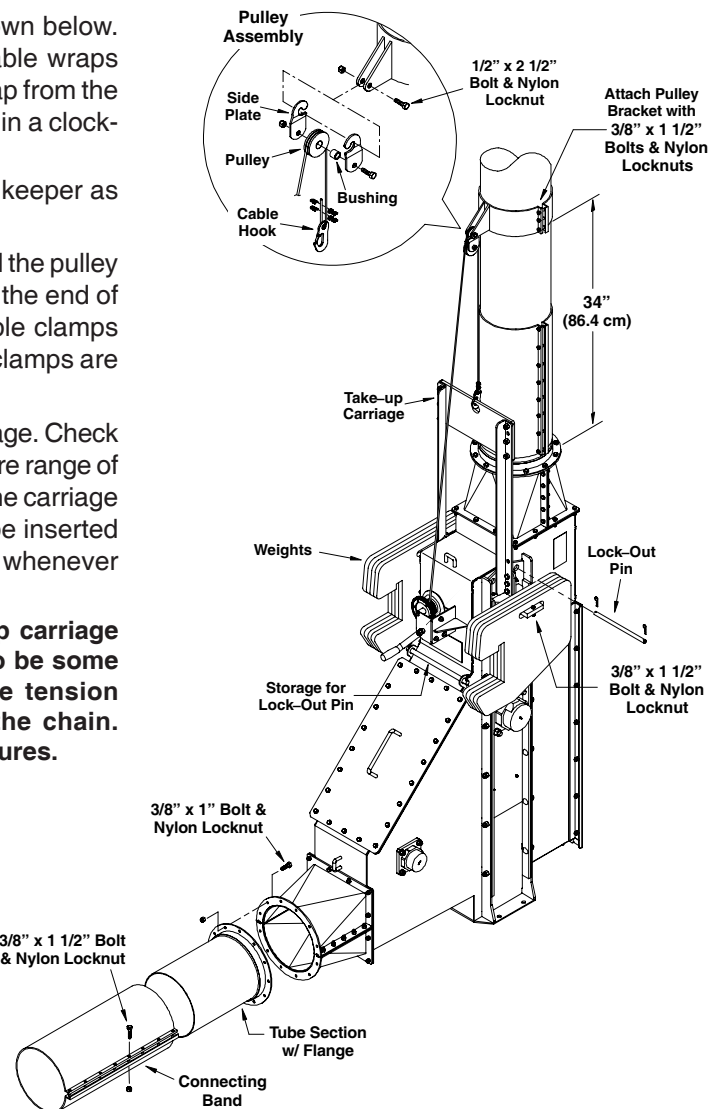
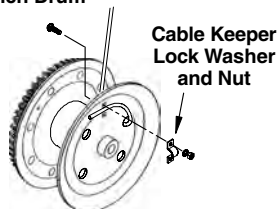

DRIVE CORNER



WARNING! Whenever you must service or adjust the equipment, make sure to stop the motor and lock-out the power source.



A main disconnect switch capable of being locked in only the “Off” position shall be used. This shall be locked whenever work is being done to the conveyor.

The Commercial Grain Pump® Loop System is powered by an electric motor. Always use a motor with required horsepower (*kw*) as calculated on Page 7. Use a 60 hz motor that operates at 1750 RPM (50 hz @ 1460 RPM). Also see “Electric Motor Drive Information” and Lockout procedures on Pages 8 & 9 in this manual.

Electrical motors and controls must be installed by a qualified electrician and must meet the standards set by the National Electrical Code and all state and local codes.

IMPORTANT! Use the motor sheave that is furnished with the conveyor system. If a different size sheave is used or substituted, improper chain speed will result causing unsatisfactory conveyor operation.

Use the proper size and speed motor to ensure the conveyor operates effectively and efficiently. Too small a motor will not supply the horsepower (*kw*) required to achieve capacity and possible damage to the motor can occur.

Too large of a motor may cause high stress on conveyor components resulting in shorter life for these components. Refer to Page 7 for information on calculating correct motor size.

1. Install the cooling fan (if provided) to the reducer shaft using the instructions provided with the cooling fan.
2. Mount the belt guard according to the instructions provided with the belt guard and drive components. When mounting the sheaves to either the motor shaft or reducer shaft do the following:

Install the bushing onto the shaft first, then slide the sheave onto the bushing (the bushing will be on the inside).

Install the driven sheave as close to the back of the belt guard as possible. Align sheaves by using a straight edge placed across the face of both sheaves. Secure sheaves into place.

Install the drive belts to the sheaves and set belt tension. To tighten belts, turn the 3/4” nuts on the motor mount bolts until belt tension has been achieved (proper belt tension is approx. 1/2” (13mm) of deflection when belts are firmly pressed in the center of the span between the two sheaves).

3. Attach the flanged tube sections to the drive corner using 3/8” x 1” bolts and nylon locknuts. Connect the drive corner and flange tubes to the conveyor tubes using the connecting bands and 3/8” x 1 1/2” bolts and nylon locknuts provided.

IMPORTANT! The gear reducer is shipped without oil. It is necessary to add oil before unit operation. Refer to Page 13 for procedures on adding oil and the proper grade of oil to be used.

Typical Drive Corner Assembly

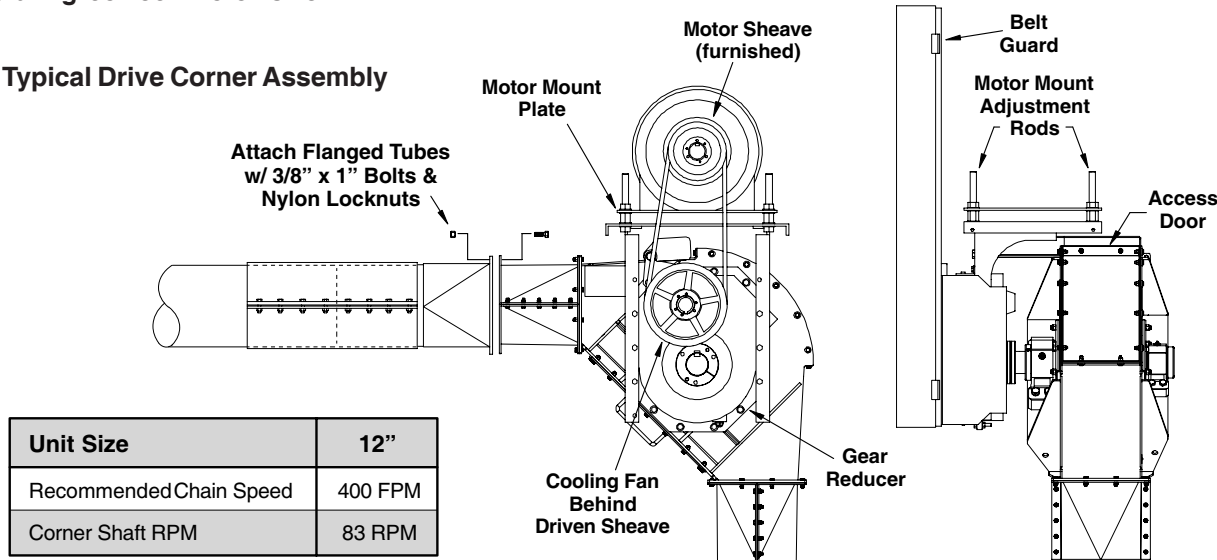

Unit Size	12”
Recommended Chain Speed	400 FPM
Corner Shaft RPM	83 RPM

CONVEYOR CHAIN & PADDLE**ASSEMBLY**

CAUTION! The areas around the chain sprockets can create pinch points causing personal injury. Use caution when working around these areas.



The take-up carriage is provided with a lock-out pin. To avoid serious injury, **Do Not attempt to access or service the chain, paddles or other parts within the inspection corner without the lock-out pin in place.**

Note: Some units may be shipped with the paddles already attached to the chain. If your unit already has the paddles attached, continue with Step 2 below.

If the paddles have not been installed, begin with Step 1 below.

1. Install the paddles so that the paddle mounting brackets are behind the paddles as grain is being moved through the conveyor tubes.

For single strand 81XHH chain, attach each paddle to the mounting brackets with two (2) 5/16" x 1 1/2" bolts, two (2) flat washers (on paddle side) and two (2) nylon locknuts (See illustration on following page, Page 37). Make sure a paddle is attached to every mounting bracket along the length of the chain.

For double 81XHH chain, attach the paddles to the chain brackets using two (2) 5/16" x 1 1/2" bolts, flat washers (on paddle side) and nylon locknuts (See illustration on Page 37).

There is an optional rubber clean-out that can be used with the double-chain and paddles. Attach the clean-out to the paddle using two (2) 5/16" x 1 3/4" bolts, four (4) flat washers and nylon locknuts, secure clean-out to the paddle and chain bracket using two (2) 5/16" x 1 3/4" bolts, two (2) flat washers (on paddle side) and nylon locknuts (See illustration on Page 37).

2. It will be necessary to use an electrical fish tape, wire, or rope to pull the chain through the conveyor tube sections. It is recommended to begin and end at the take-up inspection corner, as this will be where the chain's tension will be determined. Using the winch, raise the take-up carriage and weights high enough to **insert the lock-out pin** through the slide plates to support the raised carriage (for manual take-up corner, use the adjustment bolts to raise sprocket high enough to allow clearance for chain assembly).

IMPORTANT! On long horizontal runs it is possible for the chain to rotate 360° during the pull-through between corners. Use inspection doors discharge gates and openings in bin wells to observe the chain position along the length of the conveyor sections.

After the chain and paddles have been installed through the conveyor housing and around all corner sprockets, connect the ends of the chains together at the take-up inspection corner using the connecting link and cotter pins provided.

Once the chain ends have been connected together, slowly lower the take-up carriage aligning the sprocket and the chain. Continue lowering the carriage until sprocket is down as far as it can go.

For **auto take-up** corners, the full weight of the carriage will be resting on the chain and there should be a bit of slack in the winch lift cable (**if the lift cable is tight during operation, proper chain tension will not be maintained**).

To check chain tension, grasp one of the paddles and attempt to rotate it towards the chain. Proper tension should allow only minimal movement of the paddle.

If there is more movement than recommended and all weight is resting on the chain, it may be necessary to remove more links from the chain (**if less tension is desired, remove weights in pairs, one from each side until desired tension is achieved**).

For **manual take-up** corners, use the adjustment bolts to achieve proper chain tension. Check chain tension as stated above.

Another indication of **proper chain tension** is whether the traction wheel shaft is turning while the loop system is running. **See Page 10 in the Maintenance Section for information on this procedure.**

CONVEYOR CHAIN & PADDLE ASSEMBLY (con't.)

Single Strand 81XHH Chain & Paddles

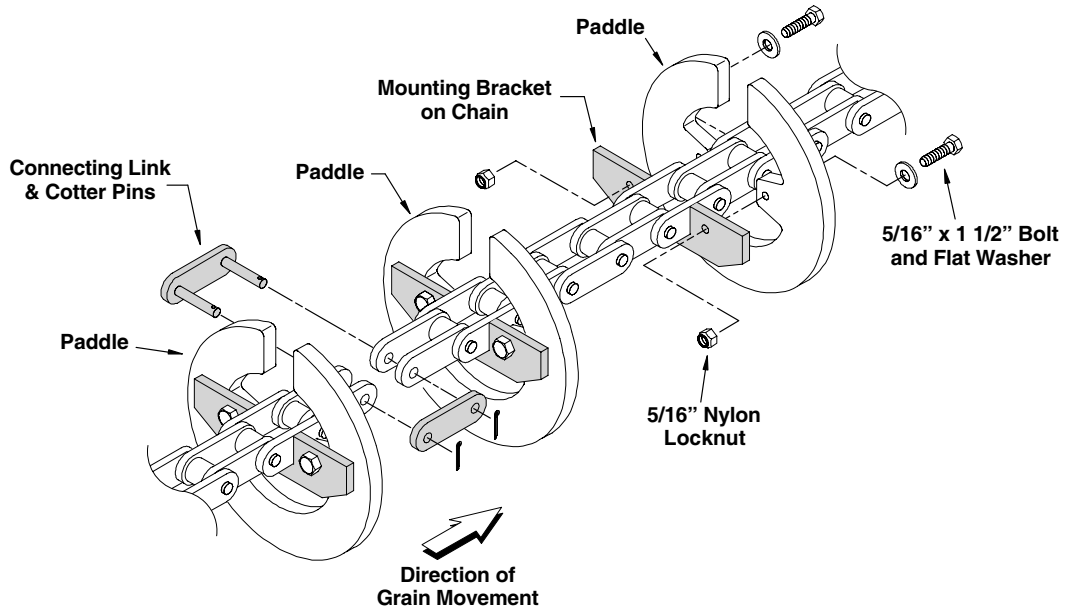

Double Strand 81XHH Chain & Paddles

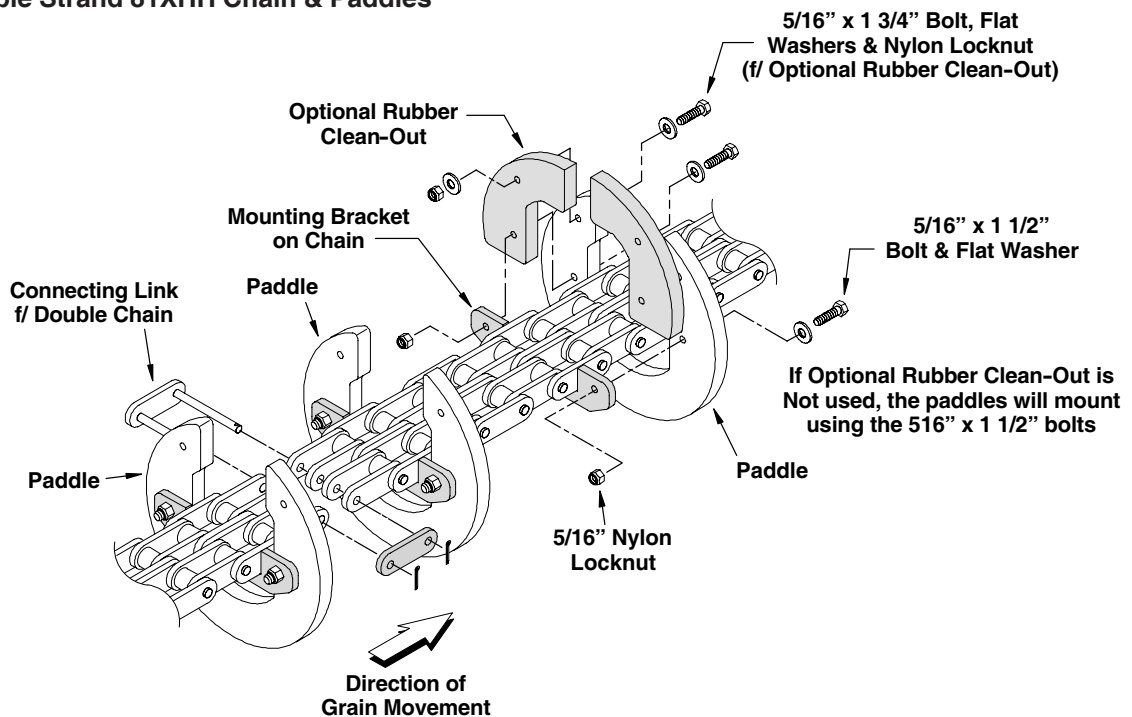

ASSEMBLY INSTRUCTIONS

DISCHARGE SPOUT with CABLE GROUND CONTROL GATES



CAUTION! Metal parts may have sharp edges and can create flying debris when filed, cut or drilled. Use proper safety equipment such as gloves, eye protection and hearing protection when working with metal materials.



Use caution when working in areas above the ground. Use fall protection equipment and follow applicable OSHA guidelines and regulations.



Metal buildings, scaffolding and other types of work surfaces can become slippery, especially when surfaces are wet and/or oily. This can create hazardous working conditions. Use caution when working, climbing or walking on these surfaces.

The location of the discharge controls and routing of the control cables (or ropes) should have been determined before ordering the Grain Pump® Loop System.

The discharge gate controls must be located in line with the conveyor tube so the control cable, or rope will track properly on the control wheels.

The cable, or rope should be one continuous length. If splicing is necessary, splice the ends together with cable clamps. Plan where the splice(s) in the control cable, or rope are to be located. Avoid splicing where the splice will be pulled onto a control wheel or through a pulley while the gate is being opened or closed.

The wall brackets are designed to be mounted directly to the grain bin wall. Locate the control wheel about 5' off the ground (or at a height that is easy and convenient to reach). Locate the upper wall bracket (with pulleys) at the top of the bin wall so the control cable, or rope will clear the eave of the roof or other hanging structures.

The ground control wheel can be mounted to the same bin that the discharge spout is attached to (See Example 1), or the ground control wheel can be mounted to an adjacent bin (Example 2).

Refer to the following page, Page 39, for assembly procedures of the wall brackets, pulleys and cable control wheels.

The control cable, or rope must be anchored to both the upper and lower wheels to provide positive control and to prevent the cable or rope, from slipping on the control wheels.

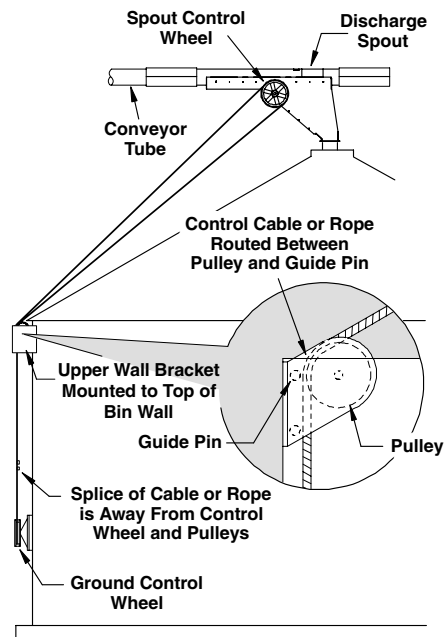

Example 1
Controls Mounted on Bin
Where Spout is Located
(pulley mounted on inside of bracket)

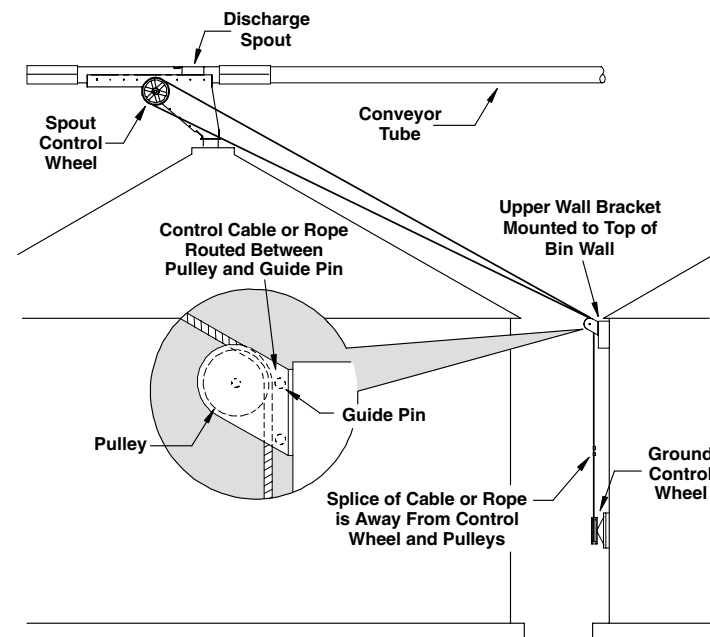

Example 2
Controls Mounted
on Adjacent Bin
(pulley mounted on outside of bracket)

DISCHARGE SPOUT with CABLE
GROUND CONTROL GATES (con't.)

The upper wall bracket and the ground control wall plate are designed to be mounted directly to the grain bin wall. Use the existing hardware from bin wall to fasten the bracket and plate to the bin.

1. Attach the two pulleys to the upper wall bracket using four (4) 1/4" x 3/4" bolts and nylon locknuts for each pulley. **Note: Mount the pulleys so both of them are either on the inside or on the outside of the wall bracket.**
 - A. If the controls are mounted on the same bin that the discharge spout is attached to, mount the pulleys on the inside of the wall bracket (See Example 1 on Page 38 and illustration below).
 - B. If the controls are mounted to an adjacent bin, mount the pulleys on the outside of the wall bracket (See Example 2 on Page 38 and the illustration below).
2. Locate the wall bracket and pulleys so they are in line with the discharge spout control wheel (this will allow the cable, or rope to properly track onto the spout control wheel). Attach the wall bracket to the top of the bin wall in a position that allows the cable, or rope to clear the eave of the bin.

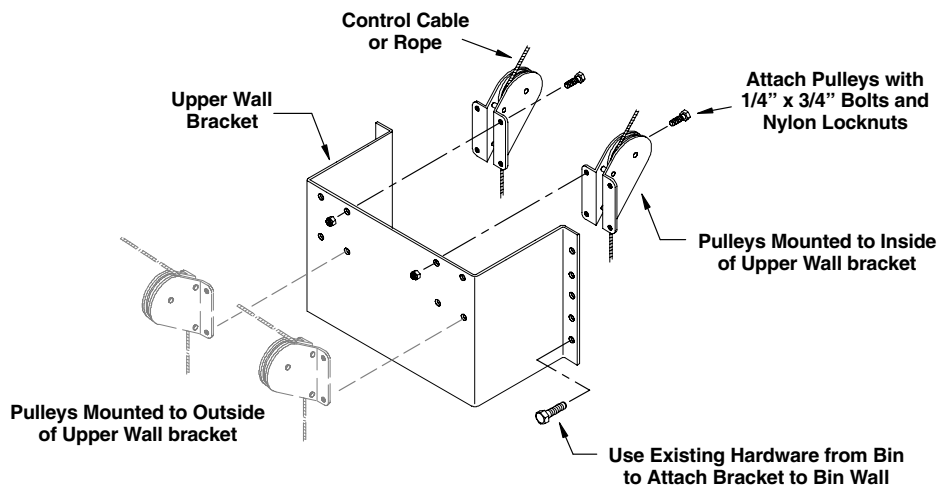

3. Attach each wall plate to the wheel bracket as shown below. Secure the brackets using two (2) 3/8" x 1" bolts, four (4) flat washers, and two (2) nylon locknuts (be sure to use a flat washer over each slot). Slide the wheel bracket up so the bolts are at the bottom of the wheel bracket slots, but at the top of the wall plate slots.
4. Determine the location of the ground control wheel and attach the wall plates to the bin wall (use the existing hardware from the bin to mount the plates).
5. Slide a 1" flat washer over the shaft on the wheel bracket and install the control wheel. Slide another 1" flat washer onto the shaft and secure using a 3/16" x 1 3/4" cotter pin.

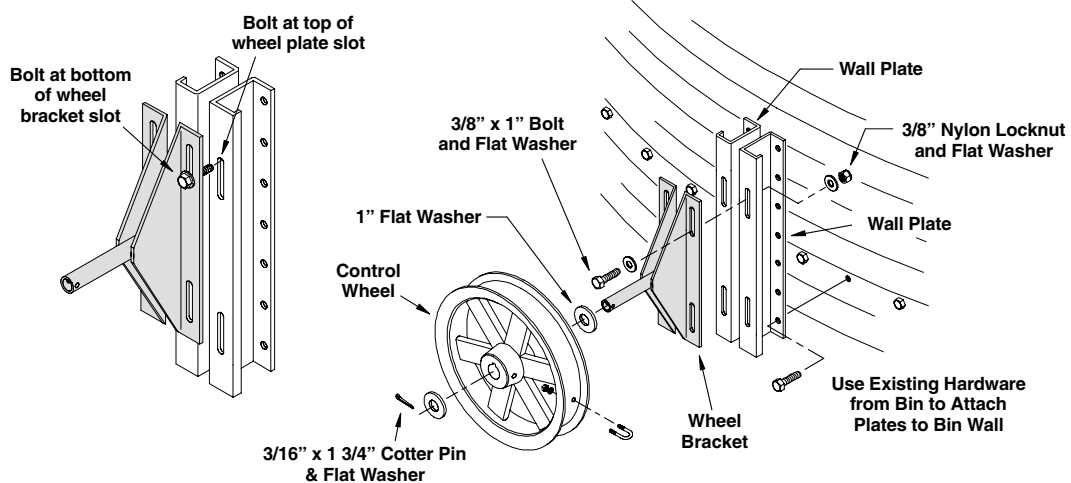

ASSEMBLY INSTRUCTIONS

DISCHARGE SPOUT with CHAIN **GROUND CONTROL GATES**



CAUTION! Metal parts may have sharp edges and can create flying debris when filed, cut or drilled. Use proper safety equipment such as gloves, eye protection and hearing protection when working with metal materials.



Use caution when working in areas above the ground. Persons working on equipment that requires above ground work shall be properly secured with the use of “fall protection” equipment as set forth by OSHA guidelines and regulations.



Metal buildings, scaffolding and other types of work surfaces can become slippery, especially when surfaces are wet and/or oily. This can create hazardous working conditions. Use caution when climbing, walking or working on these of surfaces.

The location of the discharge controls and routing of the control chains should have been determined before ordering the Grain Pump® Loop System.

The discharge gate controls must be located in-line with the conveyor tube so that the control chain will track properly on the control sprockets.

The chain should be one continuous length having only one splice. Plan where the splice(s) in the chain will be located (**the splice needs to be located so it cannot be pulled onto the sprocket wheel or through a roller and pulley**).

Although a chain is furnished with the kit, it does not mean the length provided will be long enough for your application. If additional chain is needed and requires more than one splice, make sure to locate the additional splice in the same manner.

The upper wall bracket and the ground control wall plate were designed to be mounted directly to the grain bin wall. Use the existing hardware from the bin wall to attach the bracket and plate to the bin.

The lower chain mount can be mounted to the same bin that the discharge spout is attached to, or it can be mounted to an adjacent bin (See Examples 3 & 4 below). Whichever method is used, both rollers need to be mounted either on the inside or on the outside of the wall bracket.

Locate the lower chain mount about 2' to 3' (61.0 cm to 61.4 cm) off the ground (or at a height that is easy and convenient in order to reach the chain above the lower chain mount).

Locate the upper wall bracket (with rollers) at the top of the bin wall so the control chain will clear the eave of the roof or other hanging structures.

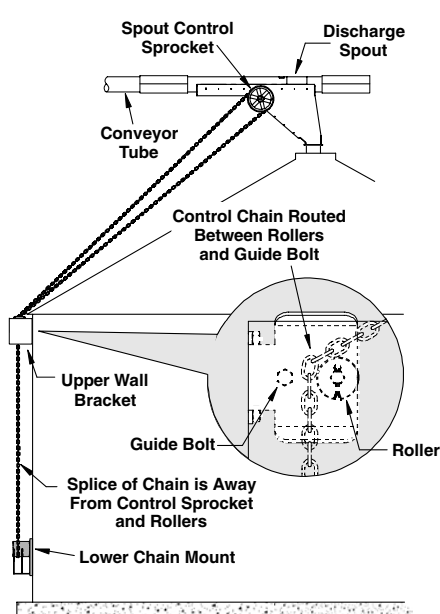

Example 3
Controls Mounted on Bin
Where Spout is Located
(rollers mounted on inside of bracket)

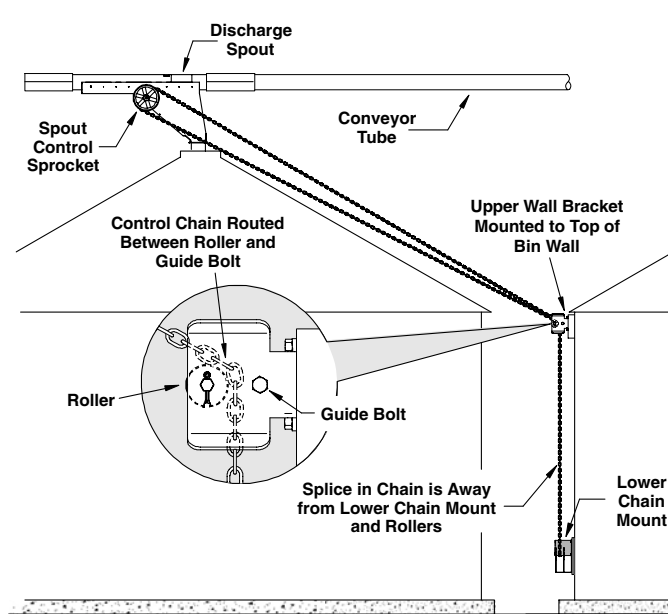

Example 4
Controls Mounted
on Adjacent Bin
(rollers mounted on outside of bracket)

DISCHARGE SPOUT with CHAIN
GROUND CONTROL GATES (con't.)

Install Chain Ground Control Components

1. Install the spout control sprocket onto spout shaft as shown below. Install the bushing onto the shaft using the 1/4" sq. x 3" long key and tighten setscrews to secure bushing to shaft. Attach the sprocket to the bushing using the bolts provided with the sprocket.

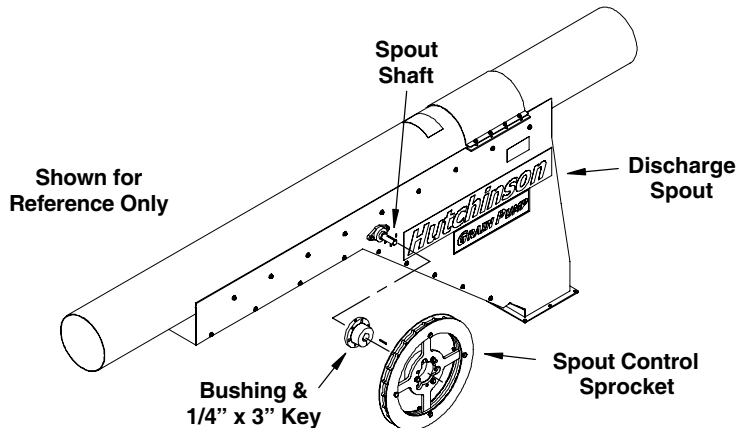

2. Attach the two rollers to the upper wall bracket using four (4) 3/8" x 1" bolts and nylon locknuts for each pulley (See illustration below).
 - If the controls are mounted on the same bin that the discharge spout is attached to, mount the pulleys on the inside of the wall bracket as shown in Example 3 on Page 40.
 - If the controls are mounted to an adjacent bin, mount the pulleys on the outside of the wall bracket as shown in Example 4 on Page 40.
3. Locate the wall bracket and rollers so they are in-line with the discharge spout control sprocket (this will allow the chain to track properly onto the spout control sprocket). Attach the wall bracket to the top of the bin wall in a position that allows the chain to clear the eave of the roof.

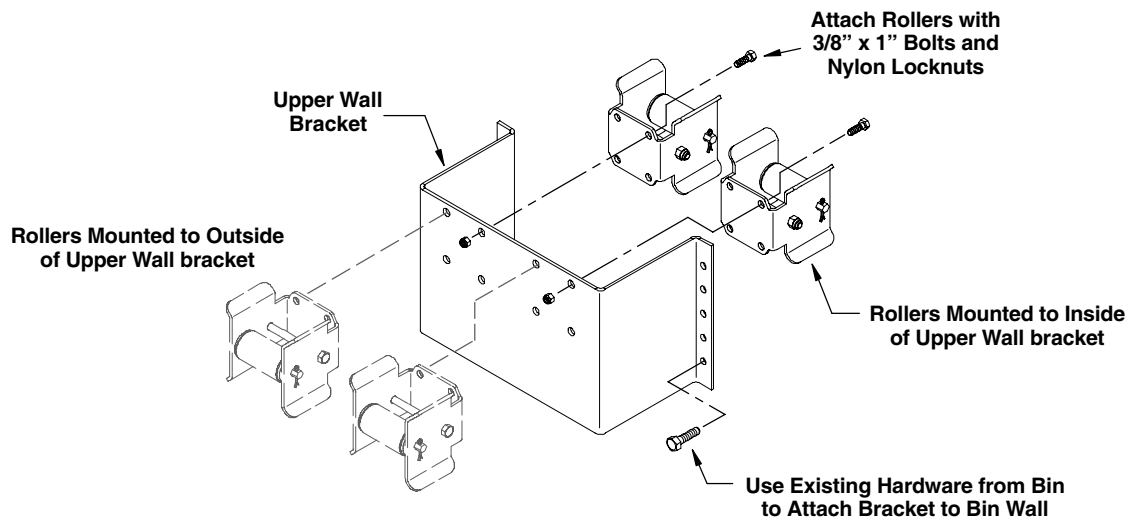

ASSEMBLY INSTRUCTIONS

Install Chain Ground Control Components (con't.)

4. Attach each wall plate to the lower chain mount as shown in Fig. 2 below. Secure each bracket using two (2) 3/8" x 1" bolts, four (4) flat washers and two (2) nylon locknuts. Slide the chain mount up so the bolts are at the bottom of the chain mount slots, but at the top of the wall plate slots (See illustration below).
5. Determine the location of the lower chain mount and attach the wall plates to the bin wall (use the existing hardware from the bin to mount the wall plates).

The bottom of the wall plates should be approximately 2' to 3' (61.0 cm to 91.4 cm) off the ground.

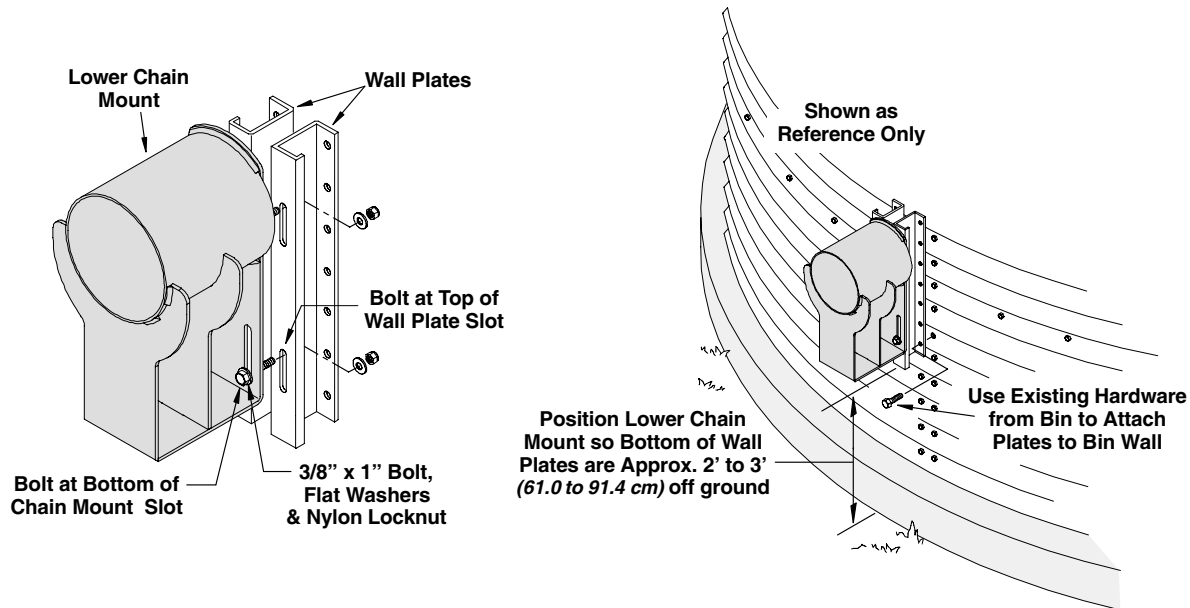

6. Route the control chain through one of the rollers on the wall bracket and up to the discharge spout control sprocket (make sure the chain is positioned between the roller and the guide bolt). **The chain can be clamped to the wall bracket to keep it from slipping through the bracket and roller while it is being routed up and around the control sprocket.**
 - Leave a good portion of the chain hanging below the roller on the wall bracket. This will be the end of the chain that will be spliced [this location is only a reference, it does not mean the splice has to be at this location. Just keep in mind that the splice (splices if more than one chain is used) need to be far enough away so it cannot be pulled onto the control sprocket, through a roller, or around the lower chain mount].
7. Route the chain down and behind the remaining roller on the wall bracket and down to the lower chain mount (make sure the chain is engaged with the teeth on the sprocket).
 Keeping the chain fairly taut, route the end of the chain to the portion of chain left hanging below the wall bracket roller. Connect the two ends of chain together using one (1) 3/16" threaded chain coupler. **The lower chain mount has adjustment slots to tighten the chain after it has been installed. If you determine that the chain is still too long, even after this adjustment has been made, cut off the excess chain length and then connect the ends together with the threaded coupler.**

Install Chain Ground Control Components (con't.)

- Loosen the bolts securing the lower chain mount to the wall plates. Slide the chain mount down to tighten the chain. Retighten the bolts securing the lower chain mount into place.

Note: 120' (36.58 m) of chain is included with this kit. If more chain is required for your application, keep in mind that the splices cannot be pulled onto the control sprocket, through a roller, or around the lower chain mount. Determine splice locations accordingly.

Operation Notes:

The controls should be clearly marked as to which spout they control to prevent accidentally discharging grain into the wrong bin.

Controls should be marked to indicate when a spout is open or closed.

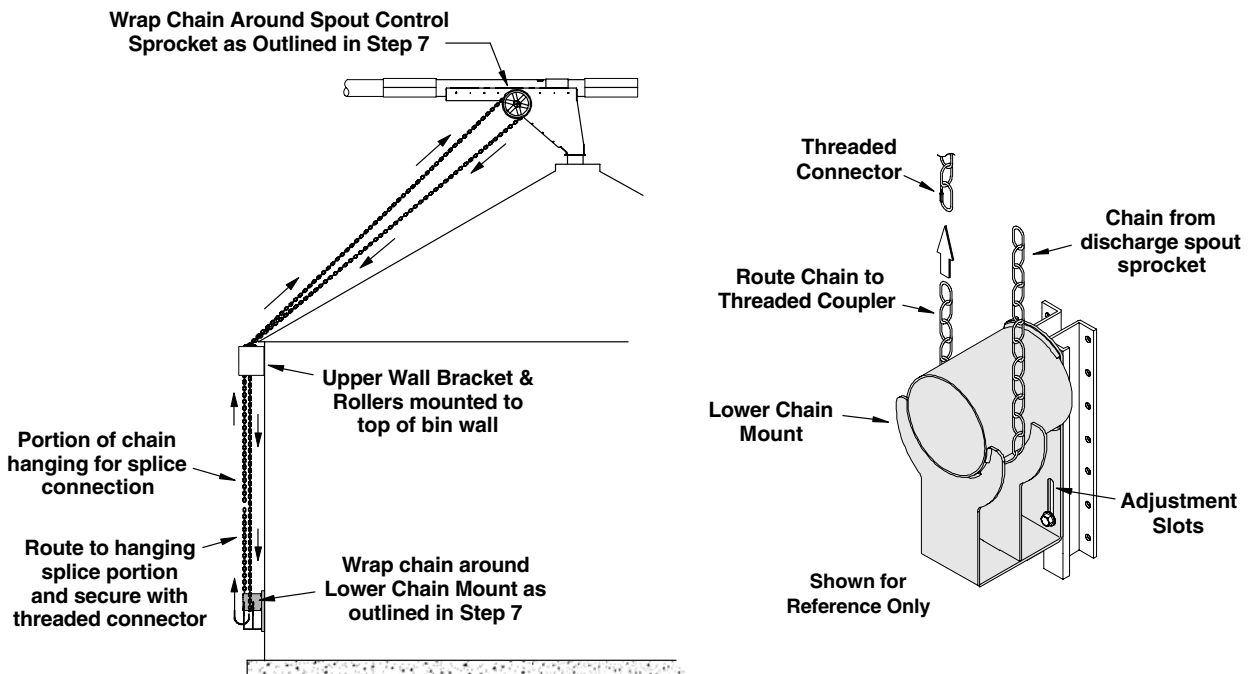

ASSEMBLY INSTRUCTIONS

BAND-ON INLET HOPPERS & INSPECTION PORTS

Inlet hoppers and inspection ports can be used within the loop system for various applications. They can be positioned in the conveyor system as extra inspection doors, or can be used in hard-to-reach places for clean-out purposes.

The hoppers can also be used as an alternative inlet hopper for allowing grain to enter into the loop system at locations other than the dump hopper.

The inlet hoppers and inspection ports are installed in the same manner as detailed below.

1. After location for the hopper has been determined, remove the cover and safety screen from the hopper.
Place the hopper on top of the conveyor tube and mark the conveyor tube from the inside of the hopper, leaving a minimum of 1/2" (13 mm) of tubing around all four sides of the hopper (See illustration below).
2. Verify the marks do not extend past the sides of the hopper (grain will leak out of the hopper if the opening is too large).
3. Cut and remove the section of conveyor tube previously marked, making sure to remove all pieces of cut material from inside the tube. Ensure cut edges of tubing are filed smooth so as not to cause interference with the paddles.
Note: Do Not cut openings in the conveyor tube when the chain and paddles are inside the tube. Damage to the chain and/or paddles can occur.
4. Secure the hopper to the conveyor tube using the back band and 5/16" x 1 1/2" bolts and non-lock nuts provided.

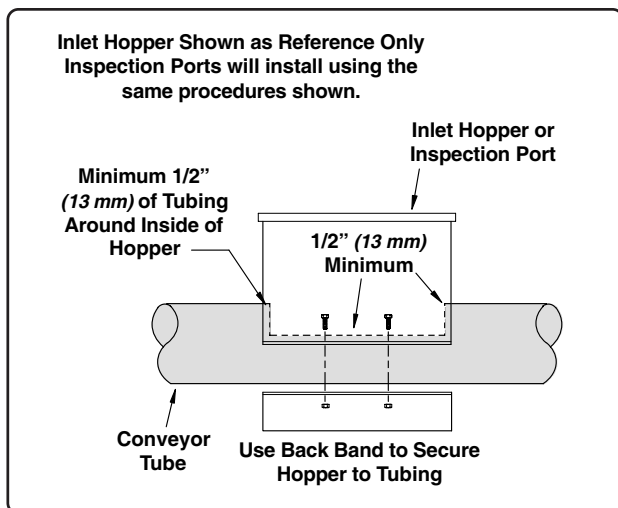

Fig. 19

CHAIN MAINTENANCE ACCESS HOPPER

Chain maintenance access sections are available for use on the horizontal tubes only.

The access sections are typically installed between the drive-over pit and first corner section, but can be installed anywhere in the loop system as long as they are installed on the horizontal tubes.

1. After location for the access section(s) has been determined, connect to the conveyor tubes using the connecting bands provided. Tighten connecting bands as shown below.

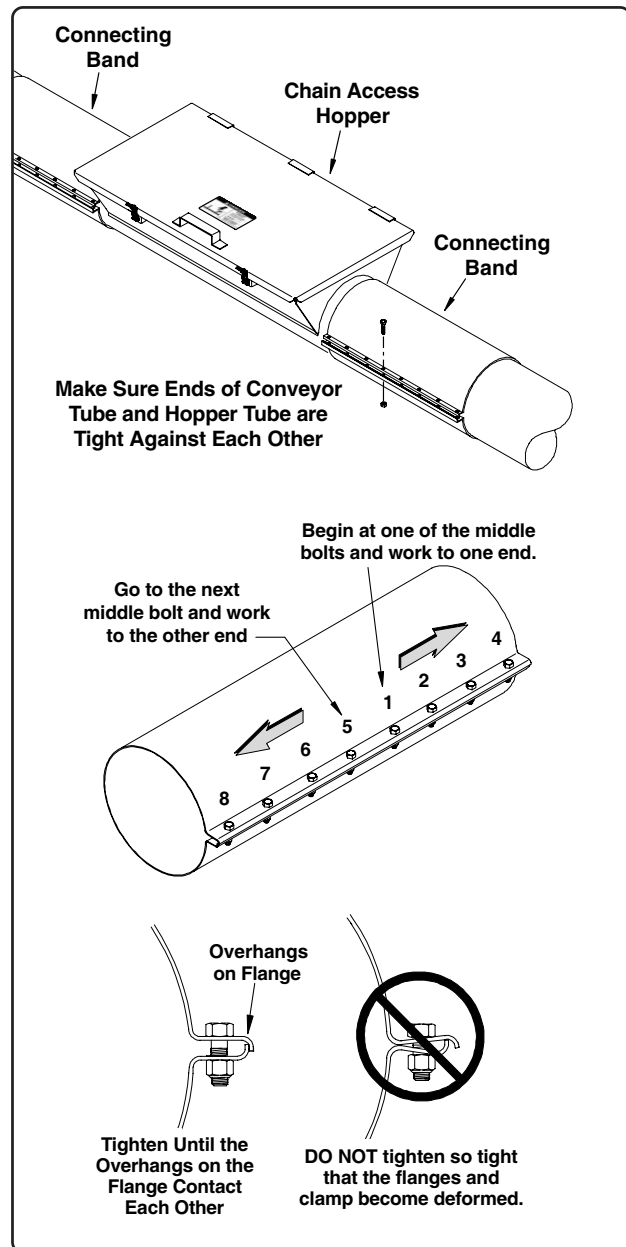

Fig. 20

12" Commercial Grain Pump Loop System

<i>Decals and Safety Signs</i>	<i>P-2 to P-3</i>
<i>Manual Take-Up Inspection Corner</i>	<i>P-4 to P-5</i>
<i>Auto Take-Up Inspection Corner</i>	<i>P-6 to P-7</i>
<i>Drive Corner, 50 hp & 60 hp</i>	<i>P-8 to P-9</i>
<i>Drive Corner, 75 hp</i>	<i>P-10 to p-11</i>
<i>Drive Corner, 100 hp</i>	<i>P-12 to P-13</i>
<i>Standard Corner, 50 hp & 60 hp</i>	<i>P-14</i>
<i>Standard Corner, 75 hp & 100 hp</i>	<i>P-15</i>
<i>90° Discharge Assemblies, w/ Gate</i>	<i>P-16</i>
<i>Chain & Paddle Assemblies (Single Strand & Double Strand)</i>	<i>P-17</i>
<i>Ground Control Wheel (w/ Cable)</i>	<i>P-17</i>
<i>Ground Control Wheel (w/ Chain)</i>	<i>P-18</i>
<i>Inlet Hopper</i>	<i>P-18</i>
<i>Connecting Band w/ Inspection Port</i>	<i>P-19</i>
<i>Inspection Port</i>	<i>P-19</i>
<i>Rack & Pinion Control (Manual, 30" Travel)</i>	<i>P-20 to P-21</i>
<i>Rack & Pinion Control (Electric, 30" Travel)</i>	<i>P-22 to P-23</i>
<i>Rack & Pinion Control (Standard, 18" Travel)</i>	<i>P-24</i>
<i>Center Binwell f/ 12" Commercial Grain Pump</i>	<i>P-25</i>
<i>Intermediate Binwell f/ 12" Commercial Grain Pump</i>	<i>P-26</i>
<i>Center Binwell f/ 12" Grain Pump (Standard)</i>	<i>P-27</i>
<i>Intermediate Binwell f/ 12" Grain Pump (Standard)</i>	<i>P-28</i>
<i>Dump Hoppers, 2-Grate, 5-Grate & 6-Grate</i>	<i>P-29</i>
<i>Dump Hopper, 7-Grate w/ Electric Rack & Pinion Gates</i>	<i>P-30 to P-31</i>
<i>Truck Dump Hopper, 2-Grate w/ Electric Rack & Pinion Gate</i>	<i>P-32</i>
<i>Flat Storage Well w/ Electric Slide Gate</i>	<i>P-33</i>
<i>Chain Maintenance Access Assembly</i>	<i>P-34</i>

PARTS LIST

SAFETY SIGNS and DECALS

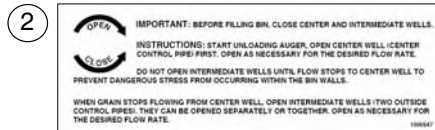

Ref. No.	Part No.	Description	Ref. No.	Part No.	Description
1	1001985	Danger, Rotating Auger	7	1012785	Decal, Chain Travel
2	1006947	Rack & Pinion Controls	8	1001127	Decal, Hutchinson (rectangle)
3	1012872	Danger, Moving Chain Hazard	9	1033033	Caution, Grain Pump Loop Fill
4	1002310	Danger, Do Not Operate with Cover Open	10	1002301	Caution, General Statement
5	1002305	Danger, Keep Out of Bin...	11	1041833	Decal, Made in America
6	1001128	Decal, Hutchinson Globe	12	34349	Decal, Grain Pump

SAFETY DECAL LOCATIONS on SYSTEM COMPONENTS

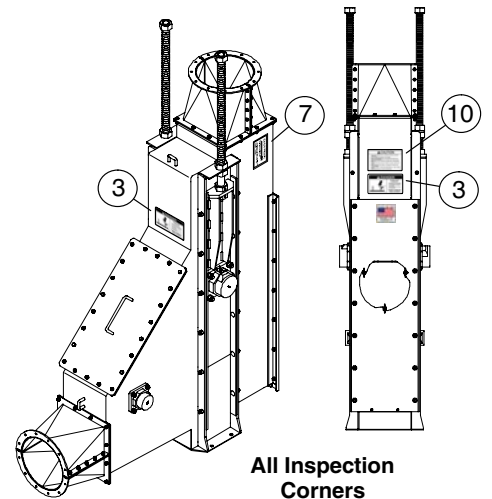
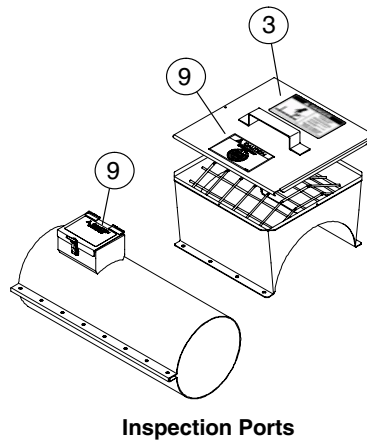
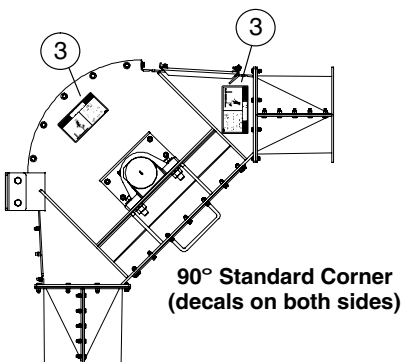
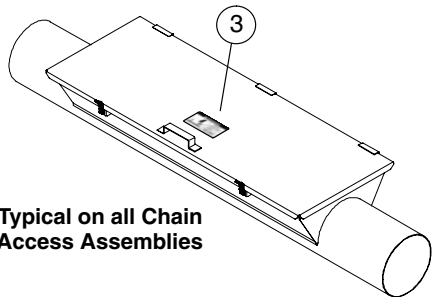
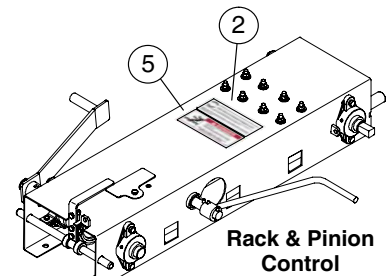
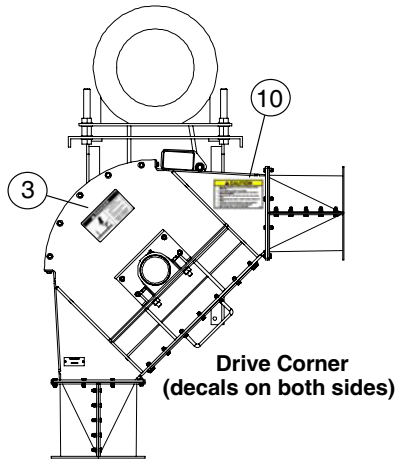
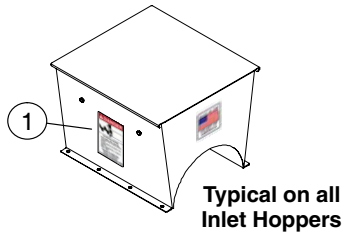
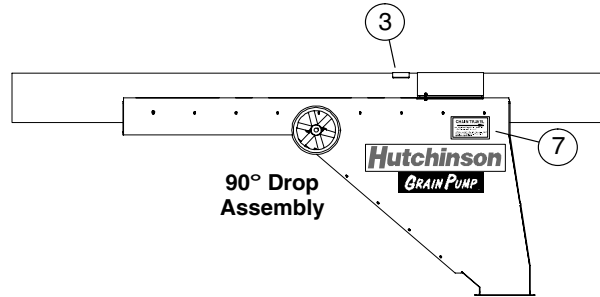
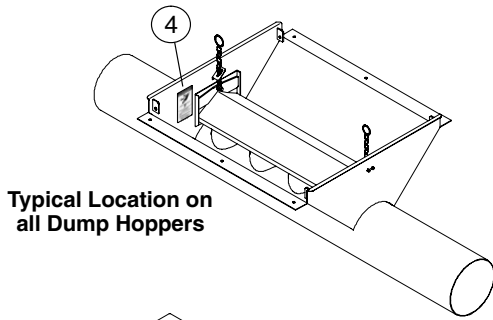

PARTS LIST

MANUAL TAKE-UP CORNER ASSEMBLY (INSPECTION CORNER)

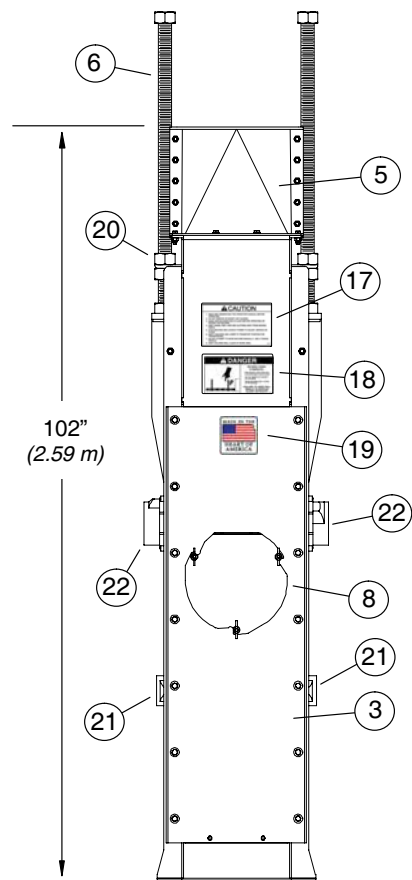
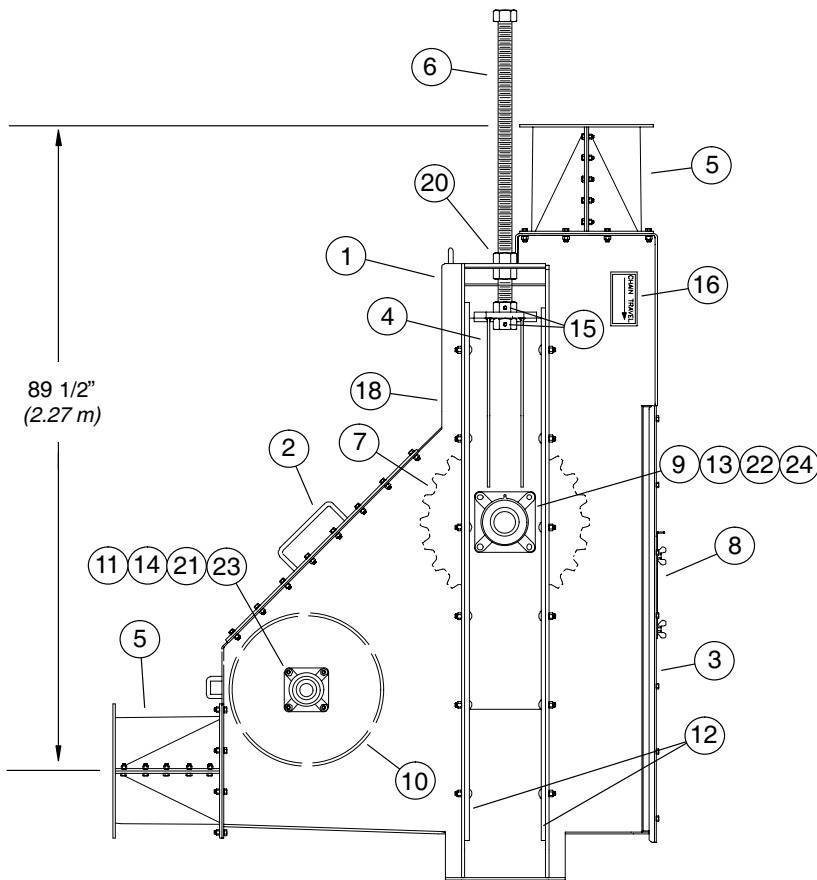
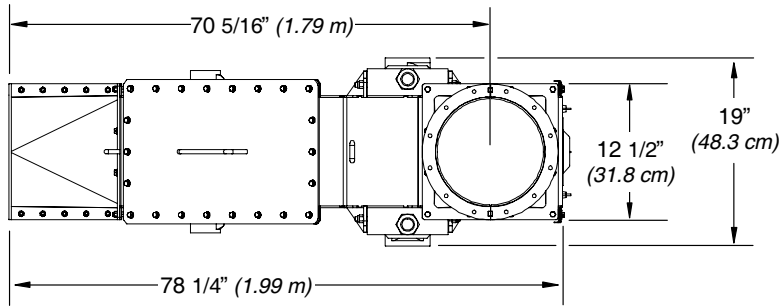

MANUAL TAKE-UP CORNER ASSEMBLY
(INSPECTION CORNER)

Ref. No.	Part No.	Description	Ref. No.	Part No.	Description
1	1041347	Manual Take-Up Corner Weldment	13	1029502	Bearing, 4-bolt flange 2 7/16" bore
2	1039405	Cover, Inside Panel	14	1023389	Shaft, Idler Sprocket
3	1023392	Inspection Door (rear)	15	33203	Roll Pin, 3/8" x 2 1/2" long
4	1023385	Slide Weldment	16	1012785	Decal, Chain Travel
5	1039295	Square-to-Round Weldment (12")	17	1002301	Decal, Caution, General Operator
6	1017180	Rod, Threaded Adjustable	18	1012872	Decal, Danger, Do Not Operate...
7	1039786	Sprocket, 22 tooth	19	1041833	Decal, Made in America
8	1023397	Cover, Peek Hole	20	1017118	Nut, 1/2" - 13 Non-Lock
9	1023390	Shaft, Inspection Corner	21	1038087	Bearing Cap
10	1023296	Wheel, Traction	22	1038088	Bearing Cap
11	1029182	Bearing, 4-bolt flange, 1 1/2" bore	23	4021L1	Key, 1/2" sq. x 2 3/4" long
12	1026147	Slide Guide Strip	24	1017144	Key, 7/8" sq. x 5" long

Item No. 2 (Cover Panel) is attached using:
33060 – 3/8" x 1" Bolts, D1150 – 3/8" Lock Washers,
D1149 – 3/8" Non-Lock Nuts

Item No. 3 (Inspection Door) is attached using:
33060 – 3/8" x 1" Bolts, 33024 – 3/8" Flat Washers,
33136 – 3/8" Nylon Locknuts

Item No. 5 (Square to Round Weldments) are attached to the Inspection Corner using:
33060 – 3/8" x 1" Bolts, D1150 – 3/8" Lock Washers,
33136 – 3/8" Nylon Locknuts

Item No. 5 (Square to Round Weldments) are attached together using:
33229 – 3/8" x 1 1/4" Bolts,
33136 – 3/8" Nylon Locknuts

Item No. 8 (Hole Cover) is attached using:
1018332 – 3/8" Wing Nut

Item No. 11 (Bearings) are attached using:
1002227 – 1/2" x 1 1/2" Bolts, D1143 – 1/2" Lock Washers,
D1169 – 1/2" Non-Lock Nuts

Item No. 12 (Guide Straps) are attached using:
1002243 – 1/2" x 1 1/2" Carriage Bolts,
33138 – 1/2" Nylon Locknuts

Item No. 13 (Bearings) are attached using:
D1171 – 5/8" Lock Washers,
D1170 – 5/8" Non-Lock Nuts

PARTS LIST

AUTO TAKE-UP CORNER ASSEMBLY (INSPECTION CORNER)

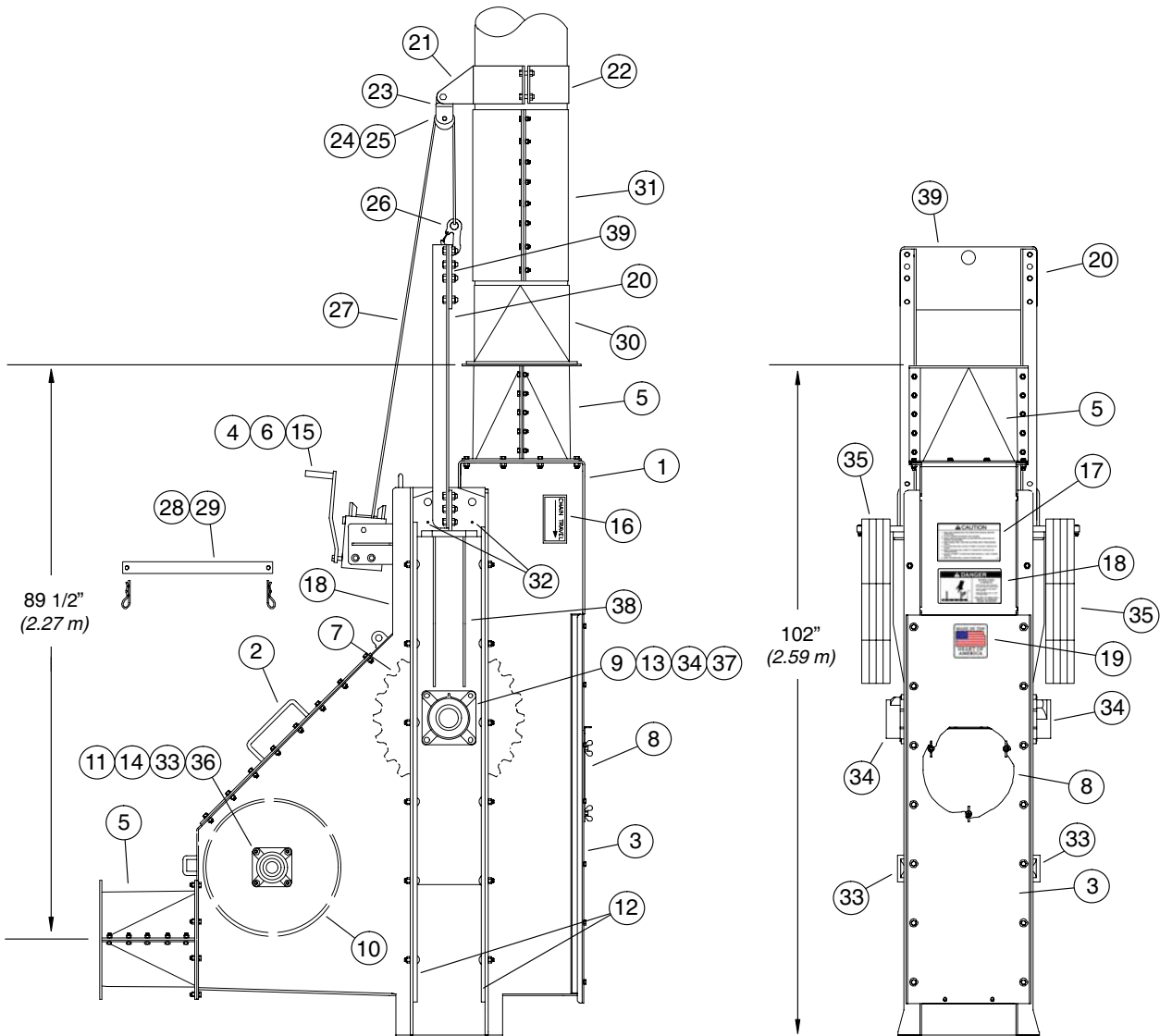
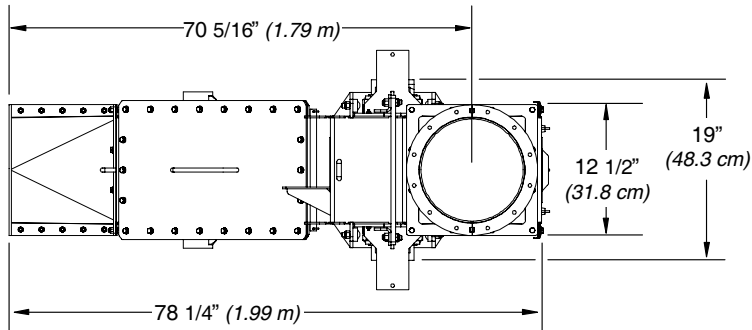

AUTO TAKE-UP CORNER ASSEMBLY (INSPECTION CORNER)

Ref. No.	Part No.	Description	Ref. No.	Part No.	Description
1	1039384	Auto Take-Up Corner Weldment	21	1025284	Bracket Weldment, Pulley
2	1039405	Cover, Inside Panel	22	5931A1	Half-Band, 12" x 4" Wide
3	1023392	Inspection Door (rear)	23	1007890	Cable Pulley Side
4	3335A1	Winch Assembly, K1550	24	1008195	Pulley, Cable, 1/4" x 3" O.D.
5	1039295	Square-to-Round Weldment (12")	25	50079A1	Bushing, 1" O.D. x 5/8" long
6	41595	Handle, Winch f/ K1550	26	106411	Hook w/ Safety Clip
7	1039786	Sprocket, 22 tooth	27	1011852	Cable, 1/4" dia. x 10'-0" long
8	1023397	Cover, Peek Hole	28	1026150	Bar, Block Out
9	1023390	Shaft, Inspection Corner	29	635164	Hair Pin, 3/32" dia. x 2" long
10	1023296	Wheel, Traction	30	1039454	Tube Section w/ Flange
11	1023389	Shaft, Idler Sprocket	31	1224D	Band, Connecting 12' x 30"
12	1026147	Slide Guide Strip	32	3030A1	Grease Zerk, 1/4" straight
13	1029502	Bearing, 4-Bolt Flange, 2 7/16"	33	1038087	Bearing Cap f/ 1029182 Bearing
14	1029182	Bearing, 4-bolt flange, 1 1/2" bore	34	1038088	Bearing Cap f/ 1029502 Bearing
15	41600	Keeper Kit f/ Winch K1550	35	1022554	Weights, 50 lbs. (23 kg) ea.
16	1012785	Decal, Chain Travel	36	4021L1	Key, 1/2" sq. x 2 3/4" long
17	1002301	Decal, Caution - General Operator	37	1017144	Key, 7/8" sq. x 5" long
18	1012872	Decal, Danger Do Not Operate...	38	1039748	Slide Weldment
19	1041833	Decal, Made in America	39	1026151	Lifting Plate
20	1026144	Angle, Slide Lift			

Item No. 2 (Cover Panel) is attached using:
33060 – 3/8" x 1" Bolts, D1150 – 3/8" Lock Washers,
D1149 – 3/8" Non-Lock Nuts

Item No. 3 (Inspection Door) is attached using:
33060 – 3/8" x 1" Bolts, 33024 – 3/8" Flat Washers,
33136 – 3/8" Nylon Locknuts

Item No. 4 (Winch) is attached using:
33060 – 3/8" x 1" Bolts, 33024 – 3/8" Flat Washers,
33136 – 3/8" Nylon Locknuts

Item No. 5 (Square to Round Weldments) are attached to the Inspection Corner using:
33060 – 3/8" x 1" Bolts, D1150 – 3/8" Lock Washers,
33136 – 3/8" Nylon Locknuts

Item No. 5 (Square to Round Weldments) are attached together using:
33229 – 3/8" x 1 1/4" Bolts,
33136 – 3/8" Nylon Locknuts

Item No. 8 (Hole Cover) is attached using:
1018332 – 3/8" Wing Nut

Item No. 12 (Guide Straps) are attached using:
1002243 – 1/2" x 1 1/2" Carriage Bolts,
33138 – 1/2" Nylon Locknuts

Item No. 13 (Bearings) are attached using:
D1171 – 5/8" Lock Washers,
D1170 – 5/8" Non-Lock Nuts

Item No. 14 (Bearings) are attached using:
1002227 – 1/2" x 1 1/2" Bolts, D1143 – 1/2" Lock Washers,
D1169 – 1/2" Non-Lock Nuts

Item No. 20 (Slide Lift Angles) are attached to Slide Weldments using:
1002227 – 1/2" x 1 1/2" Bolts,
33138 – 1/2" Nylon Locknuts

Item No. 23 (Pulley Sides) are attached to Pulley using:
1002228 – 1/2" x 2" Bolts,
33138 – 1/2" Nylon Locknuts

Item No. 24 (Pulley) is attached to Pulley Bracket using:
1002229 – 1/2" x 2 1/2" Bolts,
33138 – 1/2" Nylon Locknuts

Item No. 30 (Tube Section) is attached to Square to Round using:
33060 – 3/8" x 1" Bolts,
33136 – 3/8" Nylon Locknuts

Item No. 31 (Connecting Band) is secured using:
33310 – 3/8" x 1 1/2" Bolts,
33136 – 3/8" Nylon Locknuts

Item No. 35 (Weights) are secured from sliding off support bar using:
33310 – 3/8" x 1 1/2" Bolts,
33136 – 3/8" Nylon Locknuts

Item No. 39 (Lifting Plate) is attached using:
1002227 – 1/2" x 1 1/2" Bolts,
33138 – 1/2" Nylon Locknuts

PARTS LIST

DRIVE CORNER ASSEMBLY

50 and 60 HP (37 & 45 kw)

Drive Corner (Standard)

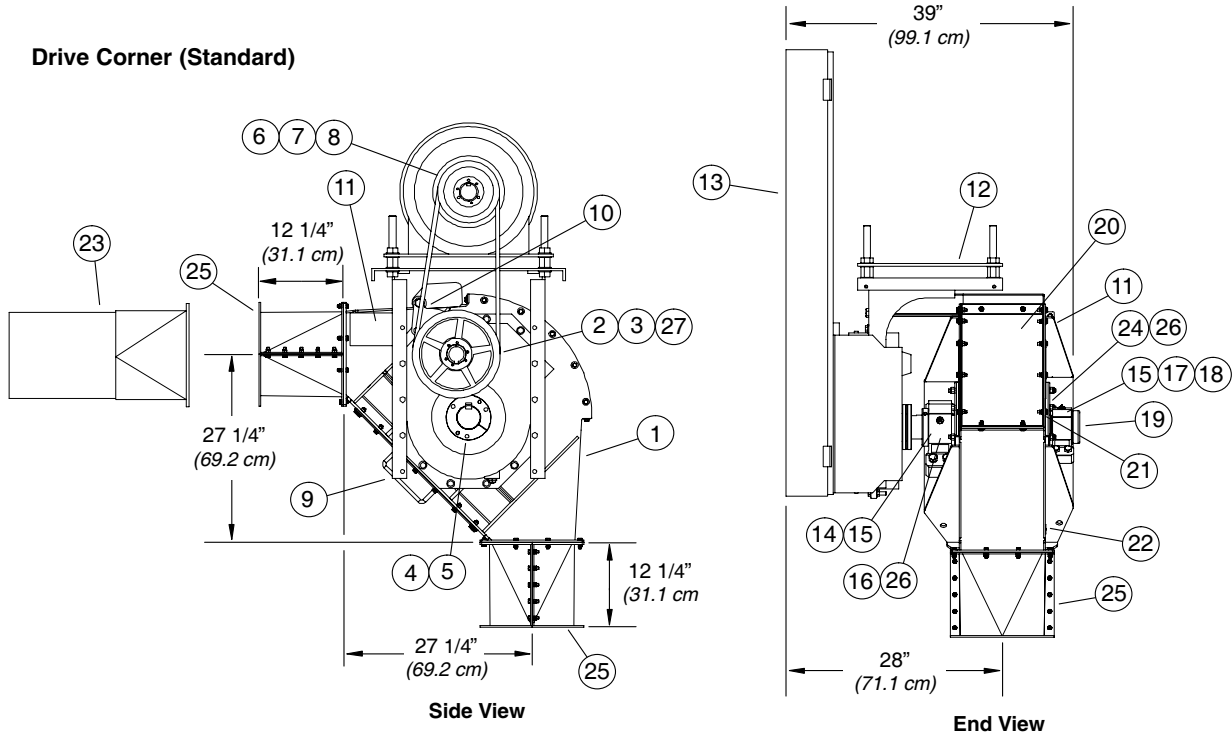

Drive Corner (Reversed)

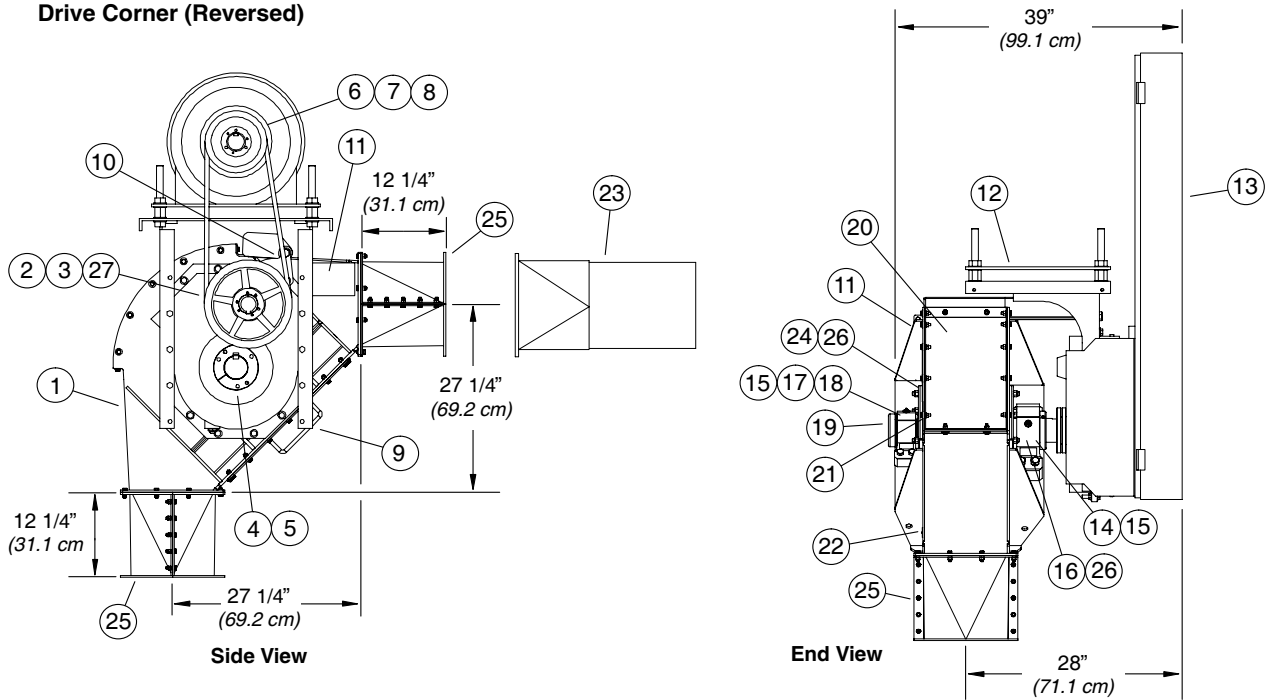

The reversed drive corner has the same components as the standard drive corner, the only difference is the housing. The housing for the reversed drive corner was designed so all components could be mounted on the housing in the opposite as compared to the standard drive corner.

DRIVE CORNER ASSEMBLY

50 and 60 HP (37 & 45 kw)

Parts listed below are used on both the 50 hp & 60 hp (37 & 45 kw) models unless otherwise noted.

Ref. Part No. No.	Description	Ref. Part No. No.	Description
1 1040748	Drive Corner (50 hp)*	13 1023782	Belt Guard (50 hp)
(1) 1040814	Drive Corner (60 hp)*	(13) 1025375	Belt Guard (60 hp)
2 3091A1	Sheave QD 4B 12.4" (50 hp)	14 1023252	Bearing, Pillow Block, 3 7/16"
(2) 3091A1	Sheave, QD 4B 12.4" (60 hp)	15 1023299	Seal, Plastic (50 & 60 hp)
3 3192A1	Bushing, QD SK 1 5/8" (50 hp)	16 1023784	Shaft (50 hp)
(3) 3048L1	Bushing QD SK 2 3/16" (60 hp)	(16) 1025381	Shaft (60 hp)
4 1023780	Gear Reducer (50 hp)	17 1023253	Bearing, Pillow Block, 2 7/16"
(4) 1025373	Gear Reducer (60 hp)	18 1039786	Sprocket, 22 tooth
5 1023783	Kit, Bushing f/ Reducer (50 hp)	19 1038086	Bearing Cap
(5) 1025376	Kit, Bushing f/ Reducer (60 hp)	20 1023314	Cover, f/ Grain Pump Corner
6 3273A1	Sheave, QD 4B 8.6"	21 1012872	Decal, Danger, Do Not Operate...
7 3281A1	Bushing, QD SK 2 1/8" (50 hp)	22 34687	Serial Plate
(7) 1025332	Bushing, QD SK 2 3/8" (60 hp)	23 1039454	Tube Section w/ Flange
8 40130	Belt, B-88 (50 hp)	24 1017144	Key, 7/8" sq. x 5" long
(8) 1025393	Belt, B-85 (60 hp)	25 1039295	Square-to-Round Weldment
9 1039288	Panel, Inside Cover	26 1038077	Seal Hold-Down
10 1023795	Bracket, Reducer (50 hp)	27 1025377	Fan, Reducer Cooling (60 hp)
(10) 1025380	Bracket, Reducer (60 hp)		
11 1002301	Decal, Caution General Operator		
12 1023781	Mount Motor (50 hp)		
(12) 1025374	Mount, Motor (60 hp)		

For 50 hz Drive Corners the following Sheave and Bushings should be used:

Item 2 - 3274A1, Sheave QD 4B 11.0" (37 & 45 kw); Item 3 - 3192A1, Bushing QD SK 1 5/8" (37 kw)

Item 3 - 3048L1, Bushing QD SK 2 3/16" (45 kw); Item 6 - 3093A1, Sheave QD 4B 9.4" (37 & 45 kw)

Item 7 - 3281A1, Bushing QD SK 2 1/8" (37 kw); Item 7 - 1025332, Bushing QD SK 2 3/8" (45 kw)

***To obtain the Reversed Drive Corner, Order Part No's:**

1040748-Rev f/ 50 hp Models

1040814-Rev f/ 60 hp Models

Item No. 9 (Cover Panel) is attached using:

33229 – 3/8" x 1 1/4" Bolts, D1150 – 3/8" Lock Washers, D1149 – 3/8" Non-Lock Nuts

Item No. 10 (Reducer Bracket) is attached using:

33111 – 3/4" x 2 1/2" Bolt, 33027 – 3/4" Flat Washer, 33140 – 3/4" Nylon Locknut

Item No. 14 (Bearing) is attached using:

33250 – 3/4" x 4" Bolts, D1153 – 3/4" Lock Washer, D1152 – 3/4" Non-Lock Nut

Item No's. 15 & 26 (Seal & Hold-Down Plate) are attached using:

1002243 – 1/2" x 1 1/2" Carriage Bolts, 33138 – 1/2" Nylon Locknut

Item No. 17 (Bearing) is attached using:

4911 – 1/2" x 3 1/2" Bolts, D1143 – 1/2" Lock Washers, D1169 – 1/2" Non-Lock Nuts

Item No. 20 (Cover) is attached using:

33229 – 3/8" x 1 1/4" Bolts, 33024 – 3/8" Flat Washers D1150 – 3/8" Lock Washer, D1149 – 3/8" Non-Lock Nut

Item No. 25 (Square to Round Weldments) are attached to the Drive Corner using:

33060 – 3/8" x 1" Bolts, 33229 – 3/8" x 1 1/4" Bolts, D1150 – 3/8" Lock Washers, 33136 – 3/8" Nylon Locknuts

Item No. 25 (Square to Round Weldments) are attached together using:

33229 – 3/8" x 1 1/4" Bolts, 33136 – 3/8" Nylon Locknuts

PARTS LIST

DRIVE CORNER ASSEMBLY

75 HP (55 kw)

Drive Corner (Standard)

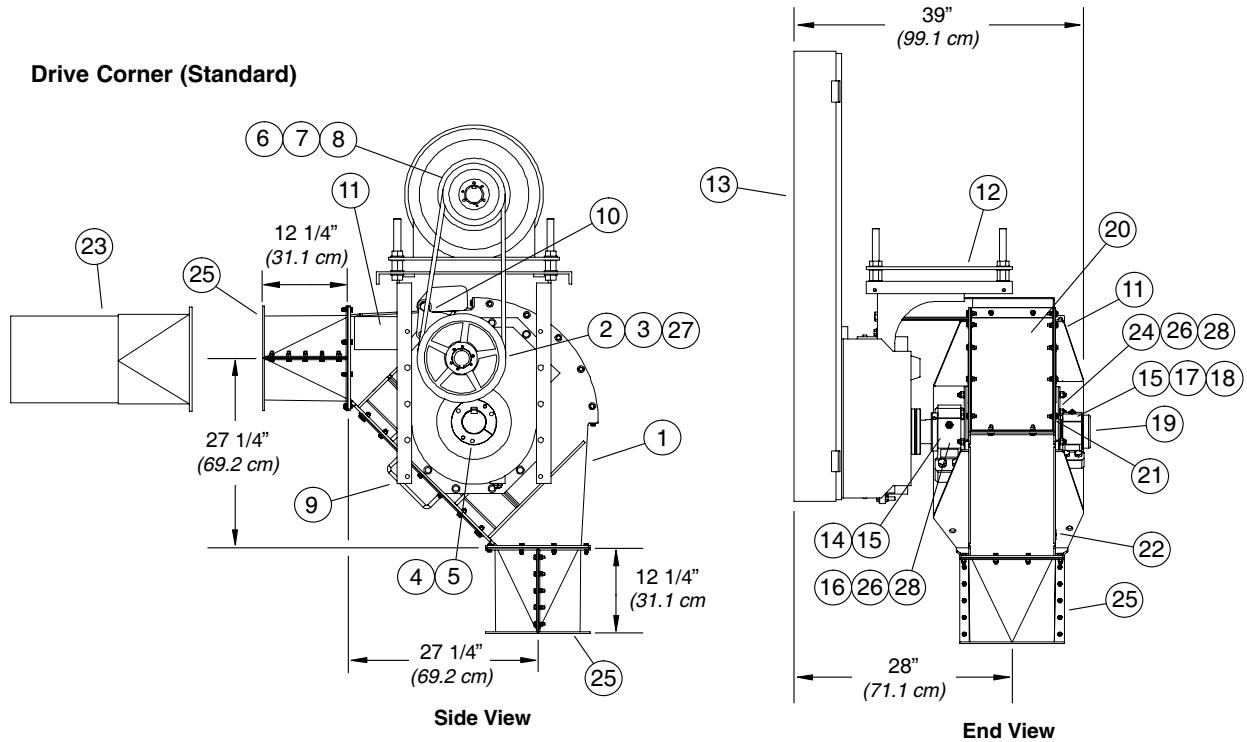

Drive Corner (Reversed)

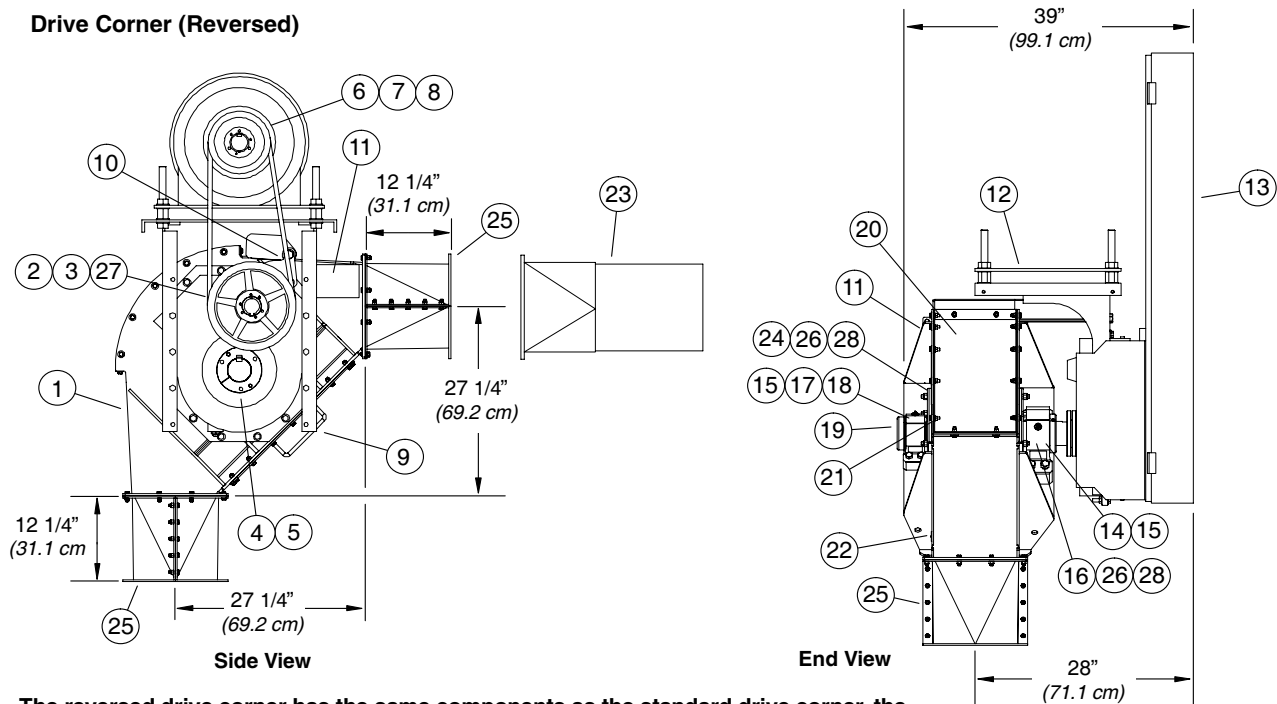

The reversed drive corner has the same components as the standard drive corner, the only difference is the housing. The housing for the reversed drive corner was designed so all components could be mounted on the housing in the opposite as compared to the standard drive corner.

DRIVE CORNER ASSEMBLY

75 HP (55 kw)

Ref. Part No. No.	Description	Ref. Part No. No.	Description
1 1040816	Drive Corner (75 hp)*	15 1033618	Seal, 1/2" UHMW Plastic
2 3095A1	Sheave, QD 5B 12.4"	16 1040824	Shaft
3 3187A1	Bushing, QD SF 2 3/16	17 1033565	Bearing, Pillow Block, 2 15/16"
4 1025373	Gear Reducer	18 1039388	Sprocket, 22 tooth
5 1025376	Kit, Bushing f/ Reducer	19 1039358	Bearing Cap
6 3275A1	Sheave, QD 5B 8.6"	20 1023314	Cover, f/ Grain Pump Corner
7 1016991	Bushing, QD SF 2 3/8"	21 1012872	Decal, Danger, Do Not Operate...
8 40129	Belt, B-83	22 34687	Serial Plate
9 1039288	Panel, Inside Cover	23 1039454	Tube Section w/ Flange
10 1040827	Bracket, Reducer	24 1033623	Key, 1" sq. x 8" long
11 1002301	Decal, Caution General Operator	25 1039295	Square-to-Round Weldment
12 1025374	Mount, Motor	26 1039303	Seal Hold-Down
13 1025375	Belt Guard	27 1025377	Fan, Reducer Cooling
14 1033564	Bearing, Pillow Block, 3 15/16"	28 1033567	Bearing Stop

For 50 hz Drive Corners the following Sheave, Bushings and Belts should be used:

Item 2 - 1031831, Sheave QD 5B 11.0" (55 kw); Item 3 - 3187A1, Bushing QD SF 2 3/16" (55 kw)
 Item 6 - 3094A1, Sheave QD 5B 9.4" (55 kw); Item 7 - 1016991, Bushing QD SF 2 3/8" (55 kw);
 Item 8 - 40340, Belt B-81 (55 kw)

***To obtain the Reversed Drive Corner, Order Part No:
 1040816-Rev f/ 75 hp Models**

Item No. 9 (Cover Panel) is attached using:

33229 – 3/8" x 1 1/4" Bolts, D1150 – 3/8" Lock Washers,
 D1149 – 3/8" Non-Lock Nuts

Item No. 10 (Reducer Bracket) is attached using:

33111 – 3/4" x 2 1/2" Bolt, 33027 – 3/4" Flat Washer,
 33140 – 3/4" Nylon Locknut

Item No. 14 (Bearing) is attached using:

33250 – 3/4" x 4" Bolts, D1153 – 3/4" Lock Washer,
 D1152 – 3/4" Non-Lock Nut

Item No's. 15 & 26 (Seal & Hold-Down Plate) are attached using:

1002243 – 1/2" x 1 1/2" Carriage Bolts,
 33138 – 1/2" Nylon Locknut

Item No. 17 (Bearing) is attached using:

33103 – 5/8" x 3 1/2" Bolts, D1171 – 5/8" Lock Washers,
 D1170 – 5/8" Non-Lock Nuts

Item No. 20 (Cover) is attached using:

33229 – 3/8" x 1 1/4" Bolts, 33024 – 3/8" Flat Washers
 D1150 – 3/8" Lock Washer, D1149 – 3/8" Non-Lock Nut

Item No. 25 (Square to Round Weldments) are attached to the Drive Corner using:

33060 – 3/8" x 1" Bolts, 33229 – 3/8" x 1 1/4" Bolts,
 D1150 – 3/8" Lock Washers, 33136 – 3/8" Nylon Locknuts

Item No. 25 (Square to Round Weldments) are attached together using:

33229 – 3/8" x 1 1/4" Bolts,
 33136 – 3/8" Nylon Locknuts

PARTS LIST

DRIVE CORNER ASSEMBLY 100 HP (75 kw)

Drive Corner (Standard)

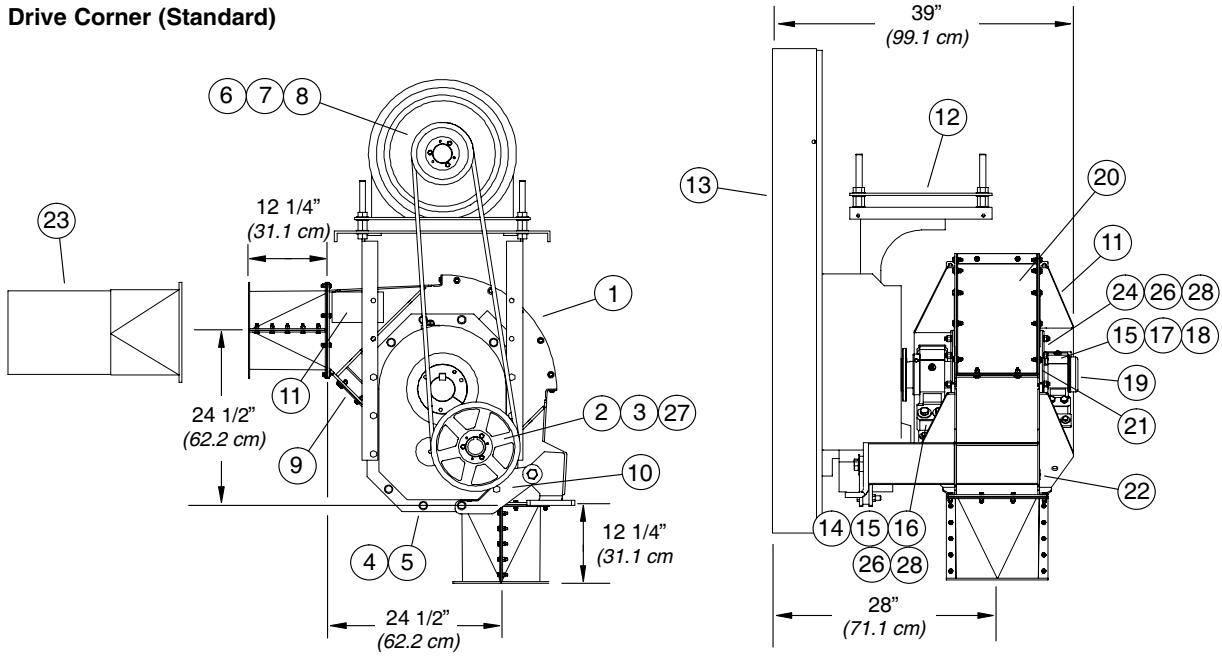

Drive Corner (Reversed)

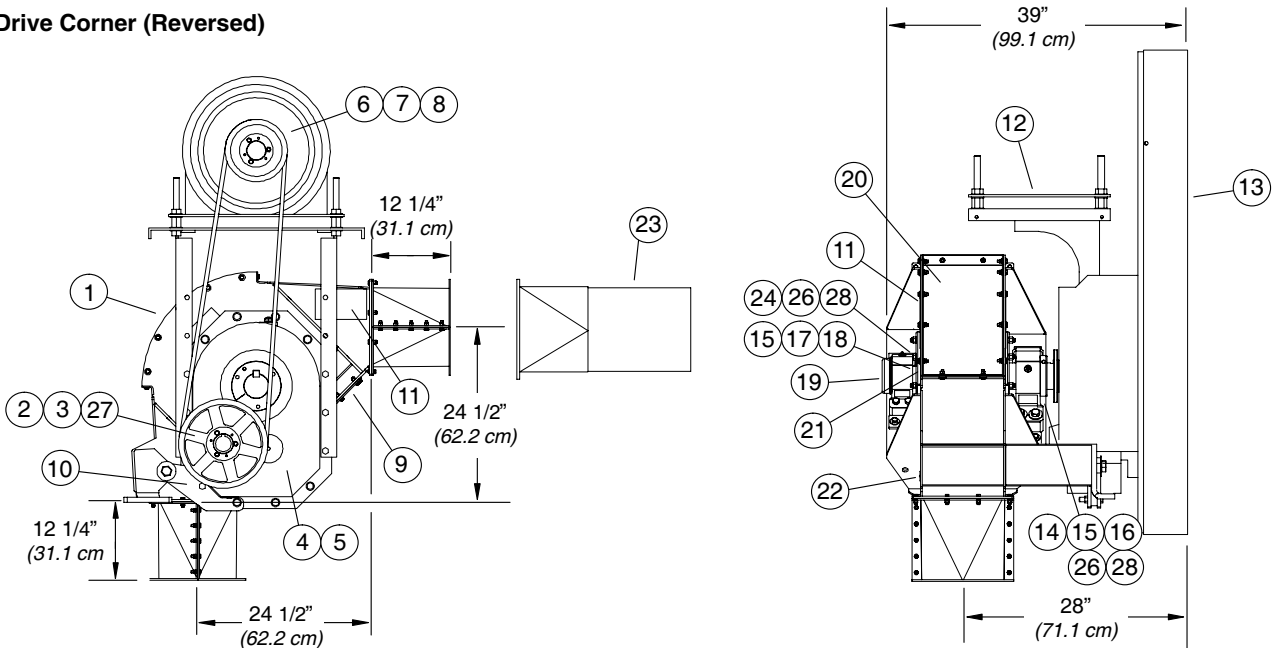

The reversed drive corner has the same components as the standard drive corner, the only difference is the housing. The housing for the reversed drive corner was designed so all components could be mounted on the opposite side of the housing as compared to the standard drive corner.

DRIVE CORNER ASSEMBLY

100 HP (75 kw)

Ref. No.	Part No.	Description	Ref. No.	Part No.	Description
1	1039339	Drive Corner (100 hp)*	15	1033618	Seal, 1/2" UHMW Plastic
2	1033624	Sheave, QD 6B 13.6"	16	1033553	Shaft
3	3284A1	Bushing, QD SF 2 7/16"	17	1033565	Bearing, Pillow Block, 2 15/16"
4	1033626	Gear Reducer	18	1039388	Sprocket, 22 tooth
5	1033627	Kit, Bushing f/ Reducer	19	1039358	Bearing Cap
6	1033625	Sheave, QD 6B 9.4"	20	1023314	Cover, f/ Grain Pump Corner
7	1033637	Bushing, QD SF 2 7/8"	21	1012872	Decal, Danger, Do Not Operate...
8	1039381	Belt, B-131	22	34687	Serial Plate
9	1039288	Panel, Inside Cover	23	1039454	Tube Section w/ Flange
10	1039383	Bracket, Reducer Mount	24	1033623	Key, 1" sq. x 8" long
11	1002301	Decal, Caution General Operator	25	1039295	Square-to-Round Weldment
12	1033630	Mount, Motor	26	1039303	Seal Hold-Down
13	1035847	Belt Guard	27	1025377	Fan, Reducer Cooling
14	1033564	Bearing, Pillow Block, 3 15/16"	28	1033567	Bearing Stop

For 50 hz Drive Corners the following Sheave, Bushings and Belts should be used:

Item 2 - 1033624, Sheave QD 6B 13.6" (75 kw); Item 3 - 3284A1, Bushing QD SF 2 7/16" (75 kw)
 Item 6 - 1035827, Sheave QD 6B 11.0" (75 kw); Item 7 - 1033637, Bushing QD SF 2 7/8" (75 kw);
 Item 8 - 1039475, Belt B-133 (75 kw)

***To obtain the Reversed Drive Corner, Order Part No:
 1039339-Rev f/ 100 hp Models**

Item No. 9 (Cover Panel) is attached using:

33229 – 3/8" x 1 1/4" Bolts, D1150 – 3/8" Lock Washers,
 D1149 – 3/8" Non-Lock Nuts

Item No. 10 (Reducer Bracket) is attached using:

33111 – 3/4" x 2 1/2" Bolt, 33027 – 3/4" Flat Washer,
 33140 – 3/4" Nylon Locknut

Item No. 14 (Bearing) is attached using:

33250 – 3/4" x 4" Bolts, D1153 – 3/4" Lock Washer,
 D1152 – 3/4" Non-Lock Nut

Item No's. 15 & 26 (Seal & Hold-Down Plate) are attached using:

1002243 – 1/2" x 1 1/2" Carriage Bolts,
 33138 – 1/2" Nylon Locknut

Item No. 17 (Bearing) is attached using:

33103 – 5/8" x 3 1/2" Bolts, D1171 – 5/8" Lock Washers,
 D1170 – 5/8" Non-Lock Nuts

Item No. 20 (Cover) is attached using:

33229 – 3/8" x 1 1/4" Bolts, 33024 – 3/8" Flat Washers
 D1150 – 3/8" Lock Washer, D1149 – 3/8" Non-Lock Nut

Item No. 25 (Square to Round Weldments) are attached to the Drive Corner using:

33060 – 3/8" x 1" Bolts, 33229 – 3/8" x 1 1/4" Bolts,
 D1150 – 3/8" Lock Washers, 33136 – 3/8" Nylon Locknuts

Item No. 25 (Square to Round Weldments) are attached together using:

33229 – 3/8" x 1 1/4" Bolts,
 33136 – 3/8" Nylon Locknuts

PARTS LIST

STANDARD CORNER ASSEMBLY 50 & 60 H.P.

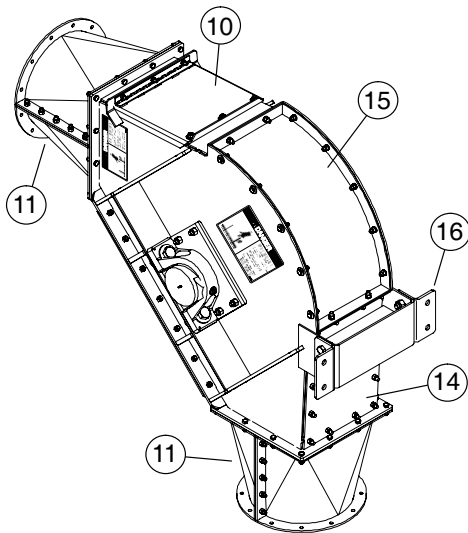
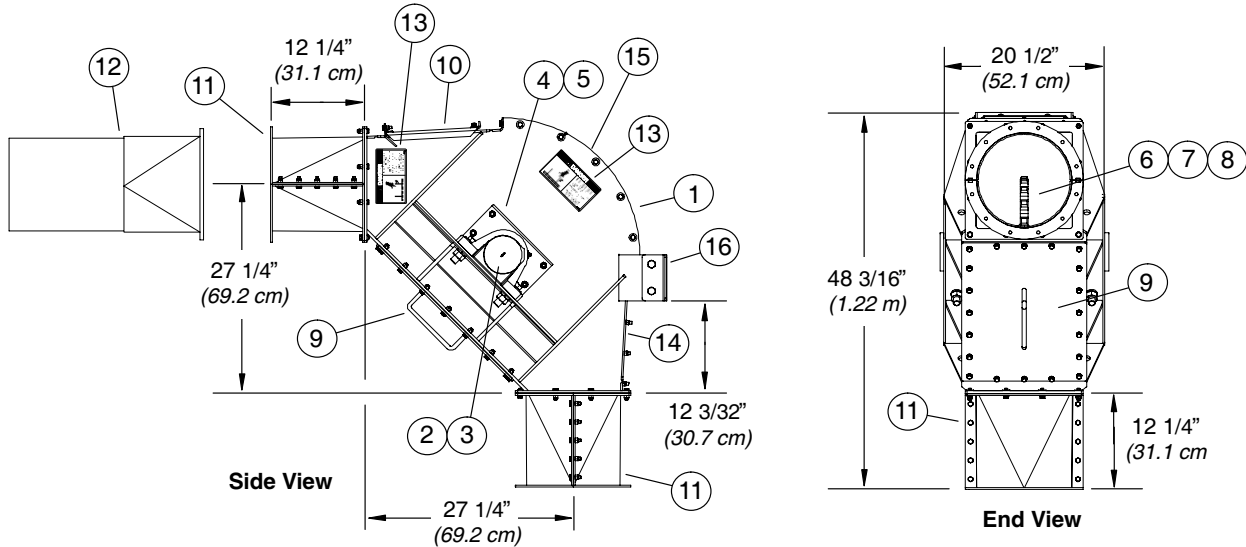

Ref. No.	Part No.	Description
1	1040739	Corner Weldment, 90°
2	1029505	Bearing, Pillow Block, 2 7/16"
3	1038084	Bearing Cap
4	1023299	Seal, f/ 2 15/16" Bearing
5	1038077	Seal Hold-Down
6	1039786	Sprocket, 22 tooth
7	1017144	Key, 7/8" sq, x 5" long
8	1023357	Shaft
9	1039288	Panel, Inside Cover
10	1023355	Door, Access
11	1039295	Square-to-Round, 12"
12	1039454	Tube Section w/ Flange
13	1012872	Decal, Danger Do Not Operate...
14	1039292	Plate, Bottom AR
15	1023314	Cover f/ Grain Pump Corner
16	1038083	Mounting Foot

Item No. 2 (Bearings) are attached using:
1017146 – 7/8" x 3 1/2" Bolts, D1231 – 7/8" Lock Washers, D1232 – 7/8" Non-Lock Nuts

Item No's. 4 & 5 (Seal & Hold-Down Plate) are attached using:
1002243 – 1/2" x 1 1/2" Carriage Bolts,
33138 – 1/2" Nylon Locknuts

Item No. 9 (Inside Cover Panel) is attached using:
33229 – 3/8" x 1 1/4" Bolts, D1150 – 3/8" Lock Washer,
D1149 – 3/8" Non-Lock Nut

Item No. 10 (Access Door) is attached using:
33046 – 5/16" x 1" Bolts, 33135 – 5/16" Nylon Locknuts,
33024 – 3/8" Flat Washers, D1150 – 3/8" Lock Washers,
D1149 – 3/8" Non-Lock Nuts

Item No. 11 (Square to Round Weldments) are attached together and to the Corner using:
33060 – 3/8" x 1" Bolts, 33229 – 3/8" x 1 1/4" Bolts,
D1150 – 3/8" Lock Washers, 33136 – 3/8" Nylon Locknuts

Item No. 14 (AR Plate) is attached using:
1001631 – 3/8" x 1" Bolts, 33133 – 3/8" Nylon Locknuts,

Item No. 15 (Cover) is attached using:
33229 – 3/8" x 1 1/4" Bolts, 33024 – 3/8" Flat Washer,
D1150 – 3/8" Lock Washer, D1149 – 3/8" Non-Lock Nut

Item No. 16 (Mounting Feet) are attached using:
33276 – 5/8" x 1 1/2" Bolts, 33139 – 5/8" Nylon Locknuts,

STANDARD CORNER ASSEMBLY

75 & 100 H.P.

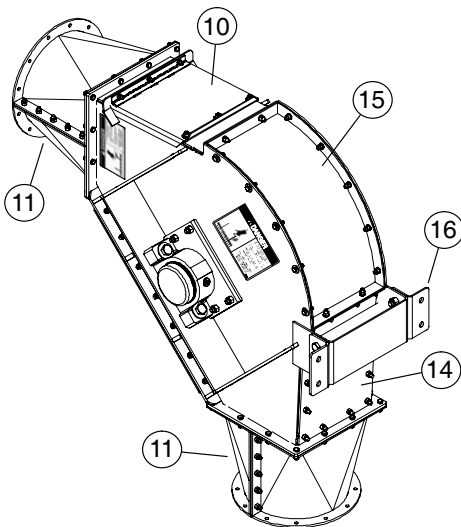
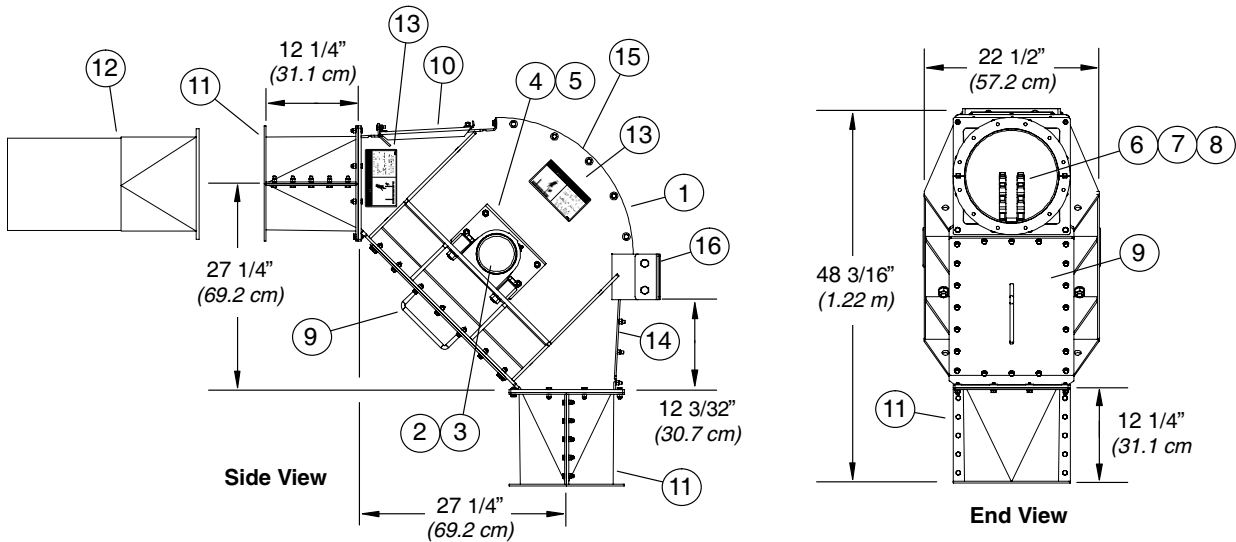

Ref. No.	Part No.	Description
1	1039279	Corner Weldment, 90°
2	1025681	Bearing, Pillow Block, 2 15/16"
3	1039337	Bearing Cap
4	1033618	Seal, f/ 2 15/16" Bearing
5	1039303	Seal Hold-Down
6	1039388	Sprocket, 22 tooth
7	1033623	Key, 1" sq, x 8" long
8	1039302	Shaft
9	1039288	Panel, Inside Cover
10	1023355	Door, Access
11	1039295	Square-to-Round, 12"
12	1039454	Tube Section w/ Flange
13	1012872	Decal, Danger Do Not Operate...
14	1039292	Plate, Bottom AR
15	1023314	Cover f/ Grain Pump Corner
16	1038083	Mounting Foot

Item No. 2 (Bearings) are attached using:
 1017146 – 7/8" x 3 1/2" Bolts, D1231 – 7/8" Lock Washers, D1232 – 7/8" Non-Lock Nuts

Item No's. 4 & 5 (Seal & Hold-Down Plate) are attached using:

1002243 – 1/2" x 1 1/2" Carriage Bolts,
 33138 – 1/2" Nylon Locknuts

Item No. 9 (Inside Cover Panel) is attached using:
 33229 – 3/8" x 1 1/4" Bolts, D1150 – 3/8" Lock Washer,
 D1149 – 3/8" Non-Lock Nut

Item No. 10 (Access Door) is attached using:
 33046 – 5/16" x 1" Bolts, 33135 – 5/16" Nylon Locknuts,
 33024 – 3/8" Flat Washers, D1150 – 3/8" Lock Washers,
 D1149 – 3/8" Non-Lock Nuts

Item No. 11 (Square to Round Weldments) are attached together and to the Corner using:
 33060 – 3/8" x 1" Bolts, 33229 – 3/8" x 1 1/4" Bolts,
 D1150 – 3/8" Lock Washers, 33136 – 3/8" Nylon Locknuts

Item No. 14 (AR Plate) is attached using:
 1001631 – 3/8" x 1" Bolts, 33133 – 3/8" Nylon Locknuts,

Item No. 15 (Cover) is attached using:
 33229 – 3/8" x 1 1/4" Bolts, 33024 – 3/8" Flat Washer,
 D1150 – 3/8" Lock Washer, D1149 – 3/8" Non-Lock Nut

Item No. 16 (Mounting Feet) are attached using:
 33276 – 5/8" x 1 1/2" Bolts, 33139 – 5/8" Nylon Locknuts,

PARTS LIST

90° DISCHARGE w/ GATE (DROP ASSEMBLY)

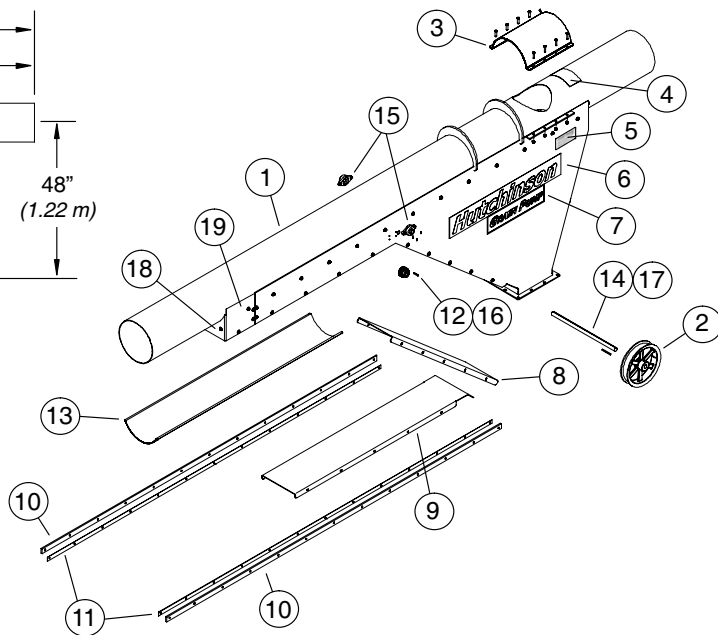
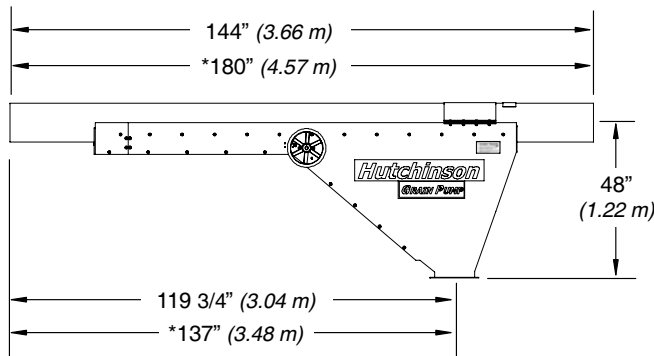

*For extended length drops

All items listed are used on both the 42" and 60" units unless otherwise noted.

The complete Drop Assembly can be obtained by ordering Part No's: 1033302-HS (42" Unit) and 1035809-HS (60" Unit). Complete assemblies include all items listed below.

Ref. No.	Part No.	Description	Ref. No.	Part No.	Description
1	1033298-HS	Drop Weldment, 90° f/ 42"	(10)	1039486	Rail, Gate Guide f/ 60"
(1)	1035810-HS	Drop Weldment, 90° f/ 60"	11	1038954	Shim, Gate Rail Guide f/ 42"
2	1034255	Wheel, Cable Control	(11)	1039488	Retainer, Gate Rail Guide f/ 60"
3	1023340	Cover, Inspection Hole	12	1023294	Spur Gear
4	1012872	Decal, Danger Do Not Operate...	13	1033288	Gate Weldment f/ 42"
5	1012785	Decal, Chain Travel	(13)	1035816	Gate Weldment f/ 60"
6	1001127	Decal, Hutchinson	14	1038990	Shaft
7	34349	Decal, Grain Pump	15	6818D	Bearing, 2-Hole Flange, 1"
8	1023344	Door, Access	16	8371C	Key, 1/4" sq. x 1 1/2" long
9	1038960	Door, Upper Access f/ 42"	17	4046A1	Key, 1/4" sq. x 3" long
(9)	1039483	Door, Upper Access f/ 60"	18	1039476	End Cover f/ 60"
10	1038948	Rail, Gate Guide f/ 42"	19	1039478	Side Panel Bracket f/ 60"

Item No. 3 (Hole Cover) is attached using:
33310 – 3/8" x 1 1/2" Bolts, 33136 – 3/8" Nylon Lock Nuts

Item No. 8 (Access Door) is attached using:
33046 – 5/16" x 1" Bolts, 33023 – 5/16" Flat Washers, 33135 – 5/16" Nylon Locknuts

Item No. 9 (Upper Access Door) is attached using:
33046 – 5/16" x 1" Bolts, 33023 – 5/16" Flat Washers, 33135 – 5/16" Nylon Locknuts

Item No's. 10 & 11 (Rail Guides) are attached using:
33046 – 5/16" x 1" Bolts, 33023 – 5/16" Flat Washers, 33144 – 5/16" Lock Washers

Item No. 15 (Bearings) are attached using:
33257 – 7/16" x 1 1/2" Bolts, 4533 – 7/16" Flat Washers 33137 – 7/16" Nylon Locknuts

Item No's. 18 & 19 (End Cover & Side Brackets) are attached using:
33046 – 5/16" x 1" Bolts, 33023 – 5/16" Flat Washers, 33135 – 5/16" Nylon Locknuts,

CHAIN & PADDLES ASSEMBLY (SINGLE STRAND & DOUBLE STRAND)

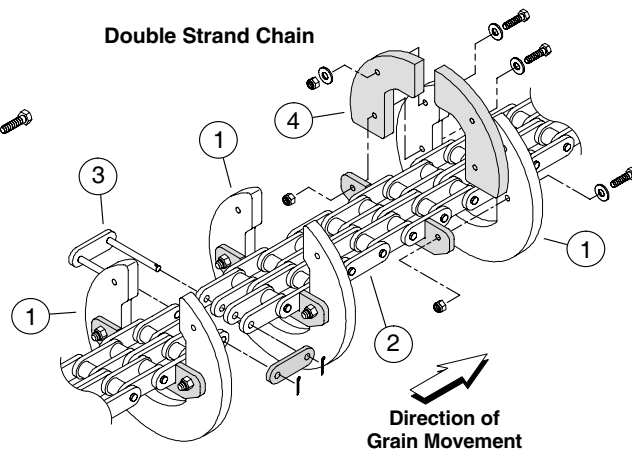
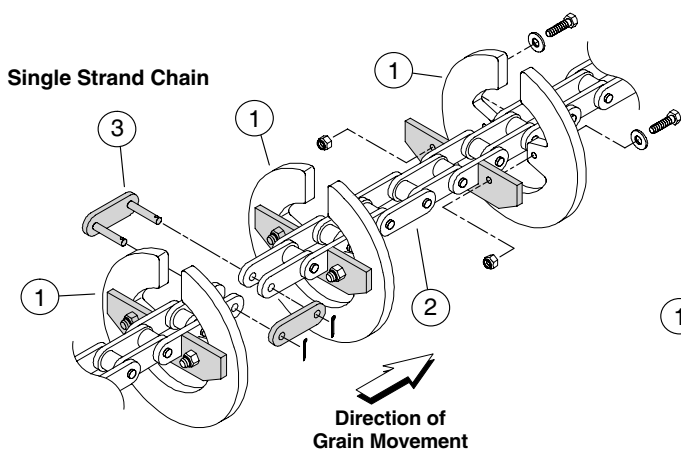

Ref. No.	Part No.	Description
1	1023056	Paddle, 1/2" UHMW f/ Single Strand Chain
(1)	1033224	Paddle, 1/2" UHMW f/ Double Strand Chain
2	1038008D	Chain, 81XHH, 125 7/32" long, 48 Pitch Single Strand
(2)	1039431	Chain, 81XHH, 125 7/32" long, 48 Pitch Double Strand
3	1017077D	Connecting Link f/ Single Strand
(3)	1031670	Connecting Link f/ Double Strand
4	1033614	Rubber Clean-Out for Double Strand Paddle

GROUND CONTROL WHEEL (w/ CABLE)

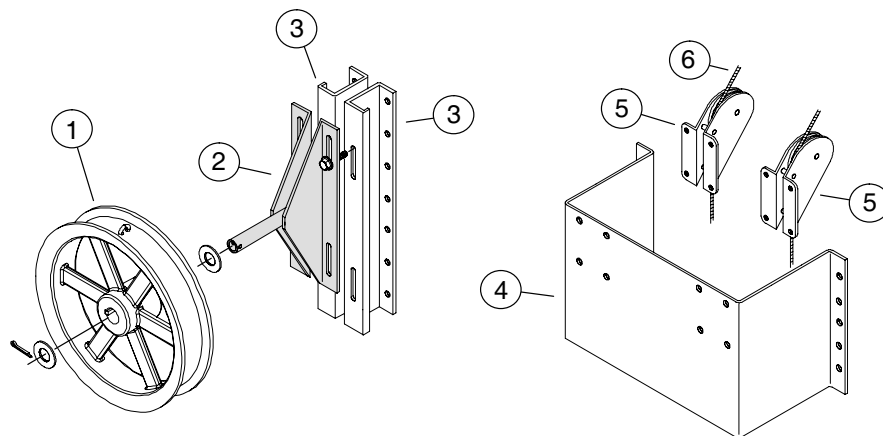

Ref. No.	Part No.	Description
1	1034255	Control Wheel, 2 9/16" wide
2	1011745	Bracket, Wheel Support
3	1011743	Plate, Binwall Mount

Ref. No.	Part No.	Description
4	1011742	Bracket, Upper Wall
5	1006876	Pulley, 2 1/2"
6	1025845	Cable, 1/4" dia. x 150' long

PARTS LIST

GROUND CONTROL WHEEL KIT (w/ CHAIN)

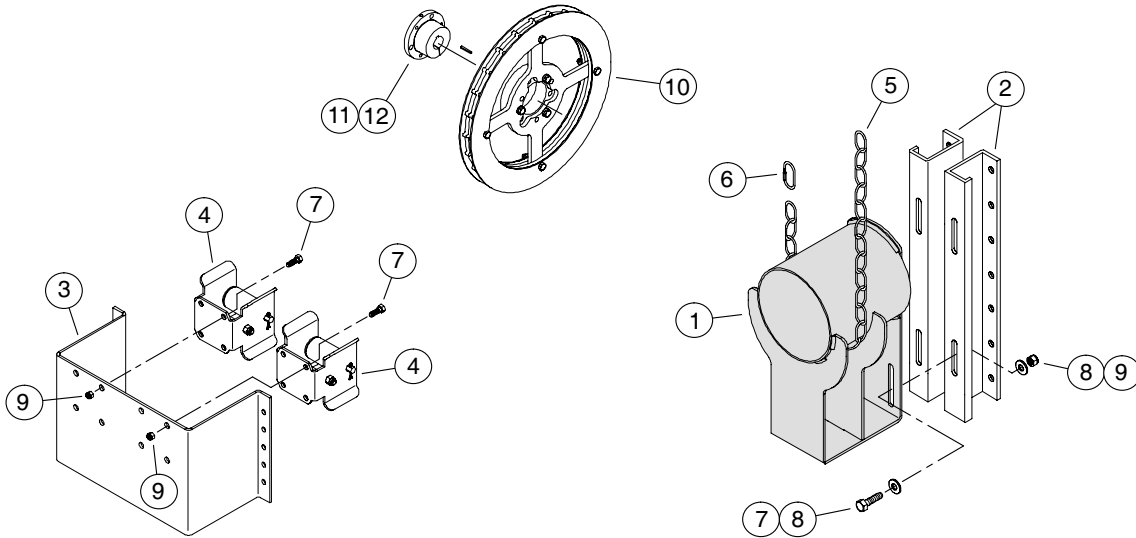

Ref. No.	Part No.	Description	Ref. No.	Part No.	Description
1	1042186	Mount, Lower Chain	7	33060	Bolt, 3/8-16 x 1" G5 PLT
2	1011743	Plate, Bin Wall Mount	8	33024	Washer, 3/8" Flat PLT
3	1042178	Bracket, Upper Wall	9	33136	Nut, 3/8-16 Nylon Lock PLT
4	1042174	Roller Assembly	10	1042153	Chain Wheel Ay. (Sprocket)
5	1042193	Chain, 3/16" x 120' long	11	1036838	Bushing, 1" SF QD
6	1042190	Coupler, Threaded Chain	12	4046A1	Key, 1/4" sq. x 3" long

INLET HOPPER

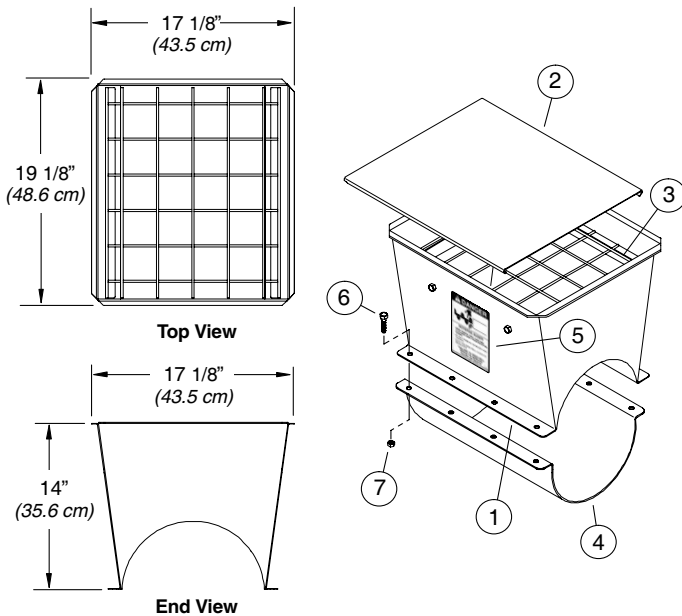

Complete Hopper Assembly, Part No. 60046A11

Ref. No.	Part No.	Description
1	60046A1	Inlet Hopper, 12"
2	2225A	Hopper Cover - Plain
3	1042387	Screen f/ 12" Hopper
4	2242C	Back Band, 12" x 18" long
5	1001985	Decal, Danger Rotating Auger
6	4736	Bolt, 5/16-18 x 1 1/2" G5 PLT
7	33151	Nut, 5/16-18 Non-Lock
--	1001128*	Decal, Hutchinson
--	1041833*	Decal, USA Flag

*Not Shown

CONNECTING BAND w/ INSPECTION PORT and CONNECTING BAND

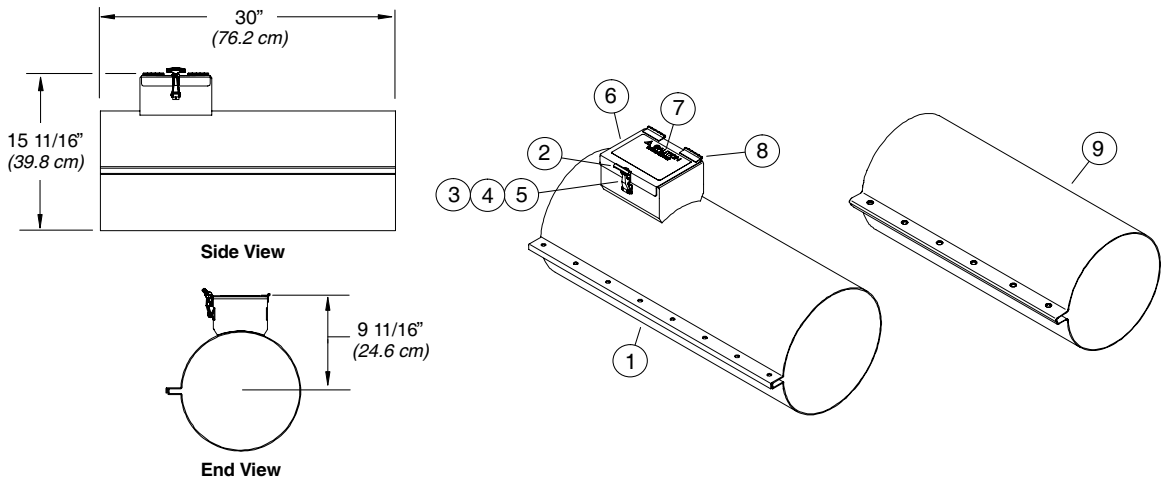

Ref. No.	Part No.	Description	Ref. No.	Part No.	Description
1	1032503	Connecting Band (12") w/ Inspection Port	5	11018273	Nut, #6 Non-Lock
2	1018308	Rubber Latch	6	1032479	Lid, Inspection Port
3	1018271	Screw, #6 x 3/8" Pan Head	7	1033033	Decal, Caution
4	1018272	Washer, #6 Lock	8	90038	Hinge
			9	1224D	Connecting Band, 12" x 30"

INSPECTION PORT

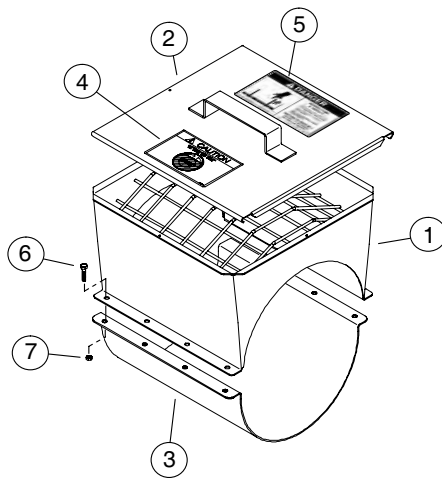
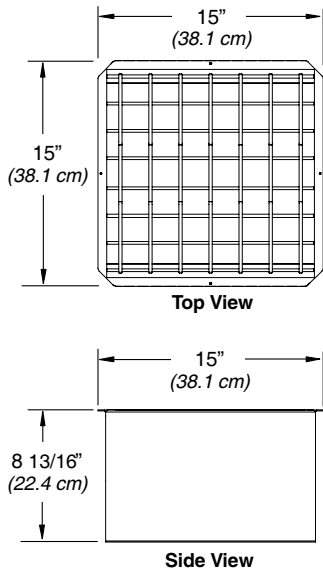

Ref. No.	Part No.	Description
1	11039492	Inspection Port w/ Screen
2	1039495	Cover Weldment
3	1034164	Back Band, 12" x 14"
4	1033033	Decal, Caution, Grain Fill
5	1012872	Decal, Danger, Do Not Operate...
6	4736	Bolt, 5/16-18 x 1 1/2"
7	33151	Nut, 5/16-18 Non-Lock

PARTS LIST

RACK & PINION CONTROL (MANUAL, 30" TRAVEL)

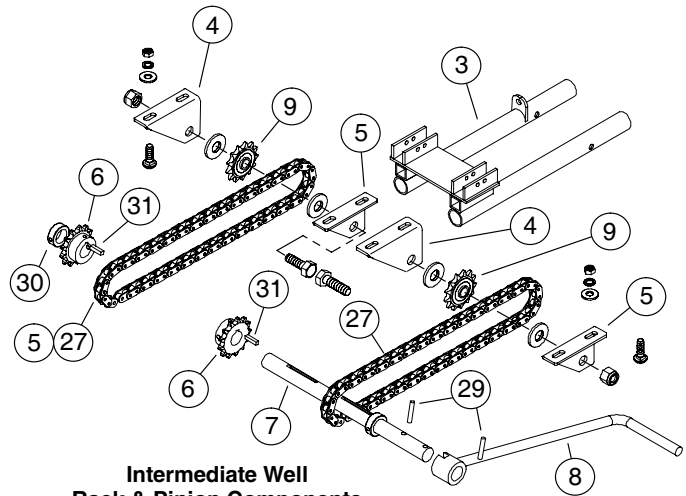
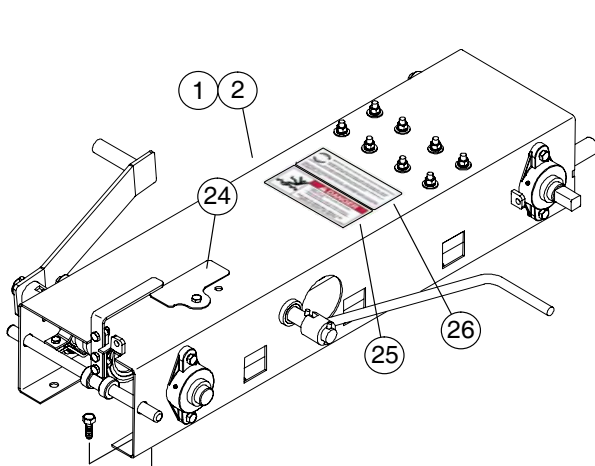

**Intermediate Well
Rack & Pinion Components**

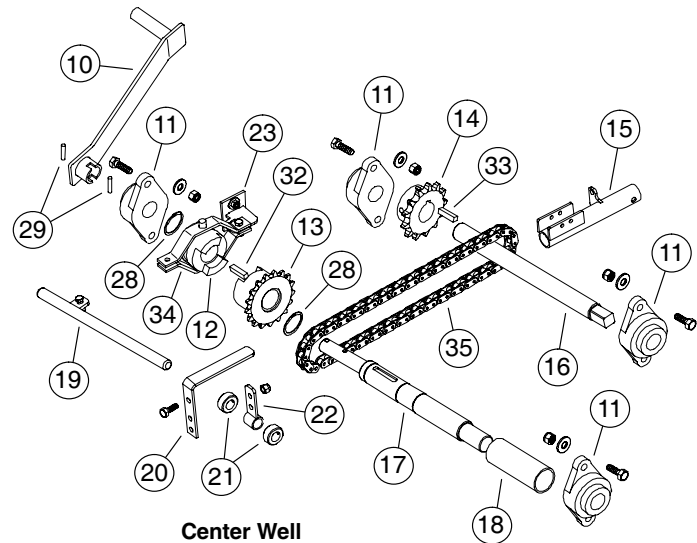
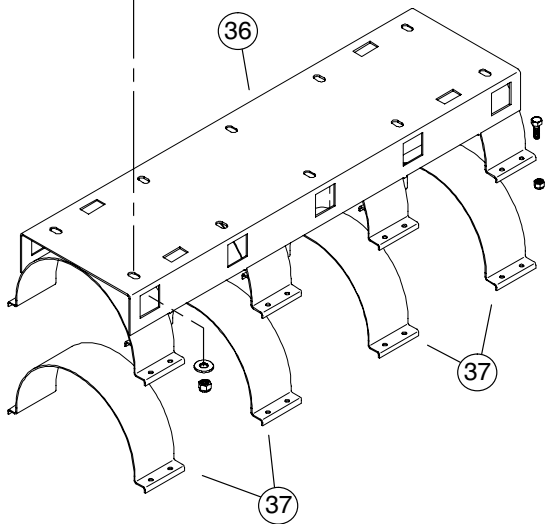

**Center Well
Rack & Pinion Components**

Item No. 1 (Rack & Pinion Assembly) is attached using:

- 33082 – 1/2" x 1 1/4" Bolts
- 33025 – 1/2" Flat Washer
- 33138 – 1/2" Nylon Lock Nut

Items No. 11 (Flange Bearings) are attached using:

- 1002202 – 7/16" x 1 1/4" Bolts
- 4533 – 7/16" Flat Washer
- 33137 – 7/16" Nylon Lock Nut

Items No. 4 & 5 (Idler Sprocket Bracket) are attached using:

- 1001631 – 3/8" x 1" Carriage Bolts
- D1150 – 3/8" Lock Washers
- D1149 – 3/8" Non-Lock Nuts
- 33024 – 3/8" Flat Washers

Item No. 20 (Upper Clutch Control Handle) is attached using:

- 33060 – 3/8" x 1" Bolts
- 33136 – 3/8" Nylon Lock Nut

Items No. 9 (Idler Sprockets) are attached using:

- 33244 – 5/8" x 2" Bolts
- 33026 – 5/8" Flat Washers
- 1005111 – 5/8" Side Depress Lock Nuts

Item No. 37 Half-Bands are attached using:

- 4727-1 – 5/16" x 1 1/4" Bolts
- 33135 – 5/16" Nylon Lock Nut

RACK & PINION CONTROL
(MANUAL, 30" TRAVEL)

Ref. No.	Part No.	Description	Ref. No.	Part No.	Description
1	1037928	Rack & Pinion Assembly (complete)	21	7307C	•Collar, 3/4" Set
2	1037798	•Housing, Rack & Pinion Mount	22	1037795	•Control, Lower Clutch
3	1037803	•Pipe, Intermediate Well Control	23	1037746	•Bracket, Clutch Control Pivot
4	1037826	•Bracket, Idler Sprocket (right)	24	1039535	•Cover, Access Hole
5	1037827	•Bracket, Idler Sprocket (left)	25	1002305	•Decal, Danger: Keep Out of Bin
6	5204H	•Sprocket, 50B 13, 1" bore	26	1006947	•Decal, Rack & Pinion Controls
7	1037801	•Shaft, R&P Intermediate Wells	27	1018576	•Chain, RC50 66 Pitch
8	1023962	•Handle f/ Intermediate Wells	- -	40023*	••Master Link f/ RC50 Chain
9	6821P	•Sprocket, Idler 50 13 5/8" bore	28	1025167	•Ring, 1 1/2" External Snap
10	1037935	•Handle f/ Center Well	29	6386C	•Roll Pin, 5/16" x 2" long
11	1029742D	•Bearing, 2-Bolt Flange 1 1/4"	30	3324A1	•Collar, 1" Set
12	1025090	•Sliding Jaw Clutch	31	4020A1	•Key, 1/4" sq. x 1" long
13	1025089	•Sprocket, Clutch Jaw	32	4049A1	•Key, 3/8" sq. x 1 1/2" long
14	40687	•Sprocket, 60B 17 1 1/4" bore	33	8371C	•Key, 1/4" sq. x 1 1/2" long
15	1037799	•Bracket f/ Center Well Pipe	34	1024985	•Bracket, Clutch Yoke
16	1037738	•Shaft f/ Center Well Drive	35	1037862	•Chain, RC-60 102 Pitch
17	1037929	•Shaft f/ Center Well	- -	42007*	••Master Link f/ RC 60 Chain
18	1037744	•Spacer f/ R&P Shaft	36	1039239	Base plate, R&P Mount
19	1037782	•Rod, Clutch Control	37	5271A1	Half Band, 4" Wide f/ 12" Tube
20	1037796	•Handle, Upper Clutch Control			

• Indented Parts Names Indicate these Parts are Included in the Previous Assembly.

*Not Shown

PARTS LIST

RACK & PINION CONTROL **(ELECTRIC, 30" TRAVEL)**

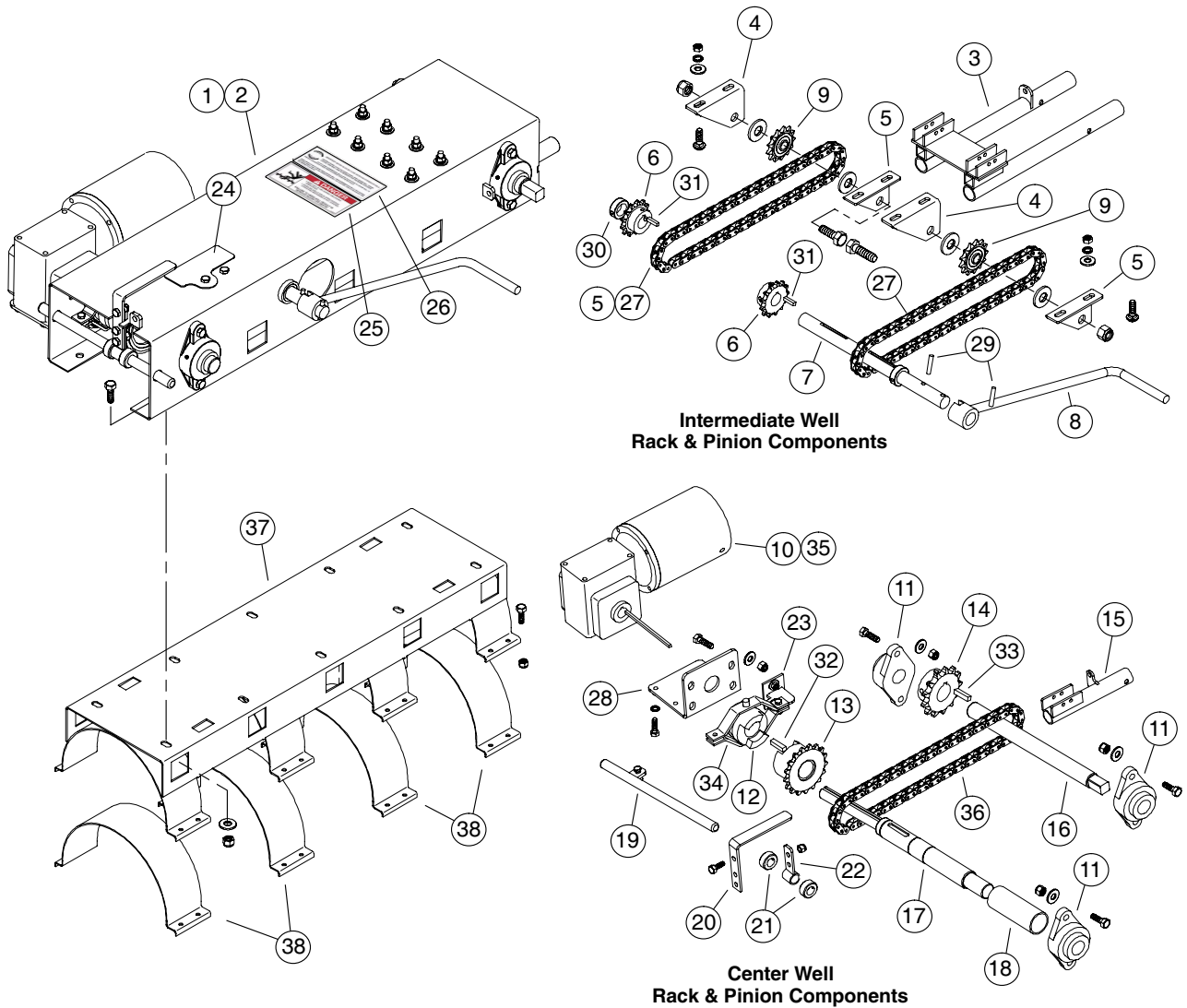

Item No. 1 (Rack & Pinion Assembly)
is attached using:
33082 – 1/2" x 1 1/4" Bolts
33025 – 1/2" Flat Washer
33138 – 1/2" Nylon Lock Nut

Item No. 10 (Gearbox)
is attached using:
33064 – 3/8" x 1" Bolts
D1150 – 3/8" Lock Washers

Item No. 28 (Motor Mount)
is attached using:
1002202 – 7/16" x 1 1/4" Bolts
4533 – 7/16" Flat Washer
33137 – 7/16" Nylon Lock Nut

Items No. 4 & 5 (Idler Sprocket Bracket)
are attached using:
1001631 – 3/8" x 1" Carriage Bolts
D1150 – 3/8" Lock Washers
D1149 – 3/8" Non-Lock Nuts
33024 – 3/8" Flat Washers

Items No. 11 (Flange Bearings)
are attached using:
1002202 – 7/16" x 1 1/4" Bolts
4533 – 7/16" Flat Washer
33137 – 7/16" Nylon Lock Nut

Item No. 38 Half-Bands
are attached using:
4727-1 – 5/16" x 1 1/4" Bolts
33135 – 5/16" Nylon Lock Nut

Items No. 9 (Idler Sprockets)
are attached using:
33244 – 5/8" x 2" Bolts
33026 – 5/8" Flat Washers
1005111 – 5/8" Side Depress Lock Nuts

Item No. 20 (Clutch Control Handle)
is attached using:
33060 – 3/8" x 1" Bolts
33136 – 3/8" Nylon Lock Nut

RACK & PINION CONTROL
(ELECTRIC, 30" TRAVEL)

Ref. No.	Part No.	Description	Ref. No.	Part No.	Description
1	1037832	Rack & Pinion Assembly (complete)	22	1037795	•Control, Lower Clutch
2	1037798	•Housing, Rack & Pinion Mount	23	1037746	•Bracket, Clutch Control Pivot
3	1037803	•Pipe, Intermediate Well Control	24	1039535	•Cover, Access Hole
4	1037826	•Bracket, Idler Sprocket (right)	25	1002305	•Decal, Danger: Keep Out of Bin
5	1037827	•Bracket, Idler Sprocket (left)	26	1006947	•Decal, Rack & Pinion Controls
6	5204H	•Sprocket, 50B 13, 1" bore	27	1018576	•Chain, RC50 66 Pitch
7	1037801	•Shaft, R&P Intermediate Wells	28	1036250	•Motor Mount
8	1023962	•Handle f/ Intermediate Wells	29	6386C	•Roll Pin, 5/16" x 2" long
9	6821P	•Sprocket, Idler 50 13 5/8" bore	30	3324A1	•Collar, 1" Set
10	1026527	•Motor, 1/2 H.P. 1 PH	31	4020A1	•Key, 1/4" sq. x 1" long
11	1029742D	•Bearing, 2-Bolt Flange 1 1/4"	32	4049A1	•Key, 3/8" sq. x 1 1/2" long
12	1025090	•Sliding Jaw Clutch	33	8371C	•Key, 1/4" sq. x 1 1/2" long
13	1025089	•Sprocket, Clutch Jaw	34	1024985	•Bracket, Clutch Yoke
14	40687	•Sprocket, 60B 17 1 1/4" bore	35	1023415	•Gearbox
15	1037799	•Bracket f/ Center Well Pipe	36	1037862	•Chain, RC-60 102 Pitch
16	1037738	•Shaft f/ Center Well Drive	--	1017007A*	•Limit Switch
17	1037733	•Shaft f/ Center Well	--	1038187*	•Bracket, Limit Switch Mounting
18	1037744	•Spacer f/ R&P Shaft	--	1039535*	•Stop Plate
19	1037782	•Rod, Clutch Control	37	1039239	Base plate, R&P Mount
20	1037796	•Handle, Upper Clutch Control	38	5271A1	Half Band, 4" Wide f/ 12" Tube
21	7307C	•Collar, 3/4" Set			

• Indented Parts Names Indicate these Parts are Included in the Previous Assembly.

*Not Shown

PARTS LIST

RACK & PINION CONTROL (STANDARD, 18" TRAVEL)

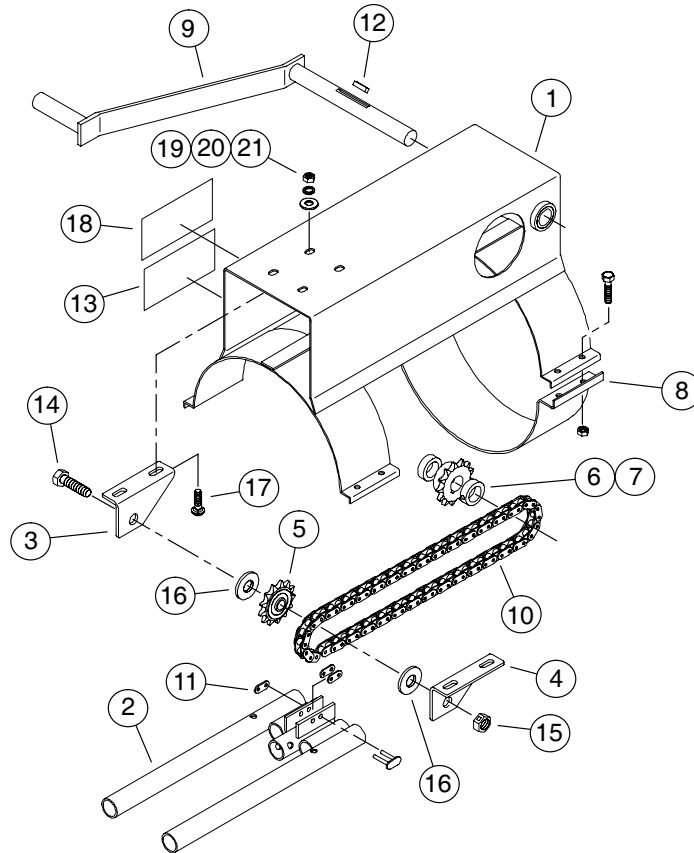

Ref. No.	Part No.	Description	Ref. No.	Part No.	Description
1	1025311	Housing, Rack & Pinion	12	4020A1	Key, 1/4" sq. x 1" long
2	61703	Tube Control	13	1002305	Decal, Danger: Keep Out of Bin
3	52327	Bracket, Idler Sprocket (L)	14	33244	Bolt, 5/8-11 x 2" G5 PLT
4	52326	Bracket, Idler Sprocket (R)	15	1005111	Nut, 5/8-11 Side Depress Lock
5	6821P	Sprocket, #50 13 tooth	16	33026	Washer, 5/8" Flat
6	5204H	Sprocket, Single #50 13T	17	1001631	Bolt, 3/8-16 x 1" Carriage
7	3324A1	Collar, 1" Set	18	1006947	Decal, R&P Instruction
8	5271A1	Half Band, 4" Wide f/ 12" Tube	19	D1149	Nut 3/8-16 PLT
9	61687	Handle f/ Rack & Pinion	20	D1150	Washer, 3/8" Lock
10	1018576	Chain, RC-50 66 Pitch	21	33024	Washer, 3/8" Flat
11	40023	Link, f/ RC-50 Chain			

CENTER BINWELL (SIDE INLET) f/ 12" COMMERCIAL GRAIN PUMP

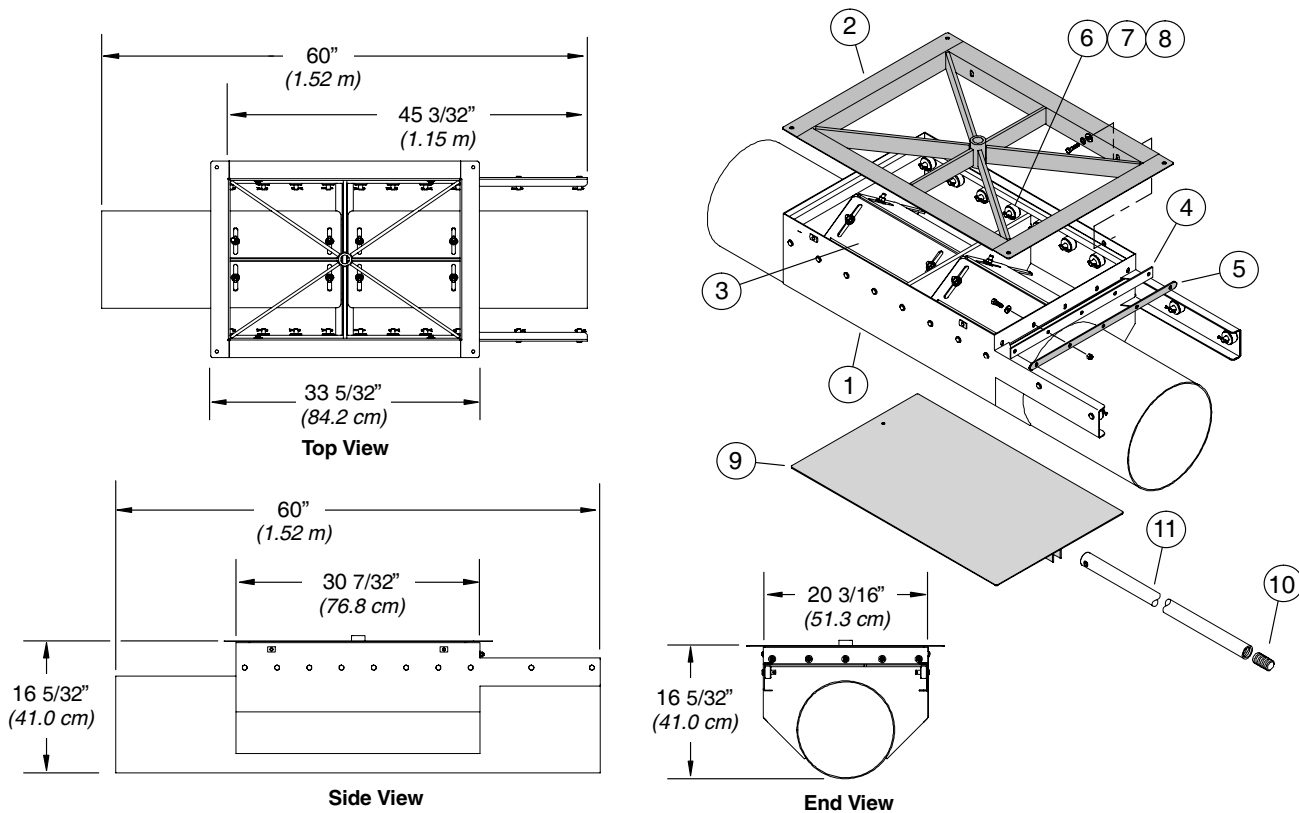

Item No. 2 (Flange Weldment) is attached using:
33309 – 3/8" x 3/4" Bolts, 33024 – 3/8" Flat Washers,
D1150 – 3/8" Lock Washers

Item No. 3 (Restrictor Plate) is attached using:
D1150 – 3/8" Lock Washers, 33024 – 3/8" Flat Washers,
D1149 – 3/8" Non-Lock Nuts

Item No's. 4 & 5 (Wiper Belt, Wiper Strap) are attached using:
33046 – 5/16" x 1" Bolts, 33023 – 5/16" Flat Washers,
33135 – 5/16" Nylon Locknuts

The Complete Center Binwell Assembly can be obtained by ordering Part No. 1039605. The complete assembly contains items 1 thru 9 listed below.

Ref. No.	Part No.	Description	Ref. No.	Part No.	Description
1	1039606	Center Binwell Inlet Weldment	6	51867	Wheel, Nylon, 1.475" O.D.
2	1037605	Flange f/ Center Binwell	7	33025	Washer, 1/2" Flat PLT
3	1039612	Plate, Restrictor	8	33161	Cotter Pin, 1/8" x 1" long
4	1037596	Wiper Belt f/ Center Binwell	9	1037601	Gate f/ Center Binwell
5	1037598	Strap, f/ Center Binwell Wiper			

For Items No. 10 & 11, Refer to Pages 20, 21 and 22 for Control Pipe Part No's. and Lengths.

PARTS LIST

INTERMEDIATE BINWELL **f/ 12" COMMERCIAL GRAIN PUMP**

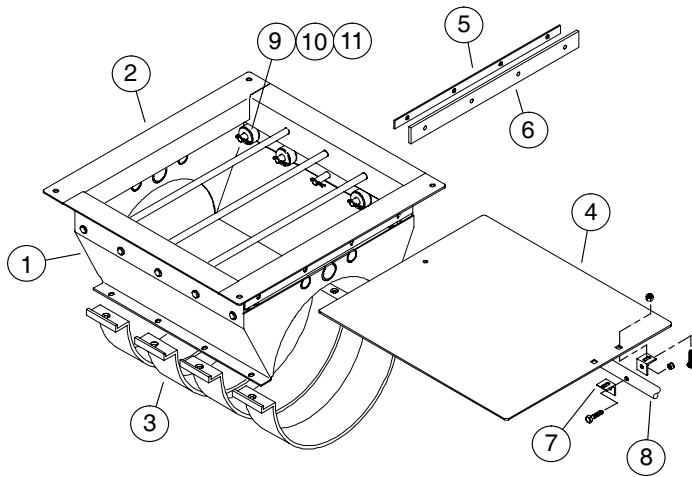
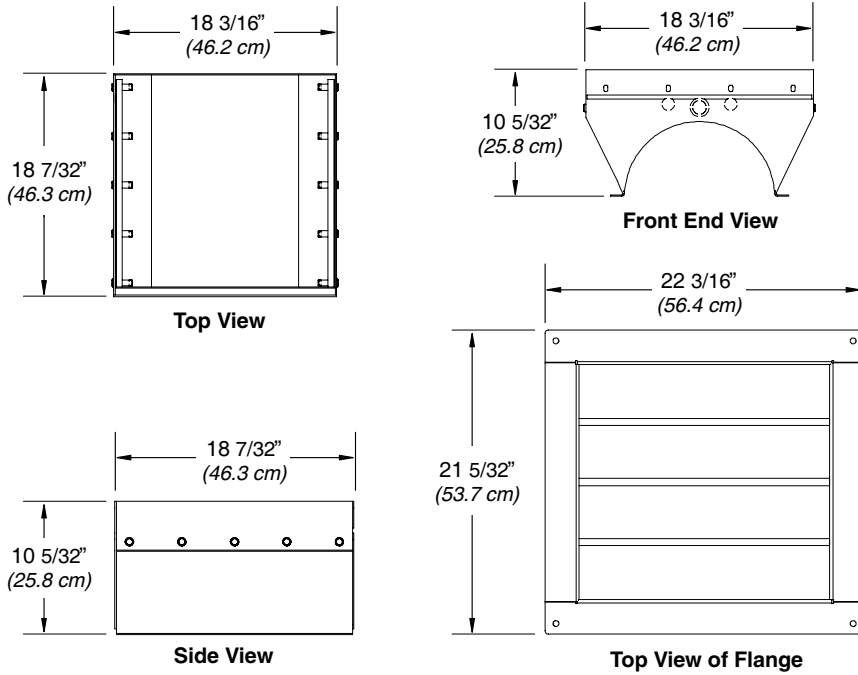

The Complete Intermediate Binwell Assembly can be obtained by ordering Part No. 1039259. The complete assembly contains items 1 thru 7 and 9 thru 11 listed below.

Ref. No.	Part No.	Description
1	1039258	Intermediate Binwell Weldment
2	1037821	Flange f/ Intermediate Binwell
3	5269A1	Half Band, 2" wide f/ 12" Tube
4	1037816	Gate f/ Intermediate Binwell
5	1037815	Strap f/ Binwell Wiper Belt
6	1037814	Wiper Belt f/ Binwell
7	1037817	Angle f/ Binwell Gate
8	- - -	Control Pipe*
9	51867	Wheel, 1.475" O.D. Nylon
10	33025	Washer, 1/2" Flat PLT
11	33161	Pin, Cotter, 1/8" x 1" long

Item No. 7 (Gate Angles) are attached using:
1002245 – 5/16" x 1" Carriage Bolts,
33135 – 5/16" Nylon Locknuts

Item No. 3 (Half Bands) are attached using:
4726 – 5/16" x 1 1/2" Bolts,
33151 – 5/16" Non-Lock Nuts

Item No's. 5 & 6 (Wiper Belt, Wiper Strap) are attached using:
33046 – 5/16" x 1" Bolts,
33023 – 5/16" Flat Washers,
33135 – 5/16" Nylon Locknuts

*For Item No. 8, Refer to Pages 20, 21 and 22 for Control Pipe Part No's. and Lengths.

CENTER BINWELL (STANDARD) f/ 12" GRAIN PUMP

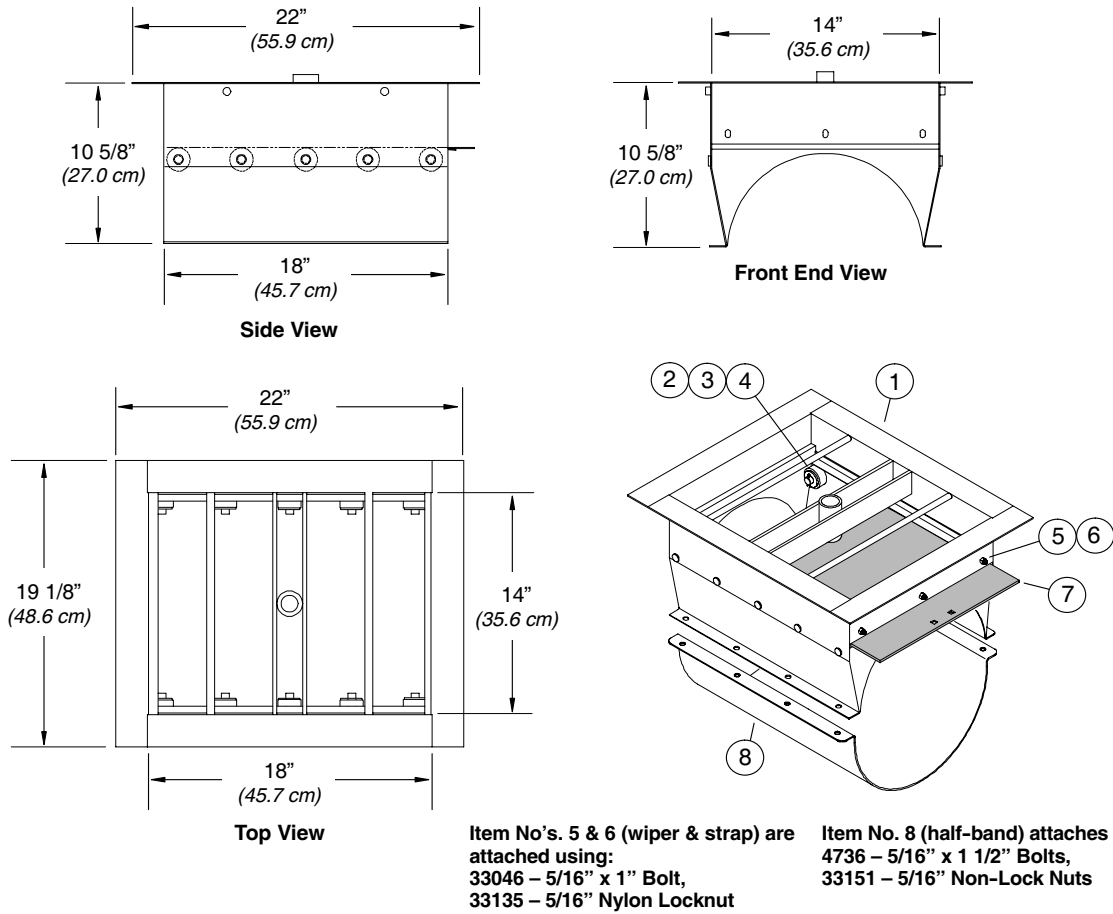

The complete Center Binwell Assembly can be obtained by ordering Part No. 1032831.

The complete assembly contains all items listed below.

Ref. No.	Part No.	Description	Ref. No.	Part No.	Description
1	1032827	Center Binwell Weldment	5	1032829	Wiper Belt f/ Center Binwell
2	51867	Wheel, 1.475" O.D. Nylon	6	1032830	Strap f/ Binwell Wiper Belt
3	33025	Washer, 1/2" Flat PLT	7	1032828	Gate f/ Center Binwell
4	33161	Pin, Cotter, 1/8" x 1" long	8	2242C	Back Band f/ 12" Tube

PARTS LIST

INTERMEDIATE BINWELL (STANDARD) **f/ 12" GRAIN PUMP**

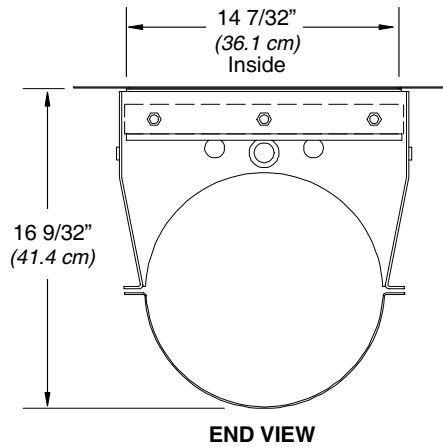
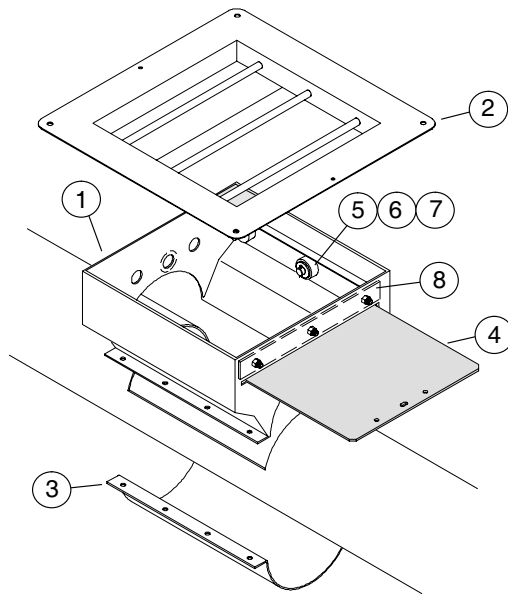
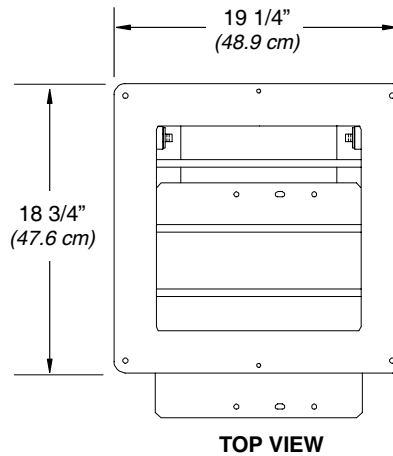
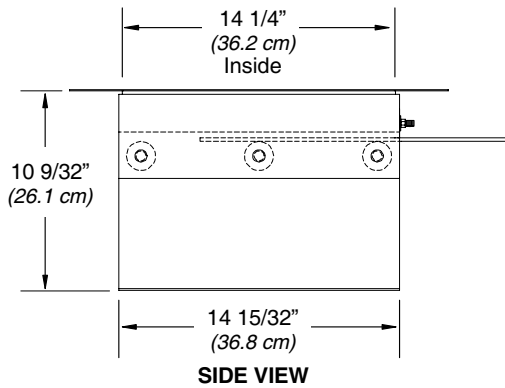

Item No. 3 (back band) attaches using:
4736 – 5/16" x 1 1/2" Bolts,
33151 – 5/16" Non-Lock Nuts

Item No's. 8 (wiper) is attached using:
33046 – 5/16" x 1" Bolt, 33135 – 5/16" Nylon Locknut,
33023 – 5/16" Flat Washer

The complete Intermediate Binwell Assembly can be obtained by ordering Part No. 1029878. The complete assembly contains items listed below.

Ref. No.	Part No.	Description	Ref. No.	Part No.	Description
1	1029877	Intermediate Binwell Weldment	5	51867	Wheel, 1.475" O.D. Nylon
2	1029176	Flange f/ Intermediate Binwell	6	33025	Washer, 1/2" Flat
3	1029873	Back Band f/ 12" Tube	7	33161	Pin, Cotter, 1/8" x 1" long
4	1029212	Slide Gate f/ Intermediate Binwell	8	1029208	Wiper f/ Intermediate Binwell

DUMP HOPPERS

2 GRATE, 5 GRATE & 6 GRATE

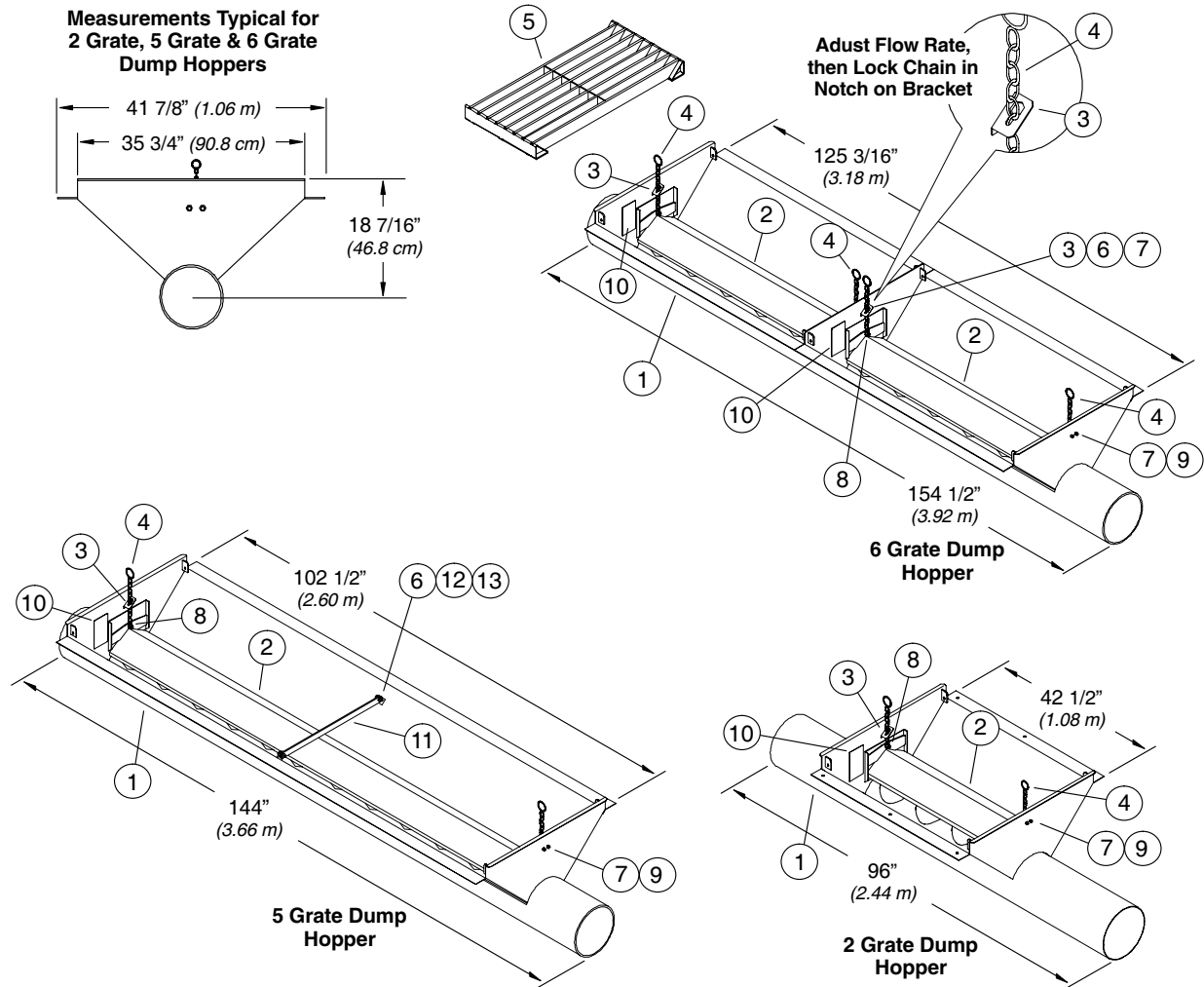

All items listed below are used for the 2-grate, 5-grate & 6-grate hoppers unless noted otherwise.

Ref. No.	Part No.	Description	Ref. No.	Part No.	Description
1	1025401	Drive Over Hopper (2 grate)	6	33046	Bolt, 5/16-18 x 1" PLT
(1)	1026646	Drive Over Hopper (5 grate)	7	33135	Nut, 5/16-18 Nylon Lock PLT
(1)	1023791	Drive Over Hopper (6 grate)	8	33136	Nut, 3/8-16 Nylon Lock PLT
2	1025402	Gate, Flow Control (2 grate)	9	4701-1	Bolt, 5/16-18 x 3/4" PLT
(2)	1026644	Gate, Flow Control (5 grate)	10	1002310	Decal, Danger: Do Not Operate...
(2)	1023384	Gate, Flow Control (6 grate)	11	1012959	Support Bar f/ 5 Grate Hopper
3	1012669	Bracket, Chain	12	33151	Nut, 5/16-18 Non-Lock PLT
4	1012466	Chain, Flow Adjustment	13	33144	Washer, 5/16" Lock PLT
5	1038431	Grate f/ Drive Over Hopper			

The complete hopper assembly's can be obtained by ordering Part No's.

1025400 - 2 Grate; 1026645 - 5 Grate and 1023790 - 6 Grate.

The complete hopper assembly's include all items listed above.

PARTS LIST

DUMP HOPPER (7 GRATE) w/ ELECTRIC RACK & PINION GATES

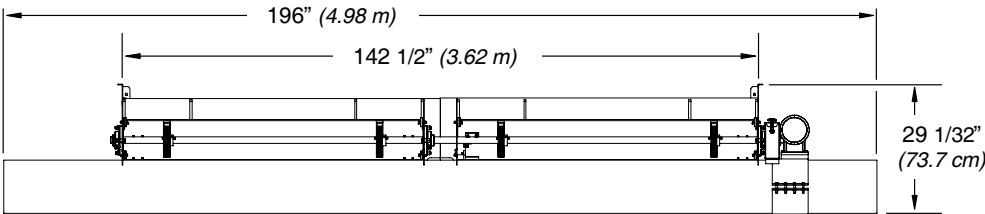
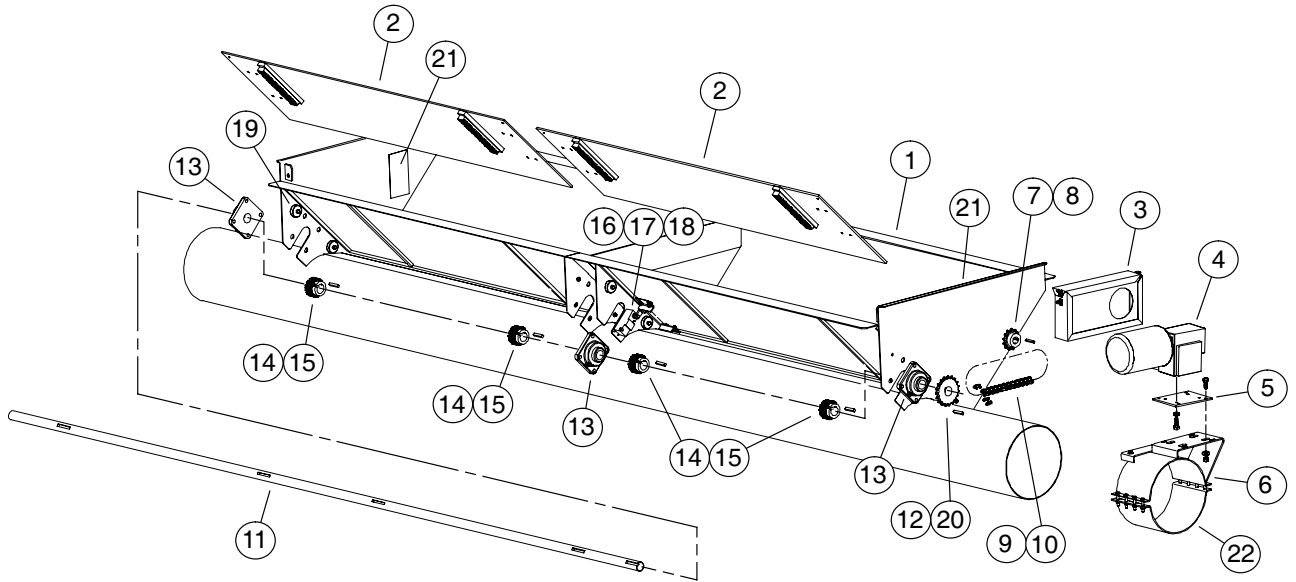

Side View

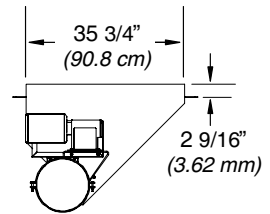

End View

Item No. 3 (Chain Guard) is attached using:
4701-1 – 5/16" x 3/4" Bolts, 33023 – 5/16" Flat Washers,
33144 – 5/16" Lock Washers

Item No. 4 (Motor) is attached to Item No. 5 using:
33060 – 3/8" x 1" Bolts, D1150 – 3/8" Lock Washers

Item No. 5 (Mount Plate) is attached to Item No. 6 using:
33229 – 3/8" x 1 1/4" Bolts, 33024 – 3/8" Flat Washers,
33136 – 3/8" Nylon Locknuts

Items No. 13 (Bearings) are attached using:
33247 – 1/2" x 1 3/4" Bolts, 33025 – 1/2" Flat Washers,
33138 – 1/2" Nylon Locknuts

Item No. 16 (Limit Switch) is attached using:
1017092 – 3/16" x 1 1/2" Stove Bolts,
33021 – 3/16" Flat Washers, 33142 – 3/16" Lock Washers,
33149 – 3/16" Non-Lock Nuts

Item No. 17 (Limit Switch Stop Bracket) is attached using:
33022 – 1/4" Flat Washers, 4003 – 1/4" Nylon Locknuts

Item No. 19 (Skate Wheel) is attached using:
4736 – 5/16 x 1 1/2" Bolt, 33135 – 5/16" Nylon Locknut

Item No. 22 (Half Band) is attached using:
1002199 – 3/8" x 2" Bolts, D1149 – 3/8" Non-Lock Nuts

DUMP HOPPER (7 GRATE) w/ ELECTRIC RACK & PINION GATES

The complete hopper assembly can be obtained by ordering Part No's.
1035857, 1035857EP, 1035857-601, 1035857-601EP

The complete hopper assembly includes all items listed below.

Ref. No.	Part No.	Description	Ref. No.	Part No.	Description
1	1035856	Hopper, 7 Grate Dump	11	1034139	Pinion Shaft f/ 7 Grate Dump Hopper
2	1035869	Gate f/ 7 Grate Dump Hopper	12	41069	Sprocket, 60B 19 tooth
3	1032364	Guard, Chain	13	1010A	Bearing, 4-Hole Flange, 1 1/2"
4	1014757	Motor, 1/2 H.P. 108-230V	14	1016854	Spur Gear, S822 x 1 1/2" KW&SS
(4)	1017557	Motor, 1/2 H.P. 108-230V Exp. Proof	15	1038D	Key, 3/8" sq. x 2" long
(4)	1017558	Motor, 1/2 H.P. 60 hz 1 ph	16	1017007A	Limit Switch
(4)	1017559	Motor, 1/2 H.P. 60 hz 1 ph Exp. Proof	17	1017199	Lever Arm f/ Limit Switch
5	1017507	Plate, Motor Mounting	18	1034155	Bracket, Limit Switch Stop
6	1033261	Band f/ Motor Mount	19	1016845	Skate Wheel
7	1034145	Sprocket, 60B 13 tooth	20	4049A1	Key, 3/8" sq. x 1 1/2" long
8	5169B1	Key, 1/4" sq. x 1 1/4" long	21	1002310	Decal, Danger: Cover Missing
9	40975	Chain, RC-60 50 pitch	22	1017955	Half Band, 8" Wide f/ 12" Tube
10	- - -	•Connecting Link f/ RC-60 Chain			

• Indented Parts Names Indicate these Parts
are Included in the Previous Assembly.

PARTS LIST

TRUCK DUMP HOPPER (2 GRATE) w/ ELECTRIC RACK & PINION GATE

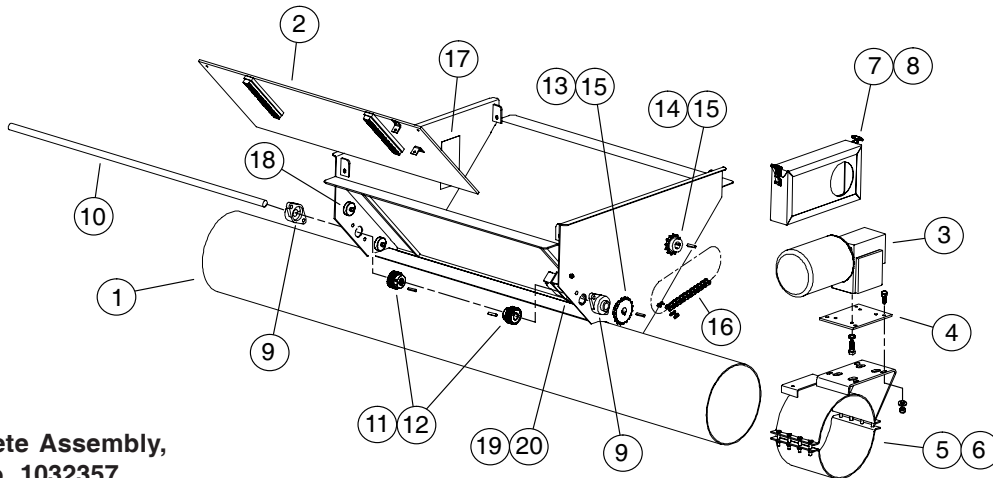
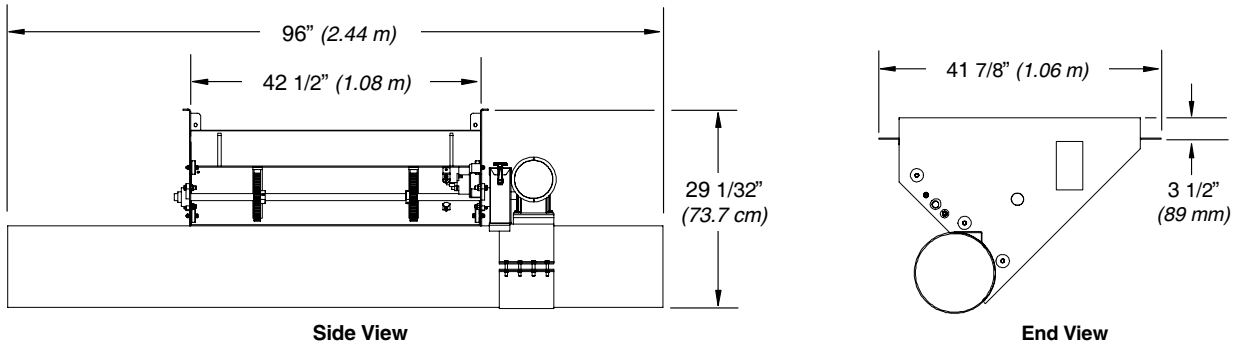

**Complete Assembly,
Part No. 1032357**

Item No. 3 (Motor) is attached to Item No. 4 using:
33060 – 3/8" x 1" Bolts, D1150 – 3/8" Lock Washers

Item No. 4 (Mount Plate) is attached to Item No. 5 using:
33229 – 3/8" x 1 1/4" Bolts, 33024 – 3/8" Flat Washers,
33136 – 3/8" Nylon Locknuts

Item No. 6 (Half Band) is attached using:
1002199 – 3/8" x 2" Bolts,
D1149 – 3/8" Non-Lock Nuts

Item No. 7 (Chain Guard) is attached using:
4701-1 – 5/16" x 3/4" Bolts, 33023 – 5/16" Flat Washers,
33144 – 5/16" Lock Washers

Item No. 9 (Bearings) are attached using:
33257 – 7/16" x 1 1/2" Bolts, 4533 – 7/16" Flat Washers,
33137 – 7/16" Nylon Locknuts

Item No. 18 (Skate Wheel) is attached using:
4736 – 5/16 x 1 1/2" Bolt, 33135 – 5/16" Nylon Locknut

Item No. 19 (Limit Switch) is attached using:
1017092 – 3/16" x 1 1/2" Stove Bolts,
33142 – 3/16" Lock Washers, 33149 – 3/16" Non-Lock Nuts

Item No. 20 (Limit Switch Arm Lever) is attached using:
33015 – 1/4" x 1 1/4" Elevator Bolts,
33150 – 1/4" Non-Lock Nuts

Ref. No.	Part No.	Description
1	1032344	Dump Hopper Weldment
2	1032359	Gate f/ 2-Grate Dump Hopper
3	1017457	Motor, 1/2 H.P. 208-230/460V
4	1017507	Plate, Motor Mount
5	1032361	Band, Motor Mounting
6	1017955	Half Band, 8" Wide f/ 12" Tube
7	1032364	Chain Guard
8	1018308	Rubber Latch
9	6818D	Bearing, 2-Hole Flange 1"
10	1032362	Shaft, Pinion

Ref. No.	Part No.	Description
11	1023967	Spur Gear, 22 tooth
12	8371C	Key, 1/4" sq. x 1 1/2" long
13	6360G	Sprocket, 19 tooth 1" bore
14	1017456	Sprocket, 13 tooth 1 1/8" bore
15	1020A1	Key, 1/4" sq. x 1" long
16	99032530	Chain, RC-50 42 pitch w/ link
17	1002310	Decal, Danger: Missing Cover
18	1016845	Skate Wheel
19	1017007	Limit Switch
20	1017199	Arm, Limit Switch Lever

FLAT STORAGE WELL w/ ELECTRIC SLIDE GATE

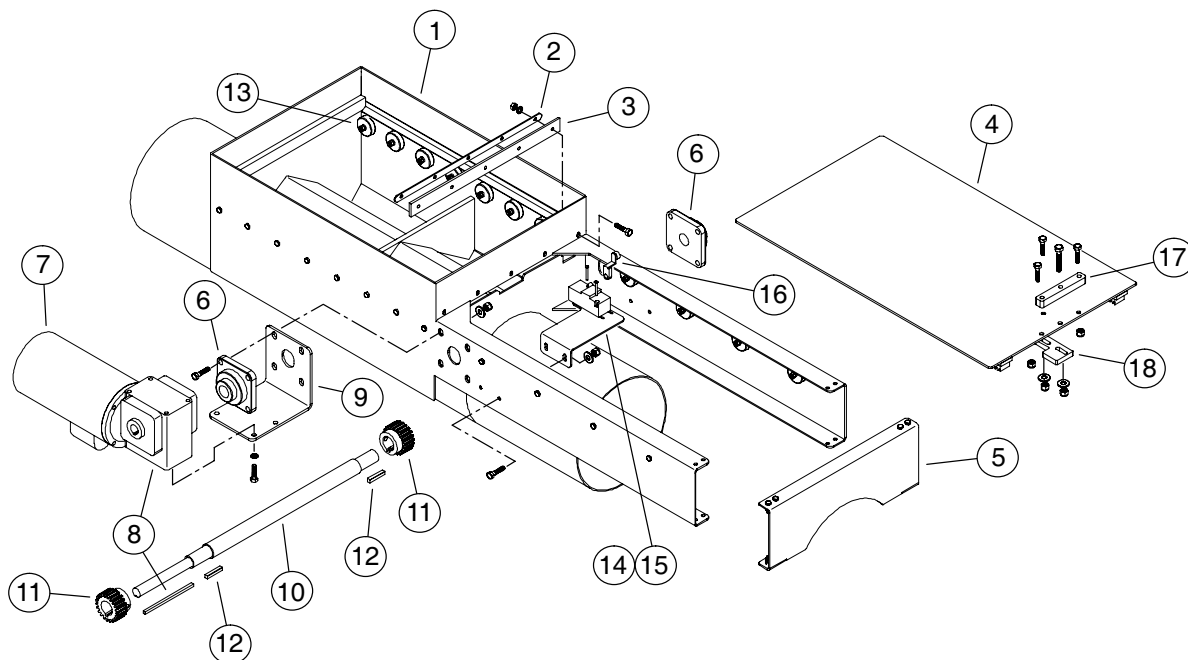

Item No's. 2 & 3 (Wiper & Strap) are attached using:
33046 – 5/16" x 1" Bolts, 33144 – 5/16" Lock Washers,
33151 – 5/16" Non-Lock Nuts

Item No. 5 (End Panel) is attached using:
33046 – 5/16" x 1" Bolts, 33135 – 5/16" Nylon Locknuts

Item No's. 6 & 9 (Bearings & Mount) are attached using:
33247 – 1/2" x 1 3/4" Bolts, 1002227 – 1/2" x 1 1/2" Bolts,
33138 – 1/2" Nylon Locknuts

Item No. 8 (Gearbox) is attached to Item 9 using:
33060 – 3/8" x 1" Bolts, D1150 – 3/8" Lock Washers

Item No. 13 (Skate Wheel) is attached using:
33135 – 5/16" Nylon Locknut

Item No. 14 (Limit Switch) is attached using:
1017092 – 3/16" x 1 1/2" Stove Bolts, 33021 – Flat Washers
33142 – 3/16" Lock Washers, 33149 – 3/16" Non-Lock Nuts

Item No. 15 (Limit Switch Mount Plate) is attached using:
33046 – 5/16" x 1" Bolts, 33023 – 5/16" Flat Washers,
33135 – 5/16" Nylon Locknuts

Item No's. 17 & 18 (Gate Stops) are attached using:
33310 – 3/8" x 1 1/2" Bolts, D1174 – 3/8" x 2 1/4" Bolt
33024 – 3/8" Flat Washers, 33136 – 3/8" Nylon Locknuts

Ref. No.	Part No.	Description
1	1040783	Flat Storage Well Weldment
2	1037598	Strap f/ Wiper Belt
3	1037596	Wiper Belt f/ Flat Storage Well
4	1040793	Gate f/ Flat Storage Well
5	1040807	End Panel
6	8370C	Bearing, 4-Hole Flange 1 1/4"
7	1026526	Motor, 1/2 H.P., 3 PH
(7)	1026527	Motor, 1/2 H.P., 1 PH
(7)	1026528	Motor, 1/2 H.P., 3 PH EXP
(7)	1026529	Motor, 1/2 H.P., 1 PH EXP
8	1023415	Gearbox w/ Key

Ref. No.	Part No.	Description
9	1040809	Mount Plate f/ Gearbox
10	1040792	Shaft, Pinion f/ Flat Storage Well
11	1016854	Spur Gear, S822 x 1.50" KW&SS
12	1038D	Key, 3/8" sq. x 2" long
13	1016845	Skate Wheel f/ Flat Storage Well
14	1017007	Limit Switch
15	1041074	Mount Plate f/ Limit Switch
16	1017199	Arm Lever f/ Limit Switch
17	1041103	Gate Stop f/ Flat Storage Well
18	1041075	Gate Stop, Closed Position

The complete Flat Storage Well assembly can be obtained by ordering Part No's.
1040782, 1040782EP, 1040782-460, 1040782-460EP
The complete well assembly includes all items listed above.

PARTS LIST

CHAIN MAINTENANCE ACCESS HOPPER 3' & 5' LONG HORIZONTAL

3' Assembly

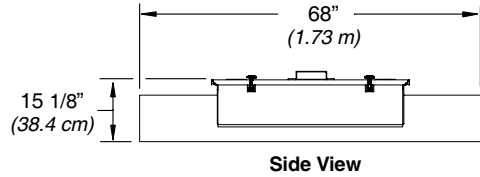
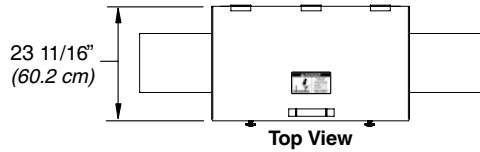

Item No. 3 (Screen Weldment) is attached using:
33229 – 3/8-16 x 1 1/4" Bolts,
D1150 – 3/8" Lock Washers
D1149 – 3/8" Non-Lock Nuts

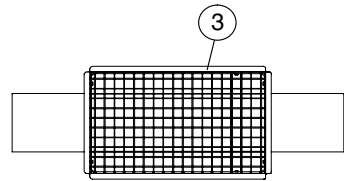

Cover Removed to Show Screen Detail

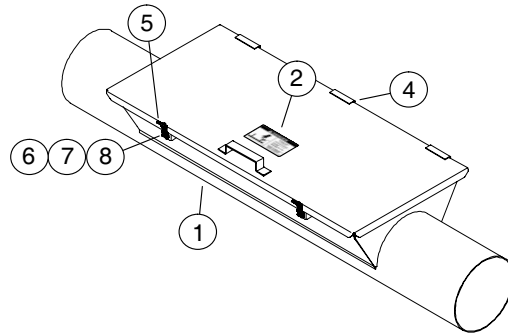

5' Assembly

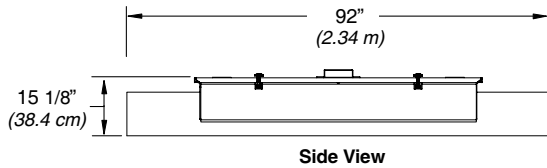
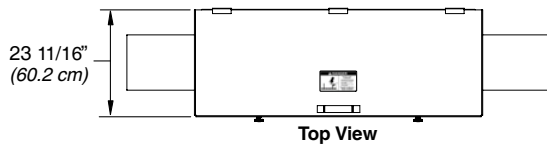

Item No. 3 (Screen Weldment) is attached using:
33229 – 3/8-16 x 1 1/4" Bolts,
D1150 – 3/8" Lock Washers
D1149 – 3/8" Non-Lock Nuts

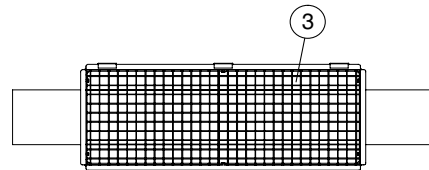

Cover Removed to Show Screen Detail

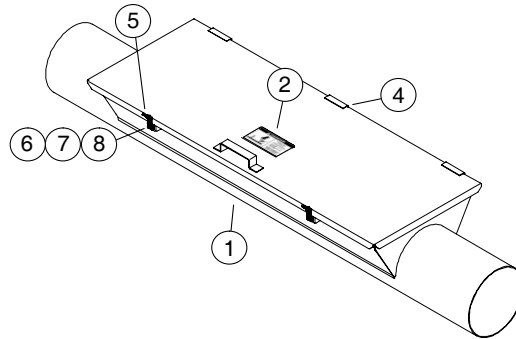

All items listed below are used for both the
3' & 5' Chain Access unless noted otherwise.

Complete Assembly f/ 3' Long - Part No. 1044225

Complete Assembly f/ 5' Long - Part No. 1039499

Ref. No.	Part No.	Description	Ref. No.	Part No.	Description
1	1044226	Chain Access Weldment f/ 3'	4	4000A1	Hinge, 1/4" pin x 4" long
(1)	1039500	Chain Access Weldment f/ 5'	5	1018308	Rubber Latch f/ Chain Access
2	1012872	Decal, Danger: Do Not Operate..	6	1018271	Bolt, #6 x 3/8" PPH, PLT
3	1044222	Screen f/ 3' Chain Access	7	1018272	Washer, #6 Lock PLT
(3)	1039507	Screen f/ 5' Chain Access	8	1018273	Nut, #6 Non-Lock PLT



Hutchinson/Mayrath

A Division of GLOBAL Industries Inc.

Hutchinson/Mayrath • P.O. Box 629 • Clay Center, KS. 67432
Ph. 785-632-2161 • Fx. 785-632-5964 • Toll Free 800-523-6993
www.hutchinson-mayrath.com