

**25° BIN UNLOADERS
6" to 6", 6" to 8",
8" to 8", 8" to 10" and 10" to 12"**

**OWNER'S & OPERATOR'S
MANUAL**

Effective February 12, 2002

Publication No. 1022176

THIS MANUAL IS FOR UNITS WITH SERIAL NUMBERS OF 903151 OR HIGHER.



Hutchinson/Mayrath

A Division of **GLOBAL** Industries, Inc.

P.O. Box 629 • 514 W. Crawford • Clay Center, KS 67432
Phone 785-632-2161 • 1-800-523-6993 • FAX 785-632-5964



Hutchinson/Mayrath

A Division of **GLOBAL Industries, Inc.**

POLICIES AND PROCEDURES

- PRICES:** Prices in effect at time of shipment will apply. Prices are subject to change without notice. All prices are F.O.B. Clay Center, Kansas. Orders shipped from locations other than Clay Center, Kansas will be subject to additional charges, such as back freight and/or additional freight.
- SERVICE CHARGE:** A service charge will be assessed on all past due balances as permitted by state law not to exceed 1-1/2% per month.
- MINIMUM ORDER:** Processing and handling costs necessitate a minimum charge of \$15.00 net on all orders.
- BACK ORDERS:** Back orders will be shipped as they become available. Contact Hutchinson/Mayrath Customer Service for alternative shipping options or if cancellation is desired.
- DAMAGED GOODS:** It is the consignee's responsibility to check all shipments thoroughly upon receipt of goods. If any damage is discovered, it must be noted on the freight bill of lading before signing. The consignee must make necessary claims against the respective freight line. All damage claims must be submitted within 30 days of delivery receipt.
- SHORTAGES:** All shortages must be noted at time of delivery receipt. Shortages must be noted on the freight bill of lading before signing. Hutchinson/Mayrath must be advised of all concealed shortages upon discovery. Once notified of concealed shortages Hutchinson/Mayrath will advise corrective action to be taken.
- RETURN OF GOODS:** All returns must be approved by Hutchinson/Mayrath prior to shipment. All return requests will be issued a return authorization number. **NO RETURNS WILL BE ACCEPTED WITHOUT A RETURN AUTHORIZATION NUMBER AND PRIOR AUTHORIZATION FROM THE FACTORY.** All returns must be shipped prepaid. A 15% restocking charge will be applied to all returned merchandise. Custom Products may not be returned for credit. Only current products in new and salable condition may be returned. No safety devices may be returned for credit.
- MODIFICATIONS:** It is the policy of Hutchinson/Mayrath to improve its product whenever possible and practical to do so. We reserve the right to make changes, improvements and modifications at any time without incurring the obligation to make such changes, improvements and modifications on any equipment sold previously.
- LIMITED WARRANTY:**
- (a) For a period of (1) year after receipt of goods by the original consumer buyer, Hutchinson/Mayrath will supply free of charge replacement parts for parts that prove defective in workmanship or material. Defective parts must be returned freight prepaid to a specified Hutchinson/Mayrath location. Only Hutchinson/Mayrath original repair parts may be used for warranty repairs.
 - (b) This limited warranty does not extend to parts designed to wear in normal operation and be replaced periodically; or to damage caused by negligence, accident, abuse or improper installation or operation.
 - (c) **GOODS NOT MANUFACTURED BY HUTCHINSON/MAYRATH CARRY ONLY THE MANUFACTURER'S WARRANTY.**
 - (d) **THIS UNDERTAKING IS IN LIEU OF ALL OTHER WARRANTIES, EXPRESSED OR IMPLIED, INCLUDING MERCHANTABILITY AND FITNESS FOR A PARTICULAR PURPOSE.**
- FAILURE TO FOLLOW THE INSTRUCTIONS CONTAINED IN THE OWNER'S & OPERATOR'S MANUALS AND THE ITEMS LISTED BELOW WILL RESULT IN THE VOIDING OF THIS LIMITED WARRANTY.**
- 1) Improper assembly, including failure to properly install all safety equipment.
 - 2) Improper installation (power & wiring included).
 - 3) Unauthorized alterations of goods.
 - 4) Goods operated when obviously in need of repair.
 - 5) Use of unauthorized repair parts.
 - 6) Irresponsible operation.
 - 7) Used to handle materials other than free flowing, non-abrasive and dry materials, as intended.
 - 8) Damaged through abusive use or accident.
- LIMITATION OF LIABILITY:** BUYER AGREES THAT IN NO EVENT SHALL HUTCHINSON/MAYRATH HAVE LIABILITY FOR DIRECT DAMAGES IN EXCESS OF THE CONTRACT PRICE OF THE GOODS IN RESPECT OF WHICH CLAIM IS MADE. BUYER FURTHER AGREES THAT IN NO EVENT SHALL HUTCHINSON/MAYRATH ON ANY CLAIM OF ANY KIND HAVE LIABILITY FOR LOSS OF USE, LOSS OF PROFITS, OR FOR ANY INDIRECT, INCIDENTAL OR CONSEQUENTIAL DAMAGES.

GENERAL SAFETY STATEMENT

This manual was written with the safety of the operator and others who work with the equipment as our prime concern. The instructions presented will help the reader learn SAFE day to day work practices. We want you as our partner in safety.

It is your responsibility as an owner, operator or supervisor to know what specific safety requirements and precautions exist and to make these known to all other personnel working with the equipment or in the area, so that they too may safely perform their duties and avoid any potentially hazardous situations.

Please remember safety equipment provides important protection for persons around a grain handling system that is in operation. Be sure that ALL safety shields and protection devices are installed and properly maintained. If any shields or guards are damaged or missing, contact your dealer to obtain the correct items.

Avoid any alterations of the equipment. Such alterations may create a dangerous situation where serious injury or death may occur.

SAFETY ALERT SYMBOL

The symbol shown below is used to call your attention to instructions concerning your personal safety. Watch this symbol - it points out important safety precautions. It means "ATTENTION! Become alert! Your personal safety is involved!" Read the message that follows and be alert to the possibility of personal injury or death.



BE ALERT! YOUR SAFETY IS INVOLVED.

WARNING



Anyone who will operate or work around this machine shall first read this manual! This manual must be delivered with the equipment to its owner. Failure to read this manual and its safety instructions is a misuse of the equipment.

TABLE OF CONTENTS

General Safety Statements	1
Safety Alert Symbol	1
Operator Qualifications	3
Sign-off Sheet	3
Machine Inspection	3
Designated Work Area	4
Operating Procedures	4-8
Electric Motor Drive Information	4-5
Flight Speed Information	5
Start-up	6
Break-in Information	6
Full Load Operation	7
Shutdown	7
Lockout	7
Clean-up	7
Trouble Shooting	8
Assembly Instructions	8-14
Safety Signs	P-1
Parts List	P-2 thru P-15

SERIAL NUMBER

To ensure efficient and prompt service, please furnish us with the model and serial number of your auger in all correspondence or other contact. (See page P-1.)

OPERATOR QUALIFICATIONS

Operation of this auger shall be limited to competent and experienced persons. In addition, anyone who will operate or work with this system must use good common sense. In order to be qualified, they must also know and meet all other requirements, such as:

1. Some regulations specify that no one under the age of 16 may operate power machinery. This includes augers. It is your responsibility to know what these regulations are in your own area or situation.
2. Current OSHA regulations state in part: "At the time of initial assignment and at least annually thereafter, the employer shall instruct every employee in the safe operation and servicing of all equipment with which the employee is, or will be involved."*
3. Unqualified persons are to stay out of the work area.
4. A person who has not read and understood all operating and safety instructions is not qualified to operate the machine.

*Federal Occupational Safety & Health Standards for Agriculture Subpart D, Section 1928.57 (a)(6).

SIGN OFF SHEET

As a requirement of OSHA it is necessary for the employer to train the employee in the safe operation and safety procedures of this auger. We include this sign off sheet for your convenience and personal record keeping.

DATE	EMPLOYER SIGNATURE	EMPLOYEE SIGNATURE

MACHINE INSPECTION

After delivery of your new auger and/or completion of assembly and before each use, inspection of the machine is mandatory. This inspection should include, but not be limited to:

1. Check to see that all guards listed in the assembly instructions are in place and secured and functional.
2. Check all safety signs and replace any that are worn, missing or illegible. They are listed in the parts section. Safety signs may be obtained from your Dealer or ordered from the factory.
3. Are all fasteners tight?

DESIGNATED WORK AREA

Before starting the auger, a designated work area should be established around it.

Under no circumstances should persons not involved in the operation be allowed to trespass into the work area.



It shall be the duty of all operators to see that children and/or other persons stay out of the work area! Trespass into the work area by anyone not involved in the actual operation shall result in an immediate shutdown by the operator.

It shall be the responsibility of all operators to see that the work area has secure footing, is clean and free of all debris, and tools which might cause accidental tripping and/or falling.

OPERATING INSTRUCTIONS

The 25° unloading kit includes a section of flanged tubing (with flight and stubs) which bolts to the flange on the unloading tube. The motor is mounted on top of the flanged tube. All mounts are designed to take the proper size motor. On direct belt drive units, the head bearing is sealed and self-aligning and drive parts include auger sheave and "B" belts for dependable service.

Our augers are well made and we are proud of our line of equipment. We would like you, as our customer, to do your part in using caution and good judgement in using our equipment, as well as any other machinery.



DO NOT enter the grain bin unless all power driven equipment has been shut down and locked out.

ELECTRIC MOTOR DRIVES

Always use a motor with required H.P. suggested in the chart on page 5. Use a motor that operates at 1750 RPM. Electric motors and controls shall be installed by a qualified electrician and must meet the standards set by the National Electrical Code and all local and state codes.

A magnetic starter should be used to protect your motor when starting and stopping. It should stop the motor in case of power interruption, conductor fault, low voltage, circuit interruption or motor overload. Then the motor must be restarted manually. Some motors have built-in thermal overload protection. If this type motor is used, use only those with manual reset.

Reset and motor starting controls must be located so that the operator has full view of the entire operation.



A main power disconnect switch capable of being locked only in the OFF position shall be provided. This shall be locked whenever work is being done on the Horizontal Bin Unloading Auger.

The horsepower recommendations are based on clean, dry shelled corn or wheat. High moisture grain (above 15%) will require greater power. The maximum possible capacity will be less with high moisture grain than with dry grain. Use chart on next page to determine size of motor required.

OPERATING INSTRUCTIONS - CONT.

ELECTRIC MOTOR DRIVES - CONT.

HORSEPOWER REQUIREMENTS

Use the Horsepower Chart according to length of Horizontal Unloading Flight used.

USED WITH STANDARD BIN WELL							USED WITH POWER SWEEP UNITS						
BIN DIA.	All 6"		All 8"		10" Commercial		BIN DIA.	All 6"		All 8"		10" Commercial	
	LENGTH	H.P.	LENGTH	H.P.	LENGTH	H.P.		LENGTH	H.P.	LENGTH	H.P.	LENGTH	H.P.
14'-16'	8'-9"	2	8'-10"	3	--	--	15'	10'-0 3/4"	3	10'-0 3/4"	5	--	--
17'-19'	10'-9"	2	10'-10"	3	--	--	18'	12'-0 3/4"	3	12'-0 3/4"	5	--	--
20'-22'	11'-9"	3	11'-10"	5	--	--	21'	13'-0 3/4"	5	13'-0 3/4"	5	--	--
23'-25'	13'-3"	3	13'-4"	5	13'-6"	7 1/2	24'	14'-6 3/4"	5	14'-6 3/4"	5	14'-6 3/4"	10
26'-28'	14'-9"	3	14'-10"	5	15'-0"	7 1/2	27'	16'-0 3/4"	5	16'-0 3/4"	5	16'-0 3/4"	10
29'-31'	16'-3"	3	16'-4"	7 1/2	16'-6"	7 1/2	30'	17'-6 3/4"	5	17'-6 3/4"	7 1/2	17'-6 3/4"	10
32'-34'	18'-3"	3	18'-4"	7 1/2	18'-6"	7 1/2	33'	19'-0 3/4"	5	19'-0 3/4"	7 1/2	19'-0 3/4"	10
35'-37'	19'-3"	3	19'-4"	7 1/2	19'-6"	7 1/2	36'	20'-6 3/4"	7 1/2	20'-6 3/4"	7 1/2	20'-6 3/4"	10

USED WITH COMMERCIAL BIN WELL & TUBES

BIN DIA.	All 8"		10" Commercial		BIN DIA.	All 8"		10" Commercial	
	FLIGHT LENGTH	H.P.*	FLIGHT LENGTH	H.P.		FLIGHT LENGTH	H.P.	FLIGHT LENGTH	H.P.
24'	14'-6"	5	14'-6"	7 1/2	48' & 49'	27'-0"	7 1/2	27'-0"	10
27'	16'-0"	5	16'-0"	7 1/2	54' & 55'	30'-0"	7 1/2	30'-0"	10
30'	17'-6"	5	17'-6"	7 1/2	60'	33'-0"	7 1/2	33'-0"	15
33' & 34'	19'-6"	5	19'-6"	7 1/2	63'	34'-6"	7 1/2	34'-6"	15
36'	20'-6"	7 1/2	20'-6"	7 1/2	68'-69'	37'-6"	10	37'-6"	15
37' & 39'	22'-0"	7 1/2	22'-0"	10	72'	39'-0"	10	39'-0"	15
40'	23'-0"	7 1/2	23'-0"	10	75'	40'-6"	10	40'-6"	15
42'	24'-0"	7 1/2	24'-0"	10					

FLIGHT SPEED INFORMATION

Proper auger flight speed is important for efficient operation of the auger.

1. If the flight speed is too fast, excessive wear will result. (See chart below.)
2. If the flight speed is too slow and the auger flighting is permitted to "load-up", high torque will be required to turn the auger flighting, and damage to the auger can result. Use the bin well slide gate to control the amount of grain fed into the unloading tube. (See chart below.)



**Disconnect power before resetting motor overloads.
Make certain electric motor is grounded.**

Model	*Motor Pulley Dia.	Driven Pulley Dia.	Recomm. Auger Speed	Max. Auger Speed	Min. Auger Speed
6" to 6" 6" to 8" 8" to 8"	3.5	12	510	700	450
8" to 10"	3.5	15	408	500	325
10" to 12"	3.0	15	350	400	225

*Motor pulleys are not furnished with the auger.

OPERATING INSTRUCTIONS - CONT.

START-UP INFORMATION

Make certain everyone is clear before operating equipment.

The operator shall be aware of any unusual vibrations, noises and the loosening of any fasteners.



Keep all safety shields and devices in place.

Keep hands, feet and clothing away from moving parts.

Shut off and lock out power to adjust, service or clean.

Start the electric motor that operates the auger. Open the slide gate in the center bin well to allow grain flow into the unloading auger. **Do not** overload the motor by opening the slide gate too far.

During the operation of the auger, one person shall be in a position to monitor the operation. Inspect the drive before adding power and know how to shut down in an emergency. (See page 7.) Visually inspect the auger periodically during operation.

BREAK-IN INFORMATION

Any screw conveyor when it is new or after it sets idle for a season should go through a "break-in" period.

The auger should be run at partial capacity until the screw becomes polished and smooth before attempting full capacity. A failure will most likely occur when run full before it has "polished up". It is recommended that several hundred bushels of grain be augered at partial capacity.

Never operate the auger when empty for any length of time, as excessive wear will result. If at all possible do not stop or start the auger under load, especially before the flight and tube become well polished, as this may cause the auger to "freeze-up".

1. If the flight speed is in excess of what is recommended, excessive wear will result.
2. If the flight speed is slow and the auger flighting is permitted to "load up", high torque will be required to turn the auger flighting and damage to the auger can result. Use the bin well slide gate to control the amount of grain fed into the auger.

OPERATING CAPACITIES

The results or capacities of screw conveyors or augers can vary greatly under varying conditions. Different materials, moisture content, amount of foreign matter, methods of feeding and speed all play a role in the performance of the auger. Twenty-five (25%) moisture could cut capacity back by as much as 40% under some conditions.

OPERATING INSTRUCTIONS - CONT.

FULL LOAD OPERATION



Observe work area restrictions.

Make certain everyone is clear before operating equipment.

TO START AUGER

1. Start electric motor before conveying grain.

NORMAL OPERATION

1. Open the slide gate in the center bin well until full load. It is unlikely the slide gate can be opened fully without overloading the auger. Always close the slide gate to allow the auger to empty before stopping.
2. Remove all the grain that will flow into the center bin well before opening any intermediate wells.

TO STOP AUGER

1. Close the slide gate to allow the auger to empty before stopping.
2. Shut off electric motor and lockout.

SHUTDOWN

A. NORMAL SHUTDOWN

Make certain that the bin well slide gates are closed to permit the unloading tube to clean out before stopping the unit. Before the operator leaves the work area, the power source shall be locked out.

B. EMERGENCY SHUTDOWN

Should the auger be immediately shutdown under load - disconnect and lockout the power source. Close the bin wells.

NOTE: Starting the unit under load may result in damage to the auger. Such damage is considered abuse of the equipment.

Reconnect power source and clear auger gradually.



Whenever you must service or adjust your equipment, make sure to stop motor and lockout your power source!

LOCKOUT

If the operator must leave the work area, or whenever servicing or adjusting, the horizontal bin unloading auger must be stopped and the power source turned off. Precaution should be made to prevent anyone from operating the auger when the operator is absent from the work area.

IMPORTANT: Use a main power disconnect switch capable of being locked only in the off position.

CLEAN-UP

1. Check to see that all guards listed in the assembly instructions are in place and secured and functional.
2. Check all safety signs and replace any that are worn, missing or illegible. The safety signs are listed in the parts section of this manual. Safety signs may be obtained from your Hutchinson dealer or ordered from the factory.
3. Are all fasteners tight?

OPERATING INSTRUCTIONS - CONT.

TROUBLE SHOOTING

AUGER VIBRATION

Driving belt may be over tightened, putting head stub and flight in a bind. Damage can occur to the auger fighting, thus causing noise. Damage usually occurs because of foreign material having been run through the auger. It may be necessary to remove the fighting for inspection.

LOW CAPACITY

The auger may not be getting enough grain. Check to make sure the bin well slide gate is open.

Check auger speed. Speeds slower than the recommended speed will result in low capacity.

AUGER PLUGS

The auger may be getting too much grain, causing "jamming" inside the housing.

The motor may be too small or wired improperly. (See HP requirements, page 5.)

If wet grain or other hard-to-move material is being augered, use the next larger size motor than recommended for normal use.

Is the auger free of any foreign material, such as sacks, tarp corners, etc? A plug of the discharge end will cause an auger plug.

ASSEMBLY INSTRUCTIONS

BEARING, U-JOINT & BEARING CONNECTION STUB FOR 8", 10" & 12" 25° UNLOADERS

On 6" 25° unloaders, the flight, hanger bearings, u-joint and bearing stub are pre-assembled at the factory. On 8", 10" & 12" 25° unloaders, the hanger bearing assembly and bearing connecting stub have not been factory assembled. This is so that they can be easily field adapted to work with either a standard bin unload system or a power sweep bin unload system by simply using the appropriate connecting stub.

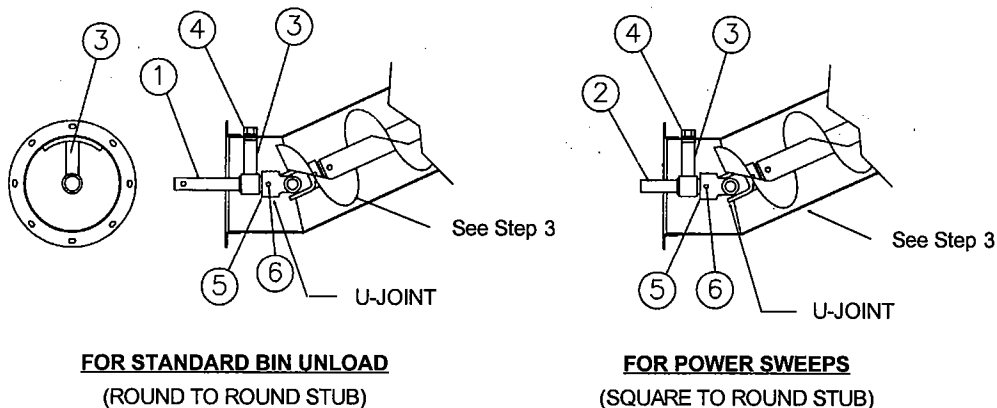

1. Insert the connecting stub (1) or (2) through the hanger bearing (3) and connect it to the u-joint. Secure stub to u-joint with a square key (5) and hex head bolt with locknut (6). On 8" size, key is 1/4" square by 1" long and bolt is 3/8" x 3" long (grade 5). On 10" and 12" sizes, key is 3/8" square by 1" long and bolt is 3/8" x 3 1/2" long (grade 5).
2. Install the hanger bearing assembly (3) inside the auger housing and secure to top of housing with a hex head bolt and lockwasher (4). Use 5/8" x 1" long bolt for 8" and 10" sizes, and use 3/4" x 1" long bolt for 12" size.
3. It is important that the flight be centered in the housing at the end which is connected to the u-joint. If the fighting is close to the top or bottom of the housing, it needs to be adjusted to make it centered. To adjust the flight, loosen the head bearing lock collar so the head stub can be moved in and out through the bearing. Move as required to even out the flight to housing gap and then resecure the bearing lock collar to the head stub shaft.

ASSEMBLY INSTRUCTIONS - CONT.

MOTOR MOUNT ASSEMBLY FOR 6" TO 6", 6" TO 8" AND 8" TO 8" 25° UNLOADING KIT

NOTE: Head plate (3), motor mount rods (4) and head bearing (8) have already been installed on inclined auger tube (1).

1. Loosen top nuts on rods (4) and slide belt guard mounting angle (21) under nuts. Retighten nuts.
2. Attach belt guard back (23) to belt guard mounting angle (21) using two 1/4" x 3/4" carriage bolts with flat washers, lock washers and nuts.
NOTE: Leave carriage bolts loose until motor pulleys and belts are installed.
3. Position motor mount straps (5) and clips (6) on rods (4) and clamp together using two 3/8" x 2 /12" carriage bolts with nuts.
4. Install motor on straps and clips, then install pulley onto motor. Motor pulley is **not** furnished. Install belt or belts (2). Tighten belts by adjusting motor height using four nuts on rods (4). **DO NOT** overtighten driving belt or result will be excessive vibration and flight shaft breakage at the bearing.
5. Adjust belt guard back (23) and tighten bolts. Attach belt guard (22) to mounting angle (21) using clamp bar (18) and two 1/4" x 4 1/2" bolts with nuts.



CAUTION: Keep all safety shields and devices in place.

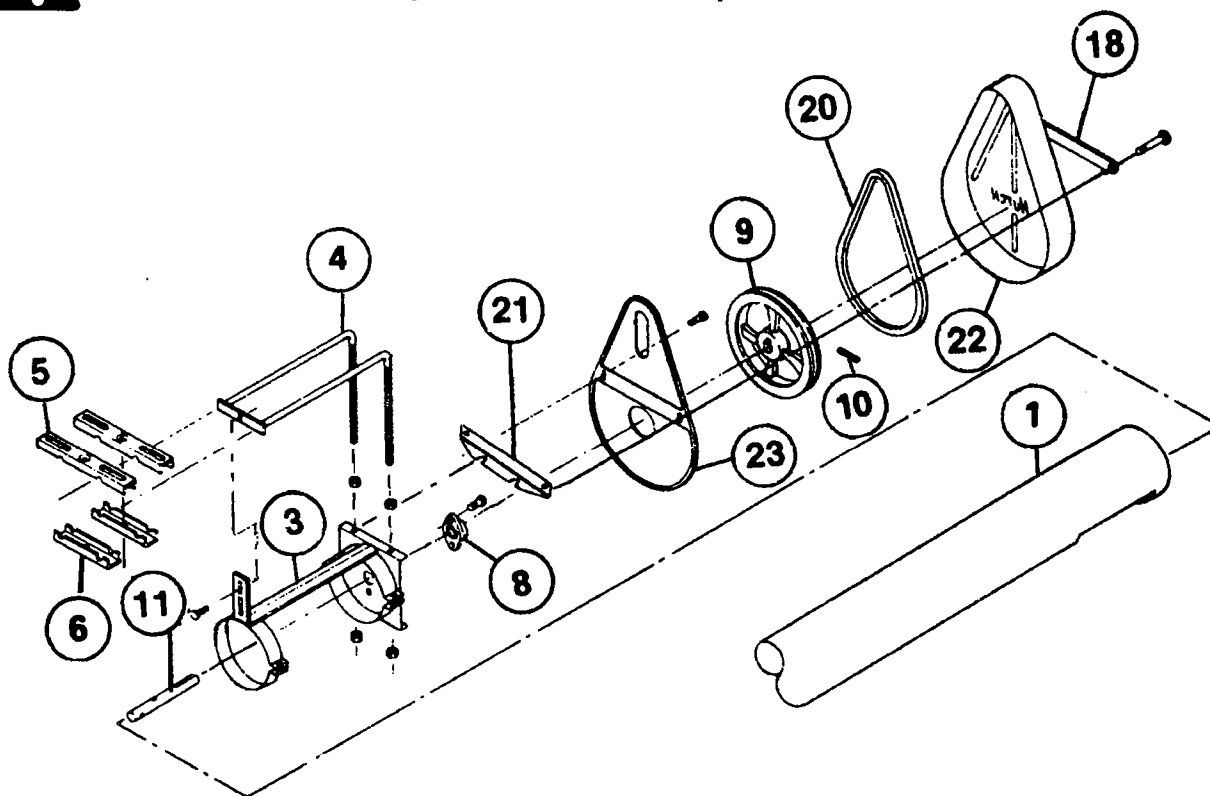

ASSEMBLY INSTRUCTIONS - CONT.

MOTOR MOUNT ASSEMBLY FOR 8" TO 10" - 25° UNLOADING KIT

NOTE: Head plate weldment (1) and head bearing (4) have already been installed on inclined auger tube.

1. Attach motor mount weldment (5) to head plate weldment (1) using two 3/8" x 3/4" long carriage bolts with locknuts.
 2. Bolt the back support plate (8) to the motor mount plate (5) using two 3/8" x 1" long carriage bolts with locknuts.
 3. Clamp motor mount plate (5) to auger tube with band (5A) using two 5/16" x 1 1/2" long bolts with non-lock nuts.
 4. Thread a 3/4" non-lock nut onto each threaded rod of the motor mount rod weldment (2).
 5. Install the motor mount rod weldment (2) down through the 13/16" holes in the top and bottom of the head plate weldment (1) and secure in place by threading 3/4" non-lock nuts on the rods.
 6. Bolt the back bar of the motor mount rod weldment (2) to the back support plate (8) using two 3/8" x 1" long carriage bolts with flatwasher, lockwasher and non-lock nut.
 7. Attach belt guard (9) to head plate weldment (1) using four 3/8" x 1" carriage bolts and nylon locknuts.
 8. Install 15 pulley (10) onto the head stub (12). Install a 3/8" x 3" square drive key (3) to secure pulley to head stub. Secure in place by tightening setscrews in pulley.
 9. Position motor mount straps (top) (6) and motor mount clips (bottom) (7) on rods (2) and clamp together with two 3/8" x 2 1/2" carriage bolts, lockwashers and non-lock nuts.
 10. Install electric motor on motor and pulley on motor. (Not furnished.)
IMPORTANT: Use the proper size and speed motor to ensure satisfactory conveyor operation. Too small of a motor will not supply the horsepower required to achieve capacity and possible damage to the motor will occur. Too large of a motor may cause high stress on conveyor components resulting in shorter life for those components. Align pulleys by using straight edge, placed across the outer face of both pulleys.
 11. Install belt(s) (11) and tighten belt(s) with four adjusting nuts on rod assembly (2).
NOTE: The 3/8" x 1" carriage bolt that attaches the rod assembly (2) to the head plate weldment (1) needs to be loosened in order to make this adjustment).
- DO NOT** over tighten driving belt or result will be excessive vibration and flight shaft breakage at the bearing.
12. Check all fasteners to see if they are tight.

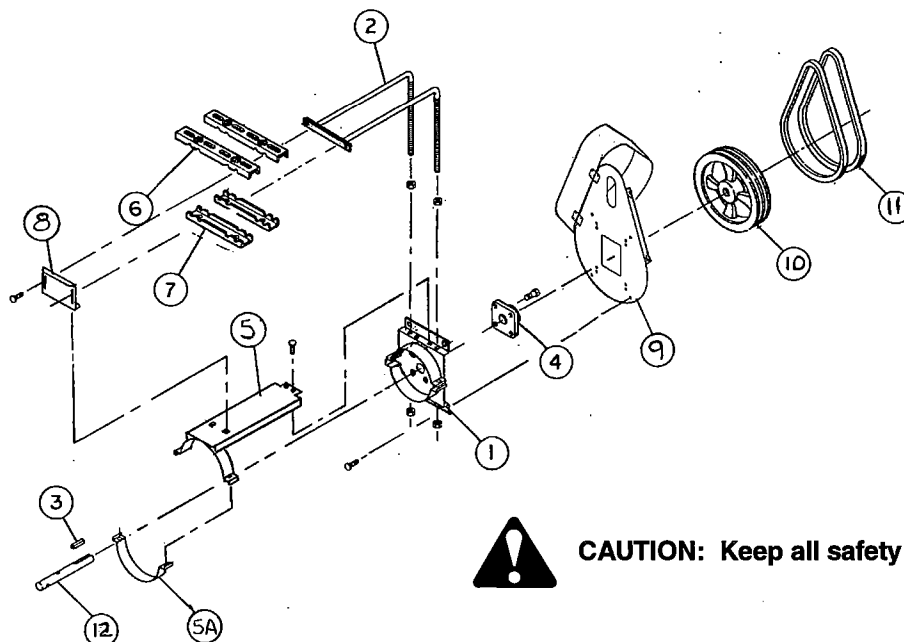

CAUTION: Keep all safety shields and devices in place.

ASSEMBLY INSTRUCTIONS - CONT.

MOTOR MOUNT ASSEMBLY FOR 10" TO 12" - 25° UNLOADING KIT (DIRECT BELT DRIVE)

NOTE: Head plate weldment (1) and head bearing (5) have already been installed on inclined auger tube.

1. Fasten motor mount support (2) and belt guard brackets (4) to the head plate of the housing weldment (1) with four 1/2" x 1 1/4" hex head bolts, lockwashers and non-locknuts.

NOTE: Guard brackets (4) go on outside of motor mount support (2). Also, make certain that the motor mount support (2) is arranged so that the pivot shaft holes are on the right hand side, as seen when looking from the intake end of the auger toward the discharge end. In addition, make sure the back pair of holes in each side of the support (2) are used to mount to the head plate (1).

2. Thread the adjusting rod (7) down through the nut in the top of the motor mount support (2) until it only extends two to three inches above the top of the support (final adjustment will be done after installing motor and belts).
3. Set the motor mount plate (3) down over the motor mount support (2) and align the pivot shaft holes in each. Install the pivot shaft (6) through the holes and install a 3/16" x 1 1/2" cotter pin in each end to secure it in place.
4. Install belt guard (9) and secure to brackets (4) with four 5/16" x 1" long hex head capscrews with flatwashers, lockwashers and nuts. Use the bottom slot of each pair in the guard.
5. Install the 15" diameter sheave (10) onto the head shaft (12) using the 1/4" key (8).
6. Install electric motor mount and pulley on motor. (Not furnished.) See motor mount hole locations on page 14.
IMPORTANT: Use the proper size and speed motor to ensure satisfactory conveyor operation. Too small of a motor will not supply the horsepower required to achieve capacity and possible damage to the motor will occur. Too large of a motor may cause high stress on conveyor components resulting in shorter life for those components. Align by using straight edge, placed across the outer faces of both pulleys.
7. Install belts (11) and tighten belts by adjusting the threaded rod (7) up against the bottom of the motor mount plate (3). Once belts are tensioned properly, install a 3/4" nut onto the threaded rod (7) and secure it tightly against the bottom of the motor mount support (2).
DO NOT over tighten driving belt, as this puts unnecessary load on the chain reducer input shaft bearings.

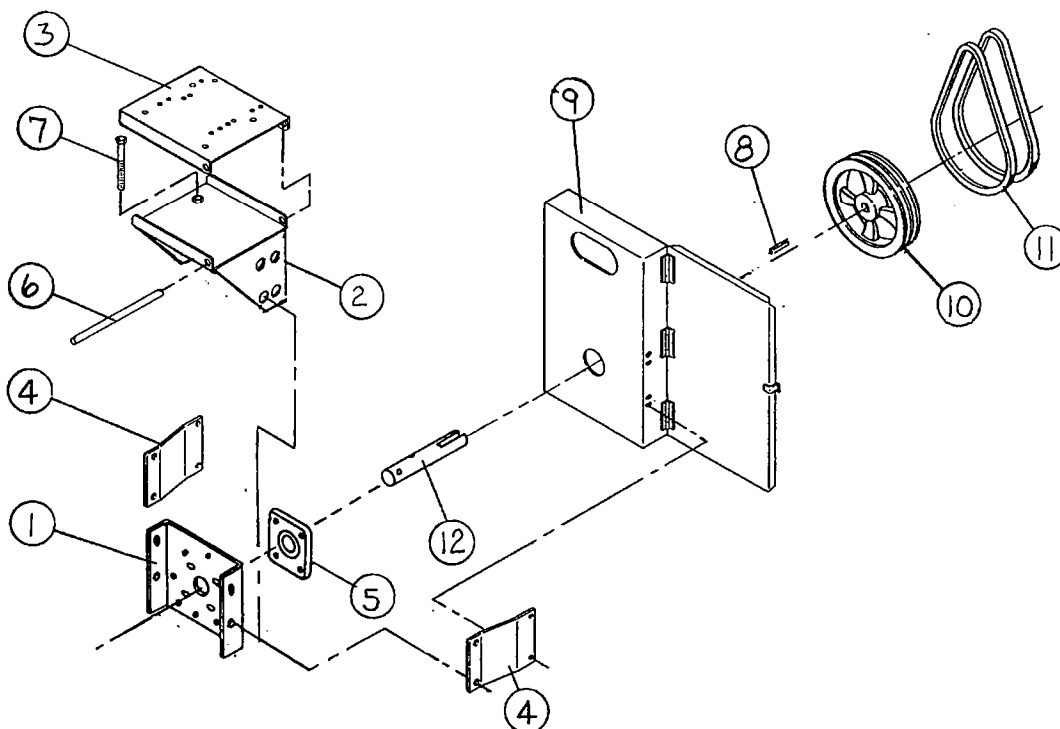

ASSEMBLY INSTRUCTIONS - CONT.

MOTOR MOUNT ASSEMBLY FOR 10" TO 12" - 25° UNLOADING KIT (3 TO 1 REDUCER DRIVE)

NOTE: The chain reducer is shipped **without oil**.
IMPORTANT: Oil must be added during assembly. Remove vented plug and pour in 64 oz. of oil. Replace vented plug. Oil level can be checked by removing check plug. See Fig. 12. Oil should come to the bottom of opening. **DO NOT** add more oil than recommended. Additional oil may damage the seals or be forced out through the vented plug.

OIL - IMPORTANT:

For lubrication in normal operating temperature between 40°F to 120°F, we recommend the use of non-foaming, multi-purpose gear oil, SAE 90 weight. For temperatures below 40°F, use SAE 80 weight oil. Use grade commercially available for automotive differentials. Extra pressure additives may be of value in severe applications.

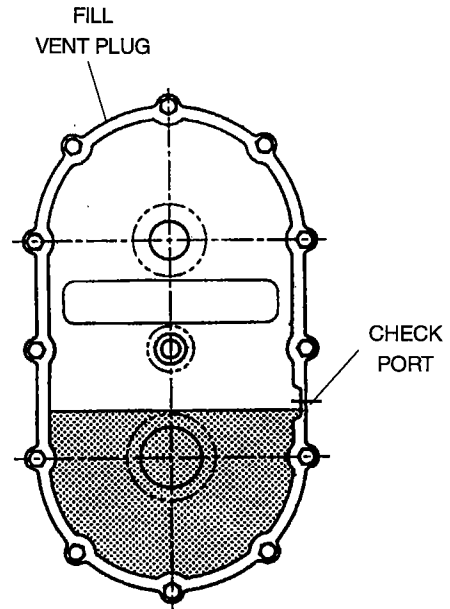

**FIG. 12
CHAIN REDUCER
OIL LEVEL**

1. Mount head plate (1) to angle ring flange at discharge end of auger housing, using eleven 3/8" x 1" long hex head bolts and locknuts.
2. Secure 3:1 chain reducer (8) to ring of head plate (1) using, four 3/8" x 1" long hex head bolts and locknuts.
3. Fasten output shaft of chain reducer (8) to flight using, two 5/8" x 4" long grade 5 bolts and locknuts.
4. Fasten motor mount support (2) and belt guard brackets (6) to the head plate (1) with four 1/2" x 1 1/4" hex head bolts, lockwashers and non-locknuts.

NOTE: Guard brackets (6) go on outside of motor mount support (2). Also, make certain that the motor mount support (2) is arranged so that the pivot shaft holes are on the right hand side, as seen when looking from the intake end of the auger toward the discharge end. In addition, make sure the back pair of holes in each side of the support (2) are used to mount to the head plate (1).

5. Thread the adjusting rod (5) down through the nut in the top of the motor mount support (2) until it only extends two to three inches above the top of the support (final adjustment will be done after installing motor and belts).
6. Set the motor mount plate (3) down over the motor mount support (2) and align the pivot shaft holes in each. Install the pivot shaft (4) through the holes and install a 3/16" x 1 1/2" cotter pin in each end to secure it in place.
7. Install belt guard (9) and secure to brackets (6) with four 5/16" x 1" long hex head bolts with flat washers, lock washers and nuts. Use the bottom slot of each pair in the guard.
8. Install the driven sheave (10) on the reducer input shaft (8) using the QD type hub (11) with key.

ASSEMBLY INSTRUCTIONS - CONT.

MOTOR MOUNT ASSEMBLY FOR 10" TO 12" - 25° UNLOADING KIT (3 to 1 REDUCER DRIVE) - CONT.

9. Install electric motor and mount pulley on motor. (Not furnished.) See motor mount hole locations on page 14.

IMPORTANT: Use the proper size and speed motor to ensure satisfactory conveyor operation. Too small of a motor will not supply the horsepower required to achieve capacity and possible damage to the motor will occur. Too large of a motor may cause high stress on conveyor components resulting in shorter life for those components. Align by using straight edge, placed across the outer faces of both pulleys.

NOTE: With 12" O.D. driven pulley, use 3 1/2" O.D. motor pulley for 170 RPM auger speed.
With 12' O.D. driven pulley, use 5" O.D. motor pulley for 245 RPM auger speed.

10. Install belts (12) and tighten belts by adjusting the threaded rod (5) up against the bottom of the motor mount plate (3). Once belts are tensioned properly, install a 3/4" nut onto the threaded rod (5) and secure it tightly against the bottom of the motor mount support (2).

DO NOT over tighten driving belt, as this puts unnecessary load on the chain reducer input shaft bearings. It will be necessary to check the belt tension as part of the drives periodic maintenance.

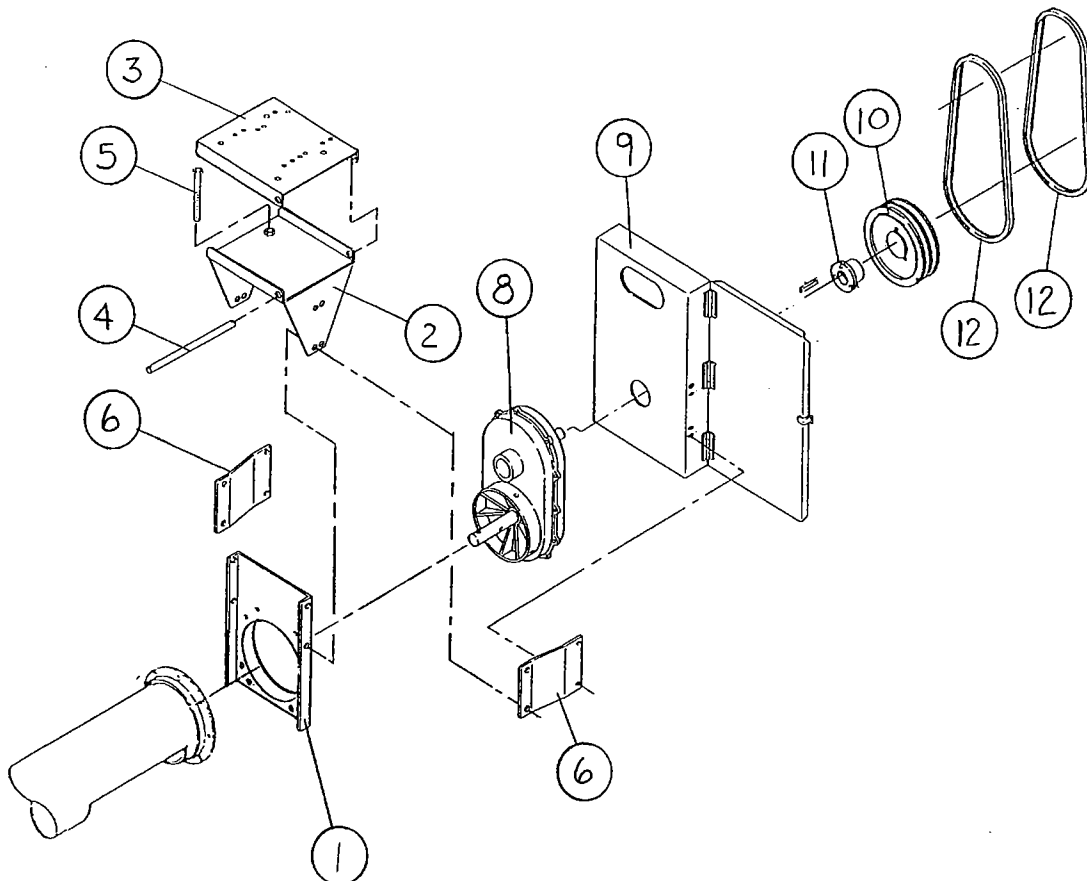

ASSEMBLY INSTRUCTIONS - CONT.

10" TO 12" 25° BIN UNLOADER

MOTOR MOUNT HOLE LOCATION

MOTOR SIZE HP	MOTOR FRAME SIZE	BOLT DIA. REQ'D.	MOUNT IN HOLES MARKED (*)															
			A1	A2	A3	A4	A5	A6	A7	A8	A9	A10	B1	B2	B3	B4		
5	184T	3/8"	*	*	*	*												
7 1/2	213T	3/8"					*	*	*	*								
10	215T	3/8"					*	*			*	*						
15	254T	1/2"											*	*	*	*		

PARTIAL TOP VIEW

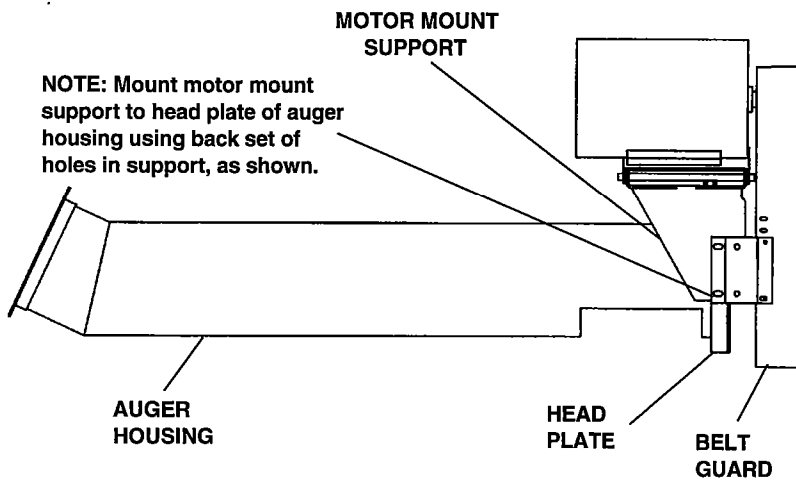
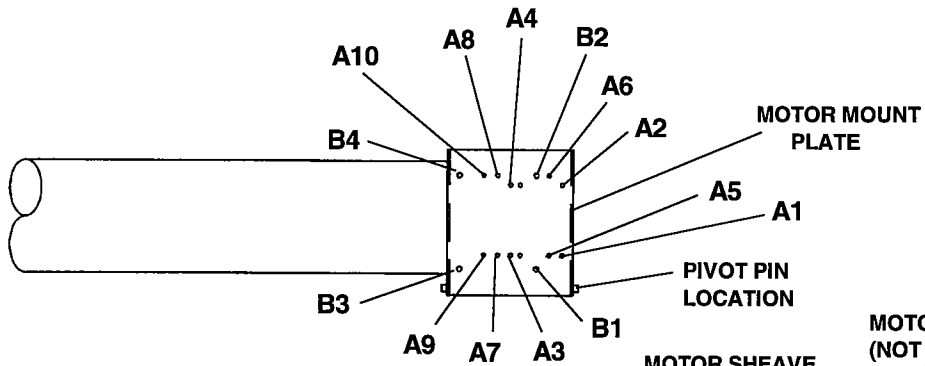

SIDE VIEW

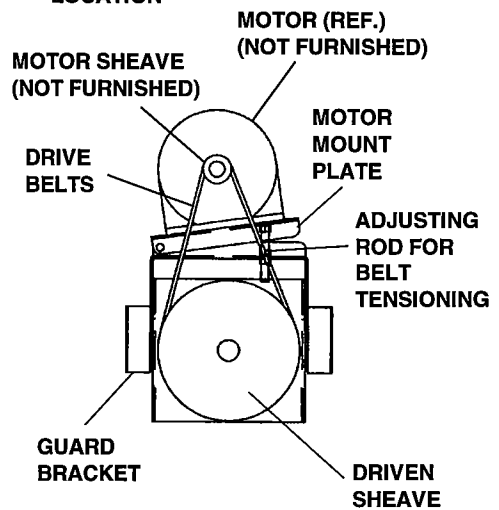

END VIEW

BELT GUARD NOT SHOWN IN THIS VIEW FOR CLARITY

**BELT DRIVE SHOWN
(Reducer Drive Similar)**

SAFETY DECALS

Check components as specified below to insure that safety decals are present and in good condition. If a decal cannot be easily read for any reason or has been painted over, replace it immediately. Decals may be ordered through your dealer.

DANGER Sign No. 1002303 was supplied with the bin unloading auger. This safety sign should be applied to the side of the bin near the opening, so it will be viewed by people entering into the bin or storage building.

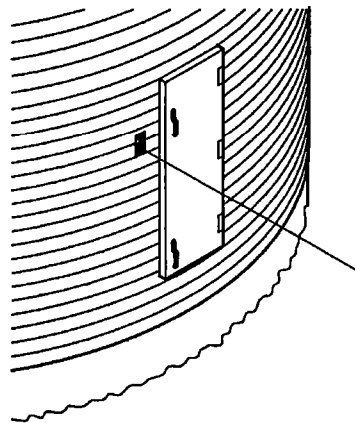

DANGER Sign No. 1002303

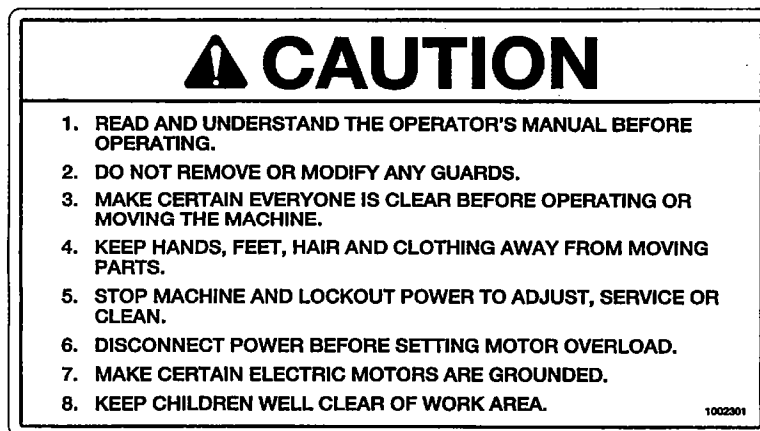

CAUTION Decal
Part No. 1002301

SERIAL NUMBER

To insure efficient and prompt service, please furnish us with the model and serial number of your auger in all correspondence or other contacts. The serial plate is located on the motor mount frame.

PARTS LIST

6" TO 6" - 25° UNLOADING KITS

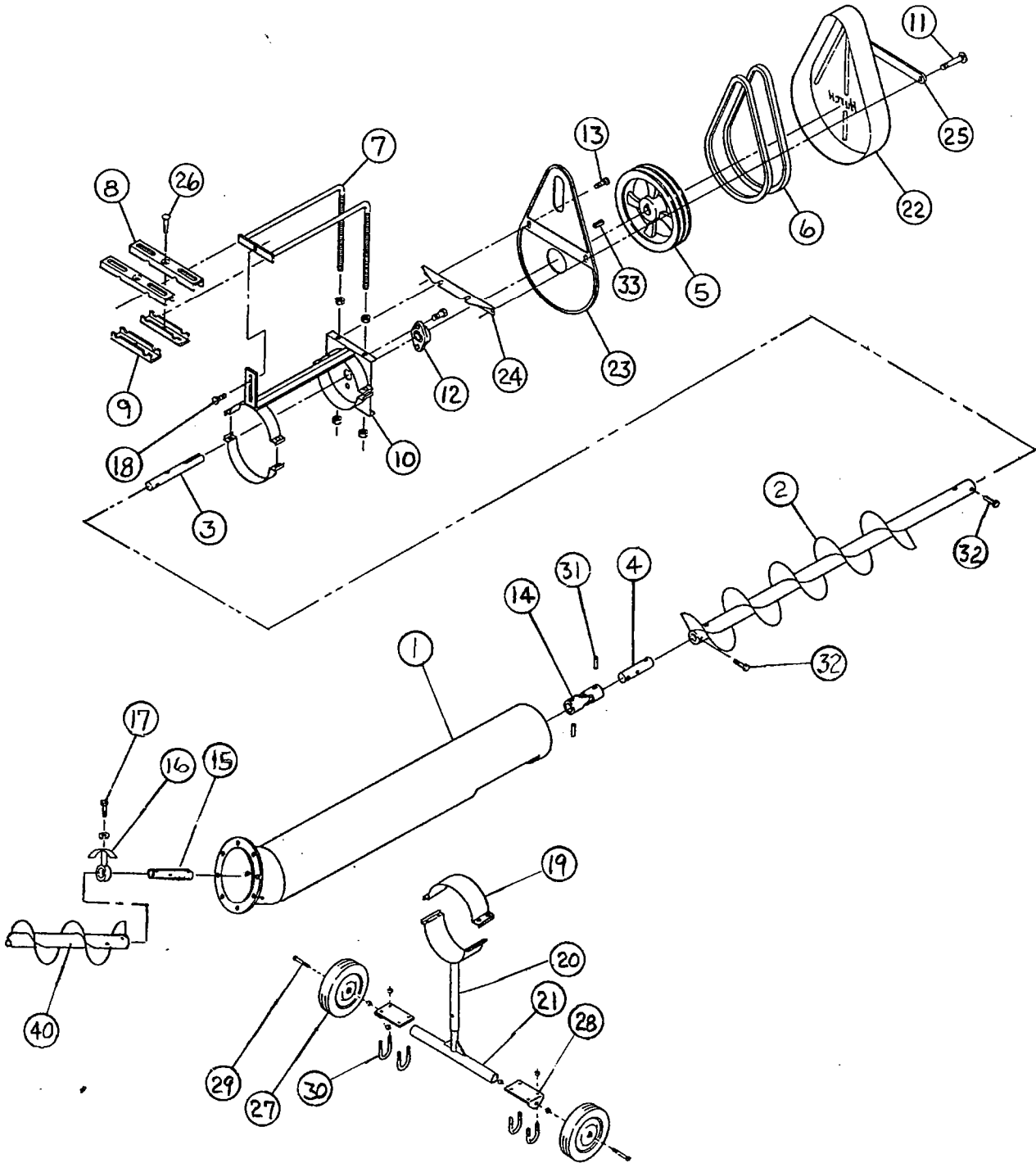

PARTS LIST

6" TO 6" - 25° UNLOADING KITS

REF. NO.	PART NO	DESCRIPTION
1	62900	6" Auger Housing, 5'-10" long with elbow
2	630008	Flighting Assembly, 5'-2 5/16" long
3	6332G	Head Stub for Incline Flighting, 1" x 10" long
4	6359E	Connecting Stub, 1" x 5-5/8" long
5	40151	2B Groove Sheave 12" O.D. with 1" bore
6	40115	B46 Belt
7	6319A	Motor Mount Rod Assembly
8	6853A	Top Motor Mount Strap
9	6854A	Bottom Motor Mount Clip
10	1703C	Head Plate Assembly
11	1002210	Bolt, 1/4" x 4 1/2" Hex Head
12	6818D	1" 2-hole Flange Bearing with Lock Collar
13	1002244	Carriage Bolt, 1/4" x 3/4" long
14	6340A	U-Joint (1" to 1") 5" long
15	1022598	Bearing Connecting Stub (1") 8 1/4" long
16	6314F	Internal Bearing Assembly with Bushing, Bracket, Bolt and Lockwasher
--	6303D	Bronze Bushing (1")
17	1002233	Internal Bearing Bolt, 5/8" x 1"
18	1002238	Carriage Bolt, 5/16" x 3/4"
19	5046A1	6" x 4" wide Half Band (galv.)
20	630005	6" Stand Bracket
21	8808J	Stand Base
22	50925A1	Belt Guard
23	50926A1	Belt Guard Back Plate
24	6308A	Belt Guard Mounting Angle
25	6324C	Belt Guard Clamp Bar x 14" long (galv.)
26	1002242	Carriage Bolt, 3/8" x 2 1/2" long
27	5338A	10" Wheel Assembly (for optional wheel kit)
28	51179	Wheel Mounting Bracket
29	1002204	5/8" x 4" Bolt
30	3060A1	U-Bolt (3/8" x 2" between legs)
31	33243	Roll Pin, 5/16" x 1 3/4" (spiral)
32	D1174	Bolt, 3/8" x 2 1/4" Grade 5
33	4045A1	Square Key, 1/4" x 2" long
40	---	Bin Unloading Flight (See Page P-12).

PARTS LIST

6" TO 8" - 25° UNLOADING KITS

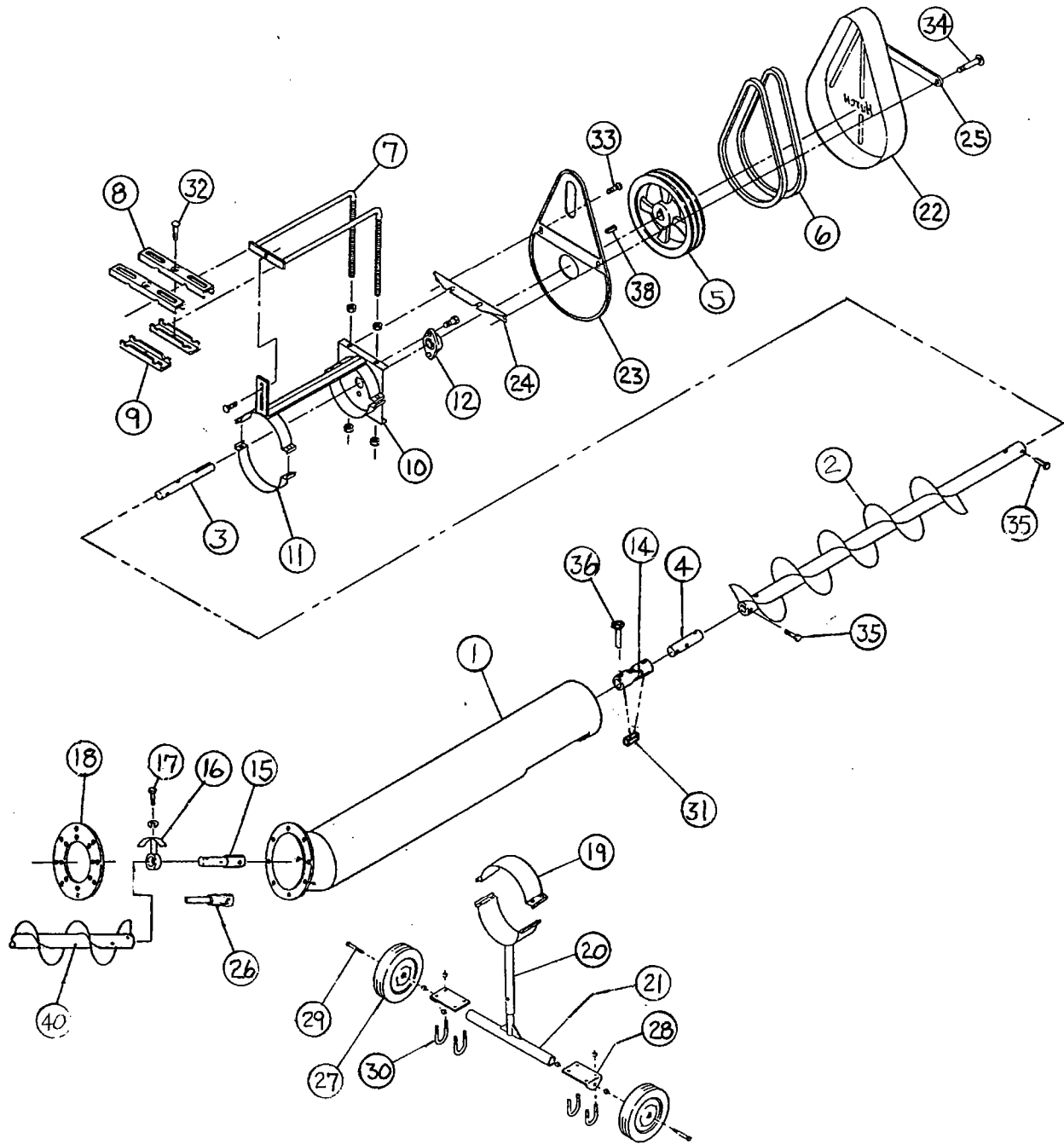

PARTS LIST

6" TO 8" - 25° UNLOADING KITS

REF. NO.	PART NO	DESCRIPTION
1	62887	8" Auger Housing, 5'-9" long with elbow
2	1022614	Flighting Assembly, 5'-4 1/2" long
3	8326A	Head Stub for Incline Flighting, 1 1/4" x 10" long
4	1015304	Connecting Stub, 1 1/4" x 5-3/4" long
5	40152	12" O.D. 2-Groove Sheave (1 1/4" bore)
6	40116	B48 Belt
7	8318A	Motor Mount Rod Assembly (3/4")
8	6853A	Top Motor Mount Strap
9	6854A	Bottom Motor Mount Clip
10	8324A	Head Plate Assembly
11	5033A1	2" wide Half Band (galv.)
12	8325A	1 1/4" 2-hole Flange Bearing with Lock Collar
14	1015313	U-Joint (1 1/4" to 1 1/4") 5" long
15	1022600	Bearing Connecting Stub (1 1/4") 8 1/4" long
16	8392C	Internal Bearing Assembly (with Bushing, Bolt and Lockwasher)
--	8379C	Bronze Bushing (1 1/4")
17	1002233	Internal Bearing Bolt, 5/8" x 1"
18	1016807	6" to 8" Adapter Plate
19	5042A1	8" x 4" wide Half Band (galv.)
20	6283A1	8" Stand Bracket
21	8808J	Stand Base
22	50925A1	Belt Guard
23	50926A1	Belt Guard Back Plate
24	6308A	Belt Guard Mounting Angle 14" long
25	6324C	Belt Guard Clamp Bar x 14" long (galv.)
26	1015309	Square to Round Bearing Stub, 5-7/8" long (for power sweep)
27	5338A	10" Wheel Assembly (for optional wheel kit)
28	51179	Wheel Mounting Bracket
29	1002204	5/8" x 4" Bolt
30	3060A1	U-Bolt (3/8" x 2" between legs)
31	4020A1	Key, 1/4" Square x 1"
32	1002242	Carriage Bolt, 3/8" x 2 1/2" long
33	1002244	Carriage Bolt, 1/4" x 3/4" long
34	1002210	Bolt, 1/4" x 4 1/2" Hex Head
35	1002253	Bolt, 7/16" x 2 1/2" Hex Head, Grade 5
36	33068	Bolt, 3/8" x 3" Hex Head, Grade 5
37	1002238	Carriage Bolt, 5/16" x 3/4" long
38	4045A1	Square Key, 1/4" x 2" long
40	---	Bin Unloading Flight (See Page P-12).

PARTS LIST

8" TO 8" - 25° UNLOADING KITS

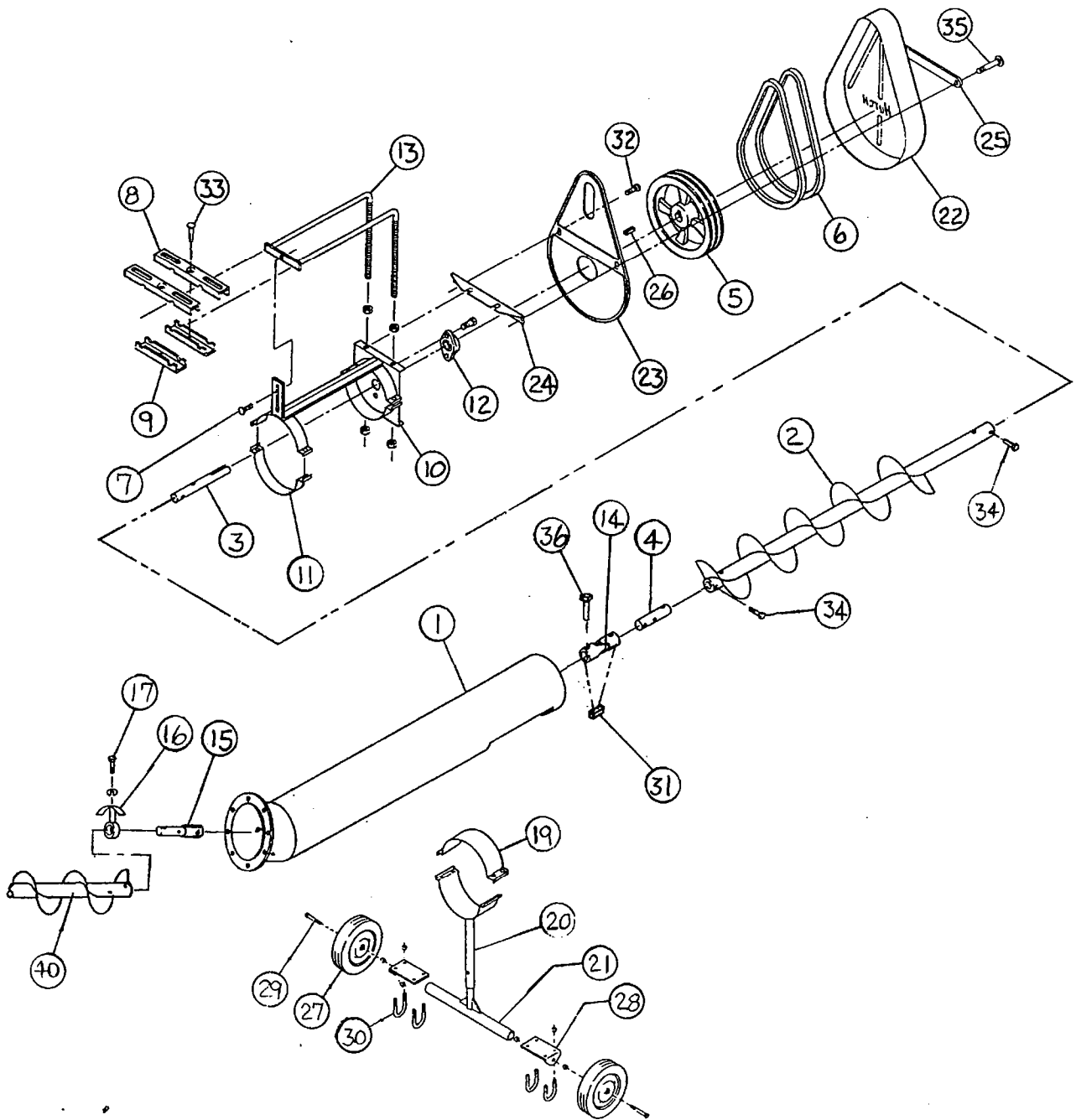

PARTS LIST

8" TO 8" - 25° UNLOADING KITS

REF. NO.	PART NO	DESCRIPTION
1	62887	8" Auger Housing, 5'-9" long with elbow
2	1022614	Flighting Assembly, 5'-4 1/2" long
3	8326A	Head Stub for Incline Flighting, 1 1/4" x 10" long
4	1015304	Connecting Stub, 1 1/4" x 5-3/4" long
5	40152	12" O.D. 2-Groove Sheave (1 1/4" bore)
6	40116	B48 Belt
7	1001631	Carriage Bolt, 3/8" x 1" long
8	6853A	Top Motor Mount Strap (12" long)
9	6854A	Bottom Motor Mount Clip
10	8324A	Head Plate Weldment
11	5033A1	2" wide Half Band (galv.)
12	8325A	1 1/4" 2-hole Flange Bearing with Lock Collar
13	8318A	Motor Mount Rod Weldment (3/4")
14	1015313	U-Joint (1 1/4" to 1 1/4") 5" long
15	1022601	Bearing Connecting Stub (1 1/4") 8 3/8" long
16	8392C	Internal Bearing Assembly (with Bushing, Bracket, Bolt and Lockwasher)
--	8379C	Bronze Bushing (1 1/4")
17	1002233	Internal Bearing Bolt, 5/8" x 1"
19	5042A1	8" x 4" wide Half Band (galv.)
20	6283A1	8" Stand Bracket
21	8808J	Stand Base
22	50925A1	Belt Guard
23	50926A1	Belt Guard Back Plate
24	6308A	Belt Guard Mounting Angle 14" long
25	6324C	Belt Guard Clamp Bar x 14" long (galv.)
26	4045A1	Square Key, 1/4" x 2" long
27	5338A	10" Wheel Assembly (for optional wheel kit)
28	51179	Wheel Mounting Bracket
29	1002204	5/8" x 4" Bolt
30	3060A1	U-Bolt (3/8" x 2" between legs)
31	4020A1	Key, 1/4" Square x 1"
32	1002244	Carriage Bolt, 1/4" x 3/4" long
33	1002242	Carriage Bolt, 3/8" x 2 1/2" long
34	1002253	Bolt, 7/16" x 2 1/2" Hex Head, Grade 5
35	1002210	Bolt, 1/4" x 4 1/2" Hex Head
36	33068	Bolt, 3/8" x 3" Hex Head, Grade 5
40	---	Bin Unloading Flight (See Page P-12).

PARTS LIST

- 8" TO 10" UNLOADING KITS
AND 8" COMMERCIAL

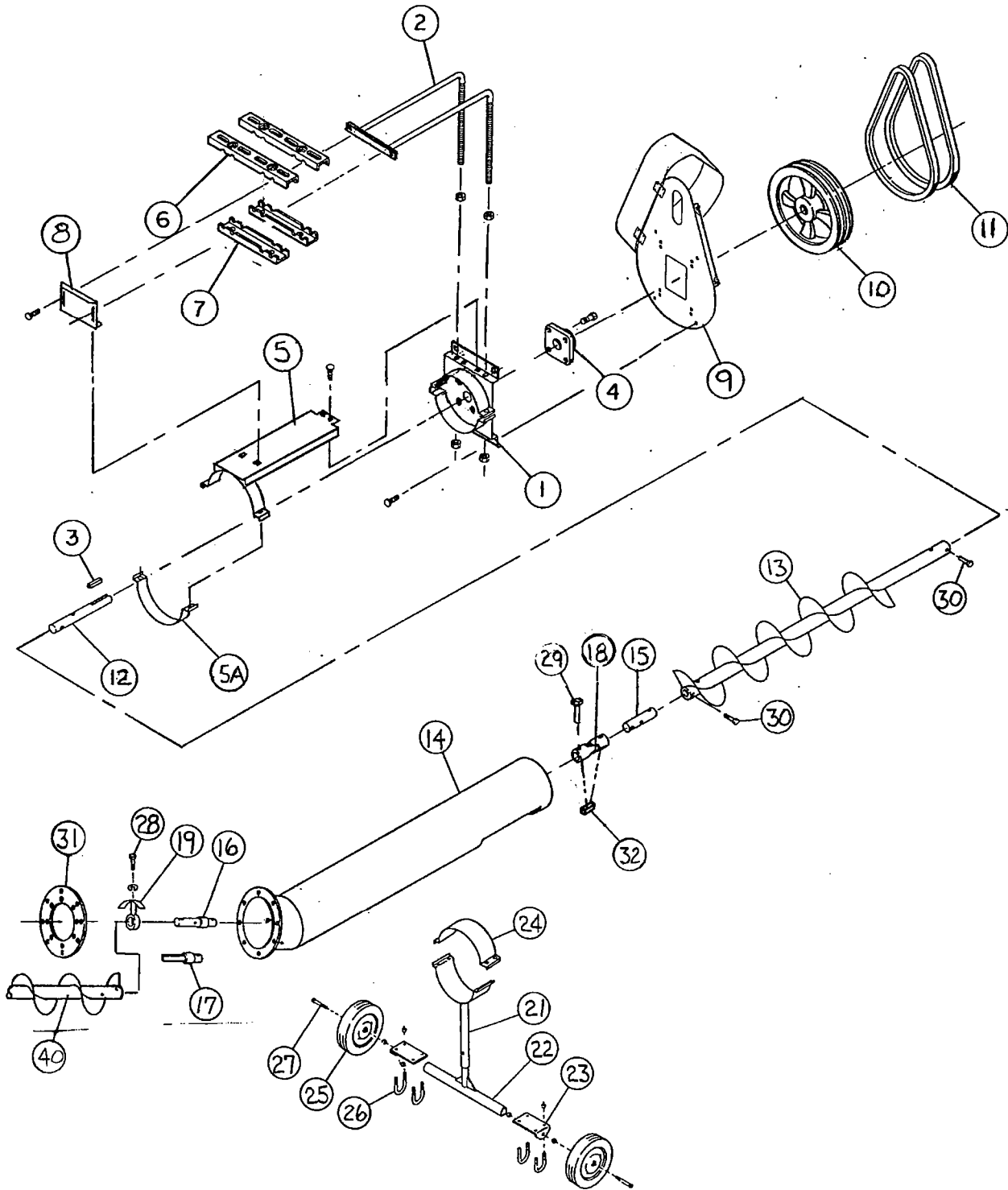

PARTS LIST

8" TO 10" UNLOADING KITS

REF. NO.	PART NO	DESCRIPTION
1	1013379	Head Plate Weldment
2	1013381	Motor Mount Rod Weldment
3	4073A1	Key, 3/8" x 3" long
4	1010A	Bearing, Head, 1 1/2" 4-Hole
5	1013380	Motor Mount Weldment
5A	5035A1	Half Band, 10" x 2" wide
6	50435A1	Top Motor Mount Strap
7	50434A1	Bottom Motor Mount Clip
8	1013169	Back Support Plate
9	1013429	Belt Guard
10	40159	Sheave 2-Groove x 15" w/1 1/2" Bore
10	40162	Sheave 3-Groove x 15" w/1 1/2" Bore
11	1023004	Belt, B-59
12	1060D	Head Stub, 1 1/2" x 11 1/2"
13	1022613	Flight Weldment
14	1022617	Auger Housing Weldment
15	1015306	Connecting Stub
16	1022602	Bearing Connecting Stub, (1 1/4" to 1 1/2") 8 5/8" long
17	1015308	Bearing Connecting Stub (Square to Round) (for power sweep)
18	1015292	U-Joint, 1 1/2"
19	1055D	Internal Bearing Bracket w/Bushing & Bolt
--	1051D	Bronze Bushing (1 1/2")
21	6284A	10" Stand Bracket
22	8808J	Stand Base
23	51179	Wheel Mounting Bracket
24	5044A1	10" x 4" wide Half Band
25	5338A	10" Wheel Assembly (f/optional wheel kit)
26	3060A1	U-Bolt, 3/8" x 2"
27	1002204	5/8" x 4" Bolt
28	33276	Internal Bearing Bolt, 5/8" x 1 1/2"
29	4827	Bolt, 3/8" x 3 1/2" Hex Head, Grade 5
30	33091	Bolt, 1/2" x 3" Hex Head, Grade 5
31	1022687	Adapter Plate 8" to 10"
32	1002276	Key, 3/8" Square x 1" lg.
40	---	Bin Unloading Flight (See Pages P-12 & P-13).

PARTS LIST

10" TO 12" UNLOADING KITS
AND 10" COMMERCIAL

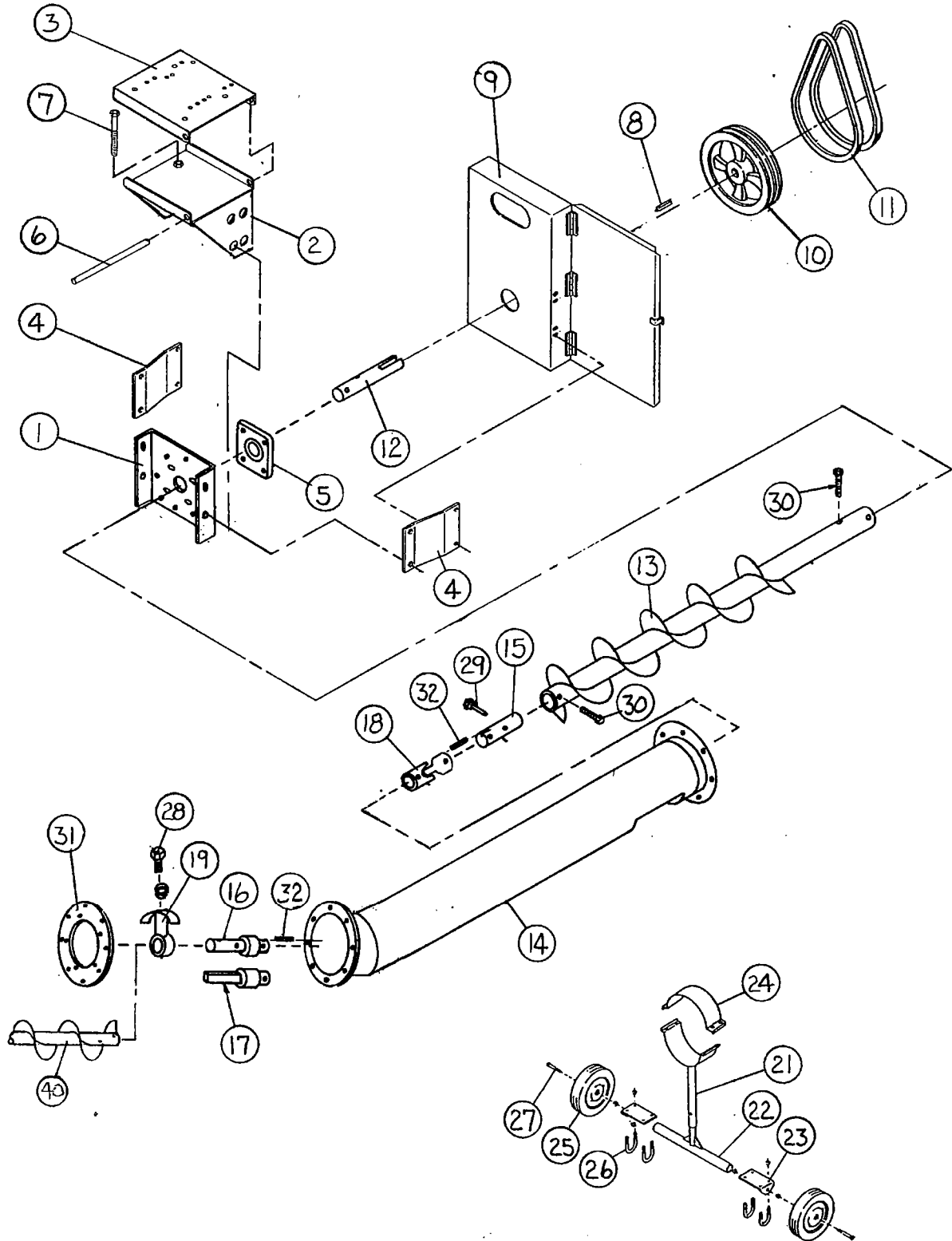

PARTS LIST

10" TO 12" UNLOADING KITS

(Ref. No's. 1-12 for Direct Belt Drive, See page P-12 for 3:1 Reducer Drive)

REF. NO.	PART NO	DESCRIPTION
1	2229C	Head Plate
2	1022140	Motor Mount Support Weldment
3	1022136	Motor Mount Plate
4	1022156	Belt Guard Bracket
5	2214C	Bearing, Head 2" 4-Hole
6	1018789	Pivot Pin
7	1022381	Adjusting Rod
8	1038D	Key, 3/8" x 2" (2-belt drive)
8	4073A1	Key, 3/8" x 3" (3-belt drive)
9	1009102	Belt Guard
10	40159	Sheave 2-Groove x 15" w/1 1/2" Bore
10	40162	Sheave 3-Groove x 15" w/1 1/2" Bore
11	40124	Belt, B-66
12	2220C	Head Stub, 2" x 12" long
13	1022623	Flight Weldment
14	1022618	Auger Housing Weldment
15	1015305	Connecting Stub, (1 1/2" to 2") 6 1/8" long
16	1022603	Bearing Connecting Stub, (1 1/2" to 2" to 1 1/2") 8 3/8" long
17	1022612	Bearing Connecting Stub (Square to Round) (for power sweep)
18	1015292	U-Joint, 1 1/2"
19	1264D	Internal Bearing Bracket w/Bushing & Bolt
--	1254D	Bronze Bushing (2")
21	6285A1	12" Stand Bracket
22	8808J	Stand Base
23	51179	Wheel Mounting Bracket
24	5270A1	12" x 4" wide Half Band
25	5338A	10" Wheel Assembly (f/optional wheel kit)
26	3060A1	U-Bolt, 3/8" x 2"
27	1002204	5/8" x 4" Bolt
28	1002237	Internal Bearing Bolt, 3/4" x 1"
29	4827	Bolt, 3/8" x 3 1/2" Hex Head, Grade 5
30	33103	Bolt, 5/8" x 3 1/2" Hex Head, Grade 5
31	2203J	Adapter Plate 10" to 12"
32	1002276	Key, 3/8" x 1" lg.
40	---	Bin Unloading Flight (See Pages P-14 & P-15).

PARTS LIST

3:1 REDUCER DRIVE

REF. NO.	PART NO.	DESCRIPTION
1	1022995	Head Plate
2	1022987	Motor Mount Support
3	1022136	Motor Mount Plate
4	1018789	Pivot Pin
5	1022381	Adjusting Rod
6	1026507	Belt Guard Bracket
8	1011904	Enclosed Chain Drive, 3:1 Reduction
9	1009101	Belt Guard
10	40152	Sheave, 12" O.D. (2-Belt)
10	40154	Sheave, 12" O.D. (3-Belt)
12	40119	Belt, B-54 (for 12" Sheave w/3.5" Motor Sheave)
12	40120	Belt, B-57 (for 12" Sheave w/5" Motor Sheave)

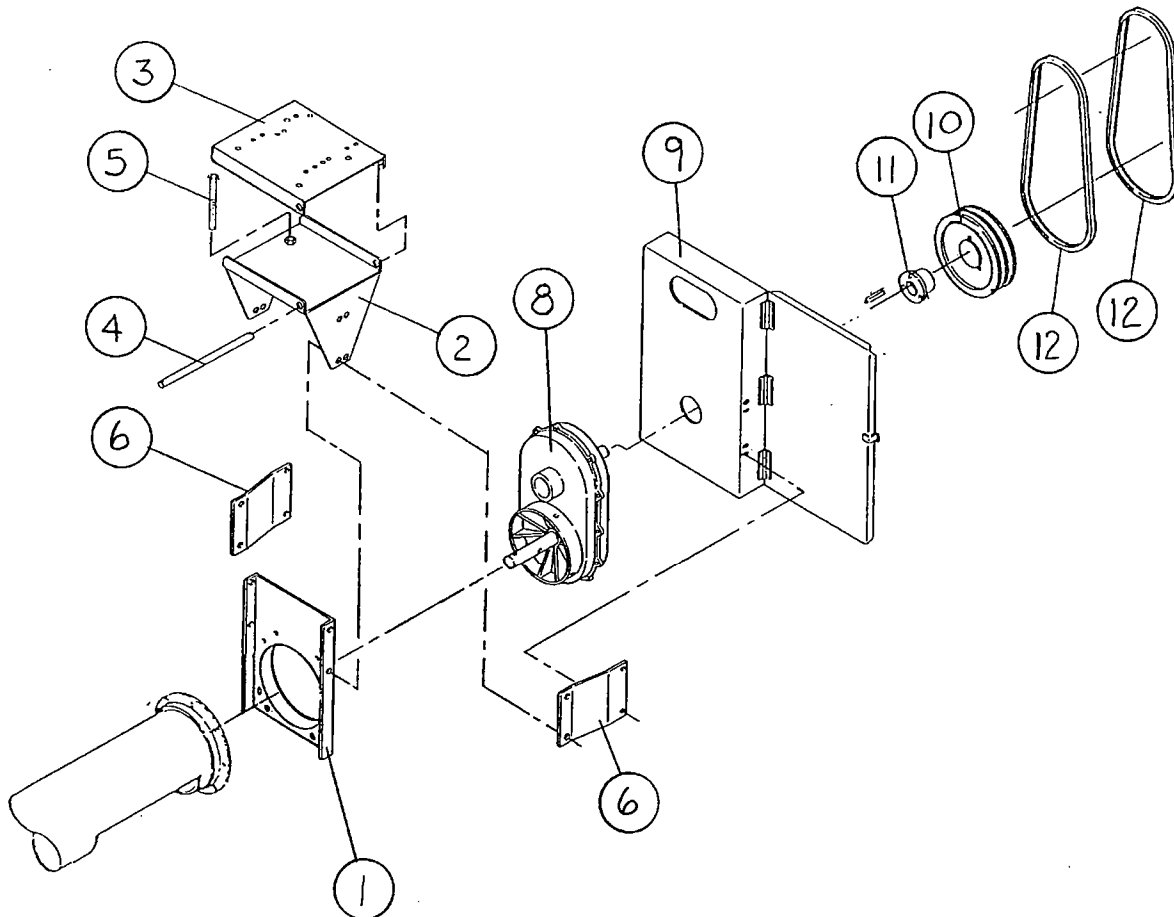

PARTS LIST

ENCLOSED DRIVE - RATIO 3 TO 1

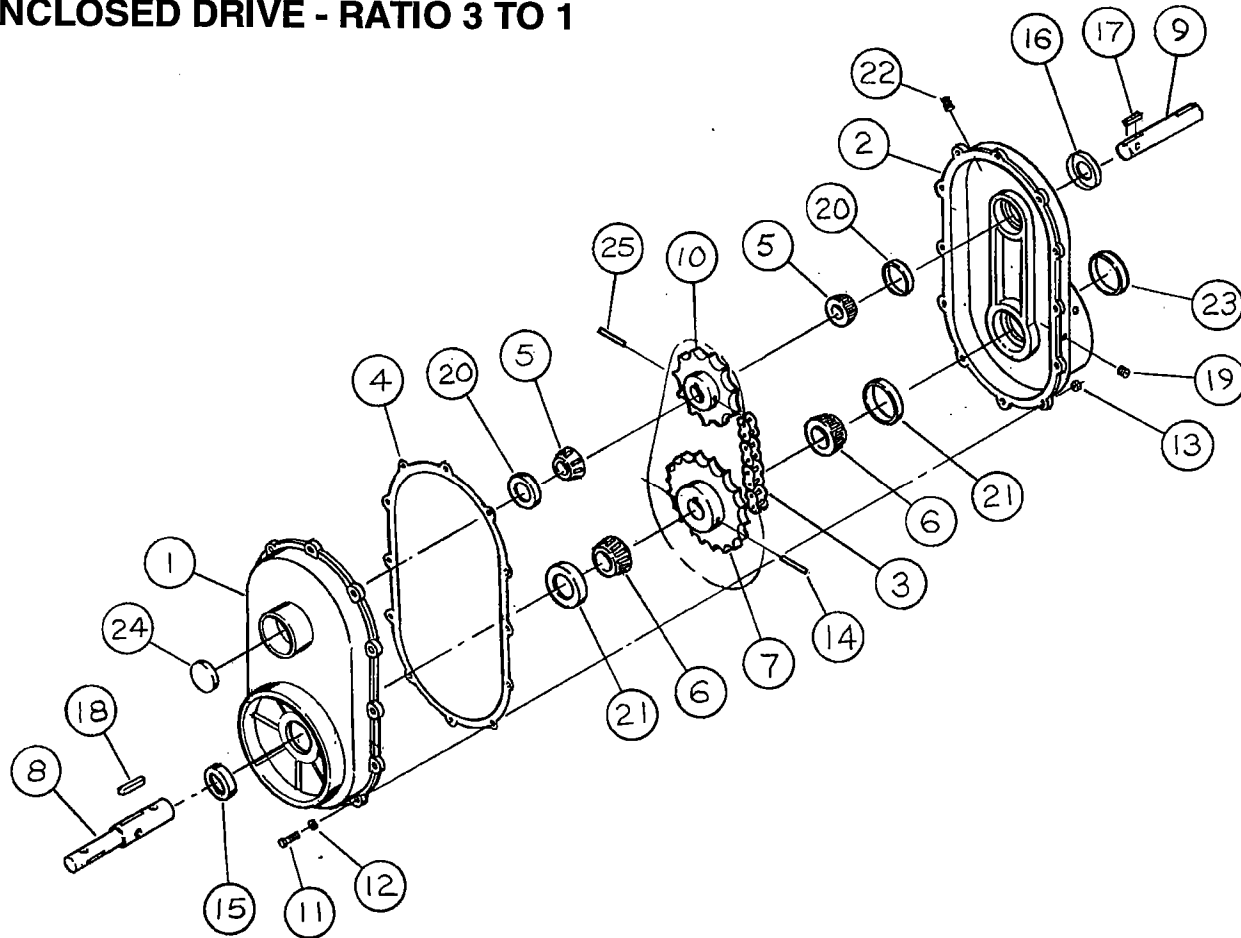

COMPLETE ASSEMBLY NO. 1011904

REF. NO.	PART NO.	DESCRIPTION	REF. NO.	PART NO.	DESCRIPTION
1	1001523	Aluminum Casting (inside)	14	33190	5/16" x 2 1/2" Roll Pin
2	1003044	Aluminum Casting (outside)	15	035860	Output Shaft Seal - 1 1/2"
3	1001847	#80 Roller Chain - 36 Pitch (includes connecting link)	16	835168	Input Shaft Seal - 1 1/4"
4	1001573	Gasket	17	4020A1	Square Key 1/4" x 1"
5	106322	1 1/4" Bearing Cone (Timken No. 15123)	18	1002276	Square Key 3/8" x 1"
6	035439	1 1/2" Bearing Cone (Timken No. LM29749)	19	458026	Drain Plug - 3/8"
7	1001841	1 1/2" Bore Sprocket - 27 tooth	20	106323	1 1/4" Bearing Cup (Timken No. 15245)
8	1011905	Stub Output Shaft - 2"	21	035440	1 1/2" Bearing Cup (Timken No. LM29710)
9	1001850	Stub Input Shaft - 1 1/4"	22	1001438	3/8" Pipe (vented plug)
10	1001840	1 1/4" Bore Sprocket - 9 tooth	23	1001851	Cap
11	4727-1	5/16" x 1 1/4" HHCS	24	1001852	Cap
12	33144	5/16" Lockwasher	25	33193	5/16" x 2" Roll Pin
13	33151	5/16" Lock Nut	26*	1002275	Decal, "Fill with oil"

*Not shown

PARTS LIST

BIN UNLOADING FLIGHTS

FOR 6" TO 6" AND 6" TO 8" STANDARD 25° UNLOADERS Without Power Sweep (See Pages P-2 & P-4)

REF. NO.	PART NO	DESCRIPTION
40	1022323	Bin Unload Flight f/14'-16' Bin (8'-9" lg.)
40	1022324	Bin Unload Flight f/17'-19' Bin (10'-9" lg.)
40	1022325	Bin Unload Flight f/20'-22' Bin (11'-9" lg.)
40	1022326	Bin Unload Flight f/23'-25' Bin (13'-3" lg.)
40	1022327	Bin Unload Flight f/26'-28' Bin (14'-9" lg.)
40	1022328	Bin Unload Flight f/29'-31' Bin (16'-4" lg.)
40	1022329	Bin Unload Flight f/32'-24' Bin (18'-3" lg.)
40	1022330	Bin Unload Flight f/35'-37' Bin (19'-3" lg.)

FOR 6" TO 8" STANDARD 25° UNLOADERS With Power Sweep (See Page P-4)

REF. NO.	PART NO	DESCRIPTION
40	6801P	Bin Unload Flight f/14'-16' Bin (10'-3/4" lg.)
40	6802P	Bin Unload Flight f/17'-19' Bin (12'-3/4" lg.)
40	6803P	Bin Unload Flight f/20'-22' Bin (13'-3/4" lg.)
40	6804P	Bin Unload Flight f/23'-25' Bin (14'-6 3/4" lg.)
40	6805P	Bin Unload Flight f/26'-28' Bin (16'-3/4" lg.)
40	6806P	Bin Unload Flight f/29'-31' Bin (17'-6 3/4" lg.)
40	62727	Bin Unload Flight f/32'-24' Bin (19'-6 3/4" lg.)
40	6808P	Bin Unload Flight f/35'-37' Bin (20'-6 3/4" lg.)

FOR 8" TO 8" AND 8" TO 10" STANDARD 25° UNLOADERS Without Power Sweep (See Pages P-6 & P-8)

REF. NO.	PART NO	DESCRIPTION
40	8831D	Bin Unload Flight f/14'-16' Bin (8'-10" lg.)
40	8832D	Bin Unload Flight f/17'-19' Bin (10'-10" lg.)
40	8833D	Bin Unload Flight f/20'-22' Bin (11'-10" lg.)
40	8834D	Bin Unload Flight f/23'-25' Bin (13'-4" lg.)
40	8835D	Bin Unload Flight f/26'-28' Bin (14'-10" lg.)
40	8836D	Bin Unload Flight f/29'-31' Bin (16'-4" lg.)
40	12153	Bin Unload Flight f/32'-24' Bin (18'-4" lg.)
40	8838D	Bin Unload Flight f/35'-37' Bin (19'-4" lg.)
40	1022402	Bin Unload Flight f/41'-43' Bin (22'-10" lg.)
40	1022403	Bin Unload Flight f/47'-49' Bin (25'-10" lg.)

FOR 8" TO 10" STANDARD 25° UNLOADERS With Power Sweep (See Page P-8)

REF. NO.	PART NO	DESCRIPTION
40	8801P	Bin Unload Flight f/14'-16' Bin (10'-3/4" lg.)
40	8802P	Bin Unload Flight f/17'-19' Bin (12'-3/4" lg.)
40	8803P	Bin Unload Flight f/20'-22' Bin (13'-3/4" lg.)
40	8804P	Bin Unload Flight f/23'-25' Bin (14'-6 3/4" lg.)
40	8805P	Bin Unload Flight f/26'-28' Bin (16'-3/4" lg.)
40	8806D	Bin Unload Flight f/29'-31' Bin (17'-6 3/4" lg.)
40	62728	Bin Unload Flight f/32'-24' Bin (19'-6 3/4" lg.)
40	8808P	Bin Unload Flight f/35'-37' Bin (20'-6 3/4" lg.)
40	8809P	Bin Unload Flight f/38'-40' Bin (22'-3/4" lg.)
40	8810P	Bin Unload Flight f/41'-43' Bin (24'-3/4" lg.)
40	8811P	Bin Unload Flight f/47'-49' Bin (27'-3/4" lg.)

PARTS LIST

BIN UNLOADING FLIGHTS

FOR 10" TO 12" STANDARD 25° UNLOADERS
Without Power Sweep (See Page P-10).

REF. NO.	PART NO.	DESCRIPTION
40	2833D	Bin Unload Flight f/23'-25' Bin (13'-6" lg.)
40	2835D	Bin Unload Flight f/26'-28' Bin (15'-0" lg.)
40	2836D	Bin Unload Flight f/29'-31' Bin (16'-6" lg.)
40	12155	Bin Unload Flight f/32'-34' Bin (18'-6" lg.)
40	2838D	Bin Unload Flight f/35'-37' Bin (19'-6" lg.)
40	1022400	Bin Unload Flight f/41'-43' Bin (23'-0" lg.)
40	1022401	Bin Unload Flight f/47'-49' Bin (26'-0" lg.)

FOR 10" TO 12" STANDARD 25° UNLOADERS
With Power Sweep (See Page P-10).

REF. NO.	PART NO.	DESCRIPTION
40	6426A1A	Bin Unload Flight f/23'-25' Bin (14'-6 3/4" lg.)
40	6426A1B	Bin Unload Flight f/26'-28' Bin (16'-3/4" lg.)
40	6426A1C	Bin Unload Flight f/29'-31' Bin (17'-6 3/4" lg.)
40	62729	Bin Unload Flight f/32'-34' Bin (19'-6 3/4" lg.)
40	6426A1E	Bin Unload Flight f/35'-37' Bin (20'-6 3/4" lg.)
40	6426A1F	Bin Unload Flight f/38'-40' Bin (22'-3/4" lg.)
40	6426A1G	Bin Unload Flight f/41'-43' Bin (24'-3/4" lg.)
40	6426A1H	Bin Unload Flight f/47'-49' Bin (27'-3/4" lg.)

8" COMMERCIAL 25° BIN UNLOADING FLIGHTS (ITEM NO. 40, PAGE P-8)

10" COMMERCIAL 25° BIN UNLOADING FLIGHT (ITEM NO. 40, PAGE P-10)

BIN DIA.	FLIGHT SECTION NO. 1		FLIGHT SECTION NO. 2		DIA.	FLIGHT SECTION NO. 1		FLIGHT SECTION NO. 2	
	LENGTH	PART NO.	LENGTH	PART NO.		LENGTH	PART NO.	LENGTH	PART NO.
24'	14'-6"	11842			24'	14'-16"	11845		
27'	16'-0"	11843			27'	16'-0"	11846		
30'	17'-6"	11790			30'	17'-6"	11709		
33' & 34'	19'-6"	11844			33'-34'	19'-6"	11902		
36'	20'-6"	11792			36'	20'-6"	11800		
37' & 39'	22'-0"	11784			37'-39'	22'-0"	11793		
40'	23'-0"	11785			40'	23'-0"	11794		
42'	24'-0"	11786			42'	24'-0"	11795		
48'	20'-0"	12006	7'-0"	11787	48'-49'	20'-0"	11910	7'-0"	11796
54'-55'	20'-0"	12006	10'-10"	11788	54'-55'	20'-0"	11910	10'-10"	11909
60'	20'-0"	12006	13'-0"	11789	60'	20'-0"	11910	13'-0"	11797
63'	20'-0"	12006	14'-0"	11802	63'	20'-0"	11910	14'-0"	11798
68'-69'	20'-0"	12006	17'-6"	12004	68'-69'	20'-0"	11910	17'-6"	12007
72'	20'-0"	12006	19'-0"	11791	72'	20'-0"	11910	19'-0"	11903
75'	20'-0"	12006	20'-6"	12005	75'	20'-0"	11910	20'-6"	12008
78'	20'-0"	12006	22'-6"	11883	78'	20'-0"	11910	22'-6"	11904

NOTES ON COMMERCIAL FLIGHTS:

- No. 1 flight sections do not include stubs. No. 2 flight sections do include stubs.
- Flight sections No. 1 connect to the bearing stub (Item 16 on Pages P-8 or P-10.)



Hutchinson/Mayrath

A Division of **GLOBAL** *Industries, Inc.*

P.O. Box 629 514 W. Crawford Clay Center, KS 67432
Phone 785-632-2161 1-800-523-6993 FAX 785-632-5964