

10" AMERICAN / CENTURY II AUGER 10" "TD" / "TD-PLUS" AUGER

OWNER'S & OPERATOR'S MANUAL

Effective September 22, 2014

Publication No. 1012421

THIS MANUAL IS FOR UNITS WITH SERIAL NUMBERS OF 933548 OR HIGHER



Hutchinson/Mayrath

A Division of GLOBAL Industries Inc.

Hutchinson/Mayrath • P.O. Box 629 • Clay Center, KS. 67432
Ph. 785-632-2161 • Fx. 785-632-5964 • Toll Free 800-523-6993
www.hutchinson-mayrath.com



Hutchinson/Mayrath

A Division of **GLOBAL** Industries, Inc.

POLICIES AND PROCEDURES

- Prices:** Prices in effect at time of shipment will apply. Prices are subject to change without notice. All prices are F.O.B. Clay Center, Kansas. Orders shipped from locations other than Clay Center, Kansas will be subject to additional charges, such as back freight and/or additional freight.
- Service Charge:** A service charge will be assessed for all past due balances as permitted by state law not to exceed 1-1/2% per month.
- Minimum Order:** Processing and handling costs necessitate a minimum charge of \$15.00 net on all orders.
- Back Orders:** Back orders will be shipped as they become available. Contact Hutchinson/Mayrath Customer Service for alternative shipping options or if cancellation is desired.
- Damaged Goods:** It is the consignee's responsibility to check all shipments thoroughly upon receipt of goods. If any damage is discovered, it must be noted on the freight bill of lading before signing. The consignee must make necessary claims against the respective freight line. All damage claims must be submitted within 30 days of delivery receipt.
- Shortages:** All shortages must be noted at time of delivery. Shortages must be noted on the freight bill of lading before signing. Hutchinson/Mayrath must be advised of all concealed shortages upon discovery. Once notified of concealed shortages Hutchinson/Mayrath will advise corrective action to be taken.
- Return of Goods:** All returns must be approved by Hutchinson/Mayrath prior to shipment. All return requests will be issued a return authorization number. **NO RETURNS WILL BE ACCEPTED WITHOUT A RETURN AUTHORIZATION NUMBER AND PRIOR AUTHORIZATION FROM THE FACTORY.** All returns must be shipped prepaid. A 15% restocking charge will be applied to all returned merchandise. Custom Products may not be returned for credit. Only current products in new and salable condition may be returned. No safety devices may be returned for credit.
- Modifications:** It is the policy of Hutchinson/Mayrath to improve its product whenever possible and practical to do so. We reserve the right to make changes, improvements and modifications at any time without incurring the obligation to make such changes, improvements and modifications on any equipment sold previously.
- Limited Warranty:**
- (a) For a period of (1) year after receipt of goods by the original consumer buyer, Hutchinson/Mayrath will supply free of charge replacement parts for parts that prove defective in workmanship or material. Defective parts must be returned freight prepaid to a specified Hutchinson/Mayrath location. Only Hutchinson/Mayrath original repair parts may be used for warranty repairs.
 - (b) This limited warranty does not extend to parts designed to wear in normal operation and be replaced periodically; or to damage caused by negligence, accident, abuse or improper installation or operation.
 - (c) **GOODS NOT MANUFACTURED BY HUTCHINSON/MAYRATH CARRY ONLY THE MANUFACTURER'S WARRANTY.**
 - (d) **THIS UNDERTAKING IS IN LIEU OF ALL OTHER WARRANTIES, EXPRESSED OR IMPLIED, INCLUDING MERCHANTABILITY AND FITNESS FOR A PARTICULAR PURPOSE.**
- FAILURE TO FOLLOW THE INSTRUCTIONS CONTAINED IN THE OWNER'S & OPERATOR'S MANUALS AND THE ITEMS LISTED BELOW WILL RESULT IN THE VOIDING OF THIS LIMITED WARRANTY.**
- (1) Improper assembly, including failure to properly install all safety equipment.
 - (2) Improper installation.
 - (3) Unauthorized alternations of goods.
 - (4) Goods operated when obviously in need of repair.
 - (5) Use of unauthorized repair parts.
 - (6) Irresponsible operation.
 - (7) Used to handle materials other than free flowing, nonabrasive and dry materials, as intended.
 - (8) Damaged through abusive use or accident.
- Limitation of Liability:** BUYER AGREES THAT IN NO EVENT SHALL HUTCHINSON/MAYRATH HAVE LIABILITY FOR DIRECT DAMAGES THE EXCESS OF THE CONTRACT PRICE OF THE GOODS IN RESPECT OF WHICH CLAIM IS MADE. BUYER FURTHER AGREES THAT IN NO EVENT SHALL HUTCHINSON/MAYRATH ON ANY CLAIM OF ANY KIND HAVE LIABILITY FOR LOSS OF USE, LOSS OF PROFITS, OR FOR ANY INDIRECT, INCIDENTAL OR CONSEQUENTIAL DAMAGES.

GENERAL SAFETY STATEMENT

This manual was written with the safety of the operator and others who work with the equipment as our prime concern. The instructions presented will help the reader learn SAFE day to day work practices. We want you as our partner in safety.

It is your responsibility as an owner, operator or supervisor to know what specific safety requirements and precautions exist and to make these known to all other personnel working with the equipment or in the area, so that they too may safely perform their duties and avoid any potentially hazardous situations.

Please remember safety equipment provides important protection for persons around a grain handling system that is in operation. Be sure ALL the safety shields and protection devices are installed and properly maintained. If any shields or guards are damaged or missing, contact your dealer to obtain the correct items.

Avoid any alterations of the equipment. Such alterations may create a dangerous situation where serious injury or death may occur.

SAFETY ALERT SYMBOL

The symbol shown below is used to call your attention to instructions concerning your personal safety. Watch this symbol - it points out important safety precautions. It means "ATTENTION! Become alert! Your personal safety is involved!" Read the message that follows and be alert to the possibility of personal injury or death.



WARNING

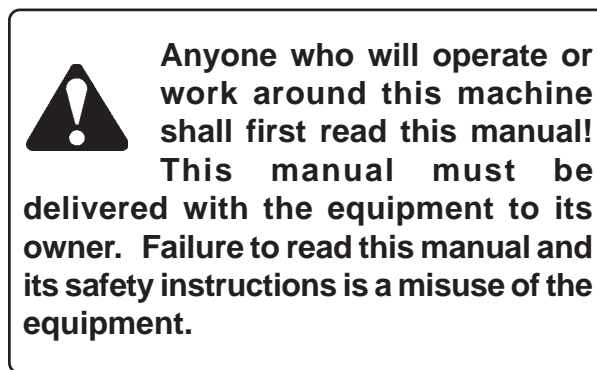

TABLE OF CONTENTS

| | |
|---|--------|
| General Safety Statements | 1 |
| Safety Symbol | 1 |
| Operator Qualification | 3 |
| Sign Off Sheet | 3 |
| Machine Inspection | 3 |
| TRANSPORTING AUGER | 4-5 |
| Hitching to Towing Vehicle | 4 |
| Alternate Hitch Safety Chain Installation | 4 |
| Moving Auger | 4-5 |
| PLACEMENT OF AUGER | 5-6 |
| Step 1 - Locate the Auger | 5 |
| Step 2 - Raising and Auger | 5 |
| Step 3 - Back into Working Position | 6 |
| WINCH INSTRUCTIONS | 6 |
| DESIGNATED WORK AREA | 6-7 |
| Rules for Safe Work Area | 6 |
| Work Area Diagram | 7 |
| OPERATING PROCEDURES | 8-13 |
| Start Up & Break In | 8 |
| Direct PTO Drive Information | 8-9 |
| Top Mounted Electric Motor Drive | 9-10 |
| Underslung Gas Engine Drive | 10-11 |
| Operating Capacities | 11 |
| Shut Down | 12 |
| Lockout | 12 |
| Relocation of Auger | 12-13 |
| TROUBLE SHOOTING | 13 |
| LUBRICATION AND MAINTENANCE | 14-15 |
| Gearbox | 14 |
| PTO Driveline | 14 |
| Enclosed Drive | 14 |
| Friction Type Winch | 14 |
| Belt Adjustment | 14 |
| Bearings | 15 |
| ASSEMBLY INSTRUCTIONS | 16-40 |
| PARTS LIST | P1-P16 |

SERIAL NUMBER

To ensure efficient and prompt service, please furnish us with the model and serial number of your auger in all correspondence or other contact. The serial plate is located on the winch mount on the lower section of auger housing.

RIGHT AND LEFT DESIGNATION

When determining which is the left or right hand side of the unit, it is as if a person were standing at the intake end and looking toward the discharge end.

OPERATOR QUALIFICATIONS

Operation of this Portable Conveyor shall be limited to competent and experienced persons. In addition, anyone who will operate or work around a Portable Conveyor must use good common sense. In order to be qualified, he must also know and meet all other requirements, such as:

1. Some regulations specify that no one under the age of 16 may operate power machinery. This includes Portable Conveyors. It is your responsibility to know what these regulations are in your area or situation.
2. Current OSHA regulations state in part: "At the time of initial assignment and at least annually thereafter, the employer shall instruct every employee in safe operation and servicing of all equipment with which the employee is, or will be involved."*
3. Unqualified persons are to stay out of the work area, as shown in the work area diagrams. See Page 7.
4. A person who has not read and understood all operating and safety instructions is not qualified to operate the machine.

***Federal Occupational Safety & Health Standards\ for Agriculture Subpart D, Section 1928.57 (a) (6).**

MACHINE INSPECTION

After delivery of your new conveyor and/or completion of assembly and before each use, inspection of the machine is mandatory. This inspection should include, but not be limited to:

1. Check to see that all guards listed in the assembly instructions are in place, secured and functional. PTO driveline outer shields must rotate easily.
2. Check all safety signs and replace any that are worn, missing or illegible. The safety signs are listed on page P-1 and P-3. Safety signs may be obtained from your dealer or ordered from the factory.
3. Check winch and cable for security and operation. There should be at least three complete wraps of cable around winch drum in full down position. Cable anchor on winch drum must be tight.
4. Are all fasteners tight?
5. Are drive belts properly adjusting? (See Maintenance Section.)
6. Check oil levels in gearbox and enclosed drive unit. (See Maintenance Section.)

SIGN OFF SHEET

As a requirement of OSHA, it is necessary for the employer to train the employee in the safe operation and safety procedures with this conveyor. We include this sign off sheet for your convenience and personal record keeping.

| DATE | EMPLOYER SIGNATURE | EMPLOYEE SIGNATURE |
|------|--------------------|--------------------|
| | | |
| | | |
| | | |
| | | |
| | | |
| | | |
| | | |
| | | |

TRANSPORTING AUGERS

TRANSPORT: Moving the Auger with the Towing Vehicle to or from the Work Area.

1. HITCHING TO TOWING VEHICLE INSTRUCTIONS.

Make certain the hitch pin is securely attached and an alternate hitch safety chain is secured to the auger and towing vehicle. Check to see that the hitch is securely attached.

Never raise the intake end higher than is necessary to attach to a towing vehicle. Weight transfers rapidly to the head end when the intake is raised.

NOTE: Empty machine before moving to prevent upending.

Never stand between tractor and machine when hitching unless all controls are in neutral and the brakes locked.

| Auger Length | 31' | 35' | 41' | 51' | 57' | 61' | 65' | 71' |
|-------------------|--------|--------|---------|--------|--------|--------|--------|--------|
| Transport Height* | 11'-0" | 12'-2" | 12'-10" | 14'-0" | 14'-2" | 14'-6" | 14'-6" | 17'-9" |

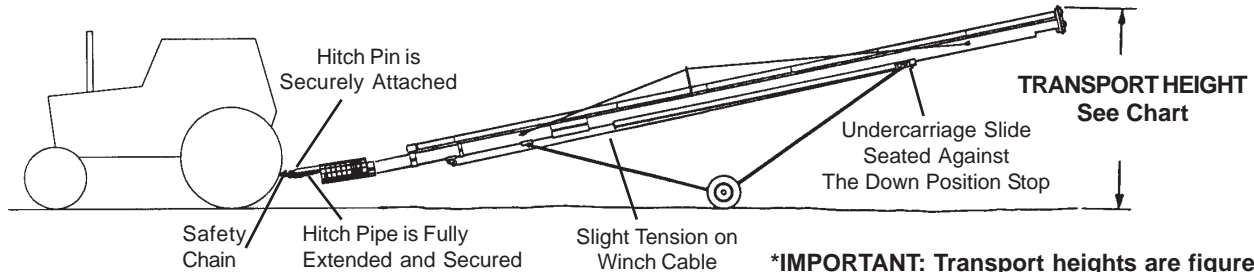

***IMPORTANT:** Transport heights are figured with auger attached to towing vehicle with a drawbar height of 1'-6". When the auger intake is resting on the ground, add 1'-6" to transport height of the auger to achieve the overall auger height.

ALTERNATE HITCH SAFETY CHAIN

An auxiliary attachment system (safety chain) is required to retain the connection between towing and towed machines in the event of separation of the primary attachment system.

The safety chain should be routed through the intake chain safety screen and around the bearing support at the lower end of the intake flight. Then route the chain through the chain support on the hitch pipe.

A clevis or intermediate chain support should be fastened to the tractor drawbar no farther than 6" from the hitch pin.

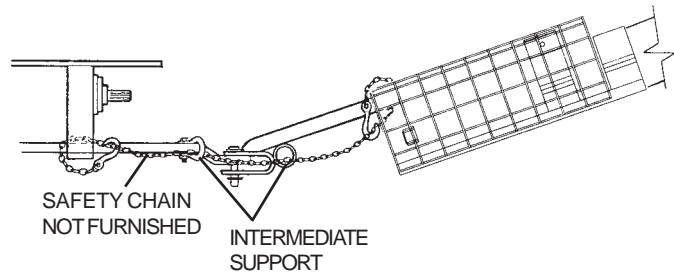

2. MOVING AUGER

Moving your portable auger requires careful planning. A route plan should be considered beforehand to avoid dangerous obstacles and loss of time.

Always transport your auger in the full down position. The lift arm of the undercarriage should be seated against the down position stop with slight tension on the winch cable and at least 3 complete wraps of cable around the winch drum.

Never allow persons to stand underneath or ride on the auger when moving the auger. Make certain everyone is clear of the work area before moving.

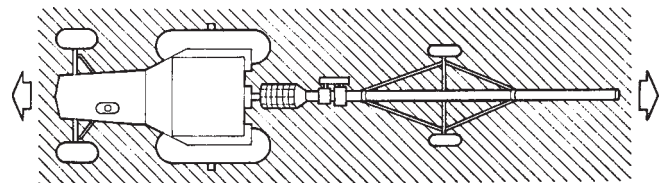

WHEN MOVING AUGER, HAZARD AREA - KEEP OUT

Do not transport the auger at speeds in excess of 20 MPH and comply with your state and local regulations governing marking, towing and maximum width. Observe safe driving and operating practices.



Be alert to overhead obstructions and electrical wires, particularly if towing height is greater than 13'-6". Failure to do so may result in electrocution. Lower auger well below level of power lines before moving. Maintain at least ten (10) feet of clearance. Page 4 contains a chart showing the height of each portable auger in the lowered transport position. Check the chart to determine the height of your auger.

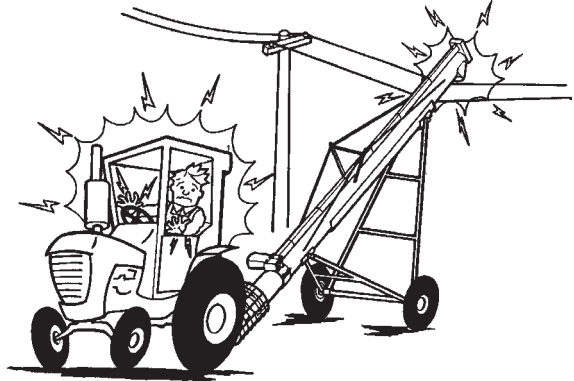

PLACEMENT OF AUGER - FILLING GRAIN BIN

Placement - Move the auger into its working position with a towing vehicle.

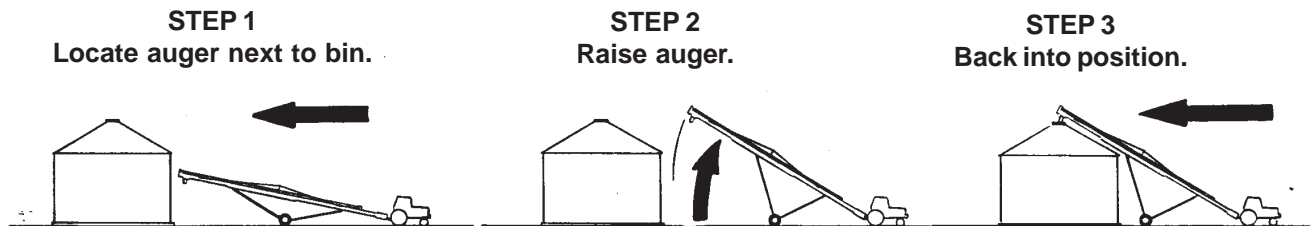

STEP 1

Locate the auger as close as possible to the bin or other structure. Move auger slowly towards working position with towing vehicle—not by hand. When moving the auger towards the working position leave adequate room for convenient path for loaded vehicles to reach the auger intake area.



Make certain everyone is clear of the work area when moving the auger. To prevent tip-over when backing, avoid rolling over any obstructions, also avoid steep slopes. If the auger is to sit on a slope, approach the bin up hill. Avoid moving the auger at right angles to a slope.



Make sure entire area above auger and in line of travel is clear of overhead obstructions and electrical wires. Failure to do so may result in electrocution. Maintain at least ten (10) feet of clearance. Electrocution can occur without direct contact.

STEP 2

Raise the auger only high enough to allow minimum clearance above the bin.

TO RAISE THE AUGER WITH HAND WINCH:

Turn the handle, clockwise (pull cable onto winch drum). There should be a clicking sound.

NOTE: The winch is equipped with a brake that is actuated by turning the handle. The brake is designed to hold the load whenever the handle is released.

NOTE: Observe the cable as it is winding onto the winch drum. The cable should roll up on the drum evenly; avoid cable build-up on one side of the drum.



Keep hands away from winch drum during operation.

STEP 3

Back auger slowly into working position with towing vehicle. **NEVER MOVE AUGER BY HAND, USE A VEHICLE.**

DO NOT ATTEMPT TO INCREASE AUGER HEIGHT BY POSITIONING WHEELS ON LUMBER, BLOCKS OR BY OTHER MEANS.

Once in place the wheels should be chocked on both sides of auger so it will not roll when disconnected from the towing vehicle.

When releasing from the towing vehicle, test the intake end for downward weight. **LOWER IT SLOWLY TO THE GROUND. NOTE: Weight transfers rapidly to the head end if the intake is raised above the tow bar, particularly when the auger is in a raised position.**

Remove bolt from hitch and fully retract hitch pipe. If a hopper is to be used, install at this time. Lower the auger until the auger discharge is directly over bin opening.

TO LOWER AUGER WITH HAND WINCH:

Turn the handle counter-clockwise; there will be no clicking sound. To stop while lowering the auger, turn the handle clockwise until you hear two clicks to lock brake. (About 6" movements of the handle.)

The auger should be anchored at the intake end and/or supported at the discharge end. This will prevent auger from tipping when weight transfers to top end as auger empties. It is a good practice to tie the discharge end of the auger to the bin or grain storage structure to prevent possible wind damage. Remember to untie the auger before attempting to move.

NOTE: When discharging into a grain spreader, always maintain at least 12 inches of space between the auger discharge and the spreader.

WINCH INSTRUCTIONS

HAND WINCH OPERATION (FRICTION TYPE)

Check the handle assembly on your auger to determine that it has been assembled correctly. See assembly section. There should be a locknut attached to the end of the winch shaft to prevent inadvertent removal of the winch handle.



Never fully extend the cable and always keep three complete turns of cable around winch drum.

Never operate winch with wet or oily hands and ALWAYS use a firm grip on the handle.

SAFETY REMINDERS

- (1) Operator must pay attention during raising and lowering auger.
 - (A) Watch cable to see if it is coiling properly onto winch drum evenly.
 - (B) Keep hands away from winch drum during operation.
 - (C) Don't use hands to guide cable onto winch drum during winch operation.
 - (D) Don't allow auger to become hung up on other structures during lowering.
 - (E) Don't continue to attempt to raise auger after slide reaches stop.

See the owner's manual and parts list for the winch that is included with this manual for additional winch information.

DESIGNATED WORK AREA

Before starting the auger, a designated work area should be established and properly marked. The following diagrams will show the manufacturers designated work areas. These areas shall be marked off with colored nylon or plastic rope hung as portable barriers to define the designated work areas.

RULES FOR SAFE WORK AREA



Under no circumstances should persons not involved in the operation be allowed to trespass into the work area.



It shall be the duty of all operators to see that children and/or other persons stay out of the work areas! Trespass into the work area by anyone not involved in the actual operation, or trespass into a hazard area by anyone, shall result in an immediate shutdown by the operator.



It shall be the responsibility of all operators to see that the work area has secure footing, is clean and free of all debris, and tools which might cause accidental tripping and/or falling. It shall also be their responsibility to keep the work area clean and orderly during the operation.



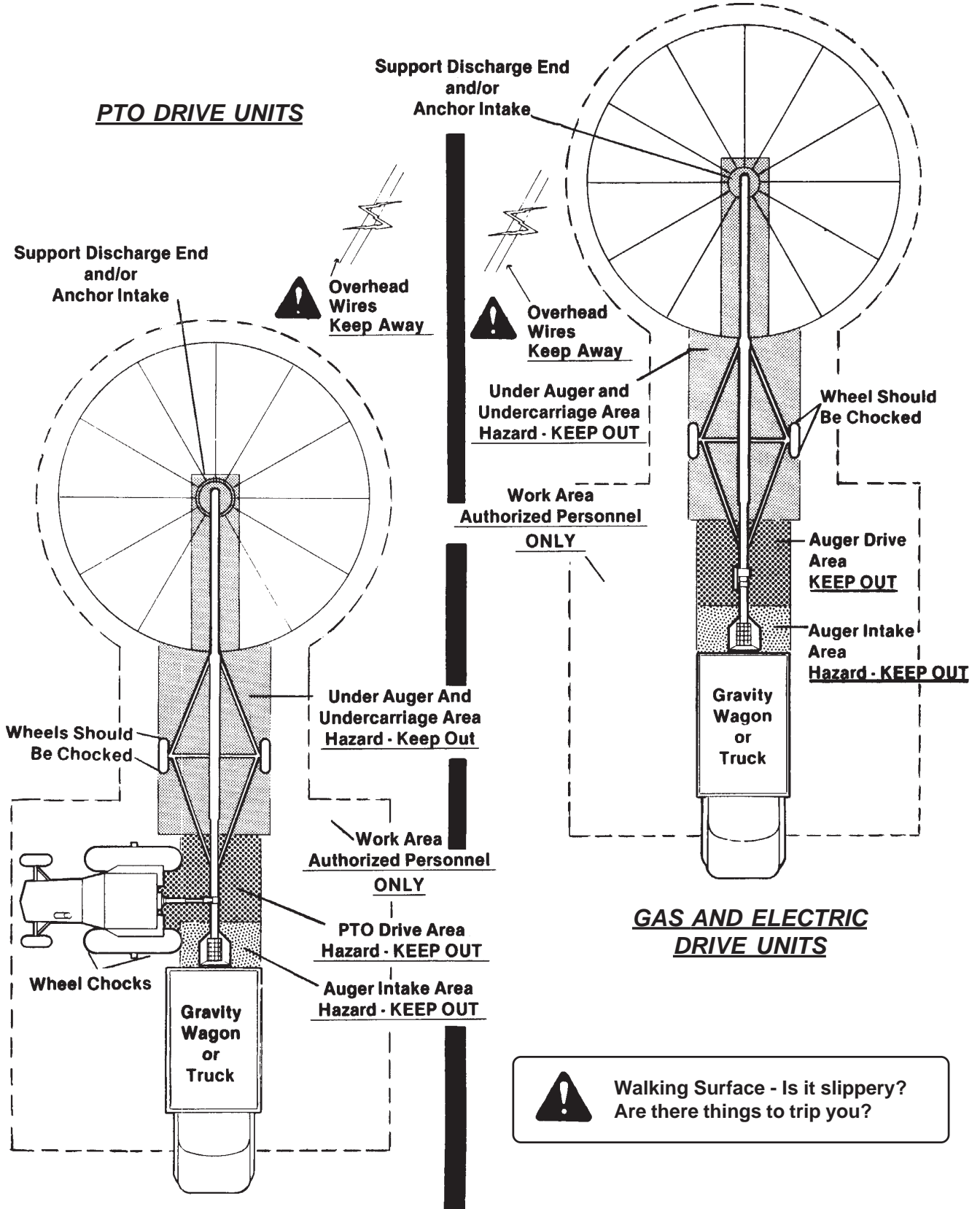

START-UP AND BREAK-IN INFORMATION

It is essential to inspect your drive before adding power and know how to shut down in an emergency. During the operation of your auger, one person shall be in a position to monitor the operation. Any screw conveyor when it is new or after it sets idle for a season should go through a "break-in" period. The auger should be run at partial capacity until several hundred bushels of grain have been augered to polish the flighting assembly and tube. When the screw and tube are polished and smooth the auger can be run full. Never operate the auger empty for any length of time as excessive wear will result. If at all possible, do not stop or start the auger under load, especially before the flight and tube become well polished, as this may cause the auger to "freeze-up".

During the initial start-up and break-in period, the operator shall be aware of any unusual vibrations or noises that would indicate a need for service or repair.



Keep all safety shields and devices in place.

Keep hands, feet and clothing away from moving parts.

The operator should have a full view of the auger work area and check that all personnel are free from designated work area before adding power.

Proper auger flight speed is important for efficient operation of the auger.

1. If the flight speed is in excess of what is recommended, excessive wear will result.
2. If the flight speed is slow and the auger flighting is permitted to "load-up", high torque will be required to turn the auger flighting, and damage to the auger can result. Under these conditions, use an optional control gate to control the amount of grain fed into the auger.

DIRECT PTO DRIVE INFORMATION

Only use a tractor with 540 RPM Power Take-Off. The standard direct PTO may be driven from either side (as explained in the Direct PTO Drive Assembly Section). If the tractor output PTO shaft is operated at 540 RPM, the auger will have a 540 RPM auger flight speed.

NOTICE: The PTO driveline furnished with the auger is equipped with a "Spring-Lok" coupler at the tractor end. This type coupler is spring loaded and will fit the standard 1-3/8" x 6" spline PTO output shaft from a tractor.

See that the PTO driveline is securely attached and the retaining balls of the "Spring-Lok" coupler lock into the ring groove of the tractor PTO output shaft. Check this by trying to pull the driveline off of the tractor PTO output shaft.

CHECK THE FOLLOWING BEFORE ADDING POWER:

1. Be certain the PTO driveline is securely attached to the auger and the tractor.
2. Never use a PTO driveline without a rotating shield in good working order that can be turned freely on the shaft.

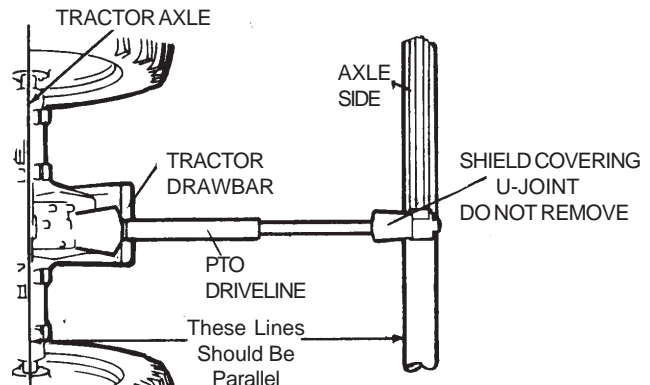

PTO DRIVE INFORMATION - CONT.

3. Align PTO driveline with tractor. The PTO driveline furnished with the auger is a pin stop type, that is, the two telescoping sections will not separate. It is a good practice to operate the PTO driveline in as short a configuration, as possible. Keep the PTO driveline in as straight a line as possible during operation. When connecting tractor and auger, always make sure the tractor axle and side of auger are parallel.

4. If the tractor and auger are on unlevel ground or at different levels, place them so the center line of the tractor and the gearbox shaft are parallel.



Before engaging PTO, be sure the PTO driveline shields turn freely on shaft.

KEEP THE U-JOINT ANGLES EQUAL.

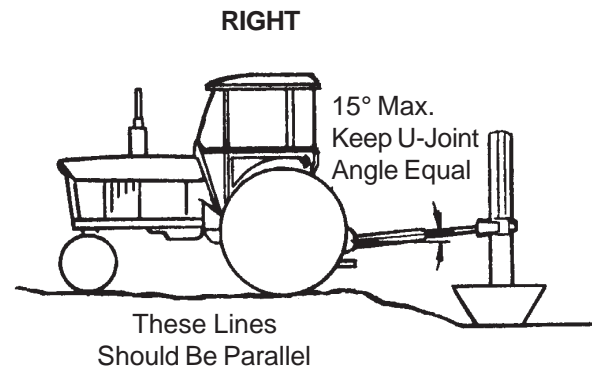
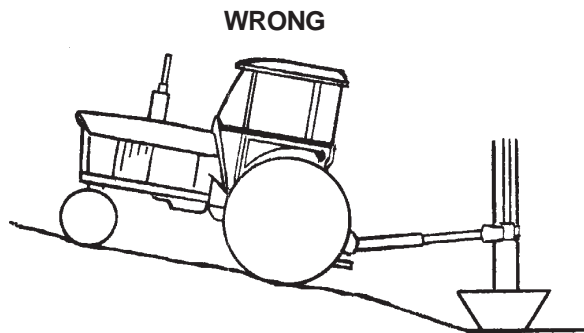

TO START AUGER:

1. Before starting the tractor, be certain power to PTO is off.
2. Start tractor.
3. Engage PTO at a slow RPM, then work up RPM to recommended speed.



IMPORTANT: Engage PTO at a slow RPM to minimize shock loads. Then work up RPM to recommended speed.

TOP MOUNTED ELECTRIC MOTOR DRIVES:

Always use a motor with required H.P. suggested in charts shown on page 10. Use motor that operates at 1750 RPM.

Electric motors and controls shall be installed by a qualified electrician and must meet the standards set by the National Electrical Code and all local and state codes. Reset and Motor Starting Controls must be located so that the operators have full view of the entire operation.

A magnetic starter should be used to protect your motor when starting and stopping. It should stop the motor in case of power interruption, conductor fault, low voltage, circuit interruption or motor overload. Then the motor must be restarted manually. Some motors have built-in thermal over-load protection. If this type motor is used, use only those with manual reset.

NOTE: Motor pulleys are not furnished with the auger.

OPERATING PROCEDURES

TOP MOUNTED ELECTRIC MOTOR DRIVE - CONT.

The horsepower recommendations are for augering reasonably dry grain at varying angles. High moisture grain (above 15%) will require greater power and maximum possible capacity will be less with high moisture grain than with dry grain.

Disconnect power before resetting motor overloads. Make certain electric motor is grounded.

CHECK THE FOLLOWING BEFORE ADDING POWER:

1. Check that belt guard is in place, secured and functional.

TO START AUGER

1. Start electric motor before conveying grain.

TO STOP AUGER

1. Let auger empty of grain before stopping.
2. Shut off electric motor and lockout.

| Horsepower Recommendations 10" Augers Use 4.0" O.D. pulley on motor for 467 RPM Auger Speed | |
|--|-------------------|
| Length | Horsepower |
| 31' | 7 1/2 to 10 hp |
| 35' | 10 hp |
| 41' | 10 to 15 hp |
| 51' | 15 to 20 hp |
| 57' | 15 to 20 hp |
| 61' | 15 to 20 hp |
| 65' | 20 to 25 hp |
| 71' | 20 to 25 hp |

UNDERSLUNG GAS ENGINE DRIVE FOR 31', 41' & 51' MODELS ONLY

Always use a Gas Engine with required H.P. suggested in the chart below.

The horsepower recommendations are for augering reasonably dry grain at varying angles. High moisture grain (above 15%) will require greater power and maximum possible capacity will be less with high moisture grain than with dry grain.

| Auger Lengths | Motor Horsepower Required | Gearbox Ratio | Gearbox Sheave | *Motor Engine Sheave | Suggested Auger Flight Speed |
|----------------------|----------------------------------|----------------------|-----------------------|-----------------------------|-------------------------------------|
| 31', 41' & 51' | 18 hp | 1.5 to 1 | 15" O.D. | 3.5" O.D. | 467 rpm |

Based on an engine with 3000 RPM output.

*Engine sheave is not furnished with auger.
O.D. Outside Diameter

CHECK THE FOLLOWING BEFORE ADDING POWER:

1. The belt from the gearbox pulley to engine pulley must be adjusted for proper belt tension. Adjustment is made by using the motor mount adjustment rod.
2. The underslung mount should be able to pivot on the gearbox pivots to allow the motor mount to set level.
3. Check that all belt guards are in place, secured and functional.

Never attempt to adjust or service the engine or any other drive components while it is in operation. Shut down and allow engine to cool before filling with fuel. Consult the engine manual for engine information.

UNDERSLUNG GAS ENGINE DRIVE FOR 31', 41' & 51' MODELS ONLY

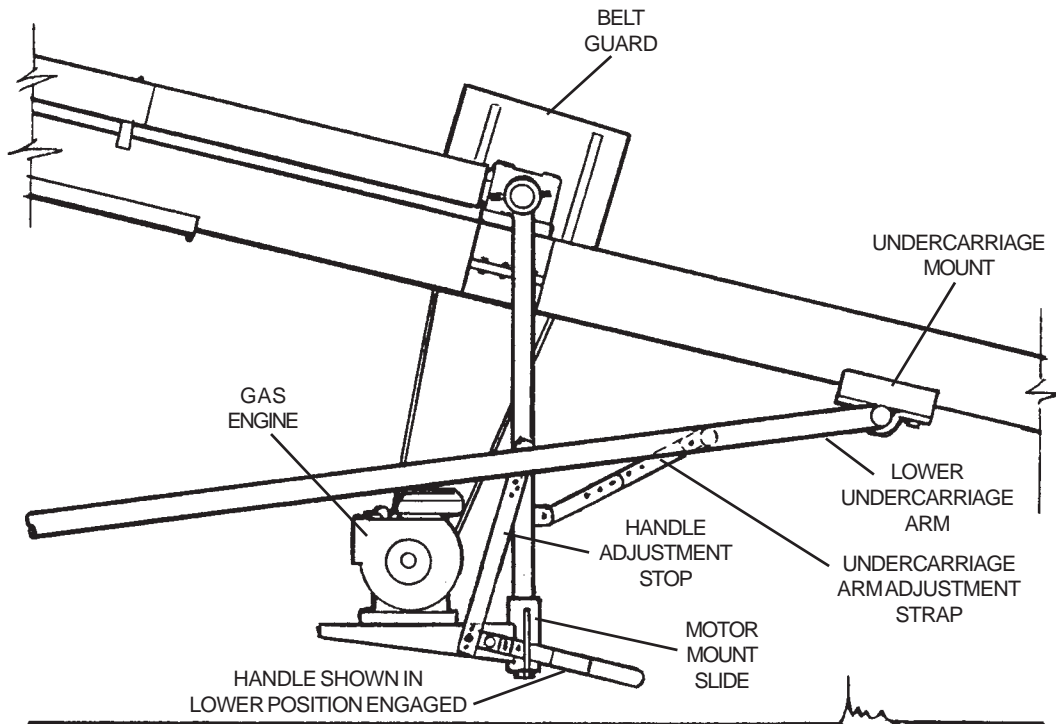

TO START AUGER:

The motor mount is equipped with a handle for sliding the engine to tighten the drive belts between the gasoline engine pulley and gearbox pulley.

1. Before starting engine be certain that the handle is in the upper position and disengaged. The belts should be loose.
2. Start the engine and bring up to working R.P.M.
3. Move the handle to the side, then slowly slide down and lock in the lower engaged position.

NOTE: If the drive belts slip during grain conveying operations, empty and stop the auger. Then, lockout the drive and adjust the belt tension by moving the adjustment straps to another position.

TO STOP AUGER:

1. Let auger empty of grain before stopping.
2. Disengage by moving the handle to the side, then lifting up and lock in the upper position.
3. Shut off engine and lockout by removing ignition key, spark plug wire or spark plug.

OPERATING CAPACITIES

10" - 4500 Bushels per hour

The results or capacities of screw conveyors or augers can vary greatly under varying conditions. Different materials, moisture content, amounts of foreign matter, angle of operation, methods of feeding and speed all play a role in the performance of the auger. An auger operating at a 45° incline could be cut 20% in capacity over an auger operating horizontally. Twenty-five (25%) moisture could cut capacity back by as much as 40% under some conditions. If an inclined auger has one foot of grain over the inlet flight, it will probably get better capacity than if it had only a one inch covering. On the other hand, an auger in the bottom of a cone shaped pit or under a bulk tank with maybe four feet or more of grain on top of it may be overfed. This overfeeding would be caused from the weight of the grain over the intake forcing more into the auger than it can efficiently move. The result would be an increased horsepower requirement, extra strain on the drive line, and possibly a complete stall out. Under the "extra" pressure conditions, a control gate should be used.

SHUTDOWN**A. NORMAL SHUTDOWN**

When shutting down the auger make certain that the hopper and auger are empty before stopping the unit. Before the operator leaves the work area, the power source shall be locked out. (See Lockout.)

B. INTERMITTENT OPERATION SHUTDOWN

NOTE: When augers are stopped and restarted under full load, it may result in damage to the auger. Consideration should be given to the proper size auger for a batch drying or any intermittent type operations. Using a large diameter auger and reducing its load level will be far better than subjecting a smaller diameter auger to high loads. If an auger is kept from absolute filling, it will make start-up easier and will convey more efficiently.

C. EMERGENCY SHUTDOWN

Should the auger be immediately shut down under load, disconnect and lockout the power source. Clear as much grain from hopper and auger as you can. Reconnect power source and clear auger. Never attempt to start when full.

NOTE: Starting the unit under load may result in damage to the auger. Such damage is considered abuse of the equipment.

LOCKOUT

If the operator must leave the work area, or whenever servicing or adjusting, the auger must be stopped and the power source turned off. Precaution should be made to prevent anyone from operating the auger when the operator is absent from the work area.

DIRECT PTO DRIVE: Remove ignition key or coil wire from power source. (If this is impossible, remove the PTO driveline shaft from the work area.)

TOP MOUNTED ELECTRIC DRIVE: A main power disconnect switch capable of being locked only in the off position shall be provided.

UNDERSLUNG GAS ENGINE DRIVE:

1. For engines with rope or crank start- remove spark plug wire or spark plug.
2. For engines with electric start - remove ignition key, spark plug wire or spark plug.

RELOCATION OF AUGER

When grain conveying operation is completed, the auger should be moved away from the bin and lowered. The auger then can be moved to a different bin for more conveying operations or cleaned up and stored.

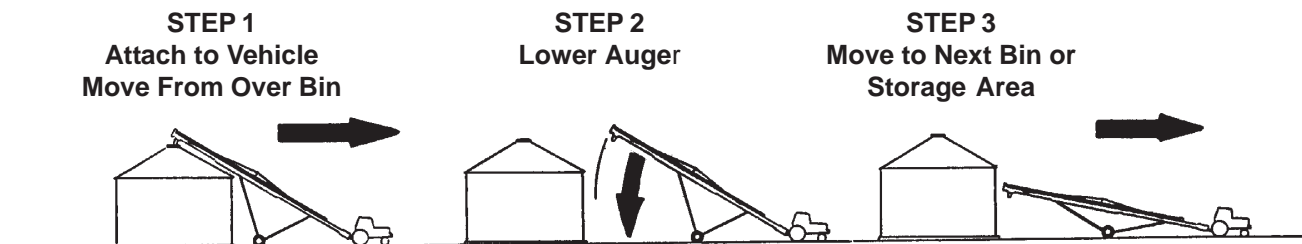
**Step 1**

- A. Empty all grain from the auger and clean up area.
- B. Untie any anchors or remove all supports.
- C. Disconnect the power source.

Direct PTO Drive - Disconnect PTO driveline from tractor and place in support provided for transporting.

Top Mounted Electric Drive - Unplug electric motor, wind up electric cables.

NOTE: The bracket pin must be in place to hold the PTO driveline in the support during transporting.

- D. Raise the auger so the discharge spout is clear of bin opening. See Auger Raising Instructions on page 5.
- E. Remove hopper from auger intake and secure hitch in place with bolt and nut.
- F. Lift the auger intake and hitch to the towing vehicle. See Hitching Instructions on page 4.
- G. Remove wheel chocks.
- H. Move auger slowly away from the bin with towing vehicle—**NOT BY HAND.**

RELOCATION OF AUGER - CONT.

Step 2

A. Lower auger immediately after clear of bin or storage structure. See Winch Lowering Instructions on page 6.

IMPORTANT: Lower the auger, even if relocating to a bin in the immediate area.

Step 3

A. Move the auger to next bin or storage area. We recommend that the auger be stored in the full down position with intake end anchored.

B. Inspect the auger as outlined in the "Machine Inspection Section" on page 3.

TROUBLE SHOOTING

LOW CAPACITY

The auger may not be getting enough grain. Check to see the intake has not "bridged over" restricting the flow.

The exposed flighting at the auger intake should be covered with grain to achieve maximum capacity.

Check auger speed. Refer to page 10. A slow speed (below recommended speed) will result in low capacity.

AUGER PLUGS

The auger may be getting too much grain where it is "jamming" inside the housing. An optional control gate may be necessary at the intake end.

On motor drive augers, the motor may be too small or wired improperly.

If wet grain or other hard to move material is being augered, use a larger size motor than recommended for normal use.

Is the auger free of any foreign material, such as sacks, tarp corners, etc.? A plug of the discharge end will cause an auger plug.

On electric powered units, check to see if all belts are lined up and tensioned properly.

EXCESSIVE AUGER NOISE

Damage may have occurred to the auger flighting, thus causing noise. Damage usually occurs because of foreign material having been run through the auger. It may be necessary to remove the flighting for inspection.

IMPORTANT:

An auger should be frequently checked and serviced to operate freely. Keep all guards and shields in place. Replace any that are damaged or lost. An auger should be run partially full for several hundred bushels to polish the flighting when it has not been used for an extended period of time. An auger with flighting that has not been polished in this manner requires greater horsepower, and damage to the drive and/or flighting can result if overloaded.

Our augers are well made and we are proud of our line of equipment. We would like you, as our customer, to do your part in using caution and good judgement in using our equipment, as well as any other machinery. Any parts for replacement should be replaced with parts of the same type and size. Do not modify or alter any of the auger components.

For economical and efficient operation of your auger, maintain regular and correct lubrication. Neglect leads to reduced efficiency, excessive wear and needless down time.



Keep all safety shields and devices in place. Never clean adjust or lubricate a machine that is in operation.

The following will detail the parts needing lubrication and the various conditions which determine the time span.

GEARBOX

The gearbox is shipped **without oil**. At field assembly of auger, 90 E.P. (non-foaming) **oil is to be added to the gearbox until half full**. Check and maintain the level regularly.

ENCLOSED DRIVE LUBRICATION

The enclosed drive is located at the discharge end of the auger housing and is shipped **without oil**. **Oil is to be added to the unit during field assembly of the auger**. Oil will dissipate under normal operating conditions, therefore the oil level should be checked regularly. Add 90 EP (non-foaming) oil until the level of the oil reaches the check port.

DO NOT ADD MORE OIL THAN RECOMMENDED. ADDITIONAL OIL MAY DAMAGE THE SEALS OR BE FORCED OUT THROUGH THE VENTED PLUG.

For lubrication in normal operating temperature between 40° F to 120° F, we recommend the use of non-foaming, multi-purpose gear oil, SAE 90 weight. For temperatures below 40° F, use SAE 80 weight oil. Use grade commercially available for automotive differentials. Extra pressure additives may be of value in severe applications.

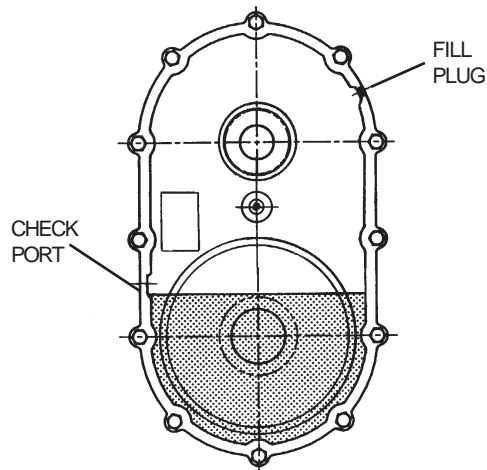

PTO DRIVELINE

Augers equipped with PTO driveline, should have the u-joints lubricated at approximately **ten (10) hour** intervals with SAE multipurpose type grease.



Before engaging P.T.O., be sure that PTO driveline shields turn freely on shaft.

The PTO driveline is equipped with a shear bolt at the tractor connection. The shear bolt protects the auger from damage if the auger becomes plugged or subjected to high loads. It is important to use the correct replacement bolt of the proper size and strength to insure that the shear device will protect the auger and operator. For 10" augers, order replacement shear bolt, Part No. 33046 - 5/16" - 18 x 1" long grade 5 bolt. Extra shear bolts are provided with auger.

FRICITION TYPE WINCH

The following lubrication checks should be made to the winch periodically.

The auger should be in the lowered position with undercarriage lift arm slide against the upper head stop when this inspection is being performed. Refer to operating and maintenance instructions furnished with your winch for proper inspection methods.

1. All gears should have a film of grease on them at all times.
2. The following parts must be wet with oil at all times:
 - (A) Two bushings located at ends of drum shaft.
 - (B) The ratchet pawl pivot.

IMPORTANT: Do not get oil or grease on brake disc faces (located between ratchet gear, brake hub and pinion shaft.)

3. Check brake disc, if worn to less than 1/16 of an inch thick, cracked or broken, replace both discs.

BELT ADJUSTMENT

On drives that are powered by belts, the belt tension will need periodic adjustment. See the operating procedures section for belt adjustment location.

BEARINGS

Drive Shaft Bearing

All drive shafts are supported by self-aligning, sealed ball bearings, which have been packed at the factory and require no further lubrication. There is no adjustment to be made to the bearings, but to check that the retainers are firmly fastened to the bearing stand. Also, check that the setscrews in the lock collars are tight against the drive shaft, securing the lock collars to the drive shaft.

IMPORTANT: The complete drive shaft must be shielded with drive shaft covers during operation.

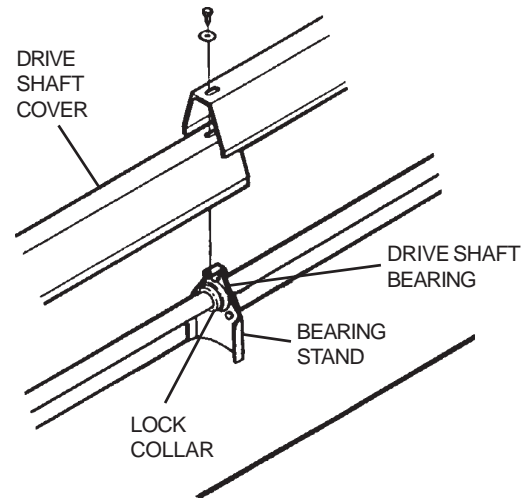

Intake Guard Bronze Bearing

Every auger has a bronze-with-graphite bearing at the intake end. This bearing requires no lubrication. If wire guard is damaged, replace the intake guard.

Undercarriage Axle Spindle Bearing

Tapered roller type bearings are standard for 10" augers and should be repacked with grease and adjusted annually or as needed, determined by usage.

Care must be used in dismantling the tapered roller bearings. First, remove the dust cap by prying around its edges. Remove the cotter pin, slotted nut and flat washer. Carefully remove the hub and bearings from the spindle. Inspect all parts for wear or damage and replace with new ones, if necessary.

When reassembling the hub, repack both bearing cones with grease and fill the hub cavity 1/3 full. Place inner bearing assemblies into the hub, and then press grease seal into hub and carefully reinstall the hub on the spindle. When placing hub on spindle be careful not to damage the lip of the grease seal. Install outer bearing assembly into the hub, and replace flat washer and slotted nut. Tighten the slotted nut to seal the bearings until the hub binds as you rotate hub. Back off the slotted nut to the next slot and pin with a new cotter pin. Use a 5/32" cotter pin 1-1/4" long. Replace dust cap.

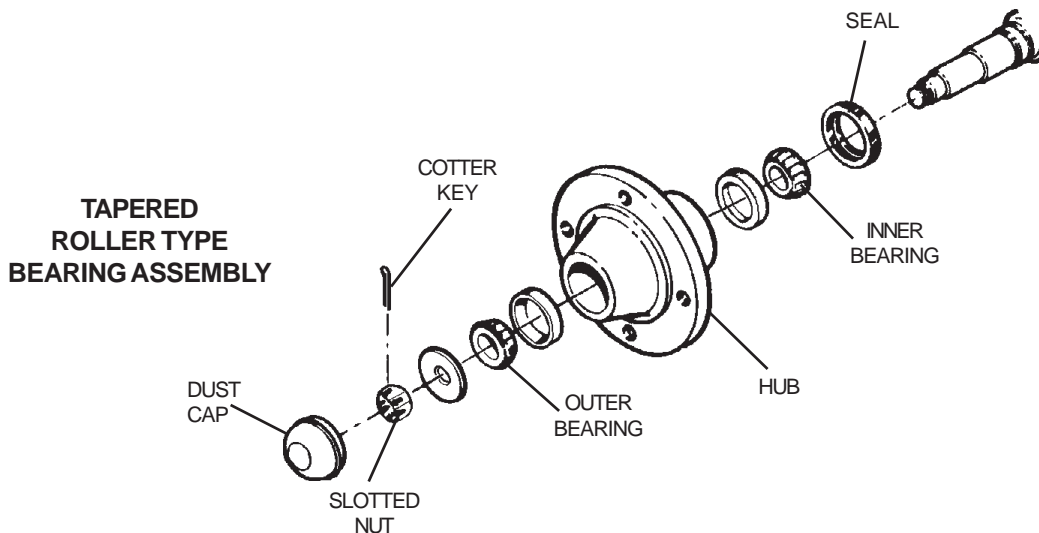

ASSEMBLY INSTRUCTIONS

AUGER HOUSING LAYOUT

Choose an area of open level ground accessible to chain hoist or other lifting device where the auger may be laid out full length. Arrange the tube sections in their relative positions. See Fig. 1. For ease of assembly, place the tubes on stands or blocks so the drive housings are off the ground with the tubes level. NOTE: Orient the 25' 10-1/4" tube sections so the decals are right side up and readable.

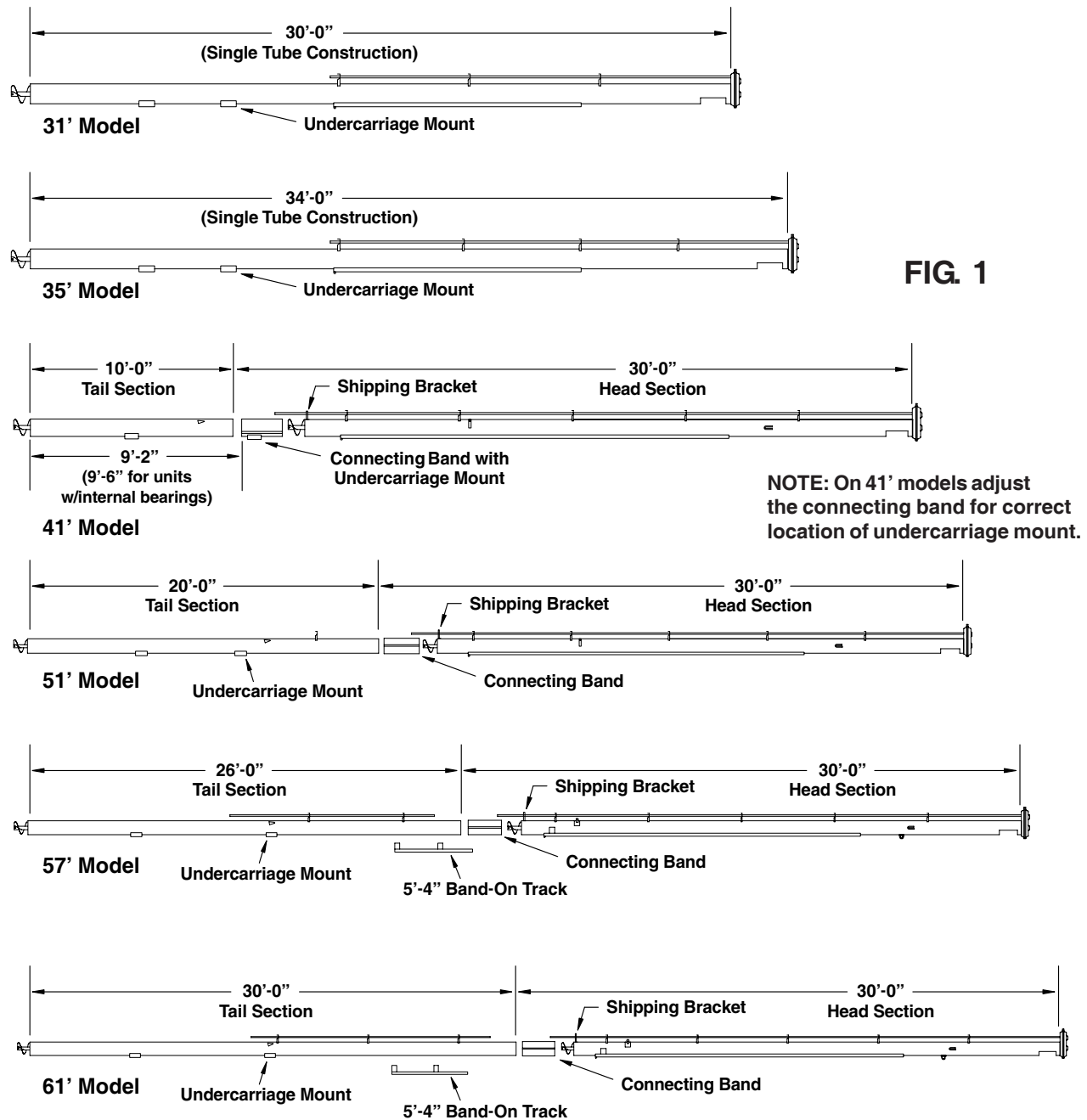

FIG. 1

LAY OUT THE AUGER TUBE - (CONT.)

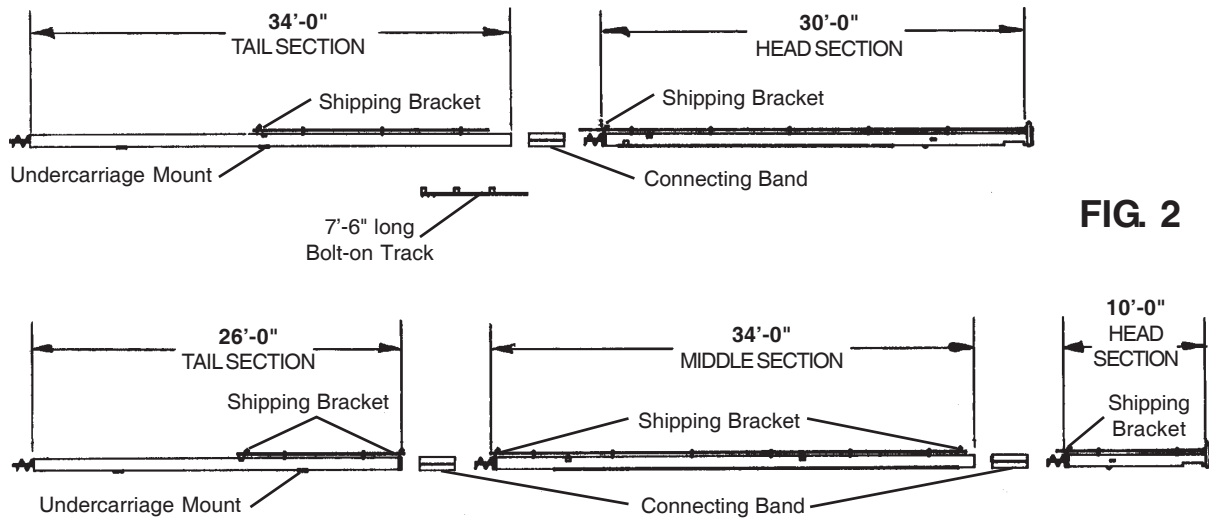

FIG. 2

SHIPPING BRACKET

Remove the shipping bracket from the drive shaft. See Figure 1 or 2 for location of shipping bracket for size of auger you are assembling.

FLIGHT AND AUGER HOUSING SECTIONS ASSEMBLY

NOTE: Units with optional internal flight bearings, go on to page 18 for auger flight and auger housing sections assembly.

Step 1. Bolt the sections of auger flighting together, using two 1/2" x 3" (grade 8) black hex head capscrews and side depress locknuts. The lower section of flighting will lap the upper section flighting about one inch on the side toward the auger outlet. See Figure 3.

Step 2. Install a 1/4" x 1-1/2" square key into the end of each drive shaft. Slide a 1" to 1" drive shaft coupler onto the end of one of the drive shafts.

Step 3. As you slide the head section and bottom section of auger housings together, connect the head and bottom sections of the drive shaft together.

Step 4. Be sure the auger housings are pushed tight together and the connecting band is spaced so it is about half way on each auger housing section. Tighten the connecting band in place using (6) 3/8" x 1-1/2" long (grade 5) hex head capscrews and nuts.

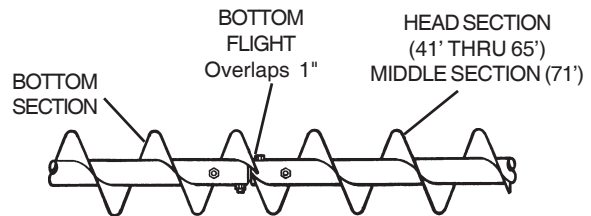
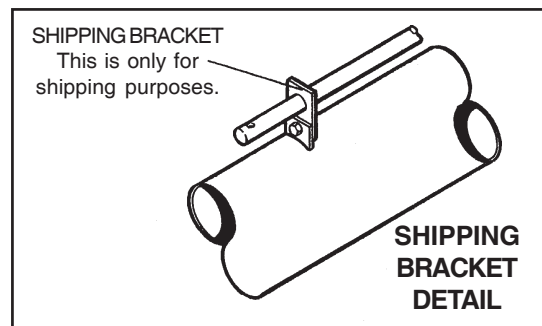

FIG. 3

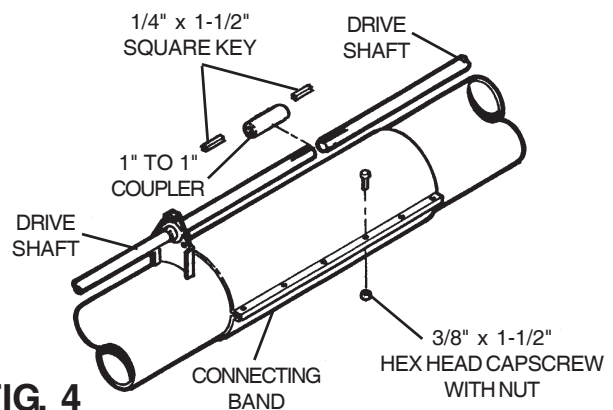

FIG. 4

ASSEMBLY INSTRUCTIONS

AUGER FLIGHT AND AUGER HOUSING SECTION ASSEMBLY FOR UNITS WITH OPTIONAL INTERNAL FLIGHT BEARING

Step 1. Install a 1/4" x 1-1/2" long square key into the end of each drive shaft. Slide a 1" to 1" drive shaft coupler onto the end of one of the drive shafts.

Step 2. As you slide the auger housing section together, guide the drive shaft into the coupler and the flight connection stub (in the upper flight section) into the lower flight section.

Step 3. Using the inspection hole as an access, bolt the flight connecting stub to the lower flight section using two 1/2" x 3-1/2" long (grade 8) black hex head capscrews and side depress locknuts.

Step 4. Slide the connecting band so it is spaced about half way on each auger housing. Tighten the connecting band in place, using six 3/8" x 1-1/2" long (grade 5) hex head capscrews and nuts.

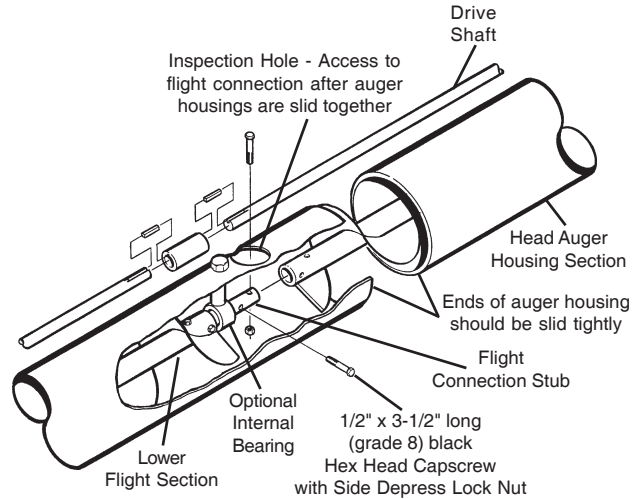

FIG. 5

NOTE: The connecting band was not shown in the drawing so the flight connection would be easier to see.

BAND-ON TRACK TO AUGER HOUSING - 57', 61' & 65' ONLY

A band-on track is used on 57', 61' and 65' models.

Step 1. Fasten the two connecting plates to the inside of the lower end of the track welded to the upper auger housing, using two 3/8" x 1-1/4" long grade 5 hex head capscrews, flat washers, lockwashers and nuts per each connecting plate. **IMPORTANT:** The connecting plates must be assembled to the inside of the track.

Step 2. Position the band-on track under the lower auger housing section (with the holes in the track positioned toward the upper auger section.)

Step 3. Fasten the two connecting plates to the band-on track using two 3/8" x 1-1/4" grade 5 hex head capscrews, flat washers, lockwashers and nuts per each connecting plate. Using the slots in the connecting plate, slide the ends of the track together so they are touching.

Step 4. Using 4" wide halfbands, secure the band-on track to the lower auger housing. Use four 5/16" x 1-1/2" long (Grade 5) hex head capscrews and nuts per each 4" wide halfband. On 57' & 61' Models, use two 4" wide halfbands. On 65' Models, use three 4" wide halfbands with a truss mount welded to the center halfband.

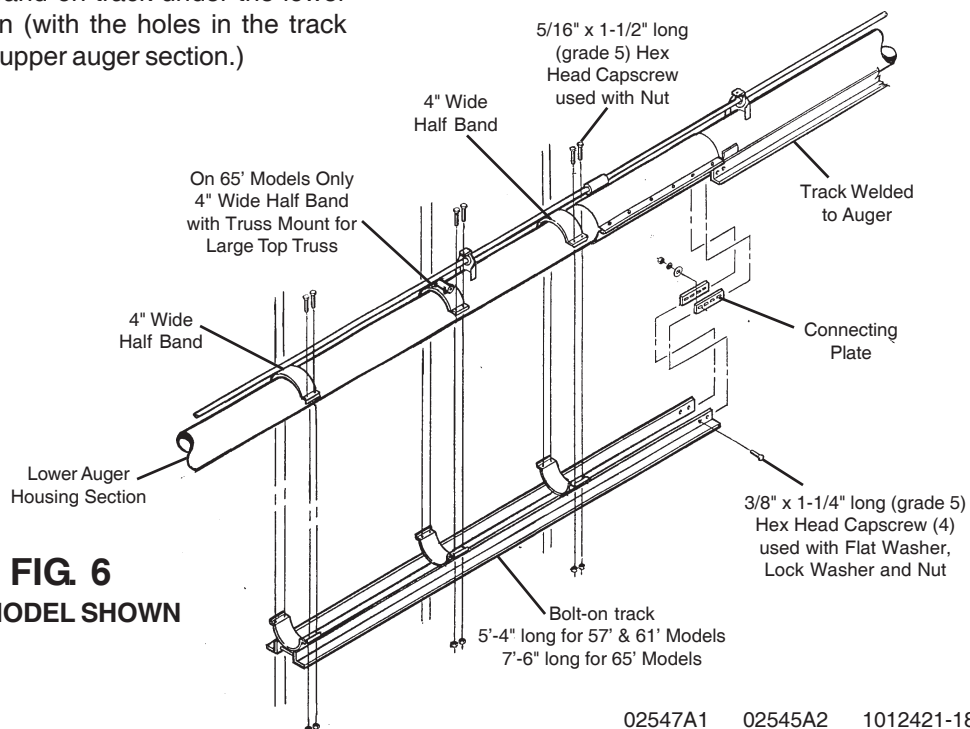

FIG. 6
65' MODEL SHOWN

ENCLOSED DRIVE LUBRICATIONS

The enclosed drive is located at the discharge end of the auger housing and is shipped **without oil**. **Oil is to be added to the unit during field assembly of the auger.** Oil will dissipate under normal operating conditions, therefore the oil level should be checked regularly. **Add 4 pints** of 90 EP (non-foaming) oil until the level of the oil reaches the check port.

DO NOT ADD MORE OIL THAN RECOMMENDED. ADDITIONAL OIL MAY DAMAGE THE SEALS OR BE FORCED OUT THROUGH THE VENTED PLUG.

For lubrication in normal operating temperature between 40° F to 120° F, we recommend the use of non-foaming, multi-purpose gear oil, SAE 90 weight. For temperatures below 40° F, use SAE 80 weight oil. Use grade commercially available for automotive differentials. Extra pressure additives may be of value in severe applications.

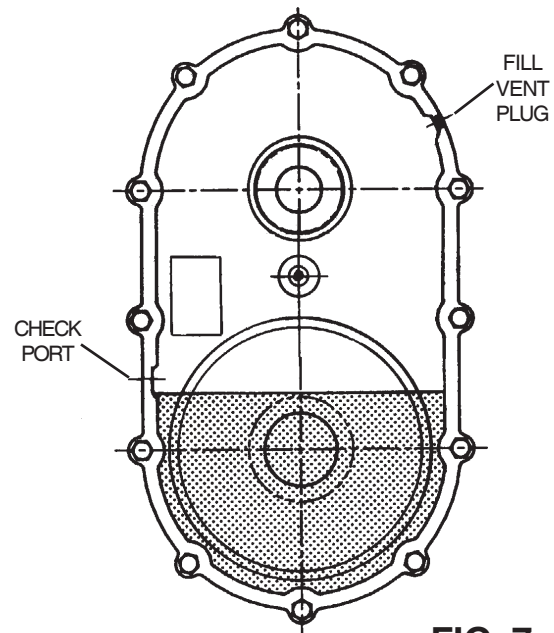

FIG. 7

INTAKE GUARD TO AUGER HOUSING

Install intake guard at intake end of auger housing. As you slide the assembly over the flighting and the auger housing, guide the intake stub shaft through the bearing. Clamp the intake guard to the auger housing with the top upper half band above stop, welded to the auger housing. See Fig. 8. Use eight 3/8" x 1-1/4" long (grade 5) hex head capscrews and nuts to clamp intake guard in place.

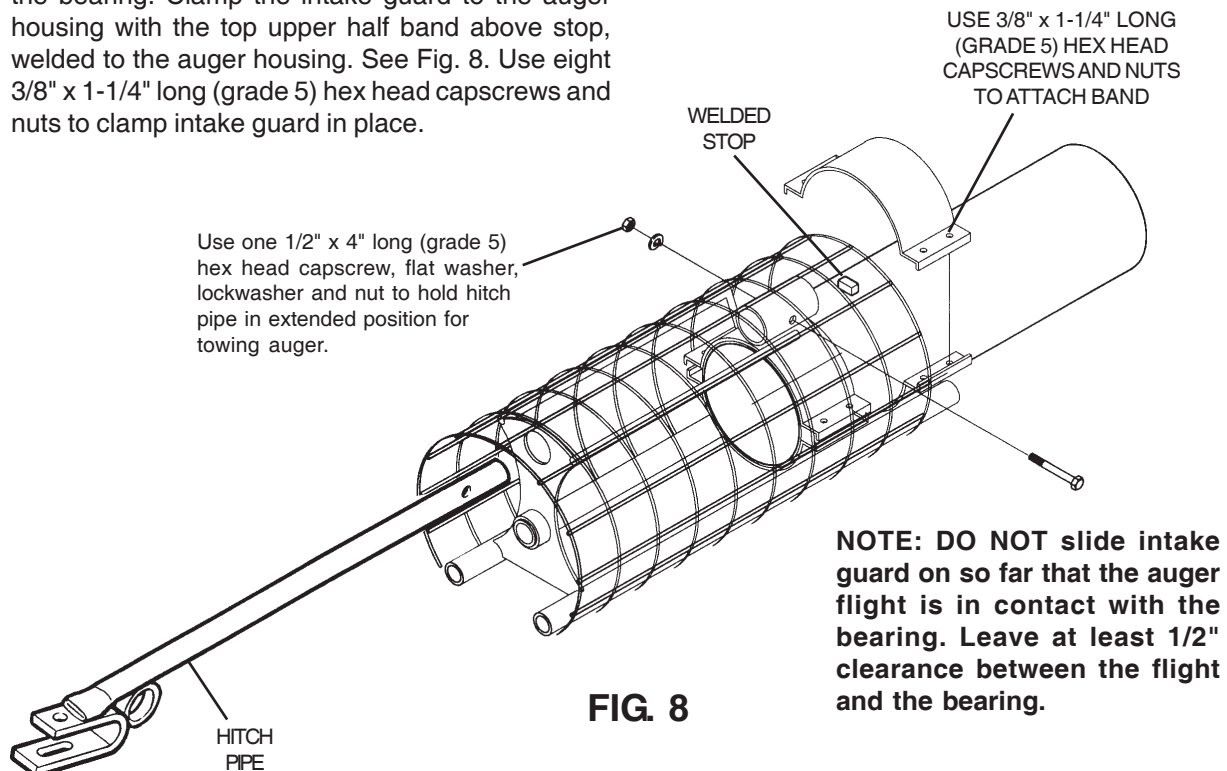

FIG. 8

ASSEMBLY INSTRUCTIONS

NOTICE - The assembly instructions on this page and page 21 and 22 are for PTO Driven Augers ONLY.

DRIVE SHAFT EXTENSION FOR PTO DRIVEN AUGER

Step 1. Bolt bearings to band-on bearing stands. (On 51' models, bolt bearings to the welded bearing stand on the lower tube section.) Attach each bearing using two retainers and one drive shaft cover mounting bracket. (See Fig. 9)

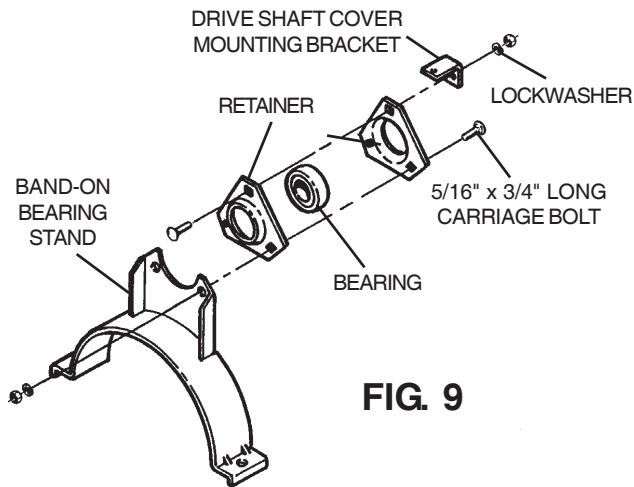

FIG. 9

GEARBOX ASSEMBLY

Step 1. Add oil to Gearbox. Gearboxes are equipped with two oil fill plugs and are shipped without oil. One plug is vented and must always be on the top side of the box.

IMPORTANT: ADD 90 EP (non-foaming) oil until the gearbox is half full.

Step 2. Attach gearbox to band-on mount with four 3/8" x 3/4" long (grade 5) hex head capscrews and lockwashers.

Step 3. Set gearbox on auger and connect to drive shaft with coupler and two 1/4" x 1-1/2" long square keys. (See Fig. 11)

Step 4. Secure gearbox mount to auger housing using half band (with a manual container bracket) and four 3/8" x 1-1/4" long (grade 5) hex head capscrews and locknuts.

Step 5. Attach the drive shaft cover bracket to top of gearbox with two 3/8" x 3/4" long (grade 5) hex head capscrews with lockwashers.

DRIVE SHAFT COVERS

The covers should be placed on the auger while it is lying on the ground before it is placed on the undercarriage. **PLEASE REMEMBER THESE COVERS PROVIDE IMPORTANT PROTECTION FOR PERSONS AROUND AN AUGER THAT IS IN OPERATION.** Proper installation is important.

Step 2. Slide bearing stands onto extension drive shaft. Attach extension drive shaft to auger drive shaft using a coupler and two 1/4" x 1-1/2" square keys. See Fig. 12 on page 21 for correct band-on bearing stand spacing. Fasten band-on bearing stand in place, using half bands and two 5/16" x 1-1/2" (grade 5) hex head capscrews and nuts. Tighten two bearing setscrews to lock bearing to extension drive shaft.

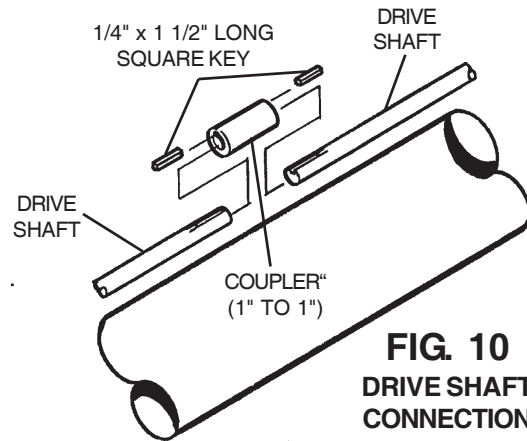

**FIG. 10
DRIVE SHAFT
CONNECTION**

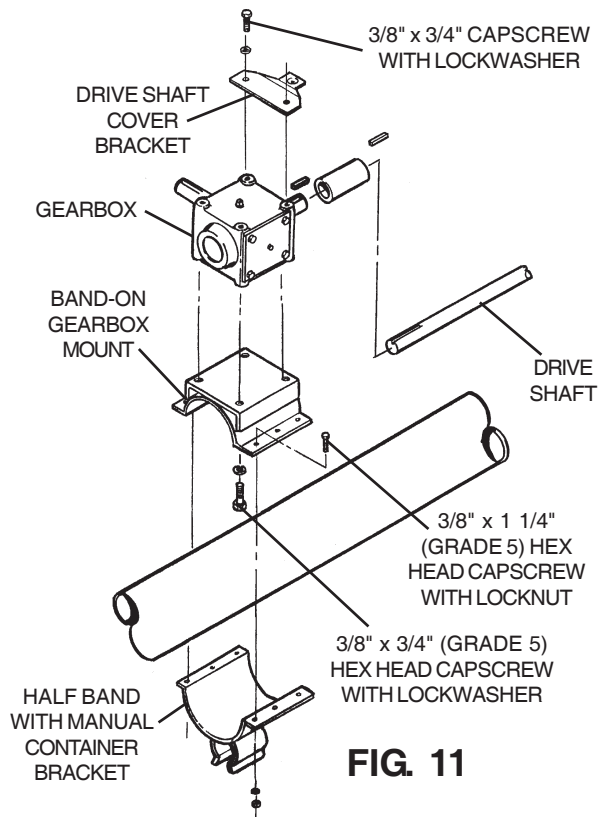

FIG. 11

Determine the location of the various lengths of drive shaft covers by placing them alongside the tube assembly in the order shown in Fig. 13 on page 22. Begin at the intake end of unit. Work up the unit, overlapping covers at each bearing stand. See page 23 for proper assembly of the drive shaft covers.

NOTICE: The assembly instructions on this page and pages 20 and 22 are for PTO Driven Augers Only.

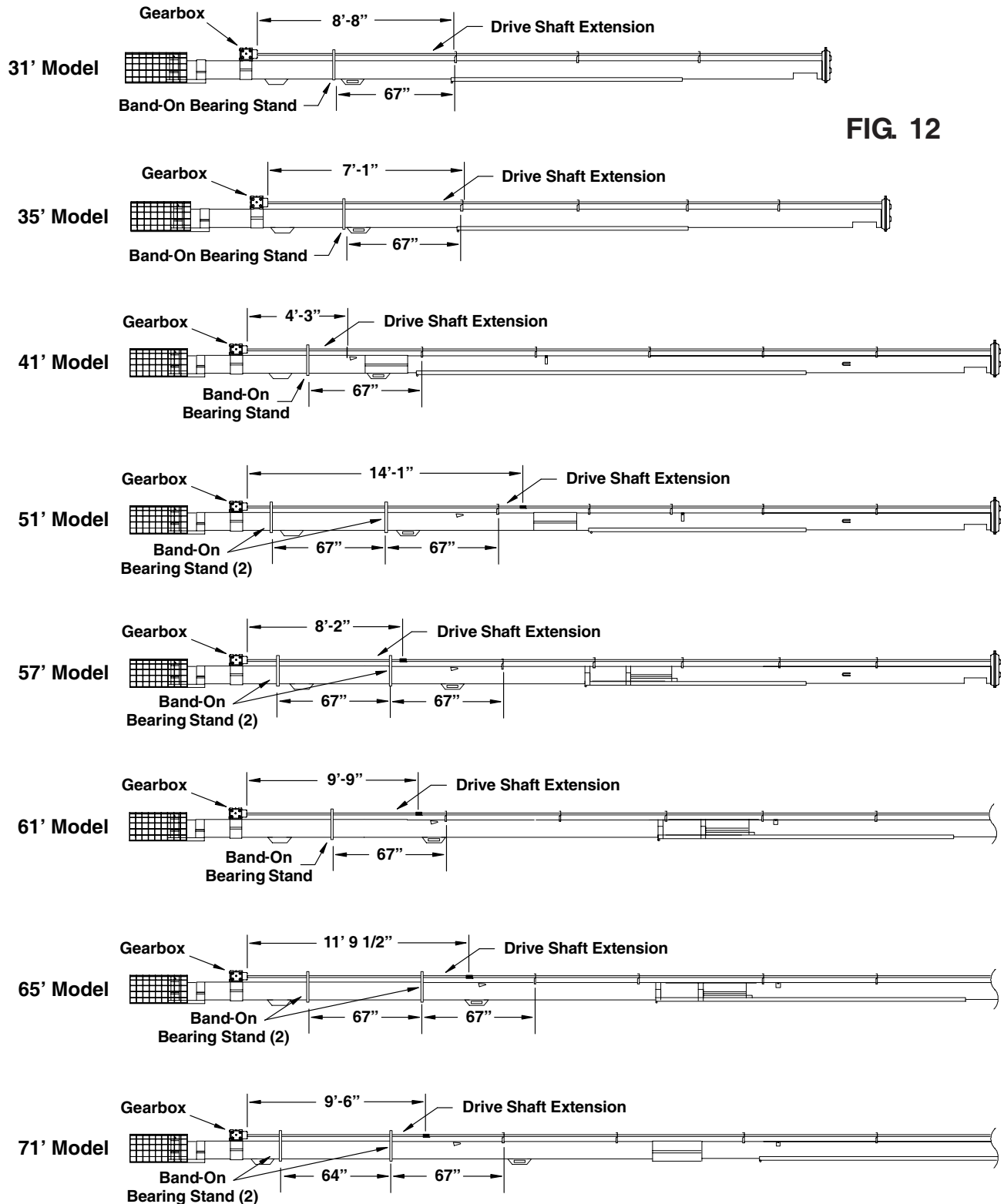

FIG. 12

ASSEMBLY INSTRUCTIONS

NOTICE: The assembly instructions on this page and pages 20 and 21 are for PTO Driven Augers Only.

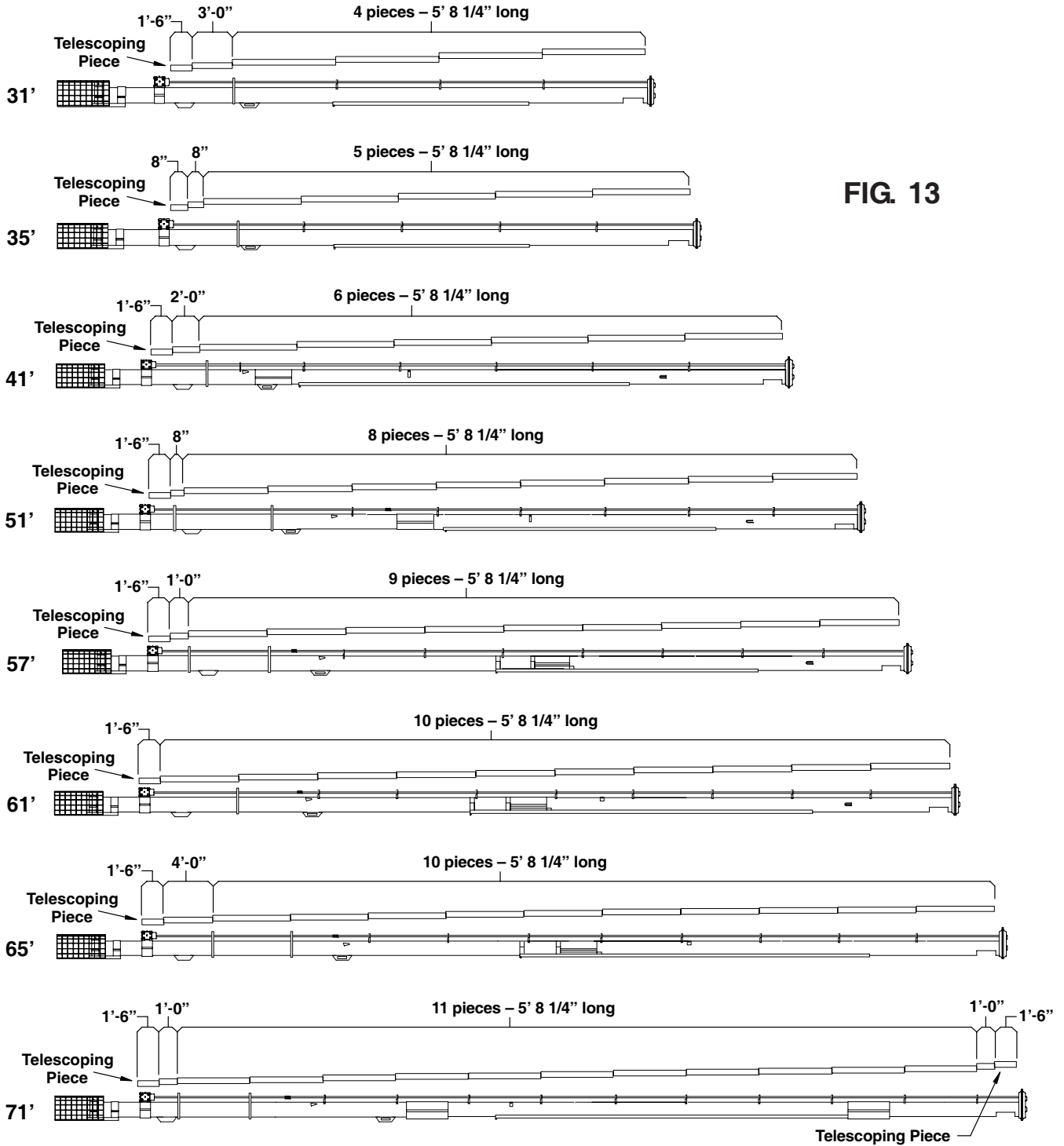

FIG. 13

DRIVE SHAFT COVERS

TO INSTALL TWO-PIECE DRIVE SHAFT COVER

There is a special two piece section of drive shaft cover that installs between the gearbox and the first bearing stand. It telescopes together to vary in length.

This telescoping cover consists of a standard piece that telescopes into a special piece of cover with retaining bottom edges.

Center the slots in the covers over the hole in the mounting bracket.

Place 1" O.D. flat washer over the slot in the cover and drive the self tapping slotted hex head screw through the hole in the mounting bracket. Tighten the metal screw down to the flat washer and cover. **DO NOT** over tighten and strip out the hole in the mounting bracket. See Fig. 14.

CAUTION: THE TWO PIECE TELESCOPING COVER SHOULD OVERLAP AT LEAST 6" FOR PROPER INSTALLATION.

TO INSTALL ONE-PIECE DRIVE SHAFT COVER

Center the slots in the covers over the hole in the mounting bracket. Place 1" O.D. flat washer over the slot in the cover, and drive the self tapping slotted hex head screw through the hole in the mounting bracket. Tighten the metal screw down to the flat washer and metal cover. **DO NOT** over tighten and strip out the hole in the mounting bracket. See Fig. 14.

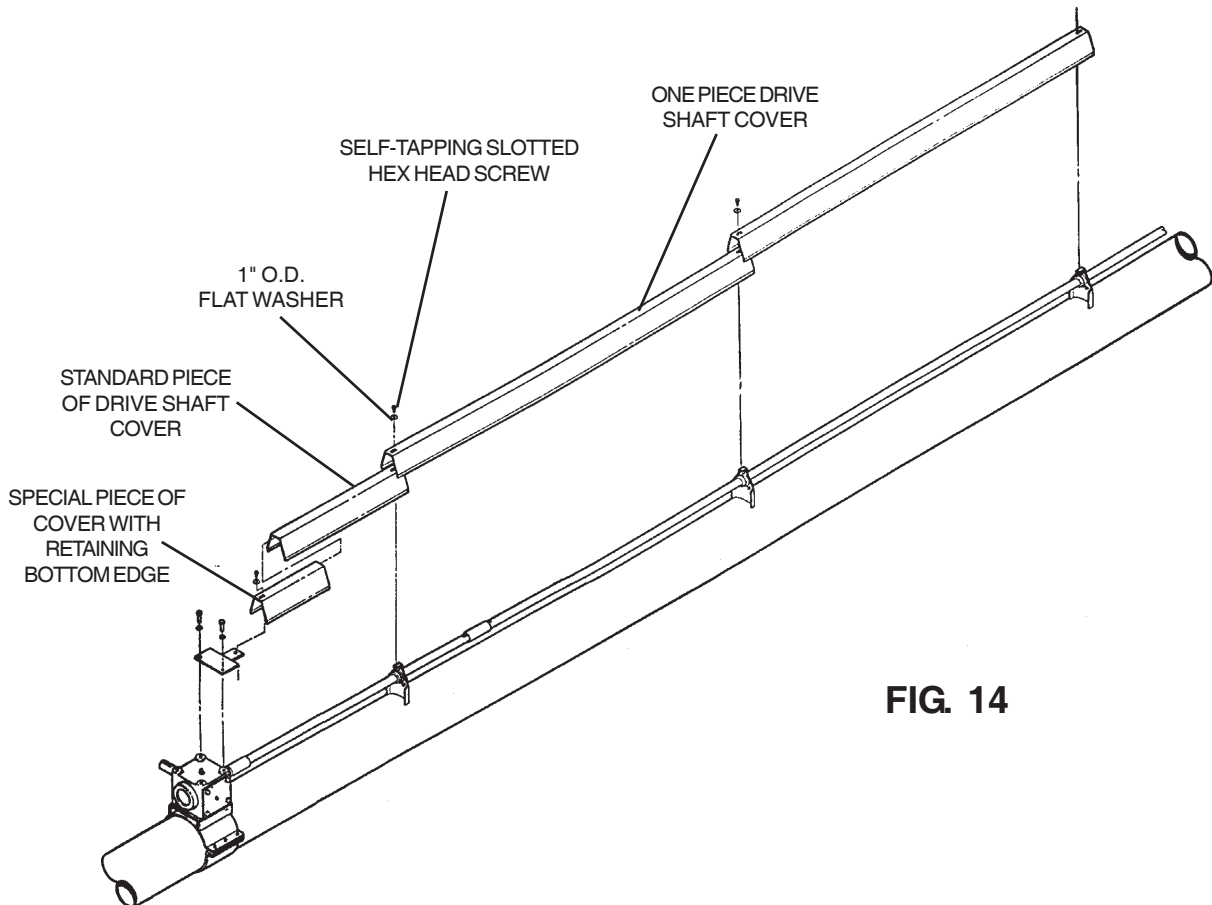

FIG. 14

ASSEMBLY INSTRUCTIONS

NOTICE - The assembly instructions on this page and page 25 are for (Top Mount) Electric Driven Augers ONLY.

DRIVE SHAFT EXTENSION FOR 51' ONLY

Step 1. Bolt bearings to weld-on bearing stand at the upper end of the lower auger section. (See Fig. 18 on page 25 for location.) Attach the bearing using two retainers and one drive shaft cover mounting bracket. (See Fig. 15.)

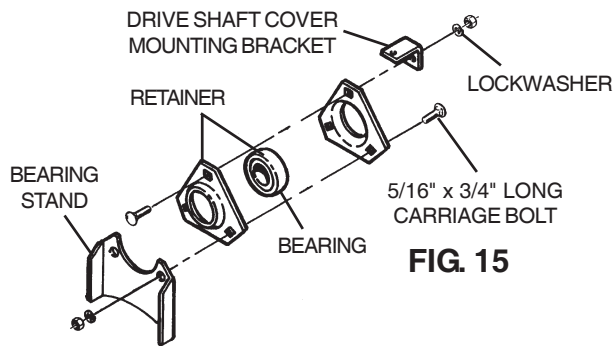
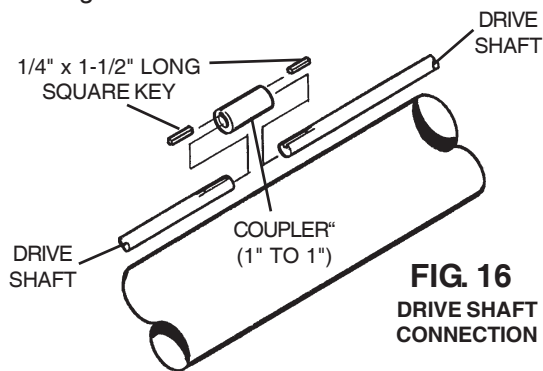

FIG. 15

Step 2. Slide 6'-7" long drive shaft through bearing stand. Attach 6'-7" long drive shaft to auger drive shaft using a coupler and two 1/4" x 1-1/2" square keys. Tighten two bearing setscrews to lock bearing to 6'-7" long drive shaft.



**FIG. 16
DRIVE SHAFT
CONNECTION**

DRIVE SHAFT COVERS

The covers should be placed on the auger while it is lying on the ground before it is placed on the undercarriage. **PLEASE REMEMBER THESE COVERS PROVIDE IMPORTANT PROTECTION FOR PERSONS AROUND AN AUGER THAT IS IN OPERATION.** Proper installation is important.

Determine the location of the various lengths of drive shaft covers by placing them alongside the tube assembly in the order shown in Fig. 18 on page 25. Begin at the intake end of the unit. Work up the unit, overlapping covers at each bearing stand. See page 23 for proper assembly of the drive shaft covers.

GEARBOX ASSEMBLY

Step 1. Add oil to gearbox. Gearboxes are equipped with two oil fill plugs and are shipped without oil. One plug is vented and must always be on the top side of the box.

IMPORTANT: ADD 90 EP (non-foaming) oil until the gearbox is half full.

Step 2. Attach gearbox to band-on mount with four 3/8" x 3/4" long (grade 5) hex head capscrews and lockwashers.

Step 3. Set gearbox on auger and connect to drive shaft with coupler and two 1/4" x 1-1/2" long square keys. (See Fig. 17.)

Secure gearbox mount to auger using half band (with a manual container bracket) and four 3/8" x 1-1/4" long (grade 5) hex head capscrews and locknuts.

Step 4. Attach the drive shaft cover bracket to top of gearbox with two 3/8" x 3/4" long (grade 5) hex head capscrews with lockwashers.

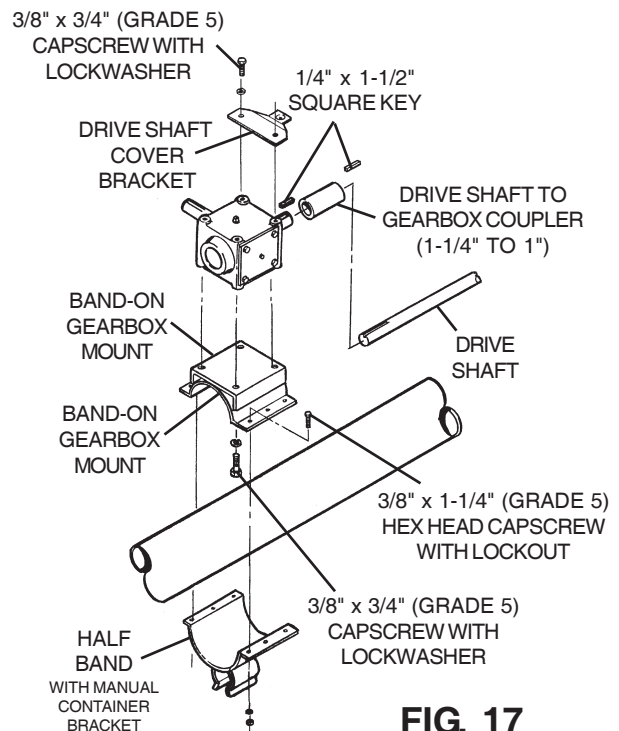

FIG. 17

NOTICE - The assembly instructions on this page and on page 24 for (Top Mount) Electric Driven Augers ONLY.

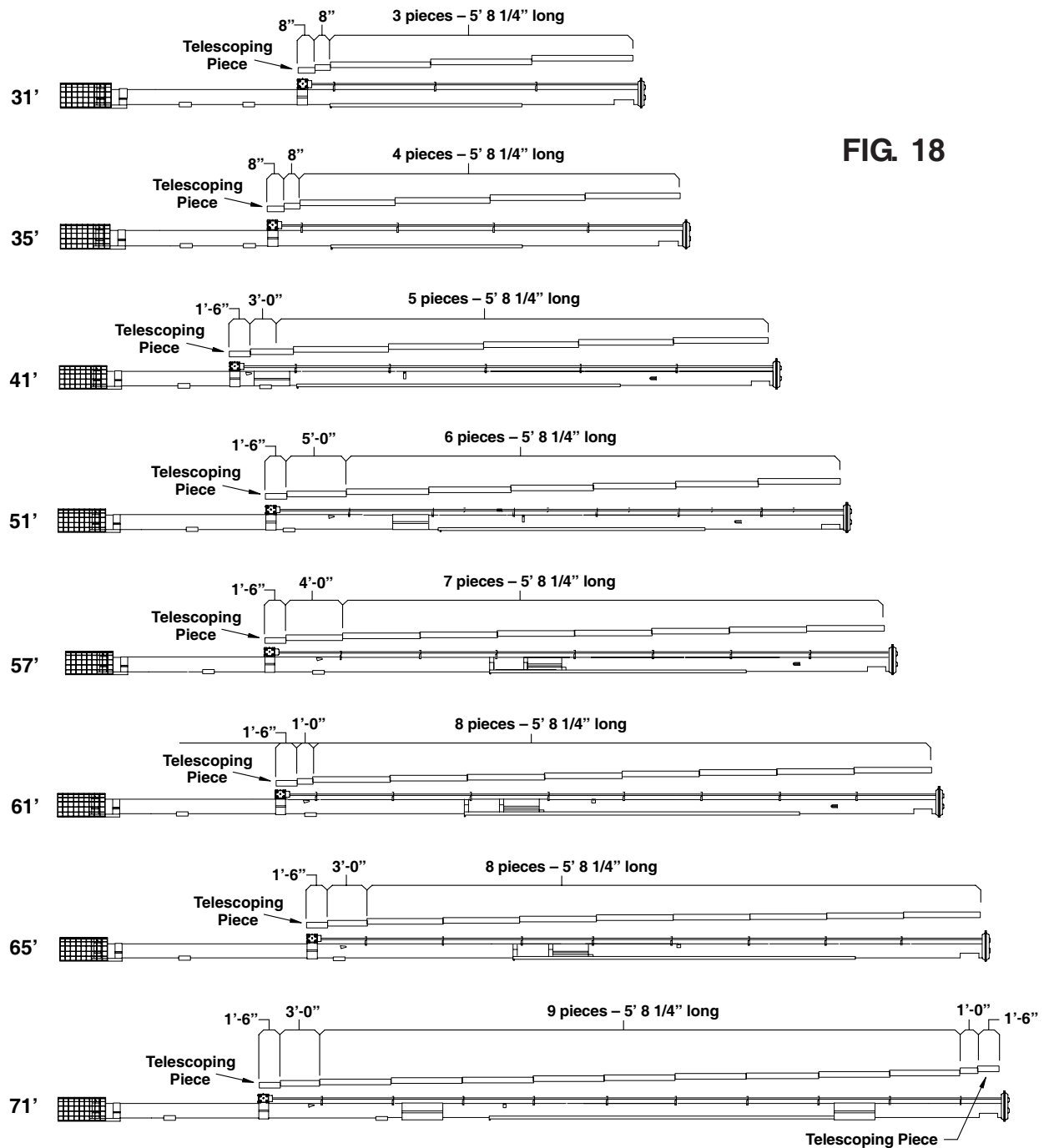

FIG. 18

ASSEMBLY INSTRUCTIONS

NOTICE - The assembly instructions below are for Auger Mounted Underslung Gas Engine Driven 31', 41' & 51' Augers ONLY.

GEARBOX ASSEMBLY (UNDERSLUNG)

Step 1. Add oil to gearbox. Gearboxes are equipped with two oil fill plugs and are shipped without oil. One plug is vented and must always be on the top side of the box.

IMPORTANT: ADD 36.9 oz. (1.09 L) of an 80W-90 EP (non-foaming) oil before operation.

Step 2. Attach gearbox to band-on mount with four 1/2" x 1" long (grade 5) hex head capscrews and lockwashers.

Step 3. Set gearbox on auger and connect to drive shaft with coupler and two 1/4" x 1-1/2" long square keys. (See Fig. 19.)

Step 4. Secure gearbox mount to auger using halfband and four 3/8" x 1-1/2" long (grade 5) hex head capscrews and locknuts.

Step 5. Attach the drive shaft cover bracket to top of gearbox with two 1/2" x 3/4" long (grade 5) hex head capscrews with lockwashers.

Step 6. Using a plain (6" wide) halfband, fasten the halfband with manual container bracket to the auger housing 45" from the intake end of the auger tube. Use six 3/8" x 1-1/4" long (grade 5) hex head capscrews with locknuts. See Fig. 19.

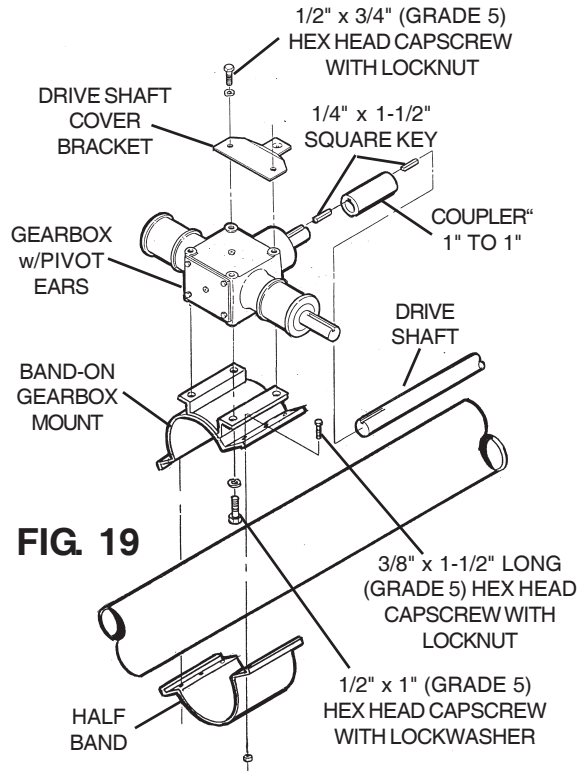
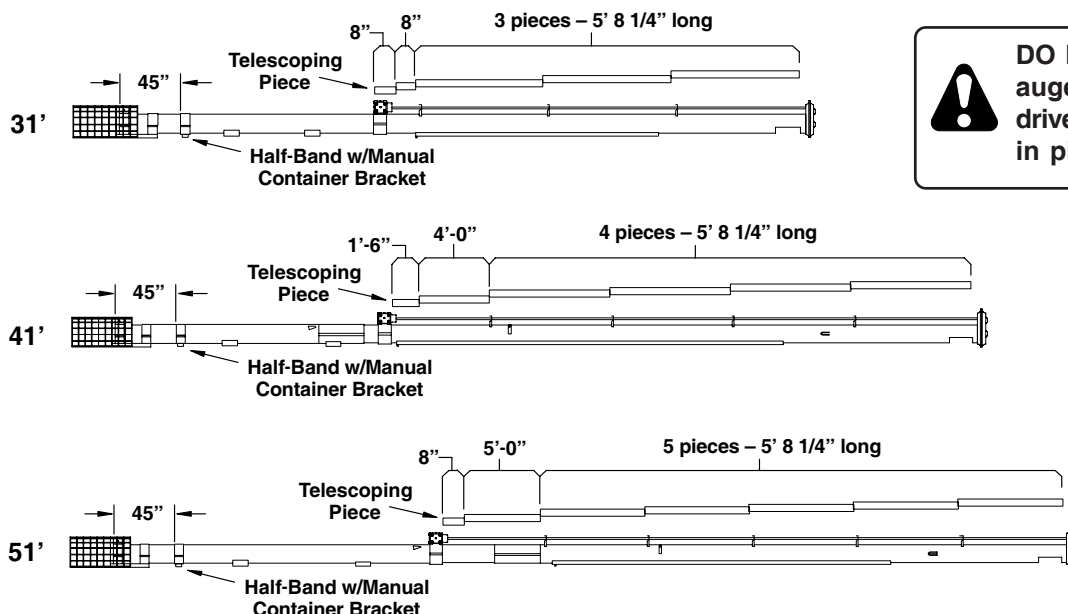

FIG. 19

DRIVE SHAFT COVERS (UNDERSLUNG)

The covers should be placed on the auger while it is lying on the ground before it is placed on the undercarriage. **PLEASE REMEMBER THESE COVERS PROVIDE IMPORTANT PROTECTION FOR PERSONS AROUND AN AUGER THAT IS IN OPERATION.** Proper installation is important.

Determine the location of the various lengths of drive shaft covers by placing them alongside the tube assembly in the order shown in Fig. 20 below. Begin at the intake end of unit. Work up the unit, overlapping covers at each bearing stand. See page 23 for proper assembly of the drive shaft covers.



DO NOT operate auger without all drive shaft covers in place.

FIG. 20

(NOTE: Top Truss is not required on 31' Model.)

TOP TRUSS - 41' & 51' AUGER

Step 1. To assemble the bolt-together type truss, attach the two vertical truss tubes to the truss mounts on the auger housing, using 5/8" x 1-1/2" long (grade 5) hex head capscrews, lockwashers and nuts. (See Fig 22.) To locate the truss mounts on the auger housing, measure from the discharge end of the tube. It should be 22'-10" back on the tube for 41' & 51' models.

Step 2. Attach the truss top crossmember (24" long) to the vertical tubes, using 5/8" x 1-1/2" long (grade 5) hex head capscrews, lockwashers and nuts. **DO NOT** tighten at this time.

IMPORTANT: Be sure to slide the hex head capscrews through the cable clamp clips before putting hex head capscrews through the horizontal tube. The hex head capscrews must go through the horizontal tube from the top.

Step 3. Attach cables to upper cable anchors at discharge end, using two cable clamps per each cable. On 41' Models, use 26' long cables. On 51' Models, use 31' long cables. NOTE: Secure the clamp u-bolts against the loose end of the cable.

Step 4. Run the cables over the center truss and attach, using cable clips. **DO NOT** tighten cable clips down at this time.

Step 5. Install eye bolts through anchors at intake end, using flat washer and two nuts per each eyebolt. (See Fig. 23.)

Step 6. Attach cables to eye bolts, using two cable clamps per cable. NOTE: Secure the clamp u-bolts against the loose end of the cable. (See Fig. 23.)

Step 7. Using eye bolts, tighten cable to remove slack to where the cable is reasonably snug. Tighten both cables the same. **DO NOT** over tighten. Some adjustment can be made after the auger is completely set up.

Step 8. Adjust the truss support to where it is 90° to the tube. Tighten cable clips on top of truss to secure cable in place. Tighten the 5/8" x 1-1/2" long hex head capscrews mounting truss assembly to auger housing.

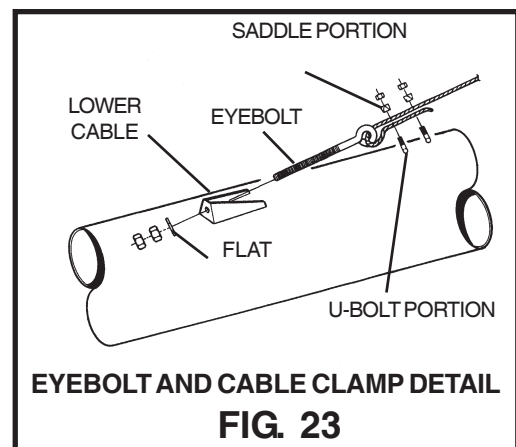
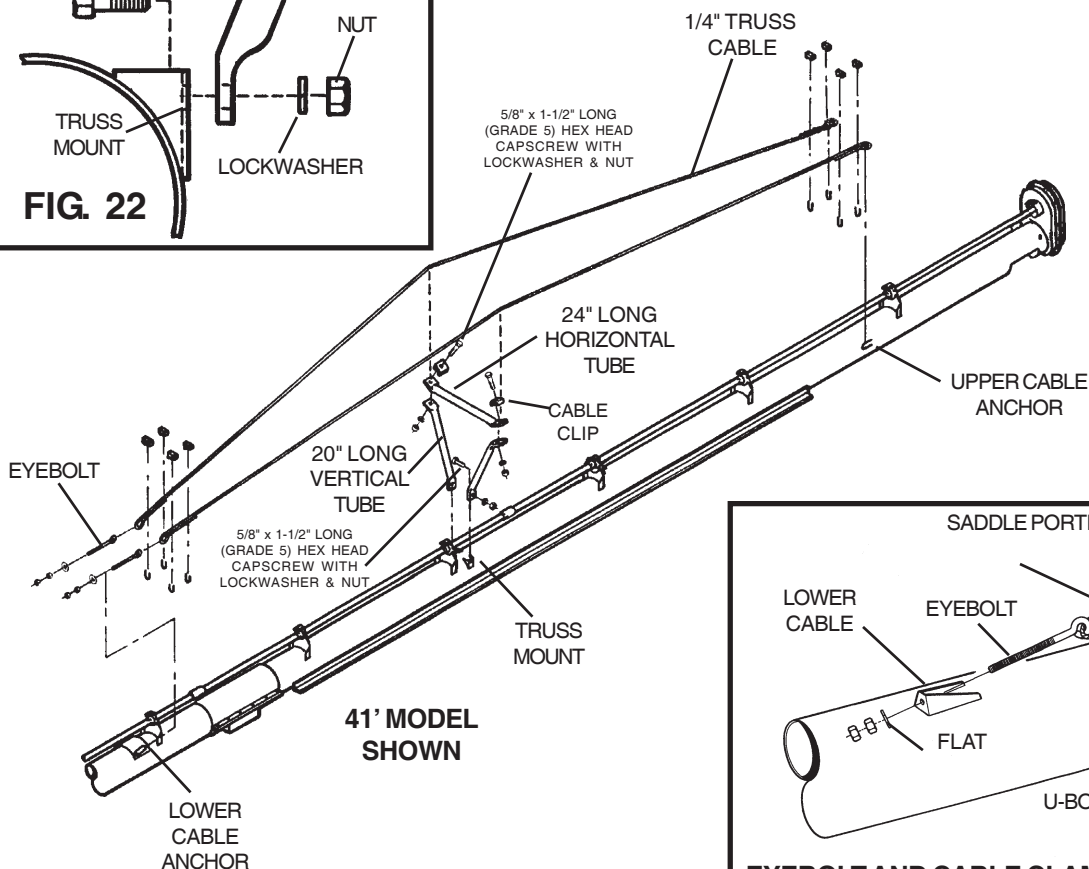
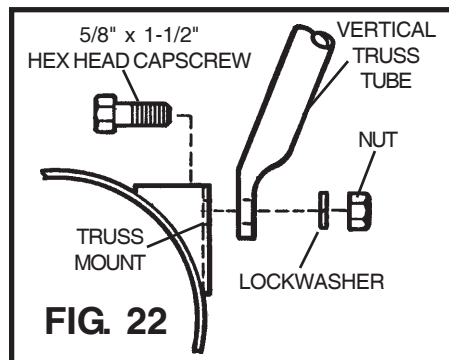

ASSEMBLY INSTRUCTIONS

TOP TRUSS FOR 57' & 61'

Step 1. Attach the center truss to the auger housing using the 3/4" x 10-1/2" attachment pin and cotter pins provided with the center truss. To locate the truss mount on the auger housing, measure from the head end of the auger housing (discharge end). It should be 22'-6" back on 57' & 61' models.

Step 2. Attach cables to the upper cable anchors at the discharge end, using two cable clamps per each cable. NOTE: Secure the clamps u-bolt against the loose end of the cable. See Fig. 25.

Step 3. Run the cables over the center truss and attach, using a cable clamp to secure cable to the top of the truss. **DO NOT** tighten these cable clamps at this time.

Step 4. Install eye bolts through anchors at intake end, using flat washer and two nuts per each eyebolt. See Fig. 25.

Step 5. Attach cables to eye bolts, using two cable clamps per each cable. NOTE: Secure the clamp u-bolt against the loose end of the cable. See Fig. 25.

Step 6. Using eye bolts, tighten cable to remove slack to where the cable is reasonably snug. Tighten both cables the same. **DO NOT** over tighten. Some adjustments can be made after the auger is completely set-up.

Step 7. Adjust the truss support to where it is 90° to the tube. Tighten cable clamps on top of the truss.

| 61' MODEL SHOWN (57' SIMILAR) | |
|----------------------------------|--------------|
| UNIT SIZE | CABLE LENGTH |
| 57' MODELS | 36'-0" |
| 61' MODELS | 40'-0" |

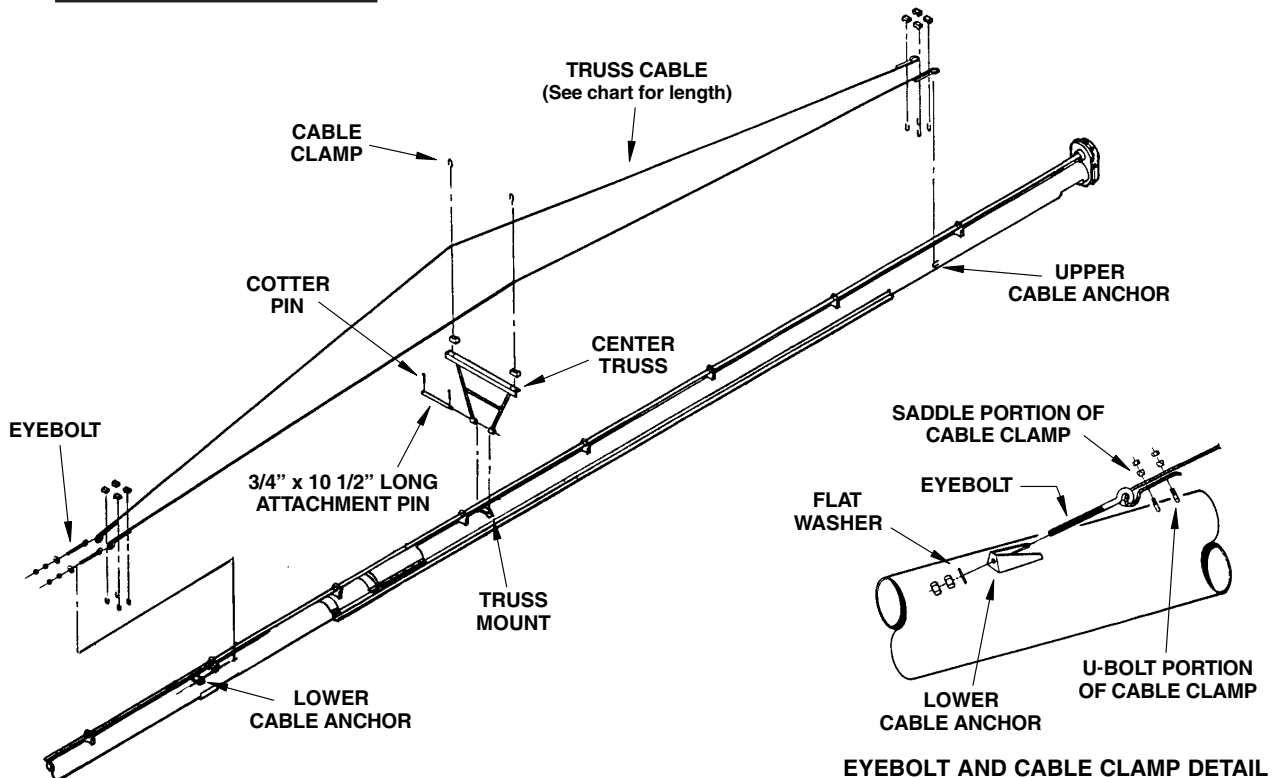

FIG. 24

FIG. 25

TOP TRUSS FOR 65' MODEL

Step 1. Attach the larger truss to the truss mount that is welded to the halfband, (that secures the band-on track to the lower auger section.) Use a 3/4" x 14-1/4" long attachment pin and cotter pins provided with the large truss to secure the truss to halfband.

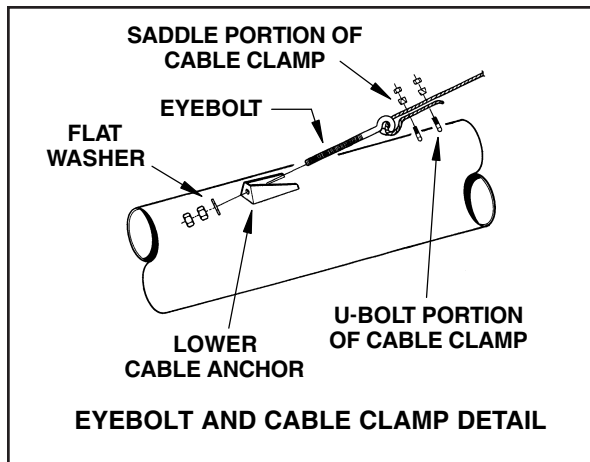

FIG. 27

Step 2. Attach the smaller truss to the truss mount welded on the upper auger section, using the 3/4" x 10-1/2" attachment pin and cotter pins provided with the smaller truss. To locate the truss mount on the auger housing, measure from the head end of the auger housing (discharge end). It should be 26'-6" back on 65' models.

Step 3. Attach cables to the upper cable anchors at the discharge end using two cable clamps per each cable.

NOTE: Secure the clamps u-bolt against the loose end of the cable.

Step 4. Run the cable over the short truss then over the large truss and down towards the lower anchors.

Step 5. Use cable clamps to secure the cable to the top of the trusses. **DO NOT** tighten cable clamps at this time.

Step 6. Install eyebolts through anchors at intake end, using flat washer and two nuts per eyebolt. See Fig. 27.

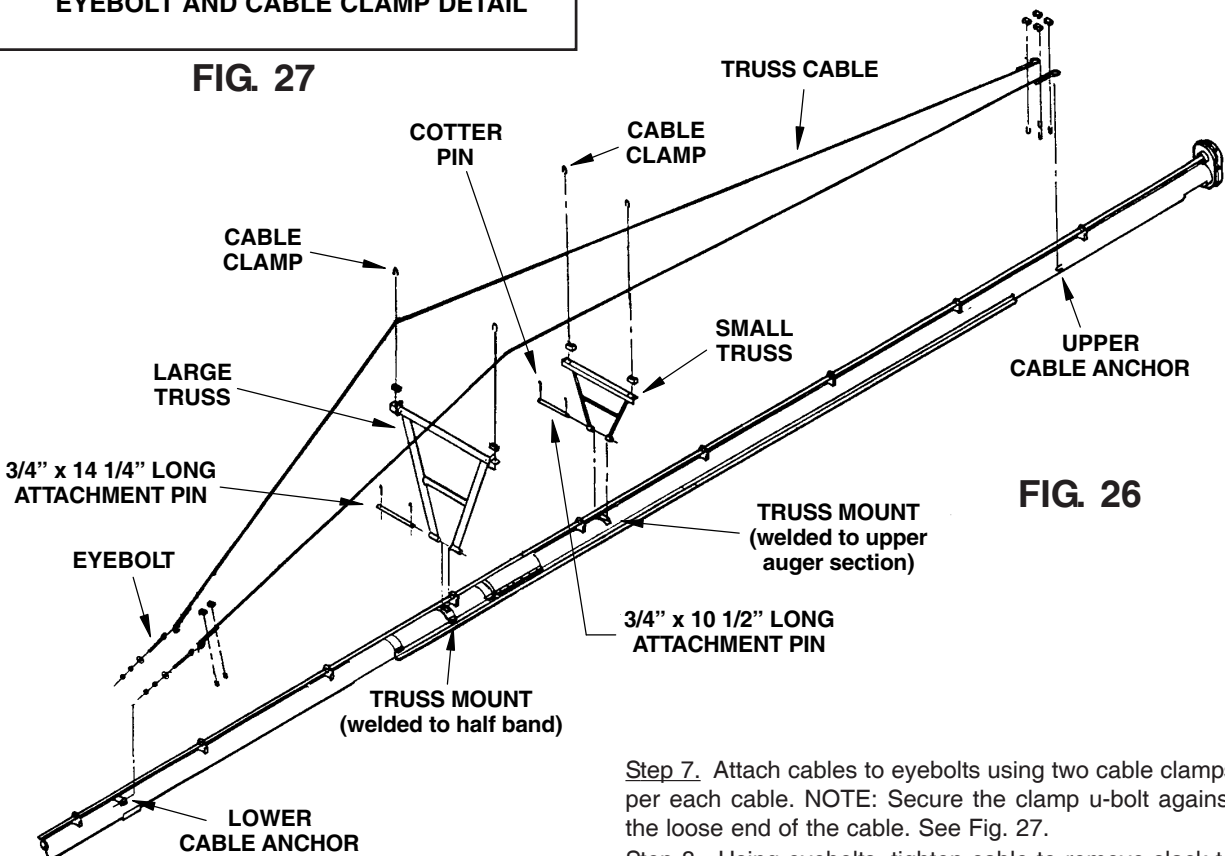

FIG. 26

Step 7. Attach cables to eyebolts using two cable clamps per each cable. NOTE: Secure the clamp u-bolt against the loose end of the cable. See Fig. 27.

Step 8. Using eyebolts, tighten cable to remove slack to where the cable is reasonably snug. Tighten both cables the same. **DO NOT** over tighten. Some adjustments can be made after the auger is completely set up.

Step 9. Adjust the truss support to where it is 90° to the tube. Tighten cable clamps on top of the truss, that were left loose in Step 5.

ASSEMBLY INSTRUCTIONS

TOP TRUSS FOR 71' MODEL

Step 1. Attach the center truss support to the top of the middle auger housing near the connecting band. Use the 3/4" x 14-1/4" long attachment pin and cotter pins provided for attaching the support to the auger housing.

Step 2. Attach two 5/16" x 17'-6" long cables to the center truss support using cable thimbles and two cable clamps per cable. (See Fig. 30.)

NOTE: Secure the clamps u-bolts against the loose end of the cable.

Step 10. Run the cables over the upper truss (located ahead of the connecting band of the head section). Attach using two cable clamps per cable. **NOTE:** Secure the clamp u-bolt against the loose end of the cable.

Step 11. Using eyebolts, tighten cable to remove slack to where each cable is reasonably snug. Tighten both cables the same. **DO NOT** over tighten.

Step 12. Some adjustment can be made after the auger is completely set up. Adjust both the truss support to where they are 90° and square to the auger housing. Tighten cable clamps to the top of the upper truss.

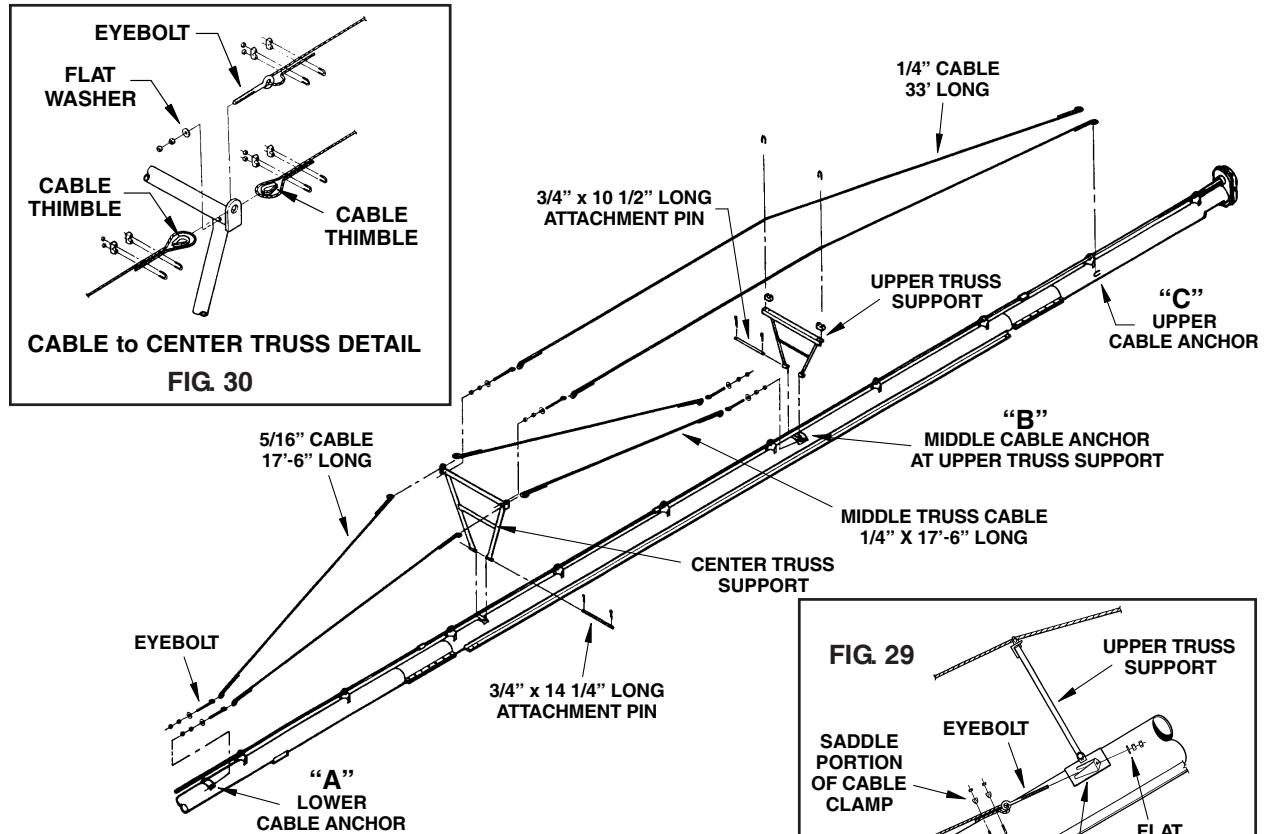

Step 3. Attach these cables to the lower cable anchor (A) using 1/2" x 8" long eyebolts. (See Fig. 31.)

Step 4. Use flat washers and two nuts to secure the eyebolts to the lower cable anchor. **DO NOT** tighten these cables.

Step 5. Attach the two 1/4" x 17'-6" long middle truss cables to the center truss support, using a cable thimble and two cable clamps per cable (See Fig. 30.) **NOTE:** Secure the clamp u-bolt against the loose ends of the cable.

Step 6. Attach these cables to the upper cable anchors (B) (located at the upper truss support mount), using 1/2" x 8" long eyebolts. (See Fig. 29.)

Step 7. Use flat washers and two nuts to secure the eyebolts to the anchors.

Step 8. Secure upper truss support to the top of the middle auger housing, 22'-4" from the head end of the tube at the discharge end. Use the 3/4" x 10-1/2" long attachment pin and cotter pins provided for attaching the support to the auger housing.

Step 9. Attach two 1/2" x 8" eyebolts to the center truss support using flat washers and two nuts per eyebolt. See Fig. 30. Fasten the 1/4" x 33' cables to the eyebolts, using a cable thimble and two cable clamps per cable. **NOTE:** Secure the clamp u-bolt against the loose end of the cable.

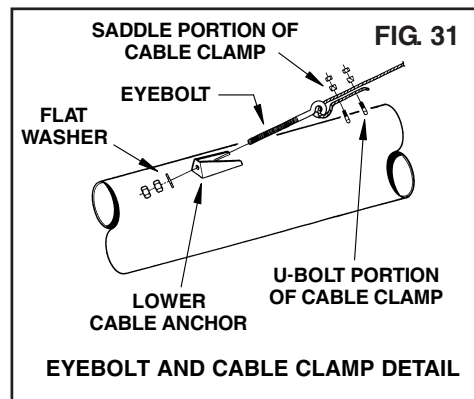
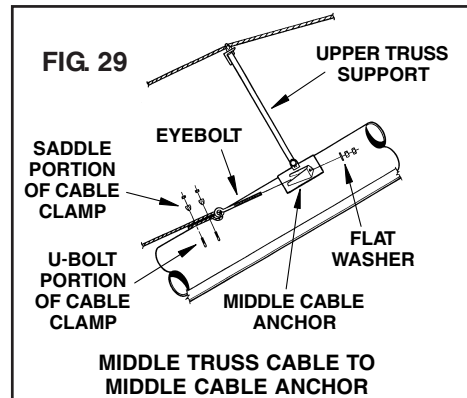
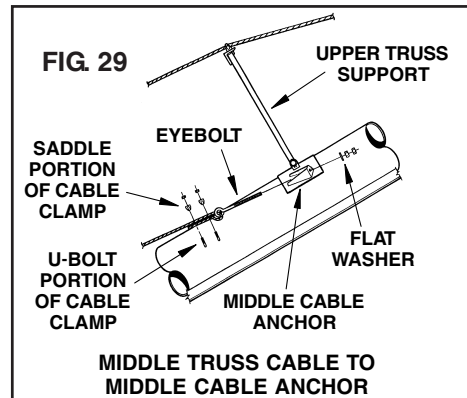

HUB AND SPINDLE TO UNDERCARRIAGE ASSEMBLY

The hubs, bearings, seals and spindles are assembled at the factory and are pressure packed with grease at that time.

Slide the hub and spindle assembly into the undercarriage axle and secure with 1/2" (grade 5) hex head capscrew and nylon locknut. See Fig 32.

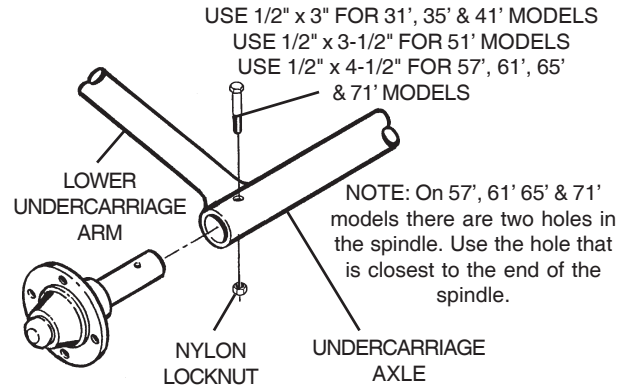

**HUB AND SPINDLE ASSEMBLY
FIG. 32**

UNDERCARRIAGE SLIDE TO TRACK ASSEMBLY

Lift the auger assembly a few feet by lifting at a point near the center of the auger with a chain hoist or other safe, suitable means. **DO NOT** lift the entire weight of the auger from the extreme end. **DO NOT** use drive shaft to lift auger. Use a sling completely around auger housing assembly for lifting. Install the undercarriage slide onto the track from the discharge end. Be sure the undercarriage is installed on the track in a manner whereby it cannot be removed from the track after the stop has been installed. See Fig. 33.

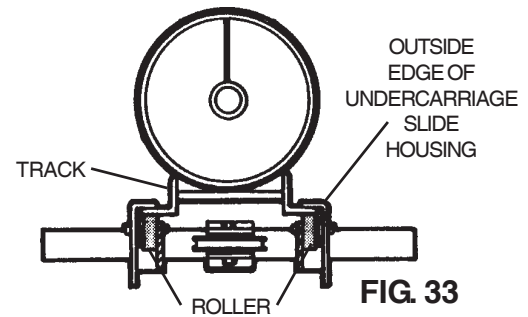

UNDERCARRIAGE STOP TO TRACK ASSEMBLY

A stop must be bolted on the discharge end of the undercarriage track on all lengths of augers. Use two 1/2" x 1-1/2" long (grade 5) hex head capscrews, lock washers and nuts to secure the stop to the track angle.

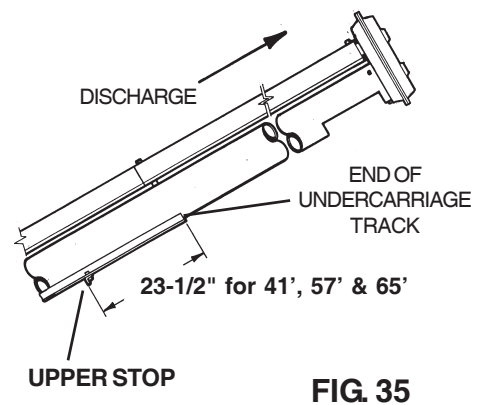
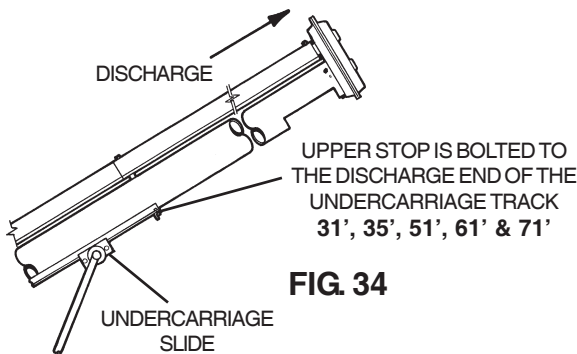

FIG. 35

UNDERCARRIAGE SLIDE STOP ASSEMBLY FOR 41' ONLY

On the 41' models only, a stop **MUST** be bolted on the intake end of the undercarriage track, 37-3/4" from the end. Use two 1/2" x 1-1/2" long (grade 5) hex head capscrews, lockwashers and nuts. See Fig. 36.

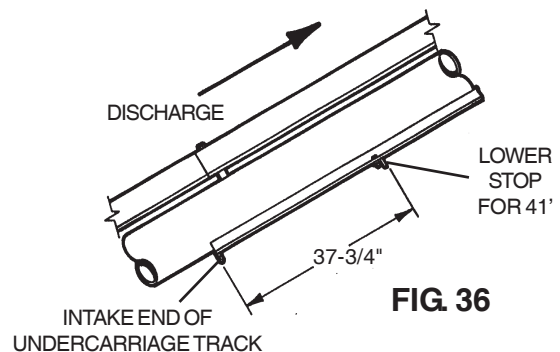

FIG. 36

ASSEMBLY INSTRUCTIONS

LOWER UNDERCARRIAGE ARMS TO AUGER HOUSING ASSEMBLY for 31', 35', 41', 51', 57', 61' & 65' MODELS

| Model Size | "A" |
|------------|-----------------------|
| 31' | 8'-2" (98") |
| 35' | 7'-6" (90") |
| 41' | 9'-2" * (110") |
| 51' | 11'-10" (142") |
| 57' | 14'-3 1/2" (171 1/2") |
| 61' | 14'-6" (174") |
| 65' | 16'-3" (195") |

*9'-6" for units with Internal Bearings

Lift the auger tube assembly high enough to attach the lower arm of undercarriage to auger housing assembly. Keep undercarriage slide against the upper undercarriage stop by securing temporarily with chain. Bolt the lower arm of the undercarriage to mount welded on lower auger housing, using four 1/2" x 1-1/4" long (grade 5) hex head capscrews and nylon locknuts. See Fig. 37.

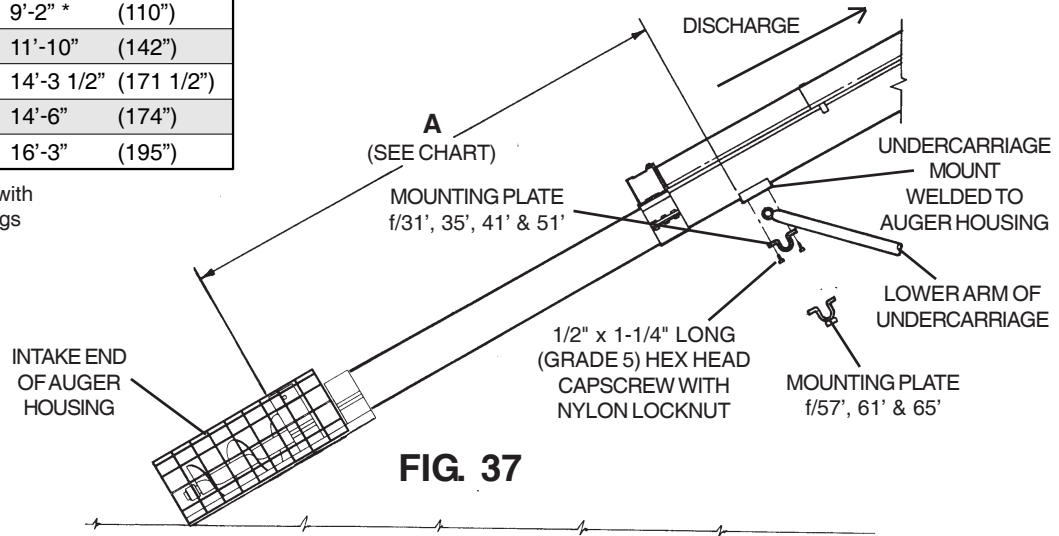

FIG. 37

IMPORTANT - On 57', 61' & 65' MODELS

Continue to support the auger with the lifting means after the undercarriage has been attached and until the bottom truss is completely installed and the truss cable is tightened. See Bottom Truss Assembly Instructions on page 33.

FOR 10" x 71' MODEL ONLY

Lift the auger housing assembly high enough to attach the lower arm of undercarriage to auger housing assembly. Keep undercarriage slide against the upper undercarriage stop by securing temporarily with chain. Attach lower arm of undercarriage to auger housing assembly, using four 5/8" x 1-1/2" long (grade 5) hex head capscrews and nylon locknuts. See Fig. 38.

IMPORTANT: Continue to support the auger with the lifting means after the undercarriage has been attached until the bottom truss is completely installed and truss cable is tightened. See Bottom Truss Assembly Instructions on page 33.

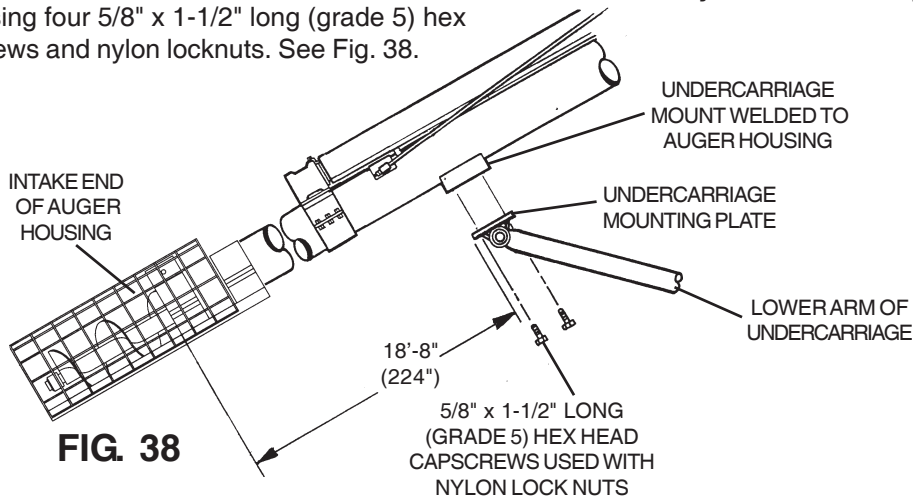

FIG. 38

BOTTOM TRUSS FOR 57', 61', 65' & 71'

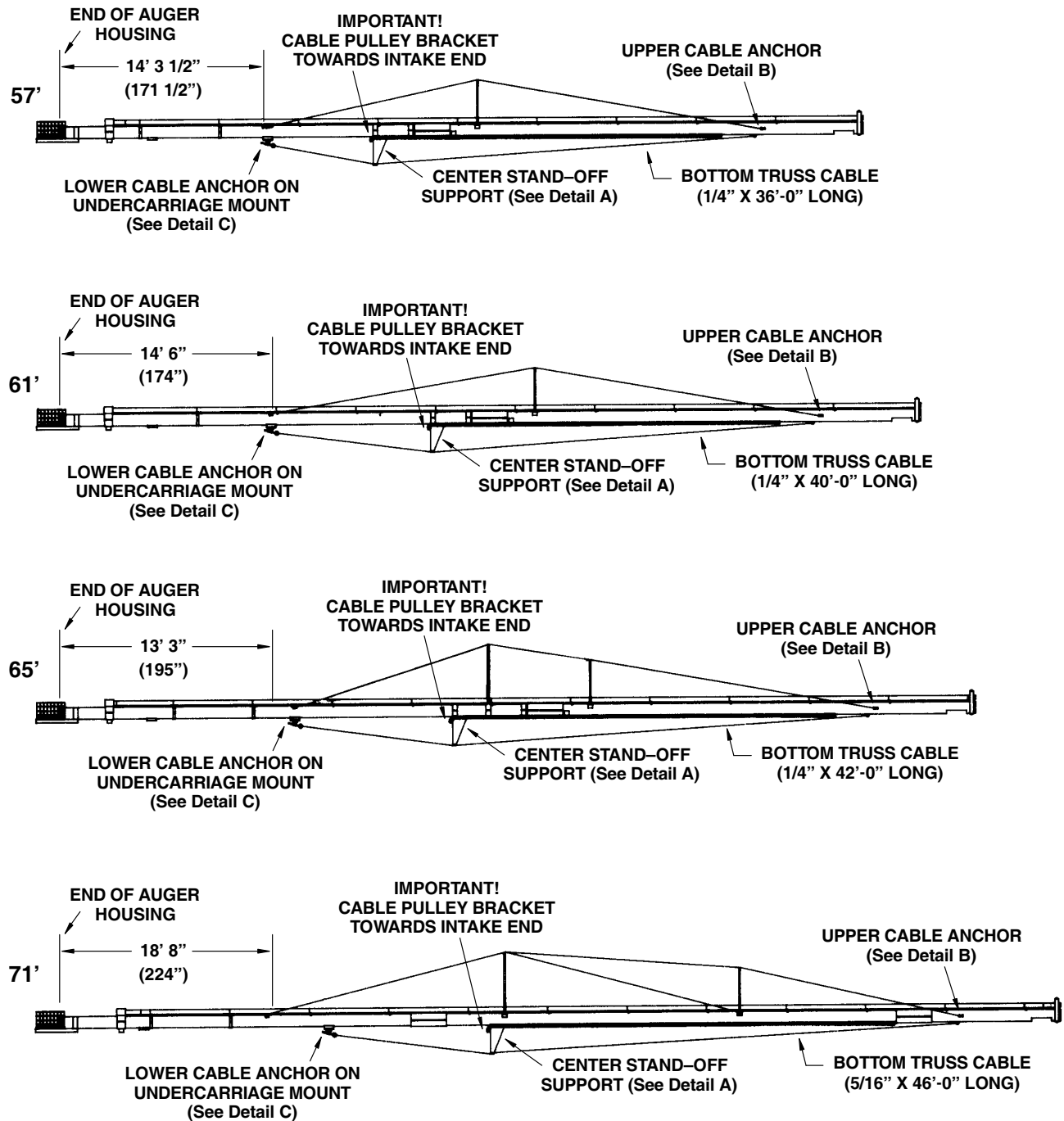

FIG. 39

ASSEMBLY INSTRUCTIONS

BOTTOM TRUSS FOR 57', 61', 65' & 71'

Step 1. Install center stand-off support to bottom side of undercarriage track. See Detail A. For center stand-off location, see Fig. 39 on page 33. Use six 3/8" x 1 1/4" long (grade 5) hex head capscrews, flat washers, lockwashers and nuts to secure center stand-off support to undercarriage track.

NOTE: Use a flat washer on the top and the bottom of each bolt.

Step 2. Attach bottom truss cable to upper anchor. See Detail B. Use an overhand knot and one cable clamp. Secure the clamp u-bolt against the loose end of the cable.

Step 3. Install eyebolt in lower anchor pipe on undercarriage mount and secure with 1/2" flat washer and two nuts. See Detail C.

Step 4. Run cable through pipe on center stand-off and fasten to eyebolt in lower anchor. Secure cable with an overhand knot and one cable clamp. Attach the clamp u-bolt against the loose end of the cable.

Step 5. Use eyebolt to tighten cable to remove "sag" from auger assembly. **DO NOT** overtighten.

Step 6. After truss is tight, the support used to lift the auger can be removed and auger will be able to stand unsupported.

DETAIL A
Center Stand-Off

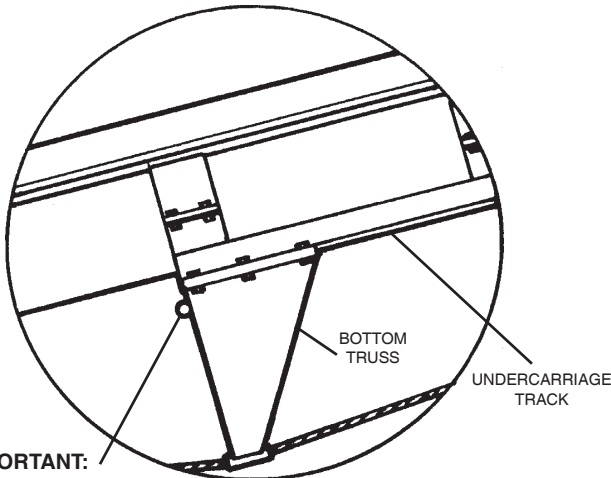

DETAIL B
Upper Cable Anchor

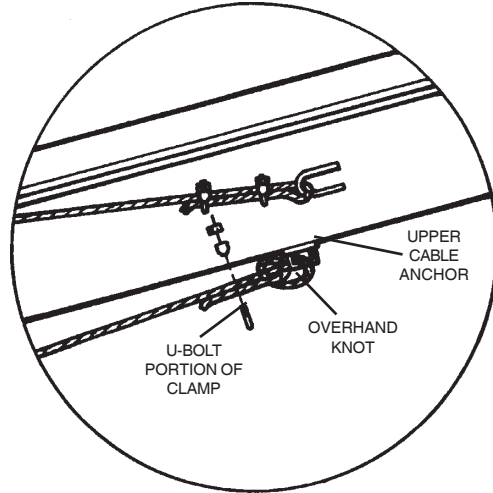

DETAIL C
Lower Cable Anchor

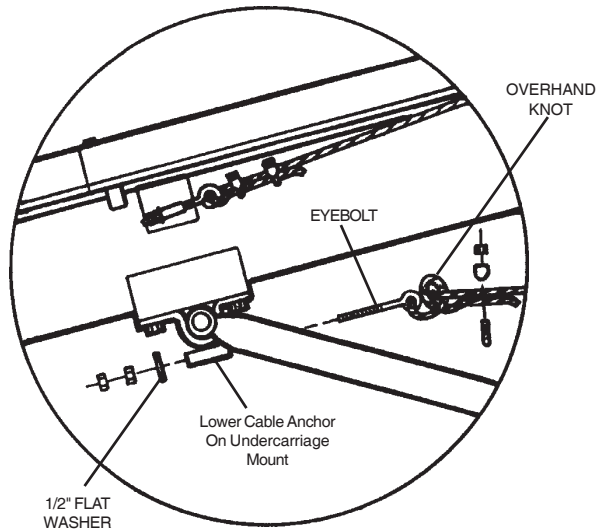

WINCH HANDLE TO WINCH BODY ASSEMBLY

Align slot of handle with flat portion of winch pinion shaft. Use hex nut to hold handle in place and tighten securely. See Fig. 40 for additional winch information. Follow the instructions and precautions listed in the material supplied with the winch from the manufacturer.

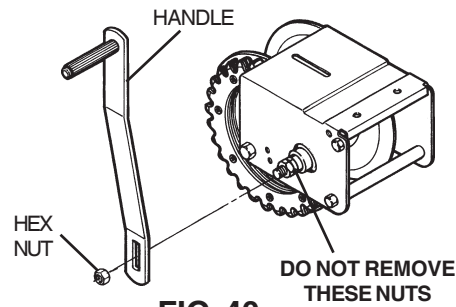

FIG. 40

LIFT CABLE TO WINCH DRUM ASSEMBLY

On 31', 35', 41', 51' & 57' Models, attach 1/4" lift cable to winch drum, so cable will wrap under winch drum, when turning winch handle in clockwise direction.

On 61', 65' & 71' Models, attach 1/4" lift cable to winch drum, so cable will wrap over winch drum, when turning winch handle in clockwise direction. From inside of drum, insert the cable through one round hole in the drum side, until it extends 1" past the two square holes.

Next, clamp the cable to the outside of the drum with the cable keeper, using two 3/16" x 3/4" carriage bolts, lock washers and nuts. Be sure that the carriage bolt heads are on the inside of the drum. See Fig. 41.

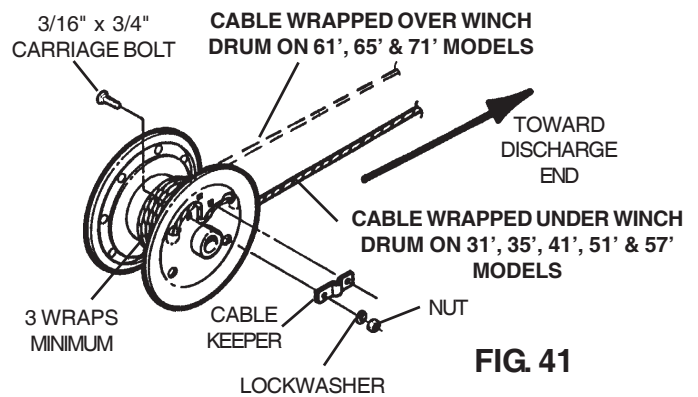

FIG. 41

⚠ Never fully extend the cable and always keep three complete turns of cable around winch drum.

WINCH TO WINCH MOUNT ON AUGER HOUSING ASSEMBLY

Bolt winch assembly to mount, so the winch drum is towards the auger discharge. Use three 3/8" x 1" long (grade 5) flat washers, lock washers and nuts to attach winch to mount. See Fig. 42.

| Winch Location | |
|----------------|--------------|
| Model Size | "A" |
| 31' | 4'-8" (56") |
| 35' | 4'-8" (56") |
| 41' | 4'-8" (56") |
| 51' | 6'-2" (74") |
| 57' | 7'-10" (94") |
| 61' | 7'-6" (90") |
| 65' | 9'-2" (110") |
| 71' | 9'-2" (110") |

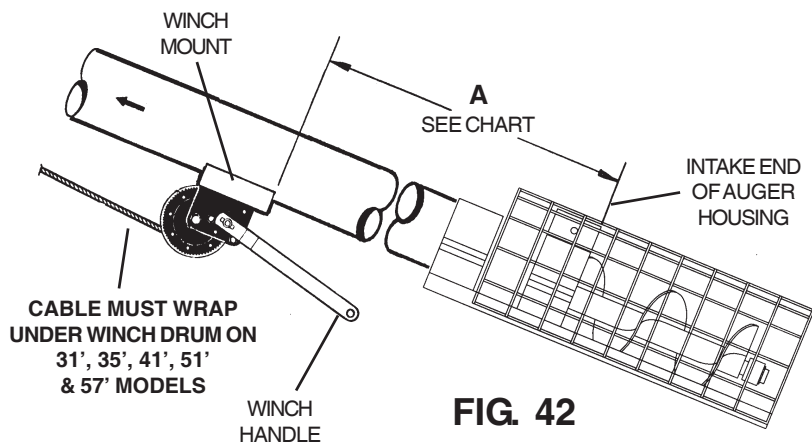

FIG. 42

ASSEMBLY INSTRUCTIONS

LIFT CABLE RIGGING

Step 1. Rig the lift cable around the cable pulleys. Different lengths of auger will require different rigging. Use the chart to determine the proper rigging pattern for your model of auger.

Step 2. Install lift cable to undercarriage slide using two 1/4" cable clamps. NOTE: Secure the clamp u-bolts against the loose end of the cable.

| Model Size | Cable Length |
|------------|--------------|
| 31' | 33' |
| 35' | 33' |
| 41' | 44' |
| 51' | 75' |
| 57' | 82' |
| 61' | 93' |
| 65' | 98' |
| 71' | 115' |

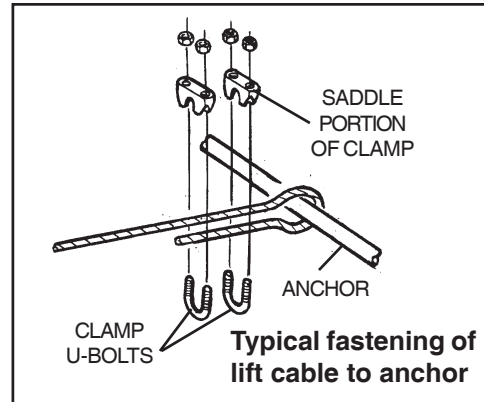

31', 35' & 41'

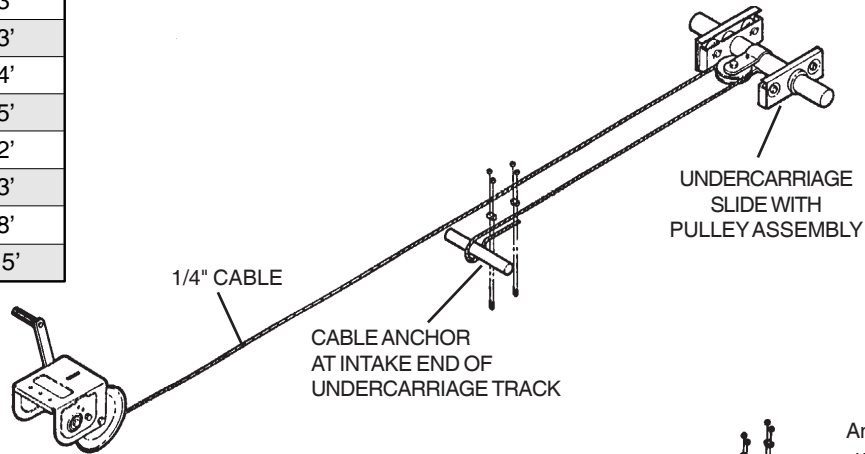

51'

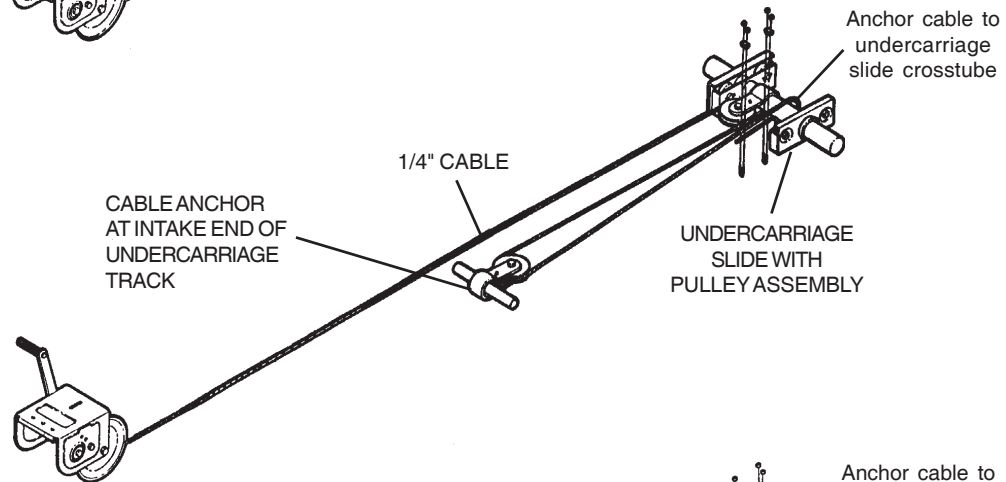

57', 61', 65' & 71'

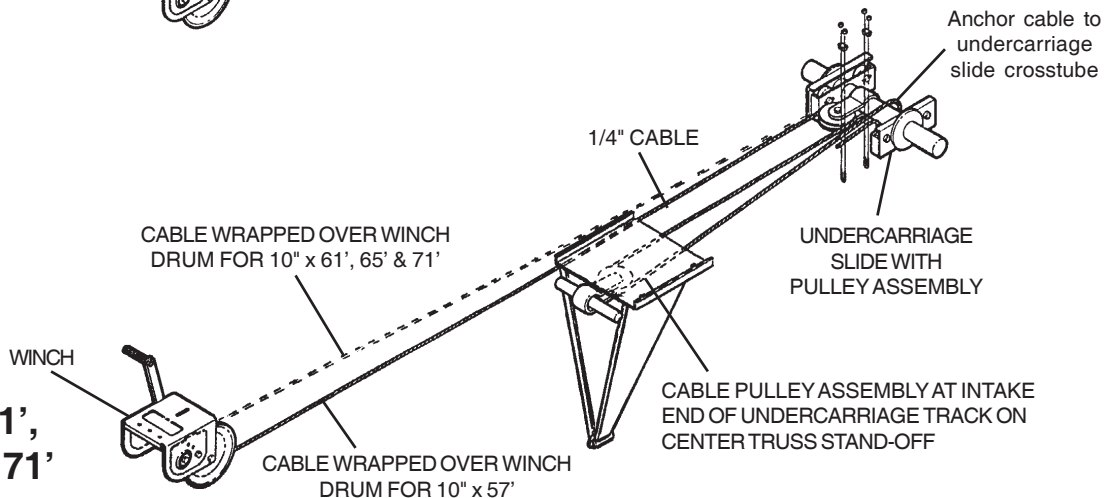

DIRECT PTO DRIVE ASSEMBLY

NOTE: P.T.O. Drives can be driven from either the right or left hand side of the auger. **ALL ILLUSTRATIONS SHOW GEARBOX IN LEFT DRIVE POSITION.**

To change the drive for a right hand drive, turn the gearbox over and bolt the other side to the gearbox mount. The vent plug in the gearbox must be put on the top side of the box. The PTO driveline support is installed on the other side of the auger housing.

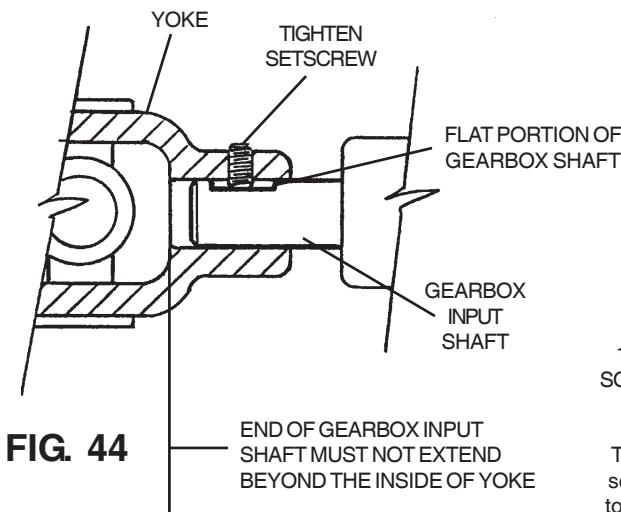

FIG. 44

Before engaging P.T.O. be sure that PTO driveline shields turn freely on the shaft.

Step 1. Attach PTO driveline to gearbox, using 1/4" x 1-1/2" long square drive key.

IMPORTANT: For setscrew to be properly engaged on the gearbox input shaft, the gearbox input shaft **MUST** be slid into the driveline yoke until the setscrew will sit in flat portion of gearbox input shaft. See Fig. 44. **DO NOT** extend the gearbox input shaft beyond the inside end of the yoke.

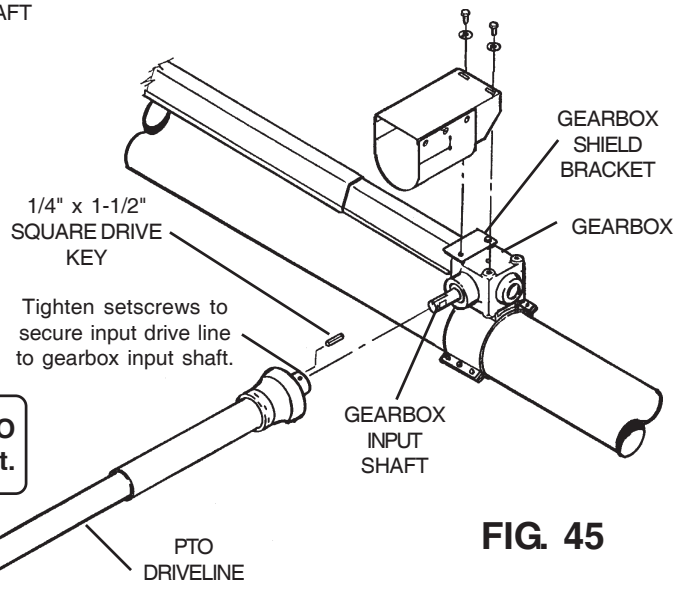

FIG. 45

Step 2. Remove 3/8" x 3/4" long (grade 5) hex head capscrews that hold the gearbox shield bracket to the top of the gearbox.

Step 3. Slide input shaft shield over end of PTO driveline, then install the shield onto the gearbox shield bracket. Replace the 3/8" x 3/4" long (grade 5) hex head capscrews, lockwashers and install flat washers.

Step 4. Place the PTO driveline support 46" up the auger housing from center of gearbox and attach in place using a halfband and two 5/16" x 1-1/2" long (grade 5) hex head capscrews and nuts. Be sure support is not installed where it is covering a safety sign. Position PTO driveline support to the auger, so that PTO driveline is parallel with the drive shaft cover. See Fig. 46 on page 38.

Step 5. Install retaining pin by slipping the short bent end of pin through hole in PTO driveline support and through slot of other side. Allow long end of pin to rotate down. This will secure pin in place. Set PTO driveline into the support to be sure support is installed properly. See Fig. 46 on page 38.

NOTE: The PTO driveline is equipped with a shear bolt at the tractor connection. The shear bolt protects the auger from damage if the auger becomes plugged or subjected to high loads. It is important to use the correct replacement bolt of the proper size and strength to insure that the shear device will protect the auger and operator.

Order replacement shear bolt, Part No. 33046 - 5/16" - 18 x 1" long Grade 5 bolt.

ASSEMBLY INSTRUCTIONS

DIRECT PTO DRIVE ASSEMBLY - CONT.

IMPORTANT:
DO NOT INSTALL THE SUPPORT WHERE THE BANDS WILL COVER ANY SAFETY SIGNS ON THE AUGER HOUSING.

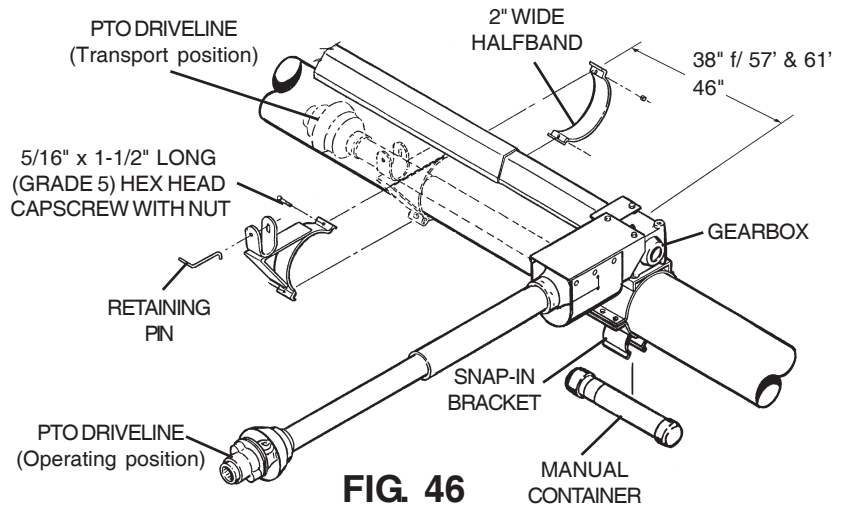

FIG. 46

TOP MOUNTED ELECTRIC MOTOR DRIVE ASSEMBLY

Assemble electric motor mount as shown in Fig. 47. See page 10 in the operating procedure portion of this manual for motor size and motor sheave size. NOTE: Motor sheave is not furnished with drive kit.

KEEP ALL SAFETY SHIELDS AND DEVICES IN PLACE.

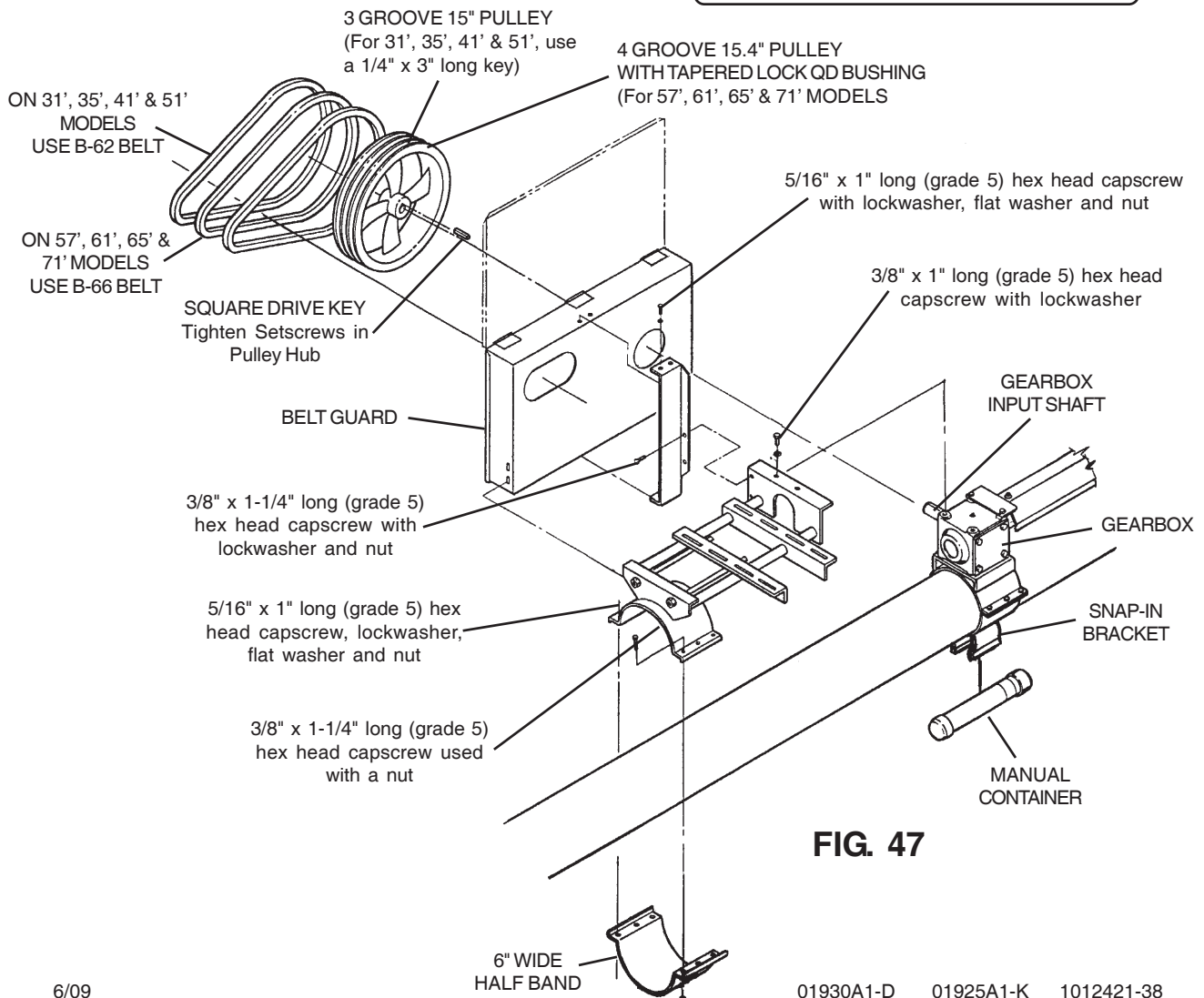

FIG. 47

UNDERSLUNG GAS ENGINE DRIVE ASSEMBLY FOR 31', 41' & 51' ONLY

Step 1. Mount underslung frame (1) to gearbox pivot ears by using pivot clamps (2) & (3) and four 3/8" x 1- 1/4" long (grade 5) hex head capscrews and nylon locknuts.

Step 2. Attach two support straps (7) to the back of underslung frame, using 3/8" x 1" long (grade 5) hex head capscrews and nylon locknuts. Then attach two support straps to the ears on the undercarriage crosstube, using 3/8" x 1" hex head capscrews and nylon locknuts.

Step 3. Connect the support straps (7) together, using two 3/8" x 1" long (grade 5) hex head capscrews and nylon locknuts per each set of straps. Adjust the support straps, so the motor mount sits level to the ground.

Step 4. Install large belt guard (4) over the three bolts welded to belt guard bracket on the pivot clamp. Use a belt guard ring (5) and three 3/8" nylon locknuts to fasten the large belt guard to the belt guard bracket. The large belt guard (4) should be allowed to pivot on the three bolts. **DO NOT COMPLETELY TIGHTEN THE NYLON LOCKNUTS DOWN AT THIS TIME.**

NOTE: Belt guard will be adjusted after belts are installed and the nylon locknuts holding the belt guard to bracket will be completely tightened then.

Step 5. Install the 15" O.D. sheave (8) to gearbox shaft, using 1/4" x 2" long square drive key. Tighten setscrews in sheave hub.

Step 6. Mount gas engine and engine sheave. **ENGINE SHEAVE NOT FURNISHED.** See page 10 in the operating procedure portion of this manual for engine horsepower and engine sheave information.

IMPORTANT: Use the proper size and speed motor to ensure satisfactory conveyor auger operation. Too small of a motor will not supply the horsepower required to achieve capacity and possible damage to the motor will occur. Too large of a motor may cause high stress on auger components, resulting in shorter life for those components.

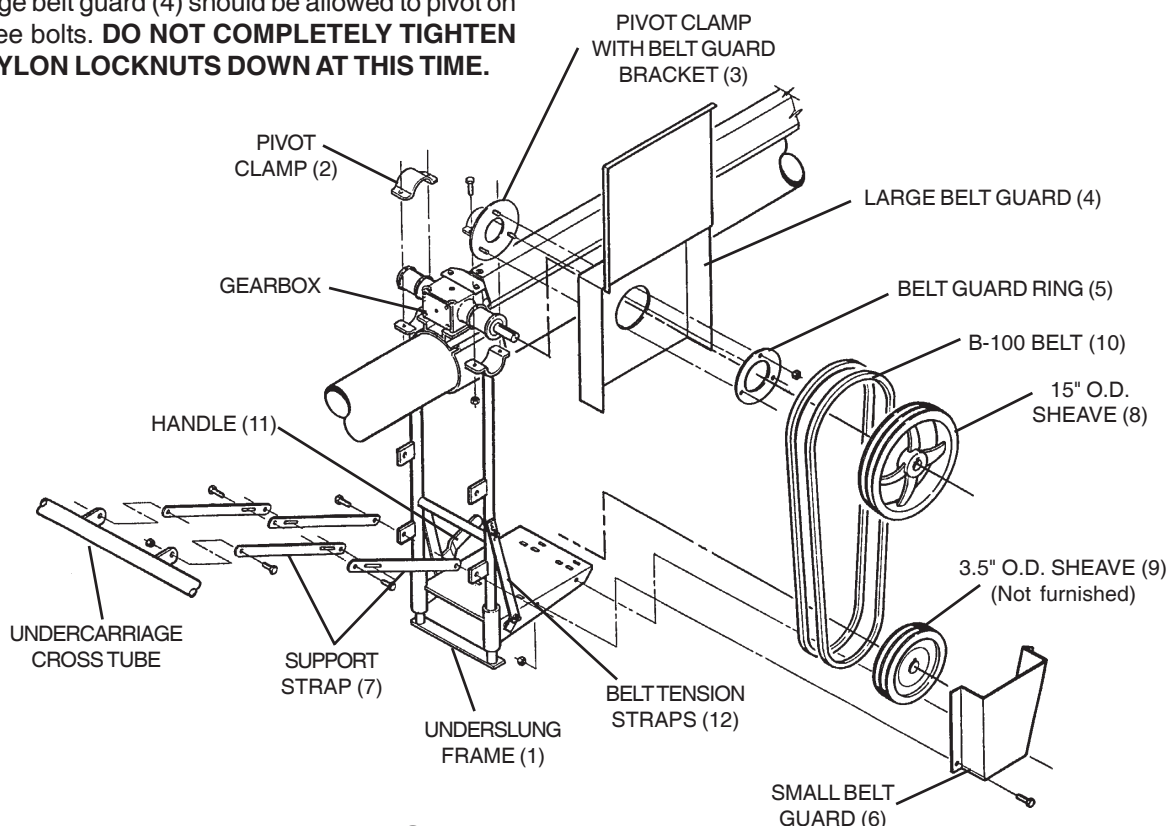

FIG. 48

ASSEMBLY INSTRUCTIONS

UNDERSLUNG GAS ENGINE DRIVE ASSEMBLY FOR 31', 41' & 51' MODELS ONLY

Step 7. Align sheaves by using a straight edge, placed across the outer faces of both sheaves. Install belts (10) and tighten. To tighten belt, first engage the motor mount handle (11) by rotating down until the handle locks over center. Check the belt tension. Disengage the motor mount handle (11) by rotating up. Adjust the belt tension by using the holes in the top belt tension straps (12) located on both sides of underslung frame. Check belt tension again after adjustments have been made. **DO NOT OVERTIGHTEN BELTS OR EXCESSIVE WEAR OR DAMAGE WILL OCCUR.**

Step 8. Mount small belt guard (6) to motor mount plate, using two 5/16" x 3/4" long (grade 5) hex head capscrews and nylon locknuts.

Step 9. Adjust the large belt guard (4), so it is not rubbing on the belts and tighten the three 3/8" nylon locknuts holding the belt guard ring (5) secure.

OPERATOR'S MANUAL CONTAINER

A plastic container with removable caps is provided to store a copy of the operator's manual on the auger.

A snap-in bracket is used to attach the container to the auger housing. This bracket is positioned in different locations, depending on the drive used to power the auger.

Direct PTO Drive - The snap-in bracket is welded to the bottom halfband used to fasten the gearbox mount to the auger housing. See Fig. 46 on page 38.

Top Mounted Electric Drive - The snap-in bracket is welded to the bottom halfband used to fasten the gearbox mount to the auger housing. See Fig. 47 on page 38.

Underslung Gas Engine Drive 31', 41' & 51' Models Only - The snap-in bracket is welded to a halfband, which is mounted to the auger housing 45" from intake end of the auger. See Fig. 20 on page 26.

TO DEALER/ASSEMBLER NOTICE

The assembly of the auger is complete if all the applicable assembly steps in this manual have been followed.

Before delivery to the owner, it is a good practice to check the following:

- a. Be sure all safety shields and devices are installed properly.
- b. Check all safety decals to see if they are clean and readable. If any are missing, damaged, painted over, etc., replace them. See page P-1 and P-3 for safety sign location. Decals may be obtained from your dealer, distributor or ordered from the factory.
- c. Check all bolts and fasteners to see they are tightened and secured properly.
- d. Check that the Operator's Manual container (with Operator's Manual inside) is installed in its holder located on the auger housing.

Deliver this Operator's Manual to the owner, along with the auger.

TO THE OWNER

Use this Assembly Section as a reference to determine that the auger is assembled properly.

Make sure an Operator's Manual is delivered, along with the auger. Anyone who will operate or work around a portable auger shall first read the Operator's Manual! Failure to read the manual and its safety instructions is a misuse of the equipment.

SAFETY SIGNS & DECALS

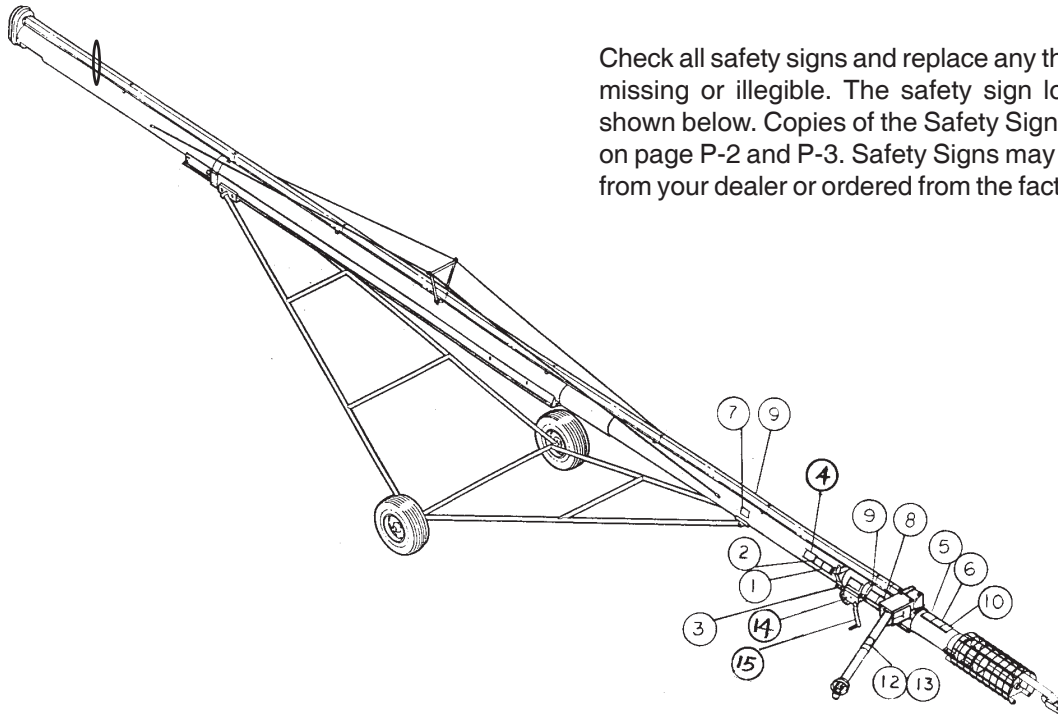

Check all safety signs and replace any that are worn, missing or illegible. The safety sign locations are shown below. Copies of the Safety Signs are shown on page P-2 and P-3. Safety Signs may be obtained from your dealer or ordered from the factory.

| REF. NO. | PART NO. | QTY. | DESCRIPTION | SIZE |
|----------|----------|--------|---|---------------|
| 1 | 1001973 | 1 | CAUTION - GENERAL STATEMENTS 1-8 One on side of Auger Housing | 4-3/4 x 8 |
| 2 | 1001980 | 1 | DANGER - BEWARE OF POWER LINES One on side of Auger Housing | 4 x 8 |
| 3 | 1001978 | 1 | WARNING - HAND WINCH OPERATION One on Auger Housing | 4 x 7-1/4 |
| 4 | 1005324 | 1 | DANGER "STOP" IF ANY GUARDS, SHIELDS 4 x 6 One on side of Auger Housing | 4 x 6 |
| 5 | 1001981 | 1 | DANGER - UPENDING HAZARD One on Auger Housing | 4-1/2 x 6-1/4 |
| 6 | 1001985 | 1 | DANGER - ROTATING AUGER One on Auger Housing | 4-1/2 x 6-1/4 |
| 7 | 1001984 | 1 | DANGER - DO NOT ATTEMPT DISASSEMBLY One on side of Auger Housing | 4 x 6 |
| 8 | 1001983 | 1 | DANGER - ROTATING DRIVE LINE One on side of Auger Housing | 4 x 6-1/4 |
| 9 | 1001982 | 2 | DANGER - ROTATING SHAFT One on both sides of Auger Housing | 4 x 7-1/4 |
| 10 | 1001975 | 1 | WARNING - THE TRANSPORT WIDTH One on Auger Housing of units longer than 57' | 4 x 6 |
| *11 | 100198 | VARIES | "DANGER - DO NOT REMOVE COVER (Near Internal Bearing Inspection Opening) | 4 x 6 |
| 12 | 13-10022 | 1 | DANGER - SHIELD MISSING Under PTO Driveline Shield | — |
| 13 | 13-10021 | 1 | DANGER - ROTATING DRIVELINE On PTO Driveline Shield | — |
| 14 | 1002805 | 1 | CAUTION - CABLE OUT/CABLE IN | — |
| 15 | 2169A1 | 1 | CAUTION - WINCH OPERATION On Hand Winch Handle | — |

*ONLY USED ON AUGERS WITH OPTIONAL INTERNAL BEARINGS

PARTS LIST

SAFETY SIGNS & DECALS

1

CAUTION

1. READ AND UNDERSTAND THE OPERATOR'S MANUAL BEFORE OPERATING.
2. DO NOT REMOVE OR MODIFY ANY GUARDS.
3. MAKE CERTAIN EVERYONE IS CLEAR BEFORE OPERATING OR MOVING THE MACHINE.
4. KEEP HANDS, FEET, HAIR AND CLOTHING AWAY FROM MOVING PARTS.
5. STOP MACHINE AND LOCKOUT POWER TO ADJUST, SERVICE OR CLEAN.
6. EMPTY MACHINE AND LOWER TO TRANSPORT POSITION FOR TRANSPORTING.
7. DO NOT ATTEMPT TO MOVE MACHINE MANUALLY. USE A TOWING VEHICLE.
8. KEEP CHILDREN WELL CLEAR OF WORK AREA.

3

WARNING



(FOR HYDRAULIC OR ELECTRIC WINCH OPERATION, PLEASE REFER TO THE OPERATOR'S MANUAL PROVIDED WITH UNIT.)

- AFTER LOWERING THE UNIT, ALWAYS TURN THE WINCH HANDLE CLOCKWISE UNTIL YOU HEAR AT LEAST TWO CLICKS. THIS TIGHTENS THE BRAKE LOCK.
- MAINTAIN CONTROL OF WINCH HANDLE AT ALL TIMES.
- DO NOT PUT LUBRICATION OF ANY KIND ON THE BRAKE DISC.
- CHECK CABLE BEFORE EACH USE. REPLACE IF FRAYED OR DAMAGED.
- MAINTAIN LIGHT CABLE TENSION WHEN TRANSPORTING.

FAILURE TO HEED WILL RESULT IN SERIOUS INJURY OR DEATH!

1001878

2

DANGER

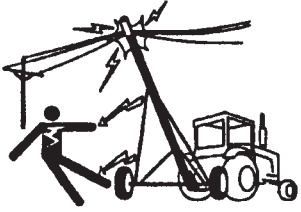

**BEWARE OF POWER LINES
ELECTROCUTION HAZARD**

- THIS MACHINE IS NOT INSULATED.
- KEEP AT LEAST 10 FEET AWAY FROM OVERHEAD ELECTRICAL WIRES.
- ELECTROCUTION CAN OCCUR WITHOUT DIRECT CONTACT.

**FAILURE TO HEED WILL
RESULT IN SERIOUS INJURY
OR DEATH!**

100088

4

DANGER



IF ANY GUARDS, SHIELDS OR SAFETY DECALS ARE DAMAGED OR MISSING, ORDER FREE REPLACEMENTS BY CALLING

1-800-523-6993
OR WRITE TO:
HUTCHINSON/MAYRATH
P.O. BOX 629
CLAY CENTER, KANSAS 67432

1005324

5

DANGER



UPENDING HAZARD

- SUPPORT DISCHARGE END OR ANCHOR INTAKE END TO PREVENT UPENDING.
- EMPTY MACHINE BEFORE MOVING.
- DO NOT PUSH THE UNDERCARRIAGE BY HAND.
- LIFT THE INTAKE END SLOWLY AND NEVER HIGHER THAN VEHICLE TOW BAR. MAINTAIN CONTROL UNTIL SECURELY ATTACHED TO TOW BAR OR RESTING ON THE GROUND.
- LOWER TO TRANSPORT POSITION IMMEDIATELY WHEN CLEAR FROM GRAIN STORAGE STRUCTURE.

**FAILURE TO HEED WILL RESULT
IN SERIOUS INJURY OR DEATH!**

1001921

6

DANGER



ROTATING AUGER

- KEEP HANDS, FEET, HAIR AND CLOTHING AWAY FROM ROTATING AUGER.
- DO NOT REMOVE OR MODIFY ANY GUARDS.
- KEEP CHILDREN WELL CLEAR OF WORK AREA

**FAILURE TO HEED WILL
RESULT IN SERIOUS
INJURY OR DEATH!**

1004000

8

DANGER



ROTATING DRIVELINE

- KEEP BODY, HAIR AND CLOTHING AWAY FROM ROTATING DRIVELINE.
- USE ONLY WITH AGRICULTURAL TRACTOR HAVING 540 RPM POWER TAKE OFF.
- KEEP ALL DRIVELINE, TRACTOR AND EQUIPMENT GUARDS IN PLACE.
- MAKE SURE DRIVELINE IS SECURELY ATTACHED AT BOTH ENDS.
- MAKE SURE DRIVELINE SHIELDS TURN FREELY ON DRIVELINE.
- KEEP U-JOINT ANGLES SMALL AND EQUAL.
- KEEP CHILDREN WELL CLEAR OF WORK AREA.

**FAILURE TO HEED WILL RESULT IN
SERIOUS INJURY OR DEATH!**

1001900

SAFETY SIGNS & DECALS

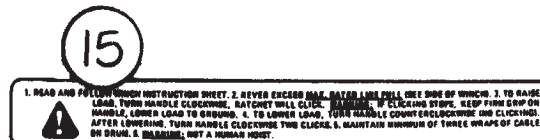
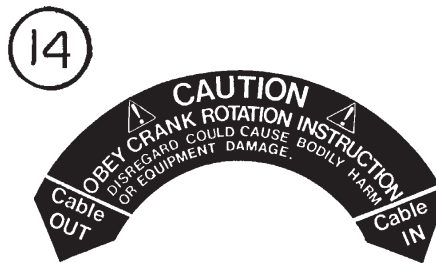
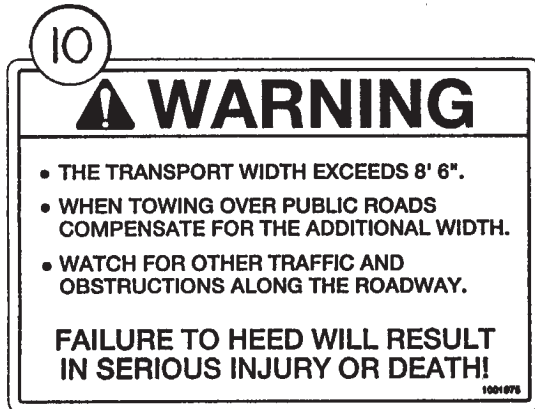
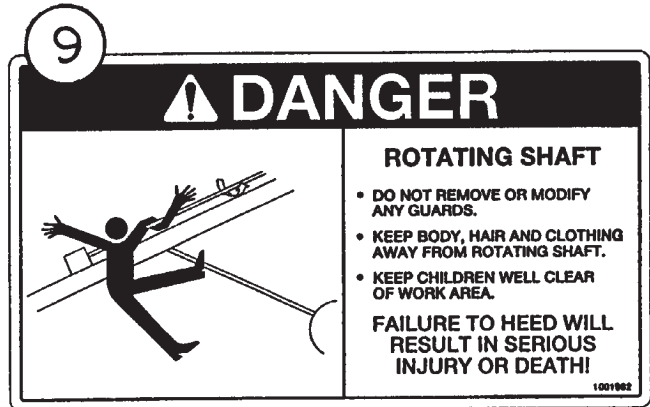

PARTS LIST

MAIN AUGER COMPONENTS

ENCLOSED HEAD DRIVE

| | |
|-------------------------------------|-------------------------------------|
| STANDARD DRIVE | OPTIONAL REDUCTION DRIVE |
| COMPLETE PART NO. 1001495 | COMPLETE PART NO. 1001845 |

| <u>REF. NO.</u> | <u>DESCRIPTION</u> | <u>RATIO 1 TO 1 PART NO.</u> | <u>RATIO 2 TO 1 PART NO.</u> |
|-----------------|---|----------------------------------|----------------------------------|
| 1 | Aluminum Casting | 1001523 | 1001523 |
| 2 | Aluminum Casting - Cover | 1001522 | 1001522 |
| 3 | #80 Roller Chain - 34 pitch | 41380 | N/A |
| 3 | #80 Roller Chain - 37 pitch | N/A | 1001848 |
| 4 | Gasket | 1001573 | 1001573 |
| 5 | 3/8" Plug | 458026 | 458026 |
| 6 | 1-1/4" Bearing Cone (Timken No. 15123) | 106322 | 106322 |
| 7 | 1-1/2" Bearing Cone (Timken No. LM29749) | 035439 | 035439 |
| 8 | 1-1/2" Bore Sprocket - 17 tooth | 1001576 | N/A |
| 8 | 1-1/2" Bore Sprocket - 26 tooth | N/A | 1012501 |
| 9 | Stub Shaft 1-1/2" | 1001574 | 1001574 |
| 10 | Stub Shaft 1-1/4" | 1001575 | 1001575 |
| 11 | 1-1/4" Bore Sprocket - 17 tooth | 1002299 | N/A |
| 11 | 1-1/4" Bore Sprocket - 13 tooth | N/A | 1012500 |
| 12 | 5/16" x 1-1/4" HHCS | 4727-1 | 4727-1 |
| 13 | 5/16" Lockwasher | 33144 | 33144 |
| 14 | 5/16" x 2 1/2" Roll Pin | 33190 | 33190 |
| 15 | Shaft Seal - 1-1/2" | 035860 | 035860 |
| 16 | Shaft Seal - 1-1/4" | 835168 | 835168 |
| 17A | Square Key, 1/4" x 1" | 4020A1 | 4020A1 |
| 17B | Square Key, 3/8" x 1" | 1002276 | 1002276 |
| 18 | Decal Notice Oil Level | 1002275 | 1002275 |
| 19 | 1-1/4" Bearing Cup (Timken No. 15245) | 106323 | 106323 |
| 20 | 1-1/2" Bearing Cup (Timken No. LM29710) | 035440 | 035440 |
| 21 | Non-Lock Nut 5/16" | 33151 | 33151 |
| 22 | 3/8" Pipe Plug - Vented | 1001438 | 1001438 |
| *23 | Drive Shaft Mounting Clip | 553630 | 553630 |
| *24 | Self-Tapping Screw | 33183 | 33183 |
| *25 | 4" long Coupler (1" to 1-1/4") | 1002383 | 1002383 |
| *26 | Key 1/4" x 1-1/2" | 8371C | 8371C |
| 27 | Decal - 2 to 1 Ratio | N/A | 1012528 |

*Indicates items that are not part of the assembly number.
These items are sold separately.

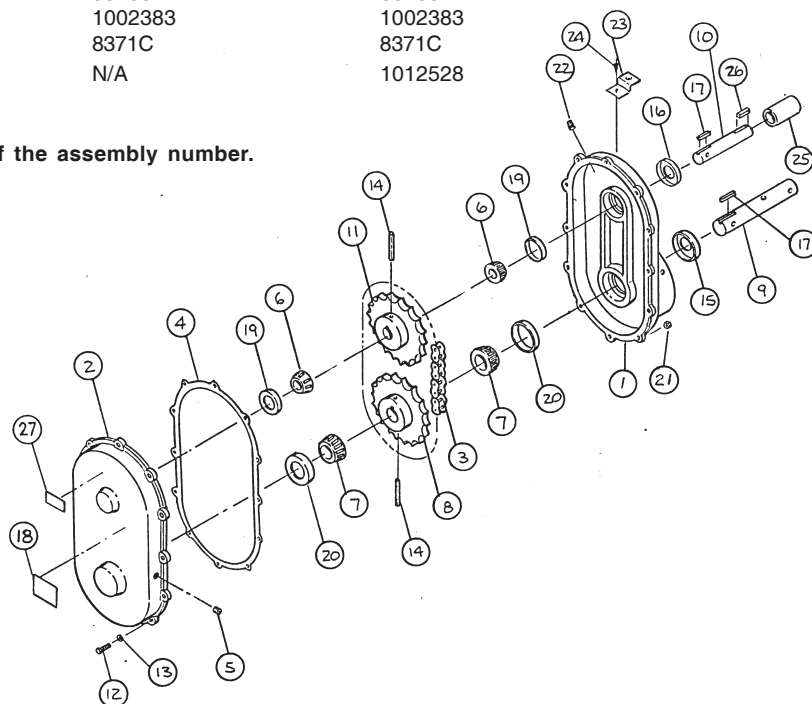

PARTS LIST

MAIN AUGER COMPONENTS

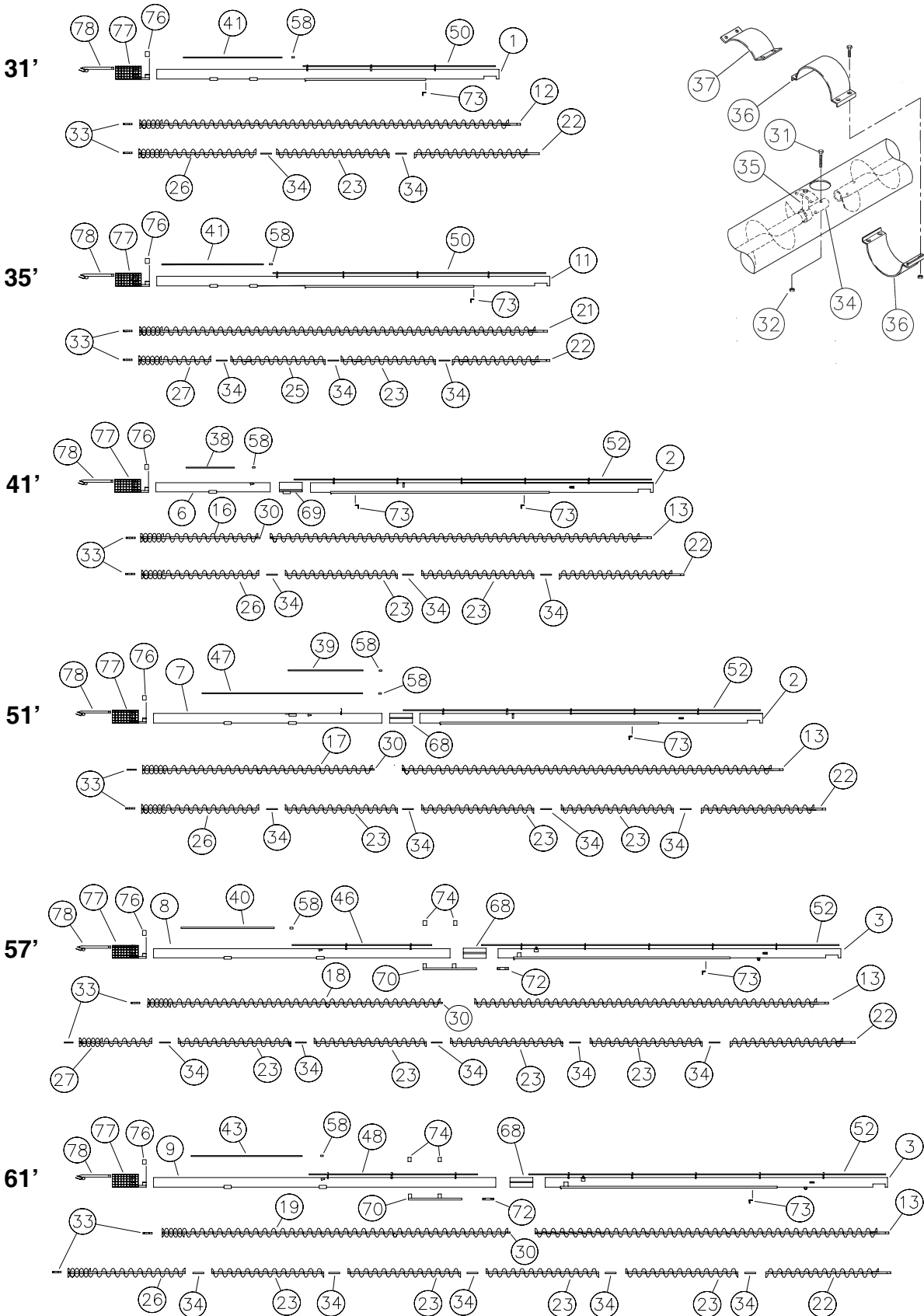

PARTS LIST

MAIN AUGER COMPONENTS

NOTE: Auger housings shown with drive shaft attached are supplied with the specified drive shaft and drive shaft bearings.

MAYRATH HOUSINGS

STANDARD 14 GA. GALV. TUBING

| REF. NO. | PART NO. | DESCRIPTION |
|----------|-------------|--|
| 1 | -- | 10" Galv. Housing (Single Section) |
| -- | 1009948-G | f/31' (30'-0" long) |
| 2-4 | -- | 10" Galv. Housing, Upper |
| 2 | 1003603-G | f/41' & 51' (30'-0" long) |
| -- | 1012440-G | f/41' w/Underslung Gas (30'-0" long) |
| -- | 1007558-320 | f/51' w/Underslung Gas (32'-6 1/2" lg) |
| 3 | 1009949-G | f/57', 61' & 65' (30'-0" long) |
| 4 | 1003605-G | f/71' (10'-0" long) |
| 5 | -- | 10" Galv. Housing, Center |
| -- | 1003607-G | f/71' (34'-0" long) |
| 6-11 | -- | 10" Galv. Housing, Lower |
| 6 | 1003619-G | f/41' (10'-0" long) |
| 7 | 1003620-G | f/51' (20'-0" long) |
| -- | 1035904-320 | f/51' w/Underslung Gas Drive |
| -- | 1003621-G | f/51' w/Corn Screens f/PTO & Electric Drive (20'-0" long) |
| 8 | 1009950-G | f/57' (26'-0" long) |
| -- | 1009951-G | f/57' w/Corn Screens f/PTO & Electric Drive (26'-0" long) |
| 9 | 1009952-G | f/61' (30'-0" long) |
| -- | 1009953-G | f/61' w/Corn Screens f/PTO & Electric Drive (30'-0" long) |
| 10 | 1009954-G | f/65' (34'-0" long) |
| -- | 1009955-G | f/65' w/Corn Screens f/PTO & Electric Drive (34'-0" long) |
| 11 | 1003626-G | f/71' (26'-0" long) |
| -- | 1034444-320 | f/35' (Single Section) |

HUTCHINSON HOUSINGS

STANDARD 14 GA. GALV. TUBING

| REF. NO. | PART NO. | DESCRIPTION |
|----------|-------------|---|
| 1 | -- | 10" Galv. Housing (Single Section) |
| -- | 1009879-G | f/31' (30'-0" long) |
| 2-4 | -- | 10" Galv. Housing, Upper |
| 2 | 1003563-G | f/41' & 51' (30'-0" long) |
| -- | 1012441-G | f/41' w/Underslung Gas (30'-0" long) |
| -- | 1029193-220 | f/51' w/Underslung Gas (32'-6 1/2" lg) |
| 3 | 1009880-G | f/57', 61' & 65' (30'-0" long) |
| 4 | 1003565-G | f/71' (10'-0" long) |
| 5 | -- | 10" Galv. Housing, Center |
| -- | 1003567-G | f/71' (34'-0" long) |
| 6-11 | -- | 10" Galv. Housing, Lower |
| 6 | 1003579-G | f/41' (10'-0" long) |
| 7 | 1003580-G | f/51' (20'-0" long) |
| -- | 1035904-220 | f/51' w/Underslung Gas Drive |
| -- | 1003581-G | f/51' w/Corn Screens f/PTO & Elec. Drive (20'-0" long) |
| 8 | 1009881-G | f/57' (26'-0" long) |
| -- | 1009882-G | f/57' w/Corn Screens f/PTO & Elec. Drive (26'-0" long) |
| 9 | 1009883-G | f/61' (30'-0" long) |
| -- | 1009884-G | f/61' w/Corn Screens f/PTO & Elec Drive (30'-0" long) |
| 10 | 1009885-G | f/65' (34'-0" long) |
| -- | 1009886-G | f/65' w/Corn Screens f/PTO & Elec. Drive (34'-0" long) |
| 11 | 1003586-G | f/71' (26'-0" long) |
| -- | 1034444-220 | f/35' (Single Section) |

MAYRATH HOUSINGS

OPTIONAL 12 GA. GALV. TUBING

| REF. NO. | PART NO. | DESCRIPTION |
|----------|-------------|--|
| 1 | -- | 10" Galv. Housing |
| -- | 1009948-G9 | f/31' (30'-0" long) |
| 2-4 | -- | 10" Galv. Housing, Upper |
| 2 | 1003603-G9 | f/41' & 51' (30'-0" long) |
| -- | 1012440-G9 | f/41' w/Underslung Gas (30'-0" long) |
| -- | 1007558-330 | f/51' w/Underslung Gas (32'-6 1/2" lg) |
| 3 | 1009949-G9 | f/57', 61' & 65' (30'-0" long) |
| 4 | 1003605-G9 | f/71' (10'-0" long) |
| 5 | -- | 10" Galv. Housing, Center |
| -- | 1003607-G9 | f/71' (34'-0" long) |
| 6-11 | -- | 10" Galv. Housing, Lower |
| 6 | 1003619-G9 | f/41' (10'-0" long) |
| 7 | 1003620-G9 | f/51' (20'-0" long) |
| -- | 1035904-330 | f/51' w/Underslung Drive |
| -- | 1003621-G9 | f/51' w/Corn Screens f/PTO & Electric Drive (20'-0" long) |
| 8 | 1009950-G9 | f/57' (26'-0" long) |
| -- | 1009951-G9 | f/57' w/Corn Screens f/PTO & Electric Drive (26'-0" long) |
| 9 | 1009952-G9 | f/61' (30'-0" long) |
| -- | 1009953-G9 | f/61' w/Corn Screens f/PTO & Electric Drive (30'-0" long) |
| 10 | 1009954-G9 | f/65' (34'-0" long) |
| -- | 1009955-G9 | f/65' w/Corn Screens f/PTO & Electric Drive (34'-0" long) |
| 11 | 1003626-G9 | f/71' (26'-0" long) |
| -- | 1034444-330 | f/35' (Single Section) |

HUTCHINSON HOUSINGS

OPTIONAL 12 GA. GALV. TUBING

| REF. NO. | PART NO. | DESCRIPTION |
|----------|-------------|---|
| 1 | -- | 10" Galv. Housing |
| -- | 1009879-G9 | f/31' (30'-0" long) |
| 2-4 | -- | 10" Galv. Housing, Upper |
| 2 | 1003563-G9 | f/41' & 51' (30'-0" long) |
| -- | 1012441-G9 | f/41' w/Underslung Gas (30'-0" long) |
| -- | 1029193-230 | f/51' w/Underslung Gas (32'-6 1/2" lg) |
| 3 | 1009880-G9 | f/57', 61' & 65' (30'-0" long) |
| 4 | 1003565-G9 | f/71' (10'-0" long) |
| 5 | -- | 10" Galv. Housing, Center |
| -- | 1003567-G9 | f/71' (34'-0" long) |
| 6-11 | -- | 10" Galv. Housing, Lower |
| 6 | 1003579-G9 | f/41' (10'-0" long) |
| 7 | 1003580-G9 | f/51' (20'-0" long) |
| -- | 1035904-230 | f/51' w/Underslung Drive |
| -- | 1003581-G9 | f/51' w/Corn Screens f/PTO & Elec. Drive (20'-0" long) |
| 8 | 1009881-G9 | f/57' (26'-0" long) |
| -- | 1009882-G9 | f/57' w/Corn Screens f/PTO & Elec. Drive (26'-0" long) |
| 9 | 1009883-G9 | f/61' (30'-0" long) |
| -- | 1009884-G9 | f/61' w/Corn Screens f/PTO & Elec Drive (30'-0" long) |
| 10 | 1009885-G9 | f/65' (34'-0" long) |
| -- | 1009886-G9 | f/65' w/Corn Screens f/PTO & Elec. Drive (34'-0" long) |
| 11 | 1003586-G9 | f/71' (26'-0" long) |
| -- | 1034444-230 | f/35' (Single Section) |

NOTE: Housings for Optional Internal Bearing Units are listed on the following page.

PARTS LIST**MAIN AUGER COMPONENTS**

(NOTE: Auger housings shown with drive shaft attached are supplied with the specified drive shaft and drive shaft bearings.)

**MAYRATH HOUSINGS
FOR OPTIONAL INTERNAL BEARINGS
STANDARD 14 GA. GALV. TUBING**

| REF. NO. | PART NO. | DESCRIPTION |
|----------|-------------|--|
| 1 | -- | 10" Galv. Housing (Single Section) |
| -- | 1009948-G5 | f/31' (30'-0" long) |
| 2-4 | -- | 10" Galv. Housing, Upper |
| 2 | 1003603-G5 | f/41' & 51' (30'-0" long) |
| -- | 1012440-G5 | f/41' w/Underslung Drive (30'-0" long) |
| 3 | 1009949-G5 | f/57', 61' & 65' (30'-0" long) |
| 4 | 1003605-G5 | f/71' (10'-0" long) |
| 5 | -- | 10" Galv. Housing, Center |
| -- | 1003607-G5 | f/71' (34'-0" long) |
| 6-11 | -- | 10" Galv. Housing, Lower |
| 6 | 1003619-G5 | f/41' (10'-0" long) |
| 7 | 1003620-G5 | f/51' (20'-0" long) |
| -- | 1003621-G5 | f/51' w/Corn Screens f/PTO & Electric Drive (20'-0" long) |
| 8 | 1009950-G5 | f/57' (26'-0" long) |
| -- | 1009951-G5 | f/57' w/Corn Screens f/PTO & Electric Drive (26'-0" long) |
| 9 | 1009952-G5 | f/61' (30'-0" long) |
| -- | 1009953-G5 | f/61' w/Corn Screens f/PTO & Electric Drive (30'-0" long) |
| 10 | 1009954-G5 | f/65' (34'-0" long) |
| -- | 1009955-G5 | f/65' w/Corn Screens f/PTO & Electric Drive (34'-0" long) |
| 11 | 1003626-G5 | f/71' (26'-0" long) |
| -- | 1034705-320 | f/35' (Single Section) |

**MAYRATH HOUSINGS
OPTIONAL 12 GA. GALV. TUBING**

| REF. NO. | PART NO. | DESCRIPTION |
|----------|-------------|--|
| 1 | -- | 10" Galv. Housing |
| -- | 1009948-G59 | f/31' (30'-0" long) |
| 2-4 | -- | 10" Galv. Housing, Upper |
| 2 | 1003603-G59 | f/41' & 51' (30'-0" long) |
| -- | 1012440-G59 | f/41' w/Underslung Drive (30'-0" long) |
| 3 | 1009949-G59 | f/57', 61' & 65' (30'-0" long) |
| 4 | 1003605-G59 | f/71' (10'-0" long) |
| 5 | -- | 10" Galv. Housing, Center |
| -- | 1003607-G59 | f/71' (34'-0" long) |
| 6-11 | -- | 10" Galv. Housing, Lower |
| 6 | 1003619-G59 | f/41' (10'-0" long) |
| 7 | 1003620-G59 | f/51' (20'-0" long) |
| -- | 1003621-G59 | f/51' w/Corn Screens f/PTO & Electric Drive (20'-0" long) |
| 8 | 1009950-G59 | f/57' (26'-0" long) |
| -- | 1009951-G59 | f/57' w/Corn Screens f/PTO & Electric Drive (26'-0" long) |
| 9 | 1009952-G59 | f/61' (30'-0" long) |
| -- | 1009953-G59 | f/61' w/Corn Screens f/PTO & Electric Drive (30'-0" long) |
| 10 | 1009954-G59 | f/65' (34'-0" long) |
| -- | 1009955-G59 | f/65' w/Corn Screens f/PTO & Electric Drive (34'-0" long) |
| 11 | 1003626-G59 | f/71' (26'-0" long) |
| -- | 1034705-330 | f/35' (Single Section) |

**HUTCHINSON HOUSINGS
FOR OPTIONAL INTERNAL BEARINGS
STANDARD 14 GA. GALV. TUBING**

| REF. NO. | PART NO. | DESCRIPTION |
|----------|-------------|---|
| 1 | -- | 10" Galv. Housing (Single Section) |
| -- | 1009879-G5 | f/31' (30'-0" long) |
| 2-4 | -- | 10" Galv. Housing, Upper |
| 2 | 1003563-G5 | f/41' & 51' (30'-0" long) |
| -- | 1012441-G5 | f/41' w/Underslung Drive (30'-0" long) |
| 3 | 1009880-G5 | f/57', 61' & 65' (30'-0" long) |
| 4 | 1003565-G5 | f/71' (10'-0" long) |
| 5 | -- | 10" Galv. Housing, Center |
| -- | 1003567-G5 | f/71' (34'-0" long) |
| 6-11 | -- | 10" Galv. Housing, Lower |
| 6 | 1003579-G5 | f/41' (10'-0" long) |
| 7 | 1003580-G5 | f/51' (20'-0" long) |
| -- | 1003581-G5 | f/51' w/Corn Screens f/PTO & Elec. Drive (20'-0" long) |
| 8 | 1009881-G5 | f/57' (26'-0" long) |
| -- | 1009882-G5 | f/57' w/Corn Screens f/PTO & Elec. Drive (26'-0" long) |
| 9 | 1009883-G5 | f/61' (30'-0" long) |
| -- | 1009884-G5 | f/61' w/Corn Screens f/PTO & Elec. Drive (30'-0" long) |
| 10 | 1009885-G5 | f/65' (34'-0" long) |
| -- | 1009886-G5 | f/65' w/Corn Screens f/PTO & Elec. Drive (34'-0" long) |
| 11 | 1003586-G5 | f/71' (26'-0" long) |
| -- | 1034705-220 | f/35' (Single Section) |

**HUTCHINSON HOUSINGS
OPTIONAL 12 GA. GALV. TUBING**

| REF. NO. | PART NO. | DESCRIPTION |
|----------|-------------|---|
| 1 | -- | 10" Galv. Housing |
| -- | 1009879-G59 | f/31' (30'-0" long) |
| 2-4 | -- | 10" Galv. Housing, Upper |
| 2 | 1003563-G59 | f/41' & 51' (30'-0" long) |
| -- | 1012441-G59 | f/41' w/Underslung Drive (30'-0" long) |
| 3 | 1009880-G59 | f/57', 61' & 65' (30'-0" long) " |
| 4 | 1003565-G59 | f/71' (10'-0" long) |
| 5 | -- | 10" Galv. Housing, Center |
| -- | 1003567-G59 | f/71' (34'-0" long) |
| 6-11 | -- | 10" Galv. Housing, Lower |
| 6 | 1003579-G59 | f/41' (10'-0" long) |
| 7 | 1003580-G59 | f/51' (20'-0" long) |
| -- | 1003581-G59 | f/51' w/Corn Screens f/PTO & Elec. Drive (20'-0" long) |
| 8 | 1009881-G59 | f/57' (26'-0" long) |
| -- | 1009882-G59 | f/57' w/Corn Screens f/PTO & Elec. Drive (26'-0" long) |
| 9 | 1009883-G59 | f/61' (30'-0" long) |
| -- | 1009884-G59 | f/61' w/Corn Screens f/PTO & Elec Drive (30'-0" long) |
| 10 | 1009885-G59 | f/65' (34'-0" long) |
| -- | 1009886-G59 | f/65' w/Corn Screens f/PTO & Elec. Drive (34'-0" long) |
| 11 | 1003586-G59 | f/71' (26'-0" long) |
| -- | 1034705-230 | f/35' (Single Section) |

PARTS LIST

MAIN AUGER COMPONENTS

(NOTE: Auger housings shown with drive shaft attached are supplied with the specified drive shaft and drive shaft bearings.)

MAYRATH HOUSINGS (PAINTED YELLOW)

| REF. NO. | PART NO. | DESCRIPTION |
|----------|----------|---|
| 1 | -- | 10" Painted Housing (Single Section) |
| -- | 1009948 | f/31' (30'-0" long) |
| 2-4 | -- | 10" Painted Housing, Upper |
| 2 | 1003603 | f/41' & 51' (30'-0" long) |
| -- | 1012440 | f/41' w/Underslung Drive (30'-0" long) |
| 3 | 1009949 | f/61' (30'-0" long) |
| 4 | 1003605 | f/71' (10'-0" long) |
| 5 | -- | 10" Painted Housing, Center |
| -- | 1003607 | f/71' (34'-0" long) |
| 6-11 | -- | 10" Painted Housing, Lower |
| 6 | 1003619 | f/41' (10'-0" long) |
| 7 | 1003620 | f/51' (20'-0" long) |
| -- | 1003621 | f/51' w/Corn Screens f/PTO & Elec. Drive (20'-0" long) |
| 9 | 1009952 | f/61' (30'-0" long) |
| -- | 1009953 | f/61' w/Corn Screens f/PTO & Elec. Drive (30'-0" long) |
| 11 | 1003626 | f/71' (26'-0" long) |

HUTCHINSON HOUSINGS (PAINTED RED)

| REF. NO. | PART NO. | DESCRIPTION |
|----------|----------|---|
| 1 | -- | 10" Painted Housing (Single Section) |
| -- | 1009879 | f/31' (30'-0" long) |
| 2-4 | -- | 10" Painted Housing, Upper |
| 2 | 1003563 | f/41' & 51' (30'-0" long) |
| -- | 1012441 | f/41' w/Underslung Drive (30'-0" long) |
| 3 | 1009880 | f/61' (30'-0" long) |
| 4 | 1003565 | f/71' (10'-0" long) |
| 5 | -- | 10" Painted Housing, Center |
| -- | 1003567 | f/71' (34'-0" long) |
| 6-11 | -- | 10" Painted Housing, Lower |
| 6 | 1003579 | f/41' (10'-0" long) |
| 7 | 1003680 | f/51' (20'-0" long) |
| -- | 1003581 | f/51' w/Corn Screens /PTO & Elec. Drive (20'-0" long) |
| 9 | 1009883 | f/61' (30'-0" long) |
| -- | 1009884 | f/61' w/Corn Screens f/PTO & Elec. Drive (30'-0" long) |
| 11 | 1003586 | f/71' (26'-0" long) |

PARTS LIST

MAIN AUGER COMPONENTS

AUGER FLIGHT SECTIONS

STANDARD DUTY FLIGHT (7 GA. FLIGHT ON 1.90" O.D. TUBING)

| REF. NO. | PART NO. | DESCRIPTION |
|----------|----------|--|
| 12 | -- | Flight |
| -- | 62712 | f/31' (31'-3" long) |
| 13-14 | -- | Flight, Upper |
| 13 | 62719 | f/41', 51', 57', 61' & 65' (31'-3" long) |
| 14 | 62721 | f/71' (10'-0" long) |
| 15 | -- | Flight, Center |
| -- | 62723 | f/71' (35'-0" long) |
| 16-21 | -- | Flight, Lower |
| 16 | 62716 | f/41' (10'-0" long) |
| 17 | 62720 | f/51' (20'-0" long) |
| 18 | 1009714 | f/57' (26'-0" long) |
| 19 | 1009715 | f/61' (30'-0" long) |
| 20 | 1009716 | f/65' (34'-0" long) |
| 21 | 62715 | f/71' (26'-3" long) |
| -- | 1034461 | f/35' (35'-4" long) |

HEAVY DUTY FLIGHT (1/4" THICK FLIGHT ON 2 3/8" O.D. TUBING)

| REF. NO. | PART NO. | DESCRIPTION |
|----------|----------|---|
| 12 | -- | Flight |
| -- | 1009769 | f/31' (31'-3" long) |
| 13-14 | -- | Flight, Upper |
| 13 | 1009770 | f/41', 51', 57', 61', & 65' (31'-3" long) |
| 14 | 1009771 | f/71' (10'-0" long) |
| 15 | -- | Flight, Center |
| -- | 1009778 | f/71' (35'-0" long) |
| 16-21 | -- | Flight, Lower |
| 16 | 1009772 | f/41' (10'-0" long) |
| 17 | 1009773 | f/51' (20'-0" long) |
| 18 | 1009774 | f/57' (26'-0" long) |
| 19 | 1009775 | f/61' (30'-0" long) |
| 20 | 1009776 | f/65' (34'-0" long) |
| 21 | 1009777 | f/71' (26'-3" long) |
| -- | 1035616 | f/35' (35'-4" long) |

STANDARD DUTY FLIGHT FOR OPTIONAL INTERNAL BEARINGS (7 GA. FLIGHT ON 2-3/8" O.D. TUBING)

| REF. NO. | PART NO. | DESCRIPTION |
|----------|----------|--|
| 22 | -- | Flight, Upper |
| -- | 1004786 | f/31', 41', 51', 57', 61', 65' & 71' (10'-10 1/4" long) |
| 23-25 | -- | Flight, Intermediate |
| 23 | 1011D | f/31', 35', 41', 51', 57', 61', 65' & 71' (9'-9 3/4" long) |
| 24 | 2123C | f/71' (4'-9 3/4" long) |
| 25 | 1009767 | f/71' (6'-9 3/4" long) |
| -- | 1034720 | f/35' (8'-3/4" long) |
| 26-29 | -- | Flight, Lower |
| 26 | 1044D | f/31', 41', 51' & 61' (10'-2" long) |
| 27 | 6116A1 | f/35' & 57' (6'-2" long) |
| 28 | 6024X1 | f/65' (4'-2" long) |
| 29 | 1009768 | f/71' (8'-2" long) |

HEAVY DUTY FLIGHT FOR OPTIONAL INTERNAL BEARINGS (1/4" THICK FLIGHT ON 2-3/8" O.D. TUBING)

| REF. NO. | PART NO. | DESCRIPTION |
|----------|----------|--|
| 22 | -- | Flight, Upper |
| -- | 1009779 | f/31', 35', 41', 51', 57', 61', 65' & 71' (10'-10 1/4" long) |
| 23-25 | -- | Flight, Intermediate |
| 23 | 62449 | f/31', 41', 51', 57', 61', 65' & 71' (9'-9 3/4" long) |
| 24 | 62450 | f/71' (4'-9 3/4" long) |
| 25 | 1009780 | f/71' (6'-9 3/4" long) |
| -- | 1035617 | f/35' (8'-3/4" long) |
| 26-29 | -- | Flight, Lower |
| 26 | 1009784 | f/31', 41', 51' & 61' (10'-2" long) |
| 27 | 1009782 | f/35' & 57' (6'-2" long) |
| 28 | 1009781 | f/65' (4'-2" long) |
| 29 | 1009783 | f/71' (8'-2" long) |

FLIGHT CONNECTING COMPONENTS

FOR STANDARD FLIGHT

| REF. NO. | PART NO. | DESCRIPTION |
|----------|----------|--|
| 30 | 1040240 | Connecting Stub f/ 1.90" O.D. Tubing (weld-in) |
| (30) | 1016240 | Connecting Stub f/ 2 3/8" O.D. Tubing (weld-in) |
| 31 | 1009494 | Bolt 1/2" x 3" long (grade 8) Hex Head Capscrew |
| 32 | 1005127 | Side Depress Lock Nut 1/2" |
| 33 | 1047D | Tail Stub 1-1/2" x 7-3/4" long |

FOR OPTIONAL INTERNAL BEARING FLIGHT

| REF. NO. | PART NO. | DESCRIPTION |
|----------|----------|---|
| 31 | 1009504 | Connecting Bolt 1/2" x 3-1/2" long (grade 8) Hex Head Capscrew |
| 32 | 1005127 | Side Depress Locknut 1/2" |
| 33 | 1047D | Tail Stub 1-1/2" x 7-3/4" long |
| 34 | 1045D | Connecting Stub 1-1/2" x 11-1/2" |
| 35 | 1055D | Internal Bearing Hanger w/Bronze Bushing |
| -- | 1051D | Replacement Bronze Bushing only |
| 36 | 1056D | Inspection Hole Cover (large) |
| 37 | 1042D | Inspection Hole Cover (small) |

PARTS LIST

MAIN AUGER COMPONENTS

DRIVE SHAFT COMPONENTS

| REF. NO. | PART NO. | DESCRIPTION | REF. NO. | PART NO. | DESCRIPTION |
|----------|----------|--|----------|----------|--|
| 38 | 1002443 | Drive Shaft, 1" x 4'-3" lg. f/41' w/PTO Drive | 53 | 6382C | Drive Shaft Brg. (1" Bore) |
| 39 | 1012366 | Drive Shaft, 1" x 6'-7" f/51' w/Elec. Drive | 54 | 54008 | Flangette for Bearing |
| 40 | 1002445 | Drive Shaft, 1" x 8'-2" lg. f/57' w/PTO Drive | 55 | 54584 | Drive Shaft Cover Mounting Clip |
| 41 | 1002446 | Drive Shaft, 1" x 8'-8" lg. f/31' w/PTO Drive | 56 | 1002370 | Band-on Bearing Stand |
| -- | 1034611 | Drive Shaft, 1" x 7'-5" long f/35' units | 57 | 5035A1 | Half Band 2" wide |
| 42 | 1002447 | Drive Shaft, 1" x 9'-6" lg. f/71' w/PTO Drive | 58 | 1002382 | Drive Shaft Coupler (1" to 1") (with Snap Ring) |
| 43 | 1006240 | Drive Shaft, 1" x 9'-9" long f/61' with PTO Drive | 59 | 1002383 | Drive Shaft to Gearbox Coupler (with Snap Ring) (1 1/4" to 1") |
| 44 | 1003203 | Drive Shaft, 1" x 10'-3 1/2" lg f/71' units | 60 | 1002381 | Snap Ring only |
| 45 | 1002450 | Drive Shaft, 1" x 11'-9 1/2" long f/65' w/PTO Drive & 71' units | 61 | 8371C | Square Key 1/4" x 1 1/2" |
| 46 | 1009489 | Drive Shaft, 1" x 12'-3" long f/57' units | 62 | 1002604 | Gearbox Shield Brkt. |
| 47 | 1002453 | Drive Shaft, 1" x 14'-1" long f/71' units and 51' with PTO Drive | 63 | -- | Drive Shaft Covers |
| -- | 1035910 | Drive Shaft, 1" x 15" long f/51' units w/Underslung Drive | -- | 550651 | (5'-8 1/4" long) |
| 48 | 1005243 | Drive Shaft, 1" x 14'-9" long f/61' units | -- | 550650 | (5'-0" long) |
| 49 | 1009493 | Drive Shaft, 1" x 16'-7" long f/65' units | -- | 550649 | (4'-0" long) |
| 50 | 1002454 | Drive Shaft, 1" x 16'-10" long f/31' units | -- | 550648 | (3'-0" long) |
| -- | 1034454 | Drive Shaft, 1" x 22'-5 1/2" long f/35' units | -- | 550647 | (2'-0" long) |
| 51 | 1002455 | Drive Shaft, 1" x 19'-6" long f/71' units | -- | 550645 | (1'-0" long) |
| 52 | 1002457 | Drive Shaft, 1" x 31'-3 1/2" long f/41', 51', 57', 61' & 65' units | -- | 550644 | (0'-8" long) |
| -- | 1002457 | Drive Shaft, 1" x 31'-3 1/2" long f/51' w/Underslung Drive | 64 | -- | Telescoping Drive Shaft Cover (1'-6" long) |
| | | | -- | 550646 | (0'-8" long) |
| | | | 65 | -- | Gearbox (See Drive Components) |
| | | | 66 | 33183 | Sheet Metal Screw |
| | | | 67 | 33020 | Washer 1" O.D. x 1/4" I.D. |
| | | | -- | -- | Enclosed Head Drive (See Page P-4) |

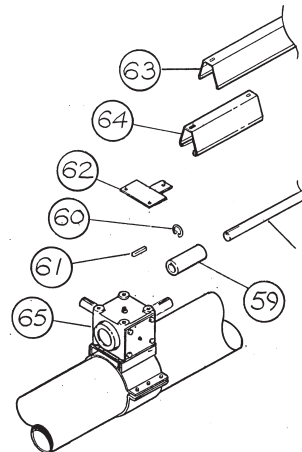
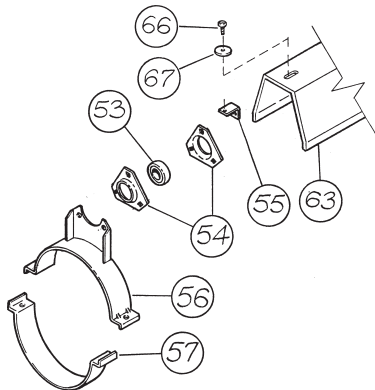

MISCELLANEOUS COMPONENTS

| REF. NO. | PART NO. | DESCRIPTION | REF. NO. | PART NO. | DESCRIPTION |
|----------|----------|----------------------------------|----------|----------|--|
| 68-69 | -- | Connecting Band | 74 | 5044A1 | 4" wide Halfband (f/mounting track) |
| 68 | 1012D | f/51', 57', 61', 65' & 71' | 75 | 6292A1 | 4" wide Halfband w/truss mount f/61' model |
| 69 | 1002719 | f/41' (with undercarriage mount) | 76 | 5930A1 | Halfband f/Intake Guard |
| 70-71 | -- | Band-on Track Extension | 77 | 1024794 | Intake Guard |
| 70 | 1009735 | f/57' & 61' (5'-4" long) | -- | 1051D | Bronze Bushing f/Intake Guard |
| 71 | 1009736 | f/65' (7'-6" long) | 78 | 1008109 | Hitch Pipe |
| 72 | 54548 | Track Connecting Plate | -- | 106445 | Corn Screen Cover 10" |
| 73 | 54330 | Stop f/Undercarriage Track | -- | 106446 | Corn Screen Cover Band 10" |

PARTS LIST

MAIN AUGER COMPONENTS

TOP TRUSS & UNDERTRUSS

| REF. NO. | PART NO. | DESCRIPTION | REF. NO. | PART NO. | DESCRIPTION |
|----------|----------|--|----------|----------|--------------------------------------|
| 1 | 550208 | Top Truss Tube f/41' & 51' | 10 | - - - | Undertruss Cable |
| 2 | 550313 | Cable Clip f/41' & 51' | -- | 1002055 | f/57' (1/4" x 36'-0" long) |
| 3 | 550209 | Side Truss Tube f/41' & 51' | -- | 1002572 | f/61' (1/4" x 40'-0" long) |
| 4 | 12145 | Welded Center Truss Assy. (25" x 34") f/57', 61', 65' & 71' (Includes Ref.16 & 17) | -- | 1003779 | f/65' (1/4" x 42'-0" long) |
| 5 | 12230 | Welded Center Truss (35" x 35") f/65' & 71' (Includes Ref. 17 & 18) | -- | 1002582 | f/71' (5/16" x 46'-0" long) |
| 6 | 12227 | Undertruss Stand-off (Includes Ref. 7) | 11 | 3230A1 | Cable Thimble 1/4" galv. |
| 7 | 6302D | Pulley and Clevis Assembly only (See page P-13 for parts breakdown.) | 12 | 40827 | Cable Thimble 5/16" |
| 8-9 | - - - | Truss Cable, Top | 13 | 6369C | Cable Clamp 1/4" |
| 8 | 1002566 | f/71' (1/4" x 17'-6" long) | 14 | 3153A91 | Cable Clamp 5/16" |
| -- | 1002568 | f/41' (1/4" x 26'-0" long) | 15 | 6308C | Eyebolt 1/2" x 8" (grade 2) (plated) |
| -- | 1002569 | f/51' (1/4" x 31'-6" long) | 16 | 5062B1 | Pin, 3/4" x 10 1/2" |
| -- | 1002570 | f/71' (1/4" x 33'-0" long) | 17 | 3337A1 | Cotter Pin, 3/16" x 1-1/2" |
| -- | 1002055 | f/57' (1/4" x 36'-0" long) | 18 | 54560 | Pin, 3/4" x 14-1/4" |
| -- | 1002572 | f/61' (1/4" x 40'-0" long) | | | |
| -- | 1003779 | f/65' (1/4" x 42'-0" long) | | | |
| 9 | 1002581 | f/71' (5/16" x 17'-6" long) | | | |

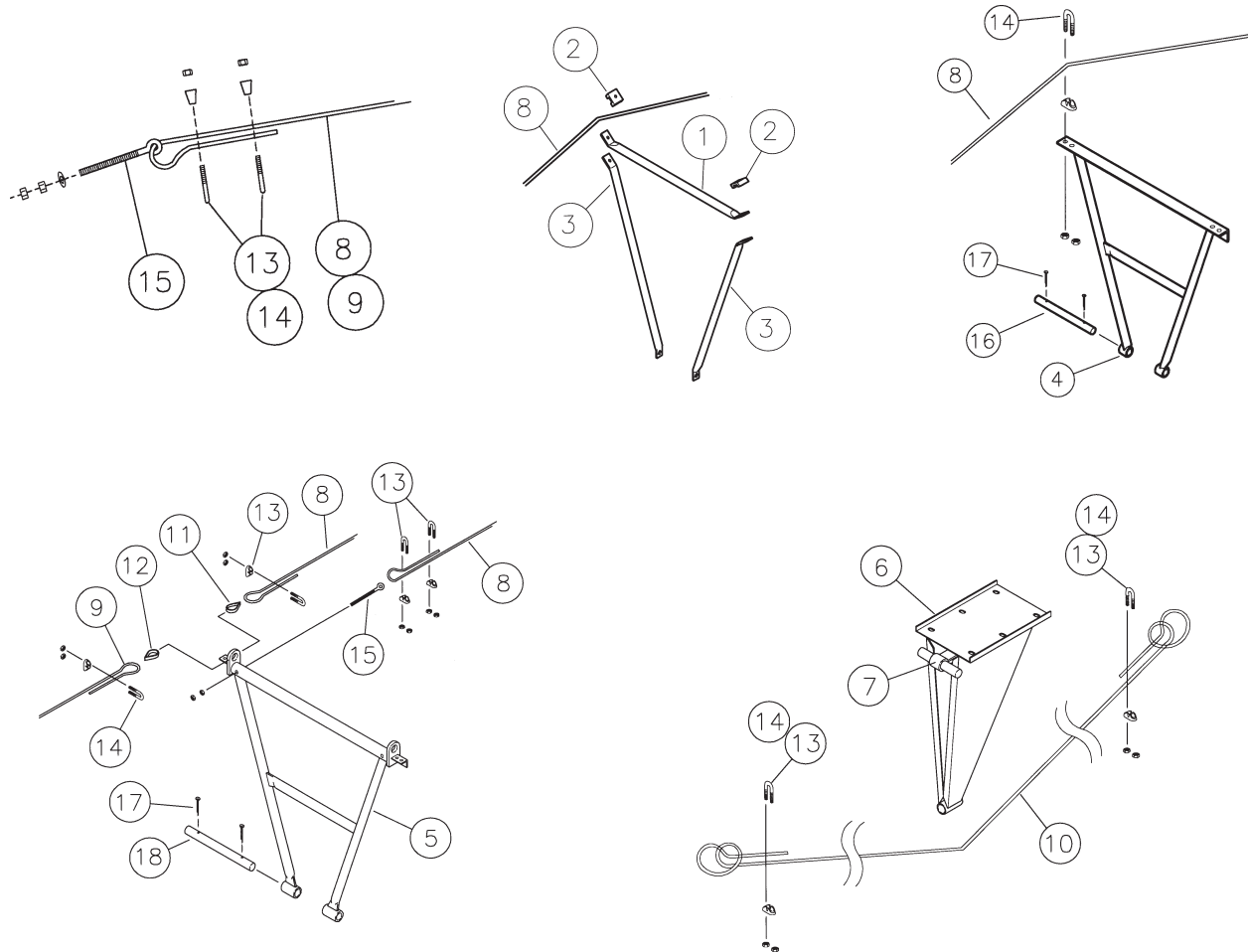

PARTS LIST

UNDERCARRIAGE COMPONENTS

| REF. NO. | PART NO. | DESCRIPTION | REF. NO. | PART NO. | DESCRIPTION |
|----------|----------|---|----------|----------|--|
| 1 | -- | Undercarriage with Slide Assembly | 11 | --- | Winch Cable |
| -- | 1008474 | f/31' | -- | 1002570 | f/31' (1/4" x 33'-0" long) |
| -- | 1034336 | f/35' | -- | 1002573 | f/41' (1/4" x 44'-0" long) |
| -- | 1002498 | f/41' | -- | 1002576 | f/51' (1/4" x 75'-0" long) |
| -- | 1002499 | f/51' | -- | 8396C | f/57' (1/4" x 82'-0" long) |
| -- | 1035901 | f/51' w/Underslung Drive | -- | 1002578 | f/61' (1/4" x 93'-0" long) |
| -- | 1009676 | f/57' | -- | 1002579 | f/65' (1/4" x 98'-0" long) |
| -- | 1002500 | f/61' & 65' | -- | 1002580 | f/71' (1/4" x 115'-0" long) |
| 2 | 1002501 | Undercarriage with Slide Assembly f/71' | 12 | 6369C | Cable Clamp 1/4" |
| 3 | 8387D | Undercarriage Mount Clamp f/31', 41' & 51' | 13 | --- | Winch (See pages P-14 for parts breakdown.) |
| 4 | 6002A1 | Undercarriage Mount Clamp f/57', 61' & 65' | -- | 3335A11 | f/31', 41', 51' & 57' |
| 5-10 | 6302D | Pulley & Clevis Assy. | -- | 40301 | f/61', 65' & 71' |
| 5 | 50079A1 | Cable Pulley Bushing | 14 | --- | Spindle and Hub Assembly (See page P-15 for parts breakdown.) |
| 6 | 5120A1 | Pulley Clevis | -- | 1001563 | f/31', 41' & 51' |
| 7 | 3223A1 | 1/4" Cable Pulley (1 1/16" I.D. x 3" O.D.) | -- | 1003104 | f/57', 61', 65' & 71' |
| 8 | --- | Cotter Pin 1/4" x 2" long | -- | --- | Wheel Rim |
| 9 | --- | 1/2" x 2" Hex Head Capscrew Grade 5 | | 6393D | 15" x 4.5 KB 4-Bolt f/31', 41' & 51' |
| 10 | --- | 1/2" Nylock Nut | | 107225 | 15" x 6 LB 5-Bolt f/57', 61', 65' & 71' |

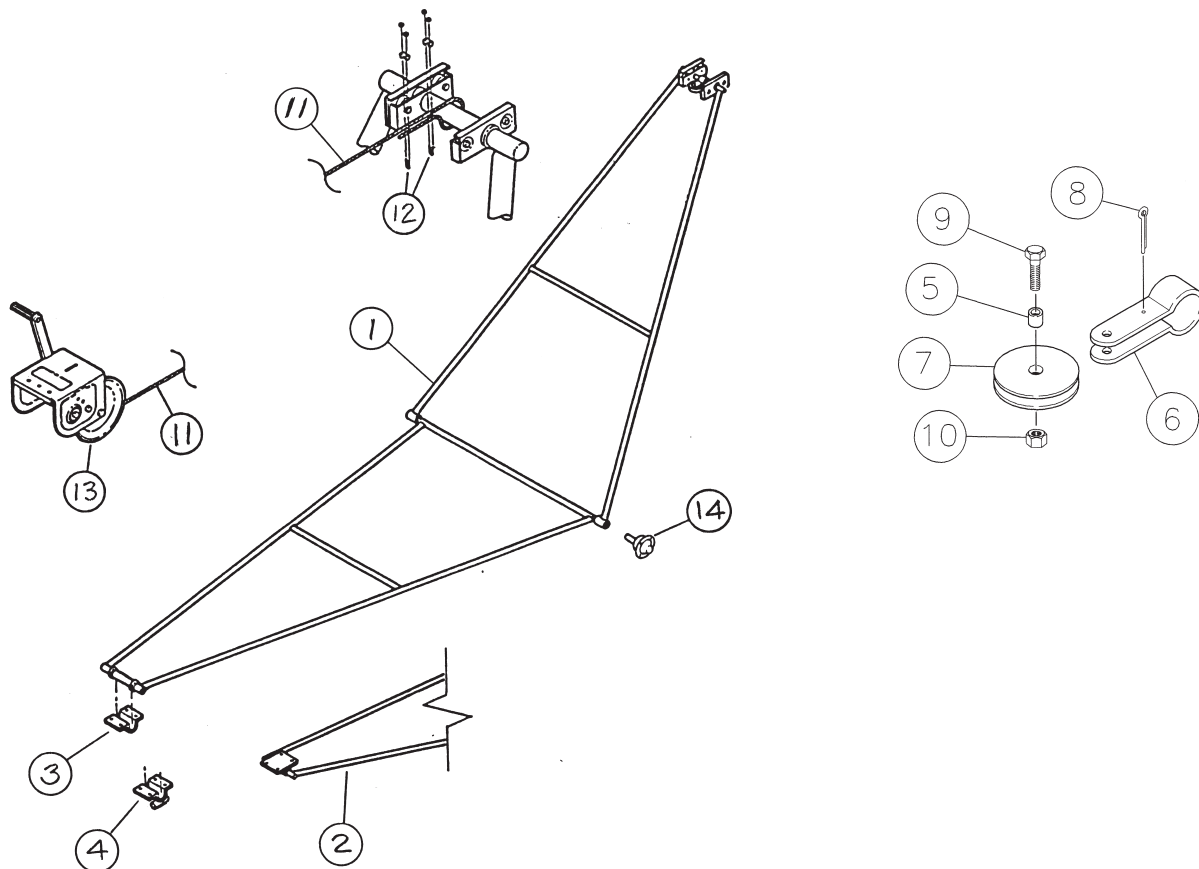

PARTS LIST

UNDERCARRIAGE COMPONENTS

COMPLETE WINCH - PART NUMBER 3335A11 FULTON MODEL K-1550 WINCH USED ON 31', 41', 51' & 57' MODELS

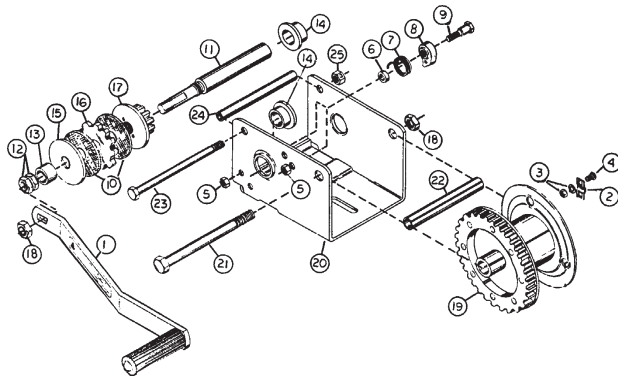

NOTE: Repair parts for winch can also be purchased directly from:
Fulton Manufacturing Corp.
P.O. Box 19903
Milwaukee, WI 53219

*Indicates standard hardware items - purchase locally.

**These items are not available as separate parts because of the precision assembly required. If these parts require replacement, a new winch unit is recommended.

| REF NO. | DESCRIPTION | HUTCHINSON/ | |
|---------|--------------------------------------|---------------------|--------------------|
| | | MAYRATH PART NO. | FULTON PART NO. |
| 1 | Handle Assembly | 41595 | 2461S01 |
| 2 | Cable Clamp | | |
| 3 | Lock Washer & Nut | Cable Keeper | Cable Keeper |
| 4 | Carriage Bolt | Kit 41600 | Kit 5621S01 |
| 5 | Lock Nut 5/16" - 18 Hex | | |
| 6 | Ratchet Spacer | Ratchet Kit | Ratchet Kit |
| 7 | Ratchet Spring | 40836 | 6730S00 |
| 8 | Ratchet Pawl | | |
| 9 | Hex Head Shoulder Bolt 5/16" - 18 | | |
| 10 | Brake Disc Kit | 41596 | 1558S00 |
| 11 | Input Shaft | | |
| 12 | Lock Nut 1/2" - 13 Hex | | |
| 13 | Spacer | Input Shaft | Input Shaft |
| 14 | Bushing | Kit | Kit |
| 15 | Shaft Brake Disc | 41597 | 1563S01 |
| 16 | Ratchet Gear | | |
| 17 | Pinion & Disc Assembly | | |
| 18 | Hex Lock Nut 1/2" - 13 | * | * |
| 19 | Drum Assembly | ** | ** |
| 20 | Frame | ** | ** |
| 21 | Hex Head Capscrew 1/2" - 13 - 5 3/4" | * | * |
| 22 | Drum Spacer | ** | ** |
| 23 | Hex Head Capscrew 3/8" - 16 - 5 3/4" | * | * |
| 24 | Frame Spacer | ** | ** |
| 25 | Hex Lock Nut 3/8" - 18 | * | * |
| 26 | Handle Label | 2169A1 | ** |

WINCH - BRAKE TYPE

COMPLETE WINCH - PART NUMBER 40301 FULTON MODEL K-2550 WINCH USED ON 61', 65' & 71' AUGERS

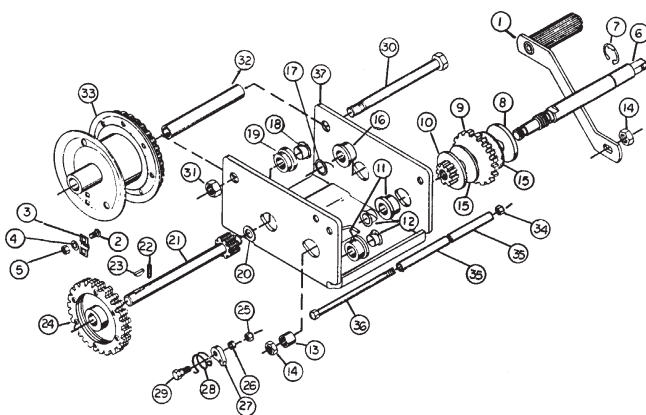

NOTE: Repair parts for winch can also be purchased directly from:
Fulton Manufacturing Corp.
P.O. Box 19903
Milwaukee, WI 53219

| REF NO. | DESCRIPTION | HUTCHINSON/ | |
|---------|---------------------|---------------------|--------------------|
| | | MAYRATH PART NO. | FULTON PART NO. |
| 1 | Handle | 41595 | 2461S01 |
| 2 | Bolt | Cable Keeper | CableKeeper |
| 3 | Cable Clamp | Kit | Kit |
| 4 | Lockwasher | 41600 | 5621S01 |
| 5 | Nut | | |
| 6 | Input Shaft | | |
| 7 | Retaining Ring | | |
| 8 | Brake Disc | Input Shaft | Input Shaft |
| 9 | Ratchet Gear | Kit | Kit |
| 10 | Pinion Gear | 41598 | 1565S01 |
| 11 | Bushing | | |
| 12 | Insert | | |
| 13 | Spacer | | |
| 14 | Nut | | |
| 15 | Friction Disc | 41601 | Kit 1578S00 |
| 16 | Bushing | | |
| 17 | Insert | | |
| 18 | Insert | | |
| 19 | Bushing | Intermediate | Intermediate |
| 20 | Washer | Shaft | Shaft |
| 21 | Intermediate Shaft | Kit | Kit |
| 22 | Roll Pin | 41599 | 1569S01 |
| 23 | Woodruff Key | | |
| 24 | Gear | | |
| 25 | Nut | | |
| 26 | Spacer | Ratchet Kit | Ratchet Kit |
| 27 | Ratchet Pawl | 40836 | 6730S00 |
| 28 | Spring | | |
| 29 | Shoulder Bolt | | |
| 30 | Drum Bolt T-Grade 5 | * | * |
| 31 | Locknut | * | * |
| 32 | Drum Spacer | ** | ** |
| 33 | Drum Assembly | ** | ** |
| 34 | Locknut | * | * |
| 35 | Frame Spacer | ** | ** |
| 36 | Bolt | * | * |
| 37 | Frame | ** | ** |

UNDERCARRIAGE COMPONENTS

SPINDLE & HUB ASSEMBLIES

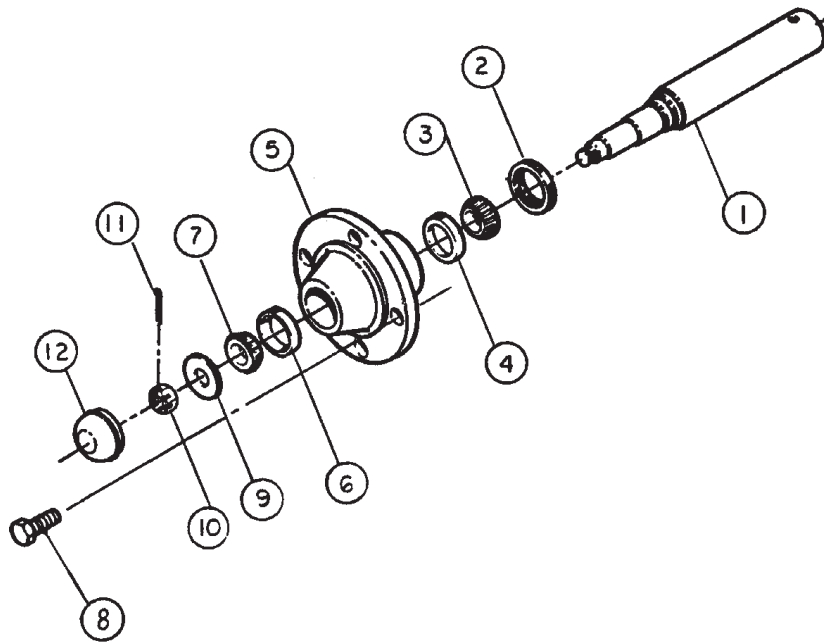

| REFNO. | DESCRIPTION | 4-BOLT | 5-BOLT |
|--------|----------------------------|--------------------------------------|---|
| | | (2 1/16" x 10") f/31', 41', & 51' | (2 3/8" x 14") f/57', 61', 65' & 71' |
| -- | Spindle & Hub Assy. | 1001563 | 1003104 |
| 1 | Spindle | 1001002 | 1001004 |
| 2 | Grease Seal | 106245 | 107233 |
| 3 | Inner Cone (Timken No.) | 3079R1 (LM67048) | 3078R1 (LM48548) |
| 4 | Inner Cup (Timken No.) | 3148R1 (LM67010) | 3147R1 (LM48510) |
| 5 | Hub | *90174 | *1006987 |
| 6 | Outer Cup (Timken No.) | 40552 (LM11910) | 3148R1 (LM67010) |
| 7 | Outer Cone (Timken No.) | 40551 (LM11949) | 3079R1 (LM67048) |
| 8 | Lug Bolt | 106241 | -- |
| 8 | Lug Nut | -- | 107235 |
| 9 | Washer | 106252 | 107229 |
| 10 | Slotted Hex Nut | 106250 (5/8") | 6360C (3/4") |
| 11 | Cotter Pin | D1146 | 107230 |
| 12 | Hub Cap | (5/32" x 1 1/4") 106244 | (5/32" x 1 3/4") 107234 |

* Furnished with Cups Only.

PARTS LIST

DIRECT PTO DRIVE COMPONENTS

| REF. NO. | PART NO. | DESCRIPTION |
|----------|----------|---|
| 1 | 1002172 | PTO Driveline (See page P-17 for parts breakdown.) |
| 2 | 862113 | PTO to Gearbox Shield |
| 3 | 1006130 | Gearbox (See page P-18 for parts breakdown.) |
| 4 | 103245 | Gearbox Mount |
| 5 | 1009823 | Halfband w/Manual Container Brkt. |
| 6 | 8371C | Square Key 1/4" x 1 1/2" long |
| 7 | 6835A1 | PTO Driveline Support |
| 8 | 3338A1 | Driveline Support Pin |
| 9 | 5035A1 | Halfband |

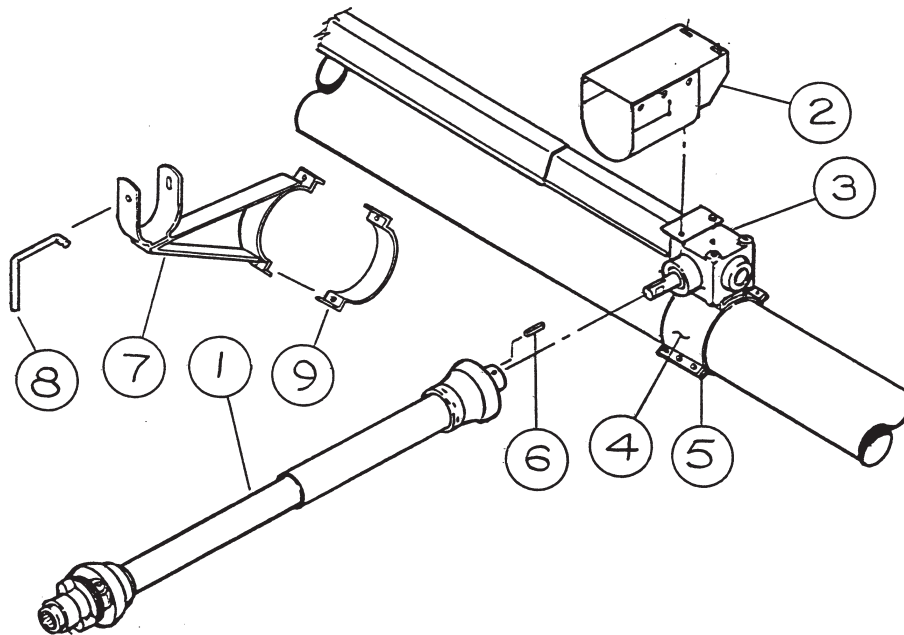

PTO DRIVELINE COMPONENTS

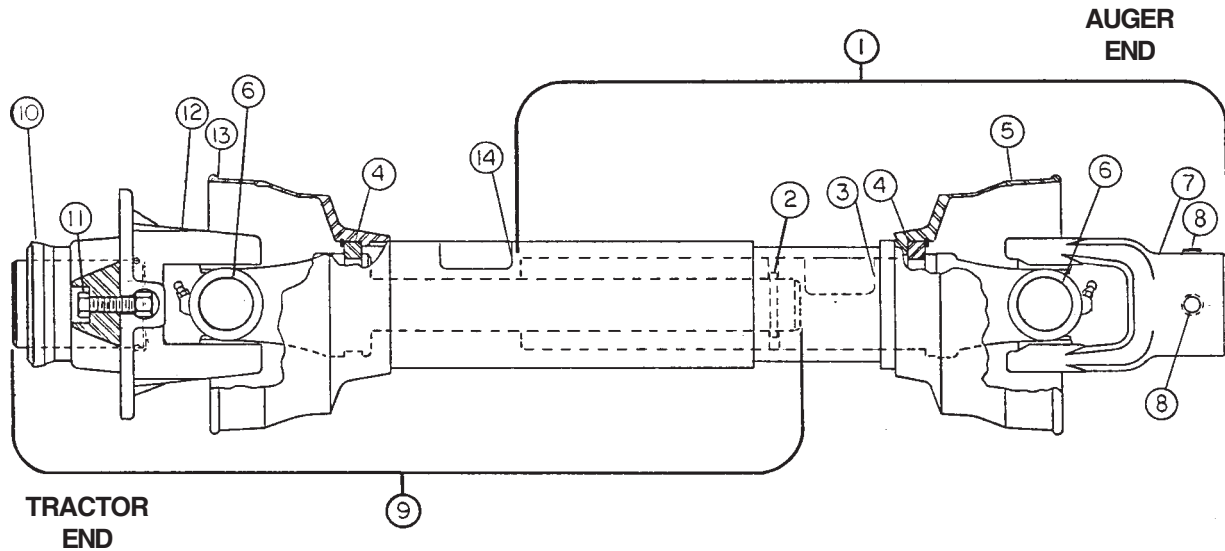

NOTE: Repair parts for PTO drivelines can also be purchased directly from:

**Weasler Engineering, Inc.
P.O. Box 558
West Bend, WI 53095**

**U-JOINT TYPE - 14R
AUGER END 1 1/4" BORE
WITH 1/4" KEYSEAT
TRACTOR END 1 3/8 - 6B SPLINE
WITH SHEAR BOLT**

| REF. NO | DESCRIPTION | HUTCHINSON/ MAYRATH PART NO. | WEASLER PART NO. |
|---------|--|------------------------------------|---------------------|
| -- | PTO Driveline Complete | 1002172 | 232-16106 |
| 1 | Joint & Tube Half Assembly with Guard (Auger End) | 1015285 | 92-16106 |
| 2 | Roll Pin 1/4" x 1" long | 1003691 | 11-10454 |
| 3 | Inner Safety Sign | 13-10022 | 13-10022 |
| 4 | Shield Nylon Bearing Kit | 1010565 | 19-11104 |
| 5 | (Includes Ref. No. 4) | | |
| 6 | U-Joint Cross Repair Kit | 40524 | 03-10134 |
| 7 | End Yoke | 1003683 | 14011-1117 |
| 8 | .375 - 16 x .38 long Setscrew | 33170 | 11-10215 |
| 9 | Joint & Shaft Half Assembly with Guard (Tractor End) | 1015286 | 93-16106 |
| 10 | Spring Lock Flange Repair Kit | 1003674 | 26-10133 |
| 11 | Shear Bolt & Nut Kit (See Note) | 1004778 | -- |
| 12 | Yoke & Ball Shear Assembly | 1006480 | 26-11670 |
| 13 | Outer Guard | 1006481 | 97-16106 |
| | (Includes Ref. No. 4) | | |
| 14 | Outer Safety Sign | 13-10021 | 13-1002 |

Note: Shear Bolt Kit includes (6) 5/16" - 18 x 1" long Grade 5 hex bolts and locknuts.

PARTS LIST

GEARBOX COMPONENTS

COMPLETE PART NO. 1006130-1
 FOR UNITS WITH PTO OR ELECTRIC DRIVE
 1 1/4" DIA. INPUT SHAFT - 1 1/4" DIA. OUTPUT SHAFT
 3/8" MOUNTING HOLES - 4" SQUARE MOUNTING PATTERN
 RATIO 1 TO 1

This gearbox is purchased from Weasler.
 The word "CHINA" will be inscribed
 on the housing.

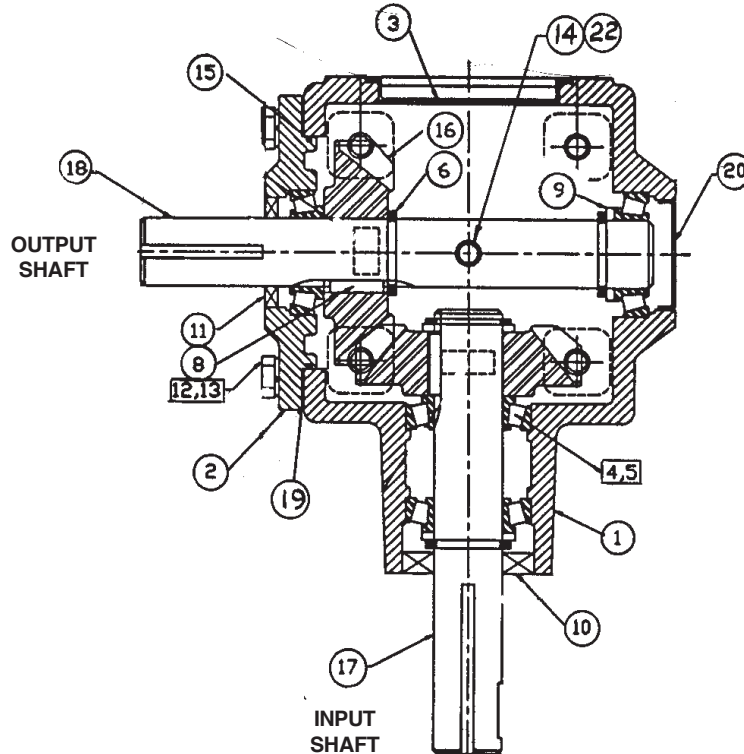

| REF. NO. | QTY. REQ'D. | PART NO. | DESCRIPTION |
|----------|-------------|----------|----------------------------|
| 1 | 1 | N/A | Case |
| 2 | 1 | N/A | End Cap |
| 3 | 1 | N/A | Large Cover |
| 4 | 4 | 3079R1 | Brg. Cone (LM67048) |
| 5 | 4 | 3148R1 | Brg. Cup (LM67010) |
| 6 | 4 | 003538 | Snap Ring |
| 8 | 2 | 020153 | Square Key 1/4" x 7/8" lg. |
| 9 | 3 | 1023533 | Spacer |
| 10 | 1 | 1023278 | Seal (Nat. #471808). |
| 11 | 1 | 1023279 | Seal (Nat. #470163) |
| 12 | 4 | 33060 | 3/8" x 1" NC Capscrew |
| 13 | 4 | D1150 | 3/8" Lockwasher |
| 14 | 1 | 020009 | 1/4" Pipe Plug |
| 16 | 2 | N/A | Gear 90° Bevel - 17 tooth |
| 17 | 1 | N/A | Input Shaft |
| 18 | 1 | N/A | Output Shaft |
| 19 | A/R | 1023288 | Shim Kit |
| 20 | 1 | 1023577 | Small Cover |
| 22 | 1 | 035916 | 1/4" Vented Plug |

PARTS LIST

TOP MOUNTED ELECTRIC DRIVE COMPONENTS

| REF. NO. | PART NO. | DESCRIPTION | REF. NO. | PART NO. | DESCRIPTION |
|----------|----------|---|----------|----------|---|
| 1 | 1006130 | Gearbox (See page P-18 for parts breakdown.) | 8 | --- | Sheave |
| 2 | 103245 | Gearbox Mount | -- | 40161 | Aluminum 3B 15" - 1 1/4" Bore f/31', 41' & 51' |
| 3 | 1009823 | Half Band w/Bracket f/ Manual Container | -- | 3092A1 | QD 4B 15.4" P.D. f/57', 61', 65' & 71' |
| 4 | 1039198 | Motor Mount Frame | -- | 3085A1 | QD SF Bushing 1-1/4" Bore |
| 5 | 106207-1 | Half Band for Motor Mount Frame | 9 | -- | Belt |
| 6 | 1002774 | Belt Guard Mount Bracket | -- | 40122 | B-62 f/31', 41' & 51' |
| 7 | 1039204 | Belt Guard | -- | 40124 | B-66 f/57', 61', 65' & 71' |
| | | | 10 | 4046A1 | Square Key 1/4" x 3" |
| | | | 11 | 1004287 | Manual Container w/Caps |
| | | | -- | 1004744 | Cap f/Manual Container |

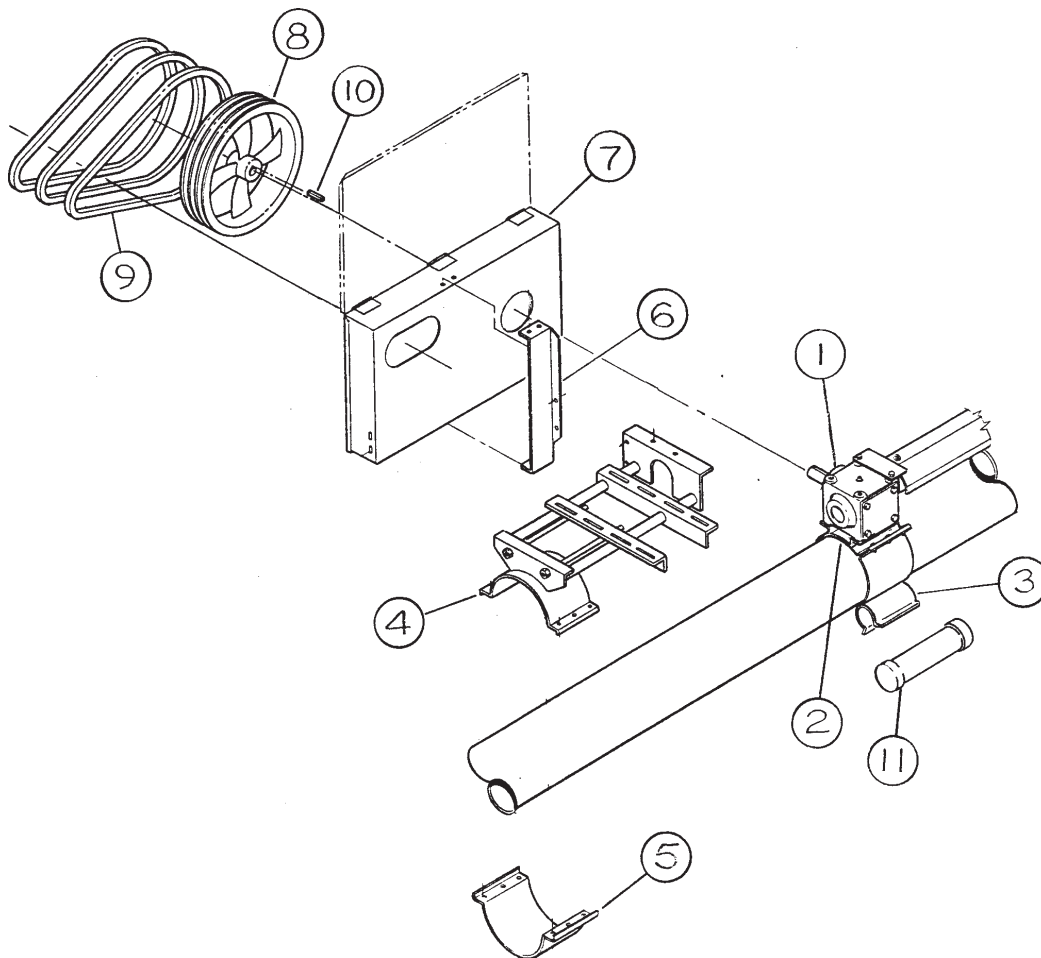

PARTS LIST

UNDERSLUNG GAS ENGINE DRIVE COMPONENTS

| REF. NO. | PART NO. | DESCRIPTION |
|----------|-----------|---|
| 1 | 1029210-1 | Gearbox w/Pivot Ears (1-1/2 to 1 Ratio) (See page P-21 for parts breakdown.) |
| 2 | 1031444 | Band-on Gearbox Mount |
| 3 | 106225 | Half Band (6" wide) |
| 4 | 1031447 | Underslung Frame |
| 5 | 1031436 | Pivot Clamp |
| 6 | 1031480 | Pivot Clamp with Belt Guard Bracket |
| 7 | -- | Adjustment Strap |
| | 1009406 | f/31' (13-3/8" long) |
| | 1009543 | f/41' & 51' (16-1/2" long) |
| 8 | 1005023 | Large Belt Guard |
| 9 | 1005051 | Belt Guard Ring |
| 10 | 1005126 | Small Belt Guard |
| 11 | 40133 | B-100 Belt |
| 12 | 40158 | Sheave 15" 2B 1 1/4" Bore |
| -- | 1009823 | Halfband w/Manual Container Bracket |
| -- | 1004287 | Manual Container w/Caps |
| -- | 1004744 | Cap f/Manual Container |

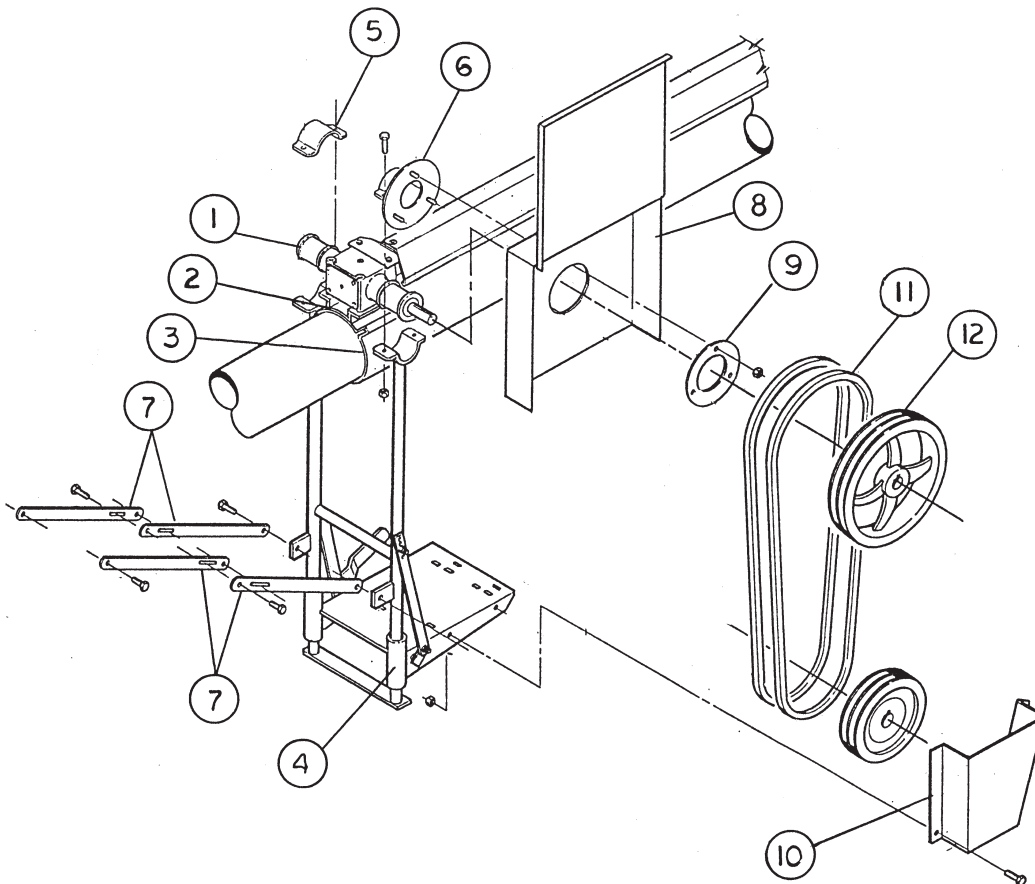

PARTS LIST

GEARBOX COMPONENTS COMPLETE PART NO. 1029210-1

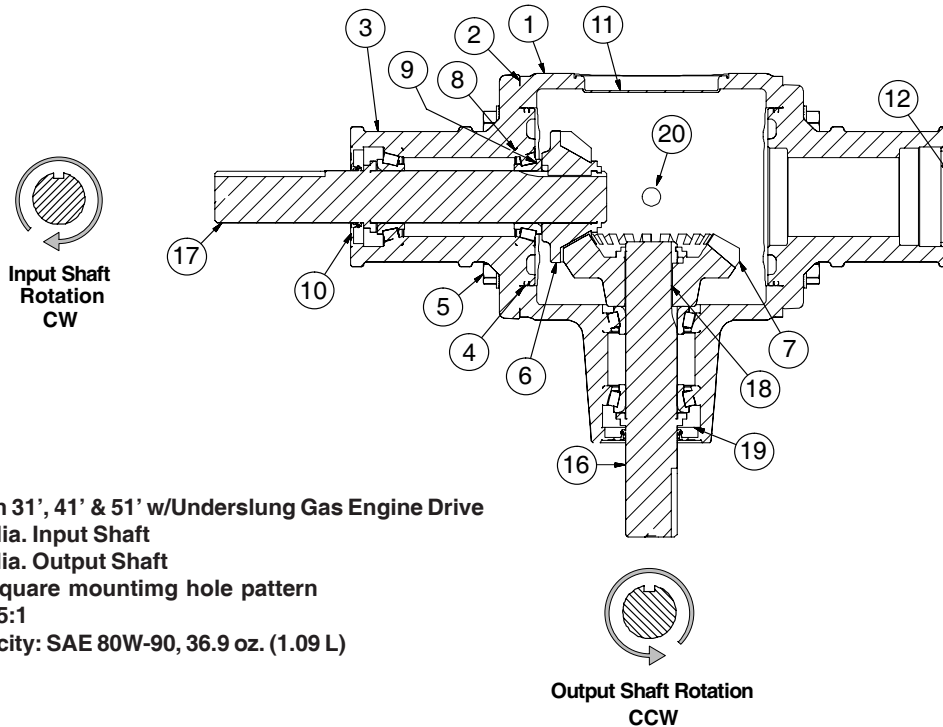

Used on 31', 41' & 51' w/Underslung Gas Engine Drive
 1-1/4" dia. Input Shaft
 1-1/4" dia. Output Shaft
 4.50" Square mounting hole pattern
 Ratio 1.5:1
 Oil Capacity: SAE 80W-90, 36.9 oz. (1.09 L)

| Ref. No. | Part No. | Description | Qty |
|----------|-----------|--------------------------------|-----|
| 1 | 70-06128 | Housing | 1 |
| 2 | 19-15204 | Gasket Kitl | 1 |
| 3 | 70-26051 | Bearing Housing | 2 |
| 4 | 28-21003 | O-Ring | 2 |
| 5 | 11-20442 | Screw, 3/8-16 x 1" G5 | 8 |
| 6 | 71-06095 | Gear, 14 tooth/ M = 5.25 | 1 |
| 7 | 71-06096 | Gear, 21 tooth/ M = 5.25 | 1 |
| 8 | 12-20110 | Bearing Cup (LM67010) | 4 |
| 9 | 12-20111 | Bearing Cone (LM67048) | 4 |
| 10 | 28-11005 | Seal 1.25 x 2.375 x 0.315 | 2 |
| 11 | 11-81037 | Stamping cover | 1 |
| 12 | 28-11026 | Seal (60 x 7) | 1 |
| 13 | 19-15207* | Shim Kit | 1 |
| 14 | 11-40541* | Spacer | 4 |
| 15 | 24-15250* | Retaining Ring | 2 |
| 16 | 09-70133 | Shaft | 1 |
| 17 | 09-70134 | Shaft | 1 |
| 18 | 11-61019 | Key, 1/4" x 1.1" sq. | 2 |
| 19 | 24-15251 | Retaining Ring | 2 |
| 20 | 11-81029 | Plug, pipe, 1/4-18 NPT | 2 |
| 21 | 11-81035* | Plug, Vent, 1/4 NPT | 1 |

* Not Shown



Hutchinson/Mayrath

A Division of GLOBAL Industries Inc.

Hutchinson/Mayrath • P.O. Box 629 • Clay Center, KS. 67432
Ph. 785-632-2161 • Fx. 785-632-5964 • Toll Free 800-523-6993