

12" IN-LINE / MID DRIVE PORTABLE AUGER

OWNER'S & OPERATOR'S MANUAL

Effective December 18, 2007

Publication No. 1016179

THIS MANUAL IS FOR UNITS WITH SERIAL NUMBERS OF 921756 OR HIGHER.



Hutchinson/Mayrath

A Division of **GLOBAL** Industries, Inc.

P.O. Box 629 • 514 W. Crawford • Clay Center, KS 67432
Phone 785-632-2161 • 1-800-523-6993 • FAX 785-632-5964



Hutchinson/Mayrath

A Division of **GLOBAL Industries, Inc.**

POLICIES AND PROCEDURES

- PRICES:** Prices in effect at time of shipment will apply. Prices are subject to change without notice. All prices are F.O.B. Clay Center, Kansas. Orders shipped from locations other than Clay Center, Kansas will be subject to additional charges, such as back freight and/or additional freight.
- SERVICE CHARGE:** A service charge will be assessed on all past due balances as permitted by state law not to exceed 1-1/2% per month.
- MINIMUM ORDER:** Processing and handling costs necessitate a minimum charge of \$15.00 net on all orders.
- BACK ORDERS:** Back orders will be shipped as they become available. Contact Hutchinson/Mayrath Customer Service for alternative shipping options or if cancellation is desired.
- DAMAGED GOODS:** It is the consignee's responsibility to check all shipments thoroughly upon receipt of goods. If any damage is discovered, it must be noted on the freight bill of lading before signing. The consignee must make necessary claims against the respective freight line. All damage claims must be submitted within 30 days of delivery receipt.
- SHORTAGES:** All shortages must be noted at time of delivery receipt. Shortages must be noted on the freight bill of lading before signing. Hutchinson/Mayrath must be advised of all concealed shortages upon discovery. Once notified of concealed shortages Hutchinson/Mayrath will advise corrective action to be taken.
- RETURN OF GOODS:** All returns must be approved by Hutchinson/Mayrath prior to shipment. All return requests will be issued a return authorization number. **NO RETURNS WILL BE ACCEPTED WITHOUT A RETURN AUTHORIZATION NUMBER AND PRIOR AUTHORIZATION FROM THE FACTORY.** All returns must be shipped prepaid. A 15% restocking charge will be applied to all returned merchandise. Custom Products may not be returned for credit. Only current products in new and salable condition may be returned. No safety devices may be returned for credit.
- MODIFICATIONS:** It is the policy of Hutchinson/Mayrath to improve its product whenever possible and practical to do so. We reserve the right to make changes, improvements and modifications at any time without incurring the obligation to make such changes, improvements and modifications on any equipment sold previously.
- LIMITED WARRANTY:**
- (a) For a period of (1) year after receipt of goods by the original consumer buyer, Hutchinson/Mayrath will supply free of charge replacement parts for parts that prove defective in workmanship or material. Defective parts must be returned freight prepaid to a specified Hutchinson/Mayrath location. Only Hutchinson/Mayrath original repair parts may be used for warranty repairs.
 - (b) This limited warranty does not extend to parts designed to wear in normal operation and be replaced periodically; or to damage caused by negligence, accident, abuse or improper installation or operation.
 - (c) **GOODS NOT MANUFACTURED BY HUTCHINSON/MAYRATH CARRY ONLY THE MANUFACTURER'S WARRANTY.**
 - (d) **THIS UNDERTAKING IS IN LIEU OF ALL OTHER WARRANTIES, EXPRESSED OR IMPLIED, INCLUDING MERCHANTABILITY AND FITNESS FOR A PARTICULAR PURPOSE.**
- FAILURE TO FOLLOW THE INSTRUCTIONS CONTAINED IN THE OWNER'S & OPERATOR'S MANUALS AND THE ITEMS LISTED BELOW WILL RESULT IN THE VOIDING OF THIS LIMITED WARRANTY.**
- 1) Improper assembly, including failure to properly install all safety equipment.
 - 2) Improper installation (power & wiring included).
 - 3) Unauthorized alterations of goods.
 - 4) Goods operated when obviously in need of repair.
 - 5) Use of unauthorized repair parts.
 - 6) Irresponsible operation.
 - 7) Used to handle materials other than free flowing, non-abrasive and dry materials, as intended.
 - 8) Damaged through abusive use or accident.
- LIMITATION OF LIABILITY:** BUYER AGREES THAT IN NO EVENT SHALL HUTCHINSON/MAYRATH HAVE LIABILITY FOR DIRECT DAMAGES IN EXCESS OF THE CONTRACT PRICE OF THE GOODS IN RESPECT OF WHICH CLAIM IS MADE. BUYER FURTHER AGREES THAT IN NO EVENT SHALL HUTCHINSON/MAYRATH ON ANY CLAIM OF ANY KIND HAVE LIABILITY FOR LOSS OF USE, LOSS OF PROFITS, OR FOR ANY INDIRECT, INCIDENTAL OR CONSEQUENTIAL DAMAGES.

GENERAL SAFETY STATEMENT

This manual was written with the safety of the operator and others who work with the equipment as our prime concern. The instructions presented will help the reader learn SAFE day to day work practices. We want you as our partner in safety.

It is your responsibility as an owner, operator or supervisor to know what specific safety requirements and precautions exist and to make these known to all other personnel working with the equipment or in the area, so that they too may safely perform their duties and avoid any potentially hazardous situations.

Please remember safety equipment provides important protection for persons around a grain handling system that is in operation. Be sure that ALL safety shields and protection devices are installed and properly maintained. If any shields or guards are damaged or missing, contact your dealer to obtain the correct items.

Avoid any alterations of the equipment. Such alterations may create a dangerous situation where serious injury or death may occur.

SAFETY ALERT SYMBOL

The symbol shown below is used to call your attention to instructions concerning your personal safety. Watch this symbol - it points out important safety precautions. It means "ATTENTION! Become alert! Your personal safety is involved!" Read the message that follows and be alert to the possibility of personal injury or death.



BE ALERT! YOUR SAFETY IS INVOLVED.



WARNING

Anyone who will operate or work around this machine shall first read this manual! This manual must be delivered with the equipment to its owner. Failure to read this manual and its safety instructions is a misuse of the equipment.

TABLE OF CONTENTS

General Safety Statement	1
Safety Symbol	1
Operator Qualifications	3
Sign-off Sheet	3
Machine Inspection	3
TRACTOR REQUIREMENTS	4
HITCHING TO TRACTOR	4-5
TRANSPORTING THE AUGER	6
Transport Heights	6
PLACEMENT OF AUGER	7-8
UN-HITCHING	8
DESIGNATED WORK AREA	9-10
Work Area Diagram	9
Rules for Safe Work Area	10
OPERATING PROCEDURES	10-15
General Operation	10
Break-in Information	11
Direct PTO Drive Information	11-12
Top Mounted Electric Motor Drive Information	13
Shutdown	14
Lockout	14
Operating Capacities	14
RELOCATION OF AUGER	15
LUBRICATION AND MAINTENANCE	16-18
TROUBLE SHOOTING	19
ASSEMBLY INSTRUCTIONS	20-41
Housing Layout	20
Flight, Gearbox & Housing	20-23
Truss	24-27
Undercarriage	28-34
Hydraulic Components	35-36
Hitch Jack	37
Drain Hole Cover	38
Hitch	38
Blow-Off Cap	38
Drives	39-41
PTO DRIVE CHANGEOVER	42
DRIVE HOUSING DISASSEMBLY	42
NOTICE TO DEALER / ASSEMBLER	43
PARTS LIST	P-1 thru P-15

SERIAL NUMBER

To ensure efficient and prompt service, please furnish us with the model and serial number of your auger in all correspondence or other contact. The serial plate is located on the left side of the drive housing on the tube.

RIGHT AND LEFT DESIGNATION

When determining which is the left or right hand side of the unit, it is as if a person were standing at the intake end and looking toward the discharge end.

OPERATOR QUALIFICATIONS

Operation of this portable auger shall be limited to competent and experienced persons. In addition, anyone who will operate or work around a portable auger must use good common sense. In order to be qualified, they must also know and meet all other requirements, such as:

1. Some regulations specify that no one under the age of 16 may operate power machinery. This includes portable augers. It is your responsibility to know what these regulations are in your own area or situation.
2. Current OSHA regulations state in part: "At the time of initial assignment and at least annually thereafter, the employer shall instruct every employee in the safe operation and servicing of all equipment with which the employee is, or will be involved."*
3. Unqualified persons are to stay out of the work area as shown in the work area diagrams. See Page 9.
4. A person who has not read and understood all operating and safety instruction is not qualified to operate the machine.

*Federal Occupational Safety & Health Standards for Agriculture Subpart D, Section 1928.57 (a)(6).

SIGN OFF SHEET

As a requirement of OSHA it is necessary for the employer to train the employee in the safe operation and handling of this auger. We include this sign off sheet for your convenience and personal record keeping.

DATE	EMPLOYER SIGNATURE	EMPLOYEE SIGNATURE

MACHINE INSPECTION

After delivery of your new auger and/or completion of assembly and before each use, inspection of the machine is mandatory. Use the assembly instructions in this manual as a reference to determine that the auger is assembled properly. This inspection should include, but not be limited to:

1. Check to see that all guards listed in the assembly instructions are in place, secured and functional.
The shields on the PTO driveline must rotate easily.
2. Check all safety signs and replace any that are worn, missing or illegible. The safety signs are listed in the back of this manual. Safety signs may be obtained from your dealer or ordered from the factory.
3. On 32' & 42' Models - Check undercarriage winch and cable for security and operation. There should be at least three complete wraps of cable around winch drum in full down position. Cable anchor on winch drum must be tight.
On 62', 72' & 82' Models - Check all hydraulic hoses, tubing and fittings to see if they are tight and not leaking hydraulic oil.
4. Are all fasteners tight?
5. Are belts properly adjusted? (See Maintenance Section.)
6. Check oil level in gearbox. (See Maintenance Section.)

Obtain any needed replacement parts from your dealer and install before using the machine.

TRACTOR REQUIREMENTS

This 12" auger was designed to use a tractor with the following specifications:

1. 540 RPM Power Take Off
2. One hydraulic control circuit for lifting the main auger. (See chart for minimum pressure.)

	12" x 32'	12" x 42'	12" x 62'	12" x 72'	12" x 82'
Tractor Hydraulic for Auger Lift	Unneeded	Unneeded	1500 PSI	1500 PSI	1500 PSI
Approximate PTO Horsepower	50	60	80	90	100

HITCHING TO TRACTOR INSTRUCTIONS

1. A hitch jack is provided to lift the intake for hitching and unhitching purposes. The jack should be positioned approximately vertical to the ground. To adjust this, remove the bolt connecting the support tube to the mount tube, align the appropriate holes, and securely replace the bolt and nut. See Fig. 1. Crank the winch handle clockwise to extend the jack. See Fig. 3 on the following page. Raise the intake only as much as necessary to attach to the drawbar of the towing vehicle.

NOTE: The support tube and mount tube are shown apart for identification purposes. It is not necessary to take them apart to adjust the rotation.

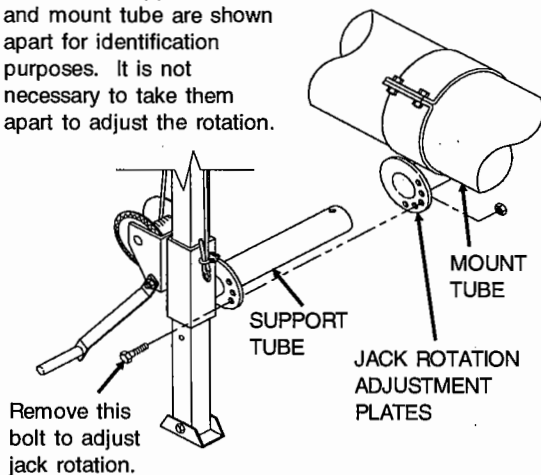

POSITION JACK VERTICAL TO GROUND
FIG. 1



Never raise the intake end higher than necessary. Weight transfers rapidly to the head end when the intake is raised.

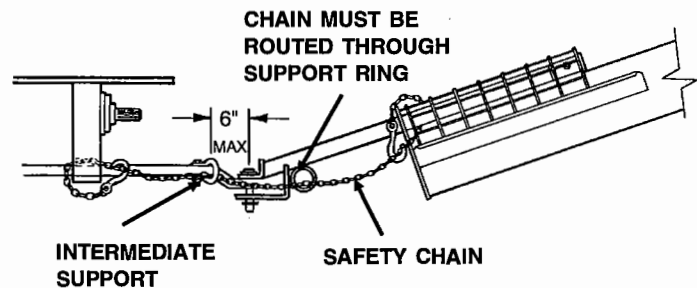

ATTACH SAFETY CHAIN
FIG. 2

2. Pin the auger hitch to the tractor drawbar. Make certain the hitch pin is securely attached.
3. An auxiliary attachment system (safety chain) is required to retain the connection between towing and towed machines in the event of separation of the primary attachment system.

The safety chain should be routed through the intake safety screen and around the hitch pipe. Route the chain through the support ring on the hitch pipe and anchor it to the tractor. A clevis or intermediate chain support should be fastened to the tractor drawbar no farther than 6" from the hitch pin. See Fig. 2. NOTE: The safety chain is not furnished with the auger.

HITCHING TO TRACTOR - CONT.

4. After the auger is secured to the towing vehicle, release the winch lock lever (slight pressure on the winch handle will be necessary) so the cable can be let out and the jack tube raised to transport position. Lift the jack tube until the storage pin can be inserted. See Fig. 4. Remove slack from the cable to eliminate jack vibration.

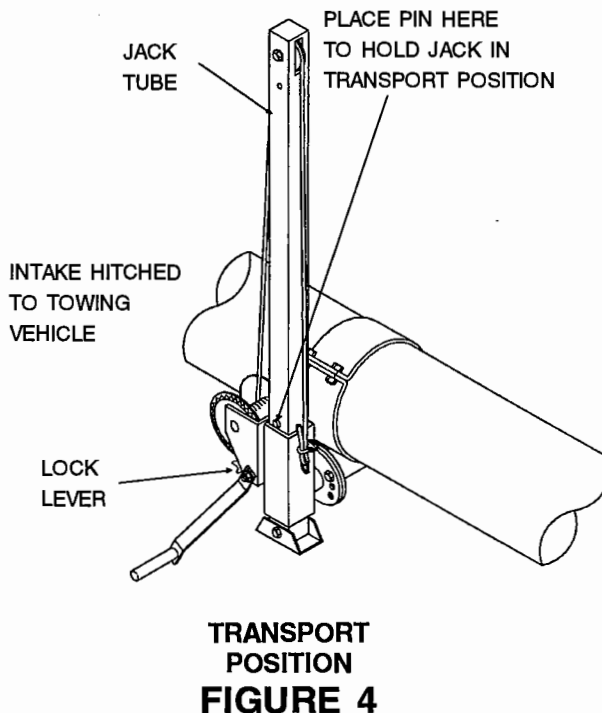
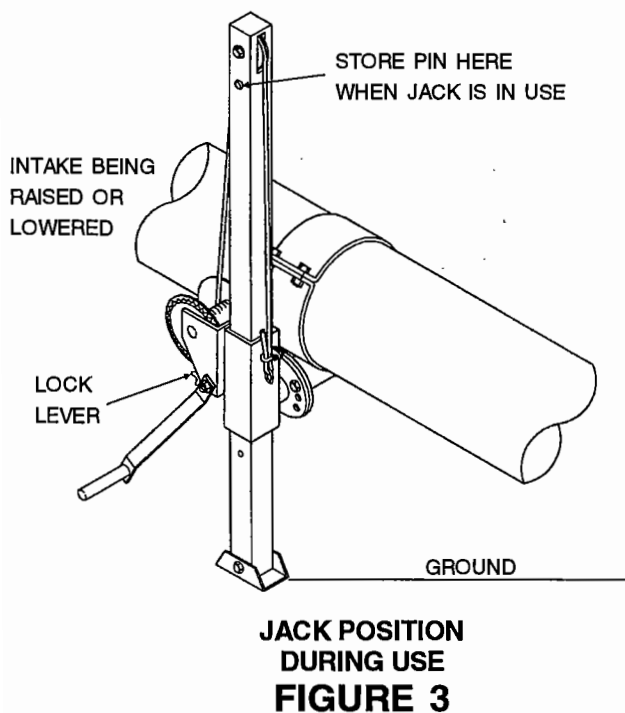

5. On 62', 72' and 82' Models - connect the hydraulic hose to the tractor.



WARNING: Keep all hydraulic lines away from moving parts.



CAUTION: Do not connect or disconnect hydraulic components when there is pressure within the system. Hydraulic systems are highly pressurized. Escaping hydraulic oil, even an invisible pinhole leak, can penetrate body tissues and cause serious injury. Use a piece of wood or cardboard when looking for leaks. Never use the hands or other parts of the body. When reassembling, make absolutely certain that all connections are tight. If injured by hydraulic oil escaping under pressure, see a doctor immediately. Serious infection or reaction may occur if medical attention is not received at once.



TRANSPORTING THE AUGER

Move the auger with a tractor to or from the work area. A pick-up truck or other suitable vehicle may be used for transporting the auger over greater distances. Comply with your state and local regulations governing marking, towing and maximum width. Observe safe driving and operation practices.

Follow these steps when transporting the auger:

1. Always transport your auger in the full-down position.
2. 32' & 42' Models - There should be slight tension on the undercarriage winch cable.
62', 72' & 82' Models - The hydraulic shut-off valve (located at the end of the hose that connects to the tractor) must be closed.
3. Hitch should be secured to tractor and jack stored in transport position. Hitch safety chain must be fastened in place.

Moving your portable auger requires careful planning. Know the transport height of the auger before moving it. Plan your route to avoid overhead obstructions and power lines.

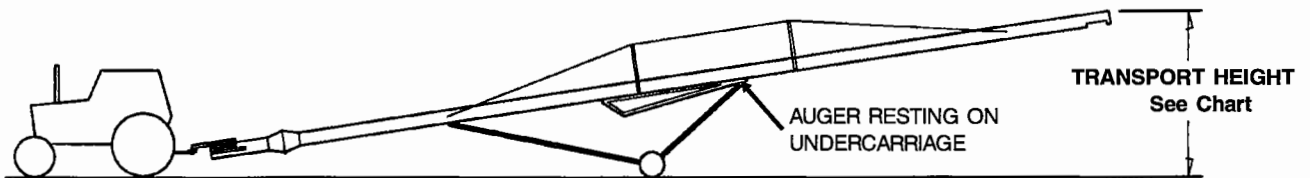

IMPORTANT: Overall transport height is with the auger fully lowered and the intake on the ground. When the auger is attached to a towing vehicle, these heights will be approximately 12" less.

SIZE	12" x 32'	12" x 42'	12" x 62'	12" x 72'	12" x 82'
TRANSPORT HEIGHT	10'-6"	11'-6"	12'-7"	14'-6"	15'-4"



DANGER: Be alert to overhead obstructions and electrical wires. Failure to do so may result in electrocution. Lower auger well below level of power lines before moving. Maintain at least ten (10) feet of clearance. See above chart showing the height of each portable auger in the transport position to determine the height of your auger.

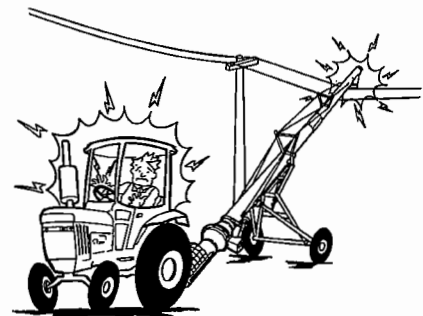

Before moving the auger, the operator should make sure all personnel are clear of the **Moving Auger Hazard Area** as shown in the following diagram. Never allow persons to stand underneath or ride on the auger when it is being transported.

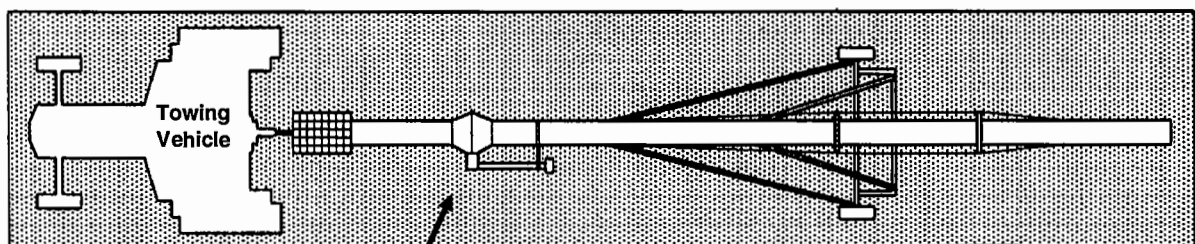

HAZARD AREA - KEEP OUT

PLACEMENT OF AUGER

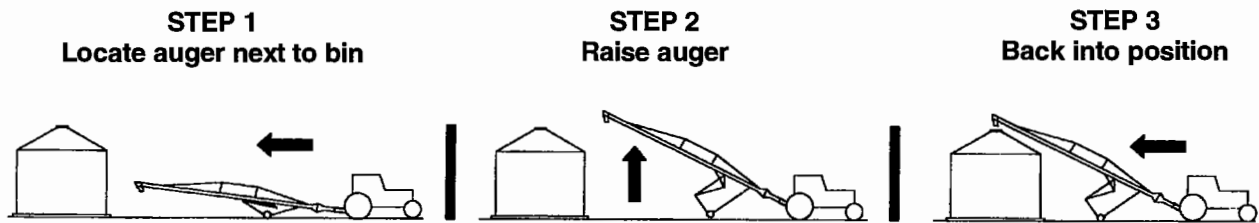

Step 1

Move auger slowly toward working position with a tractor. Locate the auger on level ground as close as possible to the bin or other structure. Leave adequate room for loaded vehicles to reach the auger intake area conveniently. The wheels must be allowed to roll freely when raising. Be sure the area is clear of any obstructions. On 62', 72' & 82' Models - Open the hydraulic shut-off valve.

Make certain everyone is clear of the work area when moving the auger. To prevent tip-over when backing, avoid rolling over any obstructions. Also avoid moving the auger at right angles to a slope. If the auger must set on a slope, approach the bin uphill.



Make sure entire area above auger and in line of travel is clear of overhead obstructions and electrical wires. Failure to do so may result in electrocution. Maintain at least ten (10) feet of clearance. Electrocution can occur without direct contact.

Step 2

Raise the auger only high enough to allow minimum clearance above the bin.

On 62', 72' & 82' Models - Raise or lower the auger by using the hydraulic circuit control lever on the tractor.

On 32' & 42' Models - To raise the auger, turn the winch handle clockwise (pulling cable onto winch drum). There should be a clicking sound. Observe the cable as it is winding onto the winch drum. The cable should roll up on the drum evenly; avoid cable build-up on one side of the drum.

NOTE: The winch is equipped with a brake that is actuated by turning the handle. The brake is designed to hold the load whenever the handle is released.

NOTE: For additional winch instructions, see page 18.



Keep hands away from winch drum during operation.

Don't allow auger to become hung up.

Don't continue to crank the winch after the undercarriage slide reaches the stop.

PLACEMENT OF AUGER

STEP 3

Back auger slowly into working position with a tractor. **NEVER ATTEMPT TO MOVE AUGER BY HAND. USE A VEHICLE. DO NOT ATTEMPT TO INCREASE AUGER HEIGHT BY POSITIONING WHEELS ON LUMBER, BLOCKS OR BY OTHER MEANS.**

1. Lower the auger until the auger discharge is directly over the bin opening. Consider that the discharge end will lower a few inches as the auger fills with grain.

NOTE: When discharging into a grain spreader, maintain at least 12" of space between the auger discharge and the spreader.

On 32' & 42' Models - lower the auger, turn the winch handle counter-clockwise; there will be no clicking sound. To stop while lowering the auger, turn the handle clockwise until you hear two clicks to lock brake. (About a 6" movement of the handle.) NOTE: For additional winch instructions, see page 18.
On 62', 72' & 82' Models - lower the auger by using the hydraulic circuit control lever on the tractor.

2. Once the auger is in place, put the tractor in park.
3. Follow unhitching instructions below.
4. Remove bolt from hitch pipe and remove hitch from auger intake.
5. If a hopper attachment is to be used, install it at this time.
6. Anchor the auger at the intake end and/or support it at the discharge end to prevent tipping from occurring when weight transfers to the top end as the auger empties. It is a good practice to tie the discharge end of the auger to the bin or storage structure to prevent possible wind damage. Remember to untie the auger before attempting to move it.

UN-HITCHING

Follow these steps to unhitch the auger:

NOTE: When the tractor is to be disconnected from an auger in the raised position, anchor the discharge end of the auger to the bin or structure to prevent possible wind damage.

- A. The hydraulic shut-off valve must be closed to prevent possible leakdown.*
- B. Relieve tractor internal hydraulic pressure. Then disconnect the hydraulic hose from the tractor.*
- C. The auger wheels should be chocked to prevent the auger from rolling.
- D. Place jack into the lifting position and remove hitch weight from tractor drawbar. Be sure bolt in adjusting plate is secure to prevent jack from rotating on mount. (See jack operating instructions on pages 4 & 5.
- E. Remove safety chain and hitch pin. Disconnect the tractor from the auger.
- F. Use the jack to lower the intake to the ground.



Never raise the intake end higher than necessary for hitching/unhitching. Weight transfers rapidly to the head end when the intake is lifted, especially when the auger is in a raised position. Never stand between tractor and auger when unhitching unless all controls are in neutral and the brakes locked.

* Does not apply to 32' & 42' models.

DESIGNATED WORK AREA

See page 10 for SAFE WORK AREA rules.

PTO DRIVE UNITS



Overhead
Wires
KEEP AWAY

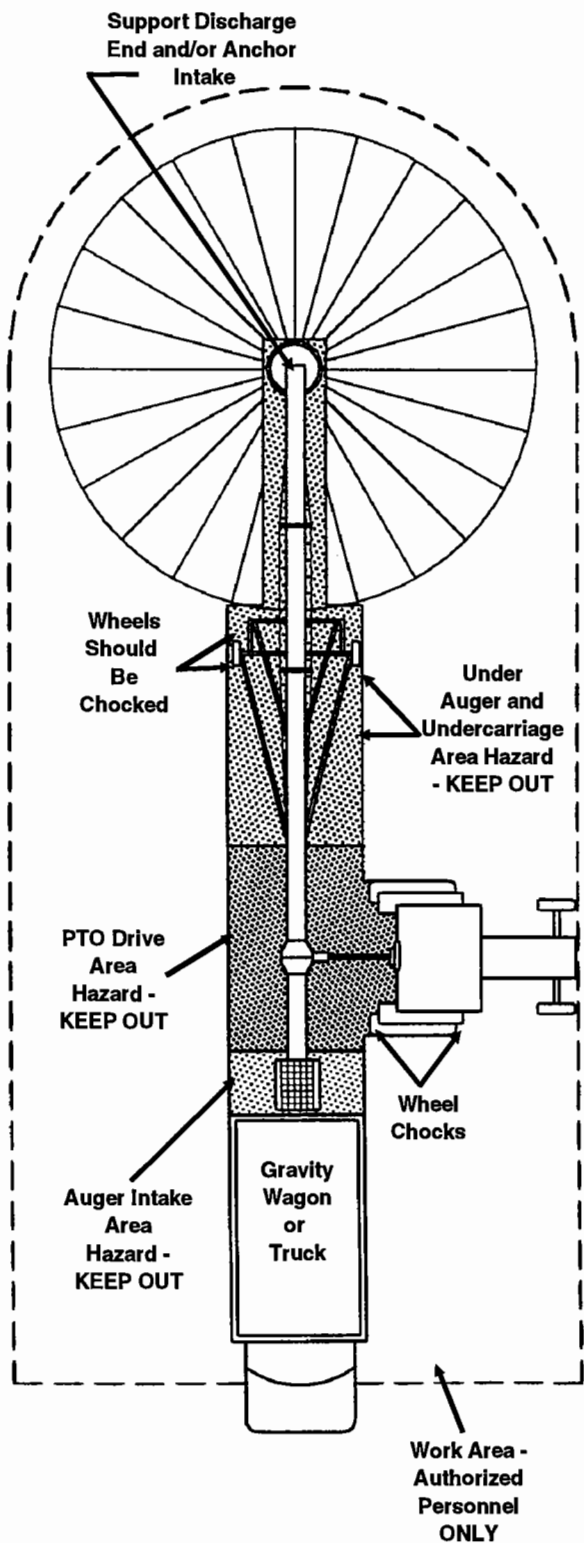

ELECTRIC DRIVE UNITS

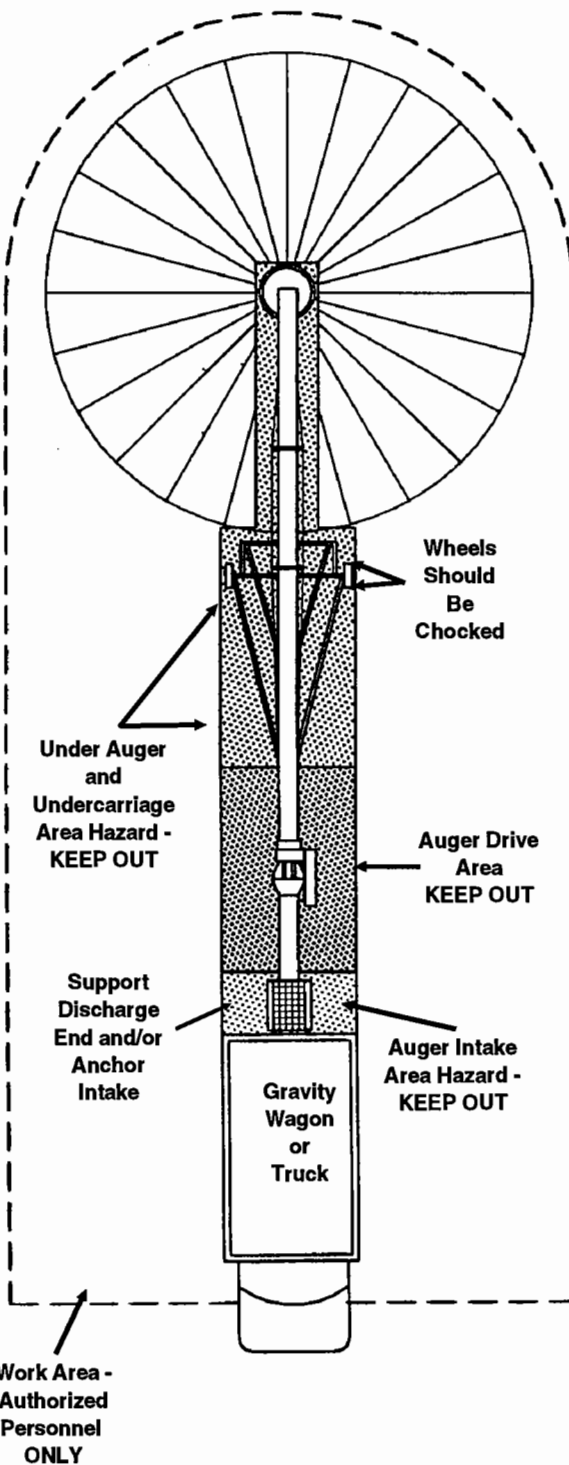

Walking Surface - Is it slippery?
Are there things to trip you?

DESIGNATED WORK AREA

Before starting the auger, a designated work area should be established and properly marked. The diagrams on the previous page show the manufacturer's designated work areas. These areas shall be marked off with colored nylon or plastic rope hung as portable barriers to define the designated work areas.

RULES FOR SAFE WORK AREA

Under no circumstances should persons not involved in the operation be allowed to trespass into the work area.



It shall be the duty of all operators to see that children and/or other persons stay out of the work areas! Trespass into the work area by anyone not involved in the actual operation, or trespass into a hazard area by anyone, shall result in an immediate shut down by the operator.

It shall be the responsibility of all operators to see that the work area has secure footing, is clean and free of all debris, and tools which might cause accidental tripping and/or falling.

OPERATING PROCEDURES

Our augers are well made and we are proud of our line of equipment. We would like you, as our customer, to do your part in using caution and good judgement in using our equipment, as well as any other machinery.

It is important to be familiar with the following routine operation procedures before attempting start-up.

During the operation of your auger, one person shall be in a position to monitor the operation. Inspect the drive before adding power and know how to shut down in an emergency. (See page 14.) Visually inspect the auger periodically during operation. For efficient and safe operation, be aware of all the adjustments and checks which should be performed.

The operator shall have a full view of the auger work area and check that all personnel are clear of hazard areas before adding power.

Keep all safety shields and devices in place.



Keep hands, feet and clothing away from moving parts.

The operator shall be aware of any unusual vibrations, noises and the loosening of any fasteners.

Only use an agricultural tractor which meets the requirements listed on page 4.

This 12" auger may be operated at speeds from 300 to 540 RPM. Auger flight speed in excess of recommended speed causes excessive wear. Do not attempt full load operation at speeds below 300 RPM as high torque requirements may damage the auger.

Close clean-out door on underside of drive housing before operation. Close the drain hole cover on the intake guard.

Never operate the auger empty for any length of time as excessive wear will result. If at all possible, do not stop or start the auger under load, especially before the flight and tube become well polished, as this may cause the auger to "freeze-up". (See BREAK-IN INFORMATION.)

OPERATING PROCEDURES

BREAK-IN INFORMATION

Any screw conveyor when it is new or after it sets idle for a season should go through a "break-in" period. DO NOT operate the auger empty. The auger should be run at partial capacity until several hundred bushels of grain have been augered to polish the flighting assembly and tube. Once this is accomplished, the auger can be run full.

PTO DRIVE INFORMATION

The PTO driveline furnished with the auger is equipped with a "spring-lock" coupler at the tractor end and will fit the standard 1 3/8" x 6 spline PTO output shaft from a tractor.

To attach the driveline to the tractor, compress the spring keeper on the driveline, slide end onto the tractor PTO until the keeper seats in the groove on the shaft. This will lock the PTO driveline onto the tractor PTO.

The PTO driveline is a pin stop type--that is the two telescoping sections will not separate. It is a good practice to operate the PTO driveline in as short a configuration as possible. Keep the PTO driveline in as straight a line as possible during operation. Align PTO driveline with tractor. When connecting tractor and auger, always make sure the tractor axle and side of auger are parallel. See Fig. 5. If the tractor and auger are on unlevel ground or at different levels, place them so the center line of the tractor and the gearbox shaft are parallel. See Fig. 6.

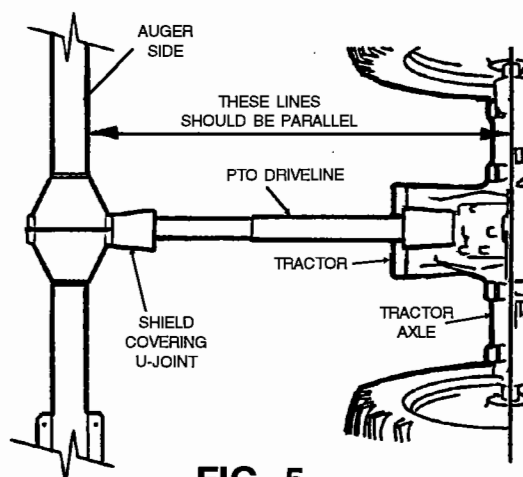

FIG. 5

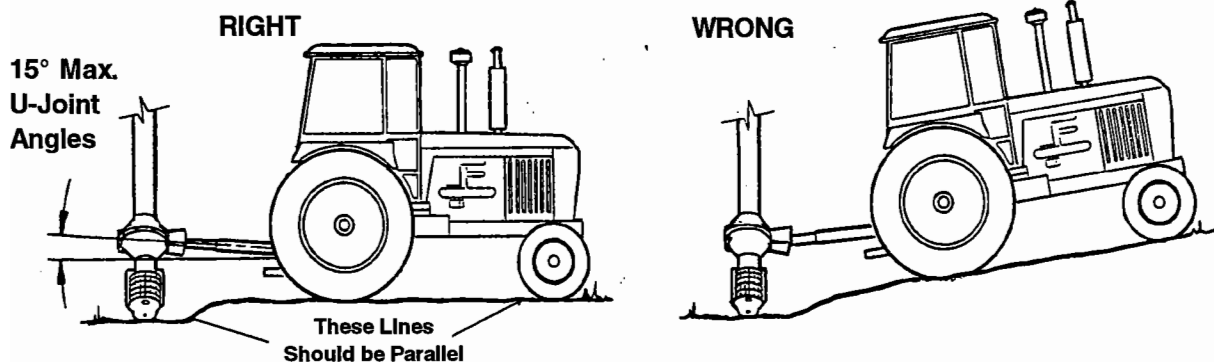

FIG. 6

The PTO driveline is equipped with a shear bolt at the tractor connection. The shear bolt protects the auger from damage if the auger becomes plugged or subjected to high loads. Extra shear bolts are shipped with the auger in the instruction manual container. See page P-13 for replacement shear bolt information.

OPERATING PROCEDURES

PTO DRIVE START-UP

CHECK THE FOLLOWING BEFORE ADDING POWER:

Before starting the tractor, be certain power to PTO is off.

Be certain the PTO driveline is securely attached to the auger and the tractor.



Use a PTO driveline with a rotating shield in good working order that can be turned freely on the shaft.

Stay out of designated hazard area of an operating PTO. Observe work area restriction. (See work area diagram on page 9.)

TO START AUGER:

Engage PTO at a slow RPM to minimize shock loads. Then work up RPM to recommended speed as listed on page 10. The gearbox input to output drive ratio is 1 to 1.

TO STOP AUGER:

1. Let auger empty of grain before stopping.
2. Disengage PTO and lockout.

NOTE: The standard direct PTO may be driven from either side (as explained in the PTO Drive Assembly Section).



Care should be taken when changing the drive from one side of the auger to the other side. To avoid dangerous situations, follow change over instructions on page 42.

OPERATING PROCEDURES

TOP MOUNTED ELECTRIC MOTOR DRIVE INFORMATION

Always use a motor with required H.P. suggested in the chart below. Use a motor that operates at 1750 RPM. Electric motors and controls shall be installed by a qualified electrician and must meet the standards set by the National Electrical Code and all local and state codes. Reset and Motor Starting Controls may be mounted directly to the auger or in a nearby area, but they must be located so that the operator has full view of the entire operation from the control location.

A magnetic starter should be used to protect the motor when starting and stopping. It should stop the motor in case of power interruption, conductor fault, low voltage, circuit interruption, or motor overload. Then the motor must be restarted manually. Some motors have built-in thermal overload protection. If this type motor is used, use only one with a manual reset.



Disconnect power before resetting motor overloads.

Make certain electric motors are grounded.

A 5" motor pulley is recommended. It will produce a flight speed of 475 RPM.

NOTE: Motor pulley is not furnished with the auger.

Model	32'	42'	62'	72'	82'
HP Requirement	15	20	30	30	40

For high moisture grain or other hard to move material, the next larger size motor may be used as a maximum.

ELECTRIC MOTOR DRIVE START UP

BEFORE ADDING POWER:

Check that belt guard is in place, secured and functional.

TO START AUGER

Start electric motor before conveying grain.

TO STOP AUGER

Let auger empty of grain before stopping.

Shut off electric motor and lockout.

OPERATING PROCEDURES

SHUTDOWN

A. NORMAL SHUTDOWN

Make certain that the auger is empty before stopping the unit. Before the operator leaves the work area, the power source shall be locked out. (See LOCKOUT).

B. INTERMITTENT OPERATION SHUTDOWN

When an auger is stopped and restarted under full load, it may result in damage to the auger. Therefore, if intermittent operation is to be carried out, it is advisable to reduce the load level. When kept from absolute filling, auger start-up is easier and operation is more efficient.

C. EMERGENCY SHUTDOWN

Should the auger be immediately shut down under load, disconnect and lockout the power source. Clear as much grain from hopper and auger as you can. Never attempt to start when full. Use clean-out doors. When as much grain as possible has been cleared, reconnect power source and clear auger gradually.

NOTE: Starting the unit under load may result in damage to the auger. Such damage is considered abuse of the equipment.

LOCKOUT



WARNING: If the operator must leave the work area, or whenever servicing or adjusting, the auger must be stopped and the power source turned off. Precaution should be made to prevent anyone from operating the auger when the operator is absent from the work area.

DIRECT PTO DRIVE: Remove ignition key or coil wire from power source. (If this is impossible, remove the PTO driveline from the work area.)

TOP MOUNTED ELECTRIC DRIVE: A main power disconnect switch capable of being locked only in the OFF position shall be provided.

OPERATING CAPACITIES

Capacities of screw conveyors or augers can vary greatly under diverse conditions. Different materials, moisture content, amounts of foreign matter, angle of operation, methods of feeding and speed all play a role in performance of the auger. Roughly 7000 BPH will be achieved augering reasonably dry grain. Maximum possible capacity will be less with high moisture grain (above 15%) than with dry grain.

OPERATING PROCEDURES

RELOCATION OF AUGER

When grain conveying operation is completed, the auger should be moved away from the bin and lowered. The auger can then be moved to a different bin for more conveying operations or cleaned up and stored.

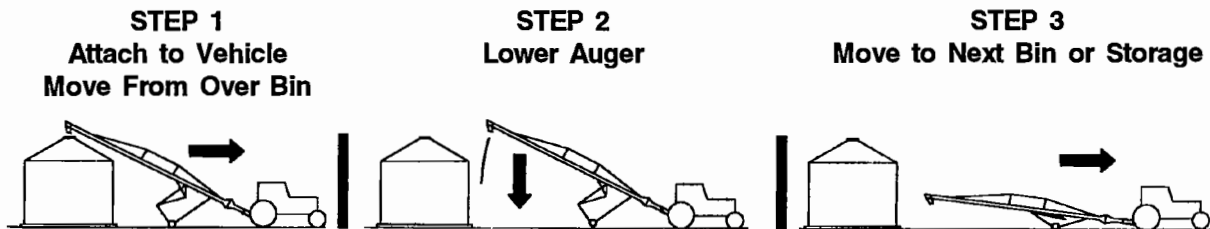

STEP 1

- A. Empty all grain from the auger. Clean up the area.
- B. Untie any anchors and/or remove all supports.
- C. Disconnect the power source.

Top Mounted Electric Drive - Unplug electric motor, wind up electric cables.

Direct PTO Drive - Disconnect PTO driveline from tractor and place in support provided for transporting.

NOTE: The bracket pin must be in place to hold the PTO driveline in the support during transporting.

- D. Install the hitch pipe.
- E. On 62', 72' & 82' Models
Connect the hydraulic hose to the tractor and open hydraulic shut-off valve.
- F. Raise the auger so the discharge spout is clear of bin opening. (See Step 2, Auger Raising Instructions on page 7.)
- G. Hitch the auger intake to the tractor. (See Hitching Instructions on page 4.)
- H. If auger is to be stored or unused for a time, open drain hole cover on intake guard.
- I. Remove wheel chocks.
- J. Move auger slowly away from the bin with the tractor.

STEP 2

- A. Lower auger immediately after clear of bin or storage structure.

IMPORTANT: Lower the auger, even if relocating to a bin in the immediate area.

STEP 3

- A. Move the auger to next bin or the area where the auger is to be stored after use. It is recommended that the auger be stored in the full down position with intake end anchored.
- B. Follow unhitching instructions listed on page 8.
- C. Inspect the auger as outlined in "Machine Inspection" on page 3.

LUBRICATION & MAINTENANCE

For economical and efficient operation of your auger maintain regular and correct lubrication. Neglect leads to reduced efficiency, excessive wear and needless down time. Use the following schedule for best results.



Keep all safety shields and devices in place. Replace any that are damaged or missing. Shut off power and lockout drive to adjust, service or clean.

Any parts needing replacement should be replaced with parts of the same type and size. Do not modify or alter any of the auger components.

PTO DRIVELINE

Augers equipped with PTO driveline, should have the u-joints lubricated at approximately ten (10) hour intervals with SAE multipurpose type grease.



Be sure that PTO driveline shields turn freely on shaft.

The PTO driveline is equipped with a shear bolt at the tractor connection. The shear bolt protects the auger from damage if the auger becomes plugged or subjected to high loads. It is important to use the correct replacement bolt of the proper size and strength to insure that the shear device will protect the auger and operator. Order replacement shear bolt, Part No. 1018892 - 3/8" NC x 1" long grade 8 bolt. Extra shear bolts are provided with auger and are stored in the operator's manual container located under the drive housing.

BEARINGS

Undercarriage Axle Spindle Bearing

Tapered roller type bearings are standard on all 10" augers and should be repacked with grease and adjusted annually or as needed, determined by usage.

Care must be used in dismantling wheel bearing assemblies. See Fig. 7. First remove the dust cap by prying around the edges. Remove the cotter pin, slotted nut and flat washer. Carefully remove the hub and bearings from the spindle. Inspect all parts for wear or damage and replace with new ones, if necessary.

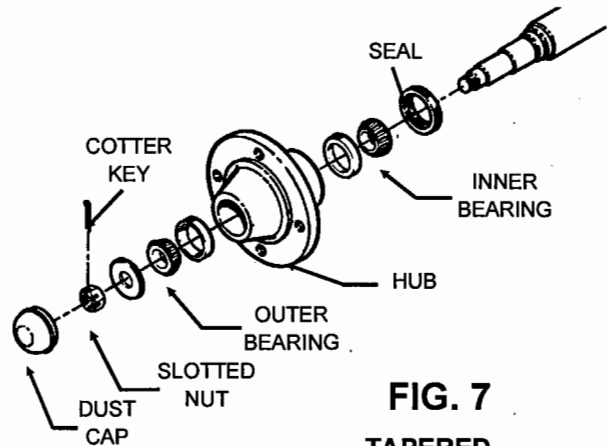

FIG. 7
TAPERED
ROLLER TYPE
BEARING ASSEMBLY

When reassembling the hub, repack both bearing cones with grease and fill the hub cavity 1/3 full. Place inner bearing assemblies into the hub, and then press seal into hub and carefully reinstall the hub on the spindle. When placing hub on spindle be careful not to damage the lip of the grease seal. Install outer bearing assembly into the hub, and replace flat washer and slotted nut. Then tighten the slotted nut to seal the bearings until the hub binds as you rotate hub. Back off the slotted nut to the next slot and install a new 5/32" x 1 1/4" long cotter pin. Replace dust cap.

Intake Guard Bronze Bearing

The auger has a bronze-with-graphite bearing at the intake end. This bearing requires no lubrication. If the bearing spins inside the retainer, the bearing should be replaced.

LUBRICATION AND MAINTENANCE

HYDRAULIC COMPONENTS - For 62', 72' & 82' Models

Standard equipment for your hydraulic auger lift system includes the hydraulic cylinder, shut-off valve, fittings and hydraulic hose from the cylinder to the tractor, with the exception of fittings required to attach hose to tractor. A 1/2" female pipe thread tractor fitting (not furnished) is required to fit the hose leading to the shut-off valve.

The hydraulic shut-off valve, located at the end of the hose that connects to the tractor, must be fully open before raising or lowering the auger. The valve must be closed at all other times to prevent possible leak down or inadvertent hydraulic operation.

The hydraulic cylinder is equipped with a restrictor that limits the speed of operation and a vent plug in the rod end port. Check that the air breather is not plugged. Check the rod seals to see if they are leaking and replace damaged or leaking seals. Check to see if the cylinder is securely fastened to the lifting mounts.

Check the hydraulic hose and all the fittings to see if they are tight and not leaking hydraulic oil. Replace any hose or fittings that develop leaks. Replace the hose if it is cut or damaged. Keep all hydraulic lines away from moving parts.

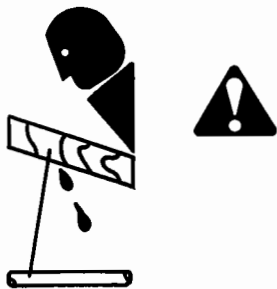

CAUTION: Do not connect or disconnect hydraulic components when there is pressure within the system. Hydraulic systems are highly pressurized. Escaping hydraulic oil, even an invisible pinhole leak, can penetrate body tissues and cause serious injury. Use a piece of wood or cardboard when looking for leaks. Never use the hands or other parts of the body. When reassembling, make absolutely certain that all connections are tight. If injured by hydraulic oil escaping under pressure, see a doctor immediately. Serious infection or reaction may occur if medical attention is not received at once.

The hydraulic components supplied with your auger were selected to deliver the most efficient and economical use. Damaged or worn parts should be replaced with parts of the same type and size.

GEARBOX

Check and maintain oil level regularly. The unit must be level while performing this check. Remove the vented plug from the elbow. Oil is at the proper level when it is visible in the elbow. The use of SAE-80W-90 oil is recommended.

Care should be taken if the drive housing must be disassembled to repair or inspect the gearbox.

NOTE: To avoid dangerous situations, follow disassembly instructions on page 42.

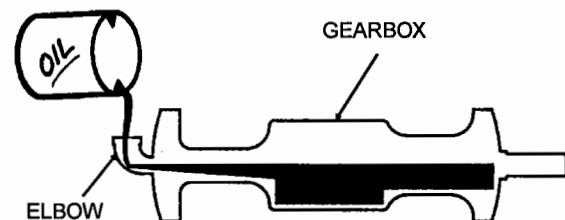

BELT ADJUSTMENT

On drives that are powered by belts, the belt tension will need periodic adjustment. Use the adjustment bolts in the end of the motor mount. Turn equally. DO NOT overtighten.

LUBRICATION & MAINTENANCE

MANUAL (Friction Type) WINCH - For 32' & 42' Model Undercarriage

Check the winch handle assembly on your auger to determine that it has been assembled correctly. (See page 30). There should be a locknut attached to the end of the input shaft to prevent inadvertent removal of the winch handle.

The lubrication checks listed below should be made to the winch periodically.

The auger should be in the lowered position with undercarriage lift arm slide against the upper stop when this inspection is being performed. Refer to operating and maintenance instructions furnished by the winch manufacturer (shipping in the operator's manual container) for proper inspection methods.

1. All gears should have a film of grease on them at all times.
2. Check brake disc. If worn to less than 1/16" thick, cracked or broken, replace both discs.
3. The following parts must be wet with oil at all times:
 - A. Two bushings located at ends of drum shaft.
 - B. The ratchet pawl pivot.

IMPORTANT: Do not get oil or grease on brake disc faces (located between ratchet gear brake hub and pinion shaft.)

See the manufacturer's information sheet that was shipped with this manual for additional instructions.

WINCH FOR JACK

The lubrication checks listed below should be made to the winch periodically. The jack should not be supporting a load when this inspection is being performed. Refer to the operating and maintenance instructions furnished by the winch manufacturer (shipping in the operator's manual container) for proper inspection methods.

1. The spur gears should have a film of grease on them at all times.
2. Maintain a film of grease on outside diameter of drum spacer of drum support bolt.
3. Maintain a few drops of automotive engine oil on ratchet pawl mechanism and bushings.

In addition to the lubrication checks above, the ratchet pawl mechanism must be clean and free of dirt, paint, ice, etc., as these conditions will prevent the ratchet pawl from operating properly.

BLOW-OFF CAP

Before each seasonal use, remove the cap and reinstall. The cap should fit snug, but be able to slide off the end of the tube if the discharge should become plugged. It should be possible to tap the cap off by hand.

FLIGHTING

See "Break-In Information" on page 11. Flighting should be "polished" each season or after an idle period.

TROUBLE SHOOTING

LOW CAPACITY

The auger may not be getting enough grain. Check to see the intake has not "bridged over" restricting the flow.

The exposed flighting at the auger intake should be covered with grain to achieve maximum capacity.

Check auger speed. (Recommended speeds are listed on page 10.) A slow speed (below recommended speed) will result in low capacity. Refer to "Operating Capacities" on page 14.

AUGER PLUGS

The auger may be getting too much grain and be "jamming" inside the housing. Reduce the amount of grain being fed into the auger.

On electric drive augers, the motor may be too small or wired improperly.

If wet grain or other hard to move material is being augered. More horsepower may be required. See page 13.

Is the auger free of any foreign material, such as sacks, tarp corners, etc? A plug of the discharge end will cause an auger plug.

Check to see that all belts are lined up and tensioned properly.

AUGER LOWERING BY ITSELF - On 62', 72' & 82' Models

Check all hydraulic fittings, hose and connections for leaks. Check that the hydraulic shut-off valve is closed.

AUGER WILL NOT RAISE OR LOWER - For 62', 72' & 82' Models

Check if hydraulic shut-off valve is open. See if the hydraulic coupler is properly attached to the tractor and the tractor reservoir is full of oil.

EXCESSIVE AUGER NOISE

Damage may have occurred to the auger flighting, thus causing noise. Damage usually occurs because of foreign material having been run through the auger. It may be necessary to remove the flighting for inspection. If this is to be done, consult Drive Housing Disassembly Instructions on page 42.

ASSEMBLY INSTRUCTIONS

AUGER HOUSING LAYOUT

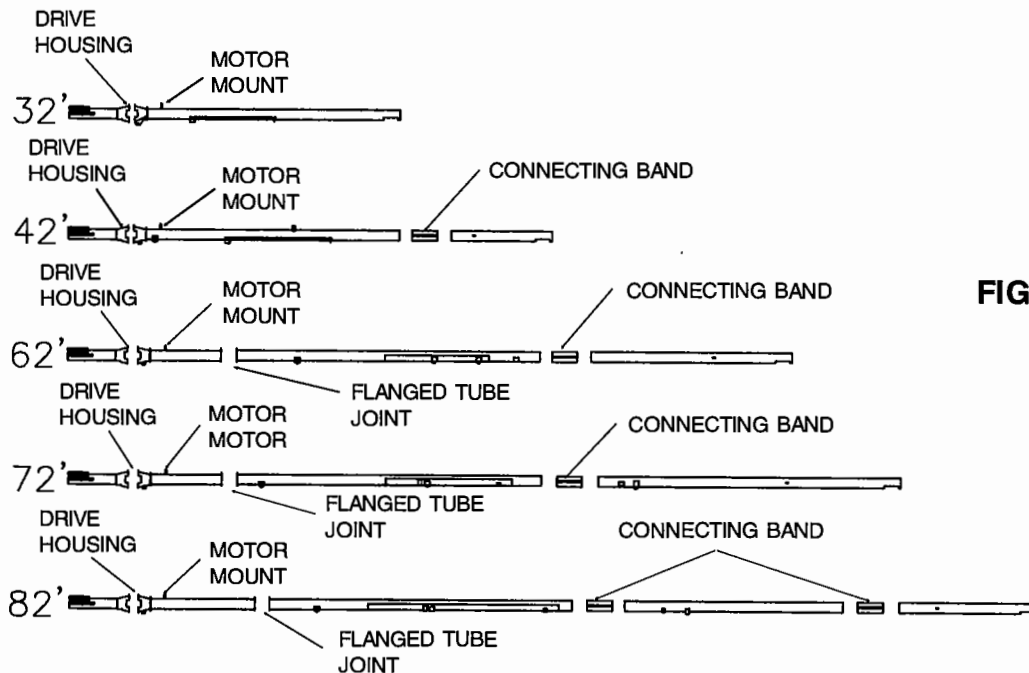

FIG. 8

Choose an area on open level ground accessible to chain hoist or other lifting devices where the auger may be laid out full length. Arrange the tube sections in their relative positions. See Fig. 8. For ease of assembly, place the tubes on stands or blocks so the drive housings are off the ground with the tubes level. Orient electric motor mount brackets in the UP position. Orient undercarriage mounts and channels in the DOWN position.

FLIGHT & GEARBOX ASSEMBLY

1. **Before joining any flights**, slide a connecting band onto the lower tube wherever tubes will be banded. See Fig. 8. Flights located above the gearbox can then be bolted together using 5/8" x 4" long (grade 8) hex head capscrews with side depress locknuts.

IMPORTANT: Flights are indexed to achieve timed connections. (A timed connection is where the flight pitch does not change across the connection.) When bolting timed flight sections together, position the flight ends so that the flighting overlaps and is continuous across the joint. See Fig. 10.

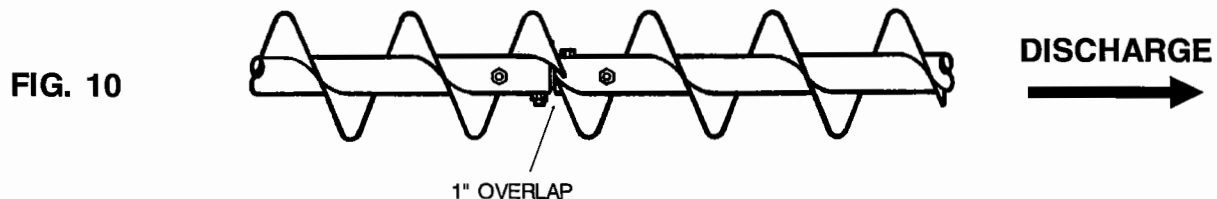

2. Connect the flanged tube joints using twelve 3/8" x 1" long hex head capscrews with two flat washers and a lock nut on each bolt.
3. For banded tube joints, proceed as follows: Push the two tube sections together as tightly as possible. Slide the connecting band over the joint with about half the band on each side. Secure the band with eight 3/8" x 1 1/2" long (grade 5) hex head capscrews with nylon locknuts. See Fig. 11 on the following page.

ASSEMBLY INSTRUCTIONS

FLIGHT, GEARBOX & HOUSING ASSEMBLY - CONT.

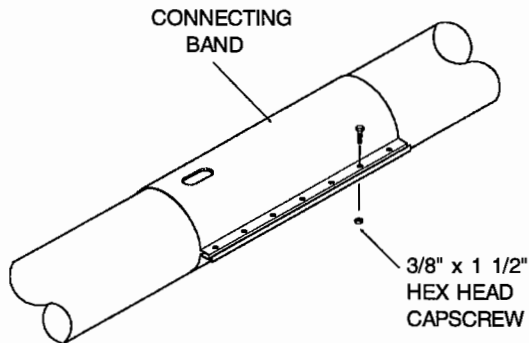
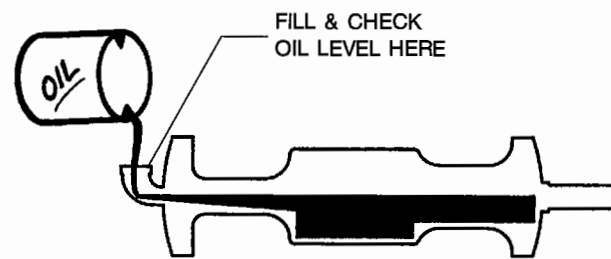

FIG. 11



IMPORTANT: DO NOT operate without oil!

FIG. 12

NOTE: If the unit is to be PTO driven, the drive can be assembled on either the right or left side of the auger. Fig. 6 on page 11 shows a PTO drive installed on the right-hand side. The gearbox is shipped ready for right hand installation. See Fig. 13. To convert it for left-hand installation, rotate the gearbox filler elbow 180° (so it will be pointing up after the gearbox is installed). See inset, Fig. 13.

NOTE: If the unit is to be motor driven, the gearbox is ready to assemble as shown in Fig. 13. and must not be converted.

- The gearbox is shipped without oil. Add 35 oz. of SAE 80W-90 to the gearbox using the vented plug in the elbow. Check oil level with the unit on level ground. Oil must be visible in the elbow. Fig. 12.
- Connect the upper gearbox shaft (beveled) to the upper flight assembly using two 5/8" x 4 1/2" long (gr. 8) hex head cap screws, four 5/8" rubber washers, four 5/8" washers, and nylon locknuts. Tighten the lock nuts only enough to slightly compress the 5/8" x 1/4" thick rubber washers. **DO NOT** compress the washers more than 1/16" Fig. 13.

NOTE: Before the following connections are made, a sealant may be applied to the drive housing flanges. (Sealant not furnished.)

- Assemble the gearbox to the upper drive housing using four 1/2" x 1" long (grade 5) hex head cap screws and lockwashers.

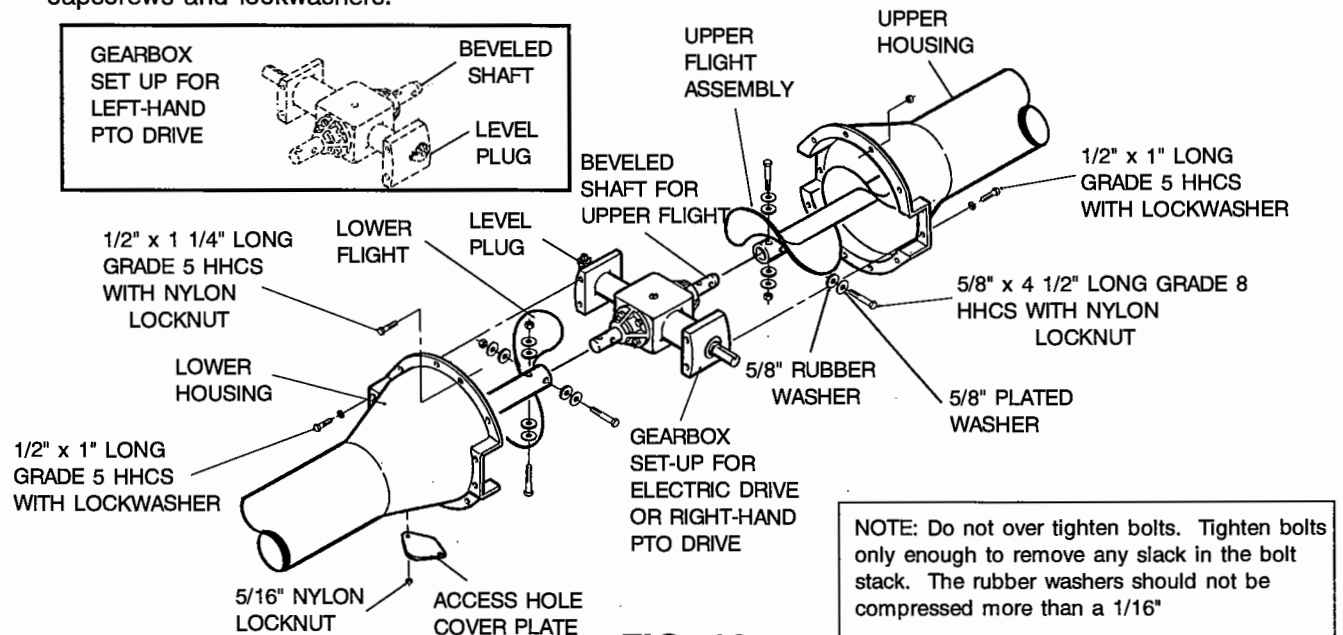

FIG. 13

NOTE: Do not over tighten bolts. Tighten bolts only enough to remove any slack in the bolt stack. The rubber washers should not be compressed more than a 1/16"

ASSEMBLY INSTRUCTIONS

FLIGHT, GEARBOX & HOUSING ASSEMBLY

IMPORTANT:
When bolting the flight sections to the gearbox, the orientation of the flight sections to each other is important for flight balance and smooth operation. The ends of the flight sections should be on the same side of the gearbox.

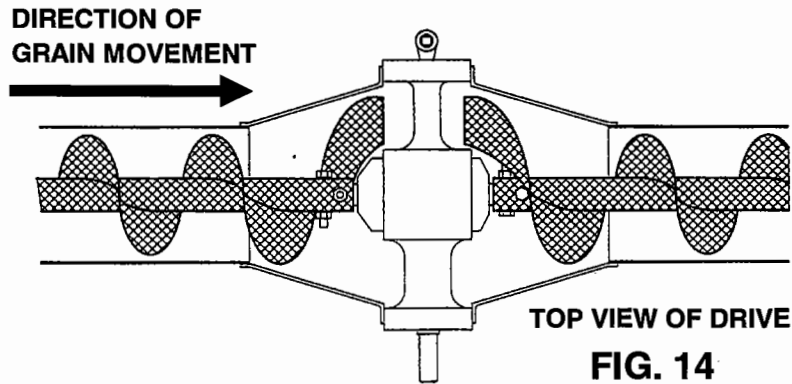

7. Connect the lower flight to the gearbox with two 5/8" x 4 1/2" long (grade 8) hex head capscrews, four 5/8" rubber washers, four 5/8" washers and nylon locknuts. See Fig. 13 and 14.
8. Bolt the lower drive housing to the gearbox with four 1/2" x 1" long (grade 5) hex head capscrews and lockwashers. See Fig. 13 on previous page. When joining the drive housings, be careful to align the flight tail stub with the bronze bearing located on the intake guard.
9. Join the drive housing flanges using 1/2" x 1 1/4" (grade 5) hex head capscrews with nylon locknuts in the remaining holes.
10. Bolt the access hole cover plate to the lower drive housing with 5/16" nylon locknuts.

FLIGHT, GEARBOX AND HOUSING ASSEMBLY FOR UNITS EQUIPPED WITH INTERMEDIATE FLIGHT BEARINGS

1. Before joining any flights, slide a connecting band onto the lower tube wherever tubes will be banded. See Fig. 8 on page 20.
2. For flights located above the gearbox, slide a bearing hanger onto each flight connecting stub, then connect the flight sections together using 5/8" x 4" long (grade 8) hex head capscrews with side depress locknuts. See Fig. 15. The bearing hanger can then be allowed to rotate downward.

IMPORTANT: Flights are indexed to achieve timed connections. (A timed connection is where the flight pitch does not change across the connection.) When bolting timed flight sections together at the intermediate bearings, position the flight ends so they are open 90° to 180° to one another.

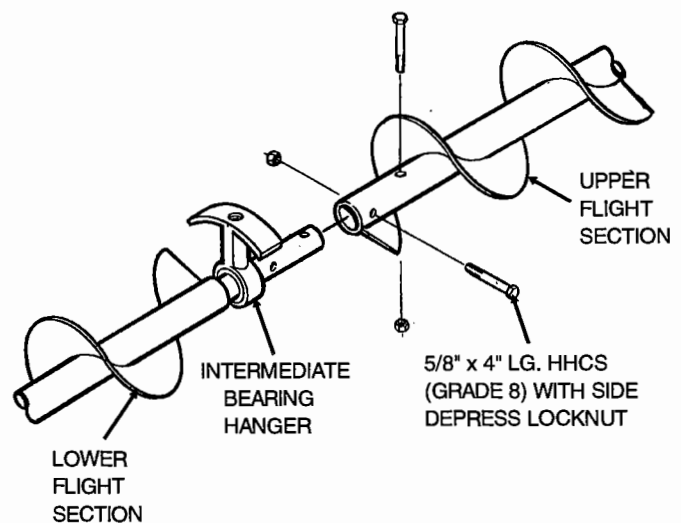

FIG. 15

ASSEMBLY INSTRUCTIONS

FLIGHT, GEARBOX & HOUSING ASSEMBLY - CONT. FOR UNITS WITH OPTIONAL INTERMEDIATE FLIGHT BEARINGS

3. Connect the flanged tube joints using twelve 3/8" x 1" long hex head capscrews with two flat washers and a lock nut on each bolt.
4. For banded tube joints, proceed as follows: Push the two tube sections together as tightly as possible. Slide the connecting band over the joint with about half the band on each side of the joint. Secure the band with eight 3/8" x 1 1/2" long (grade 5) hex head capscrews with nylon locknuts. See Fig. 11 on page 21.
5. Complete Steps 4 thru 10 on page 21 & 22 to assemble gearbox, housing and flight. After all tubes and flights have been connected, the intermediate bearings can be mounted to the tubes. A special tool (called a "bearing positioning bar") has been provided to position the bearing hangers for assembly.
6. Use the bearing positioning bar to grab the bearing hanger stem through the housing slot to rotate the hanger into its upward position as follows:
 - A. Insert the double bended end of bearing positioning bar into slot and hook the bearing hanger stem. Rotate the stem upward as much as possible. See Fig. 16.
 - B. Remove the positioning bar and insert the single bent end into slot. Hook the bearing hanger stem and, by pulling upward, rotate it completely upright. See Fig. 17.

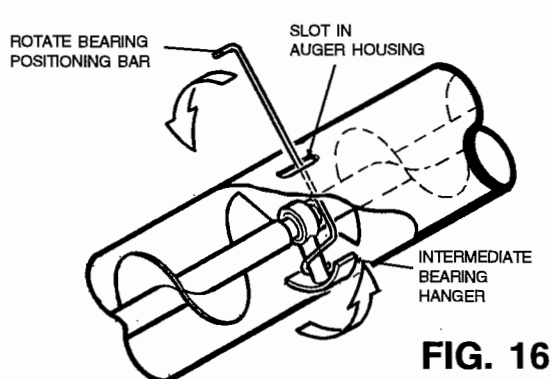

FIG. 16

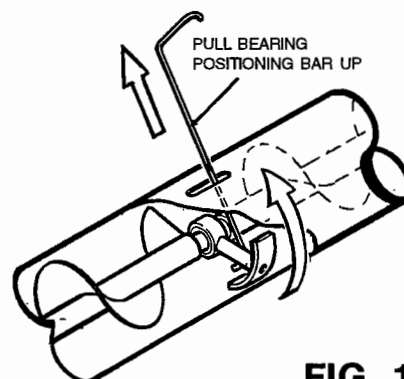

FIG. 17

- C. Attach each bearing hanger to the auger housing using a mounting plate, a 3/4" x 1 1/2" long (grade 5) hex head capscrew and lockwasher as seen in Fig. 18. Before tightening the mounting bolts, adjust the bearing hangers so they are centered between the ends of the auger flights. (See Fig. 19.) This can be done by sliding the hanger back and forth in the slot to determine the approximate center.

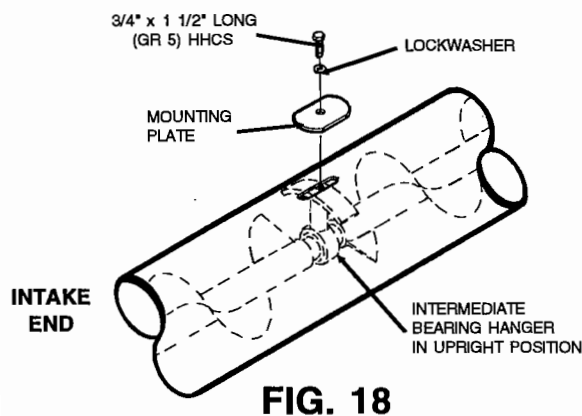

FIG. 18

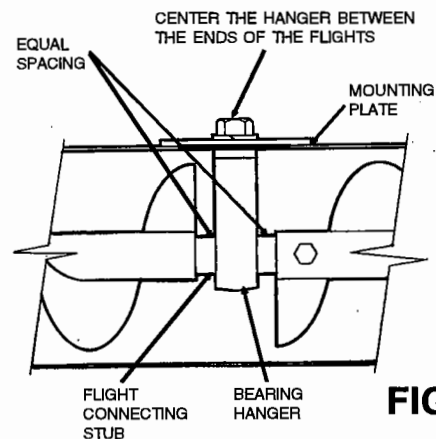

FIG. 19

ASSEMBLY INSTRUCTIONS

TOP TRUSS ASSEMBLY FOR 42' MODEL AUGER

- Step 1. Loosely bolt center truss sides to truss mount. Use two 1/2" x 1 1/2" long hex head capscrews (grade 5) with a Nylock locknut for each side. See Fig. 20.
- Step 2. Bolt the cross brace between the truss sides with two 3/8" x 1 1/4" hex head capscrew (grade 5) with Nylock locknuts.
- Step 3. Attach cables to cable anchors at the discharge end with two 3/8" cable clamps on each cable.
NOTE: Secure the clamp u-bolt against the loose end of the cable.
- Step 4. Run the cable over the truss cross brace, then toward the intake end of auger. Attach cables to the top of the truss using a 3/8" cable clamp. **DO NOT** tighten cable clamps at this time. See Fig. 21.
- Step 5. Install eyebolts through lower cable anchors at intake end, using two nuts. See Fig. 23.
- Step 6. Attach cables to eyebolts using two cable clamps. The clamp u-bolt must be against the loose end of the cable.
- Step 7. Using eyebolts, tighten cables to remove slack until the cables are reasonably snug. Tighten cables equally. **DO NOT** over tighten. Sight down the tube to make sure all sections are straight. Tighten the 3/8" cable clamps assembled in Step 4. Some adjustment can be made after auger is set up on the undercarriage.

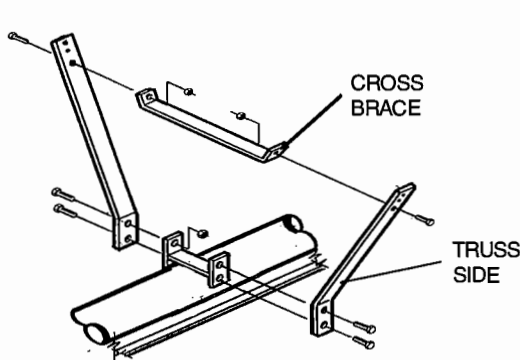

FIG. 20
TRUSS ASSEMBLY

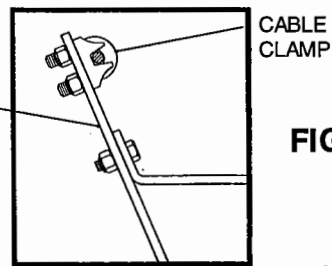

FIG. 21

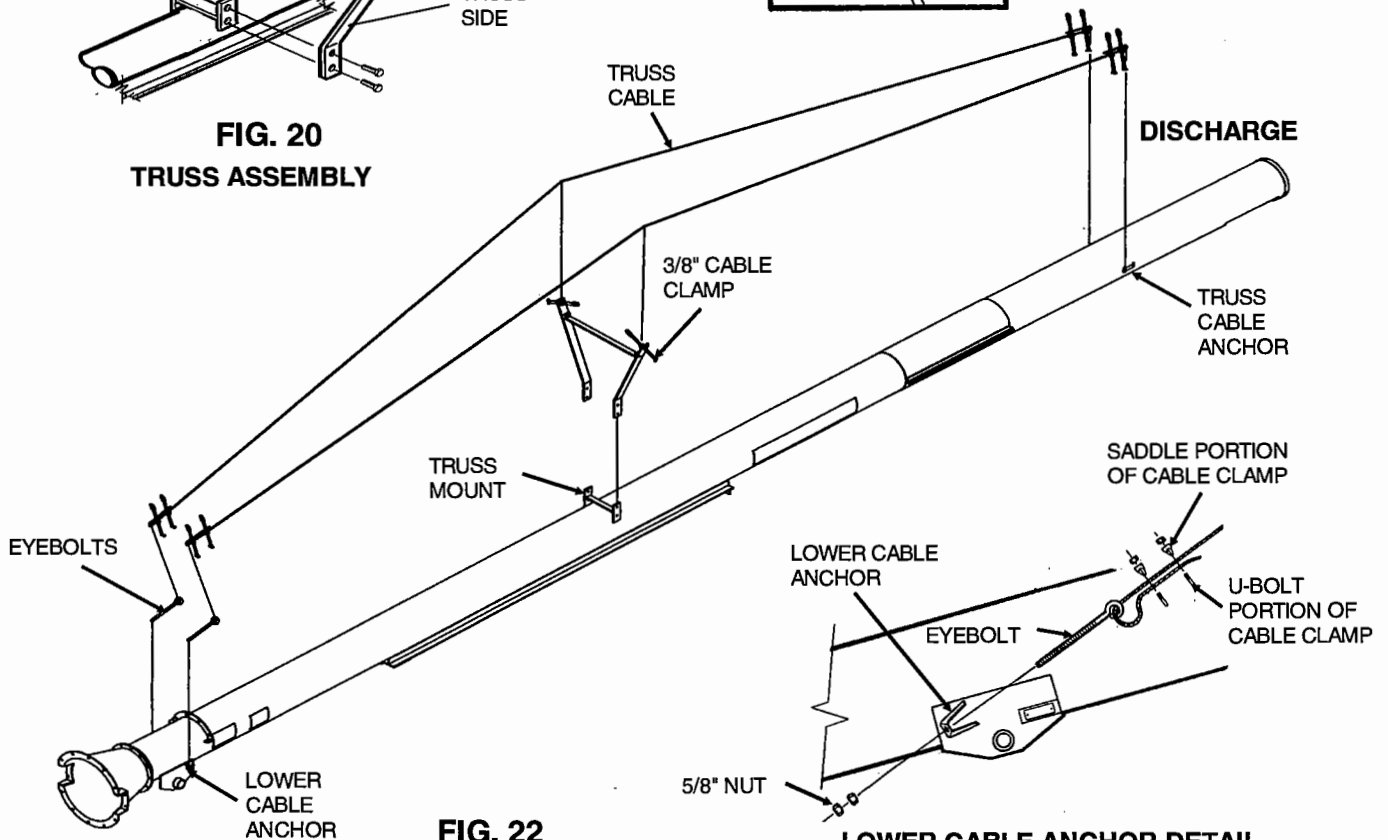

FIG. 22

LOWER CABLE ANCHOR DETAIL

FIG. 23

ASSEMBLY INSTRUCTIONS

TOP TRUSS ASSEMBLY FOR 62' MODEL AUGER

- Step 1. Bolt center truss to mounting ears on auger using two 5/8" x 1 1/2" long (grade 5) hex head capscrews and nylon locknuts. See Fig. 26.
- Step 2. Attach cables to cable anchors at discharge end with two 3/8" cable clamps on each cable.
NOTE: Secure the clamp u-bolt against loose end of cable.
- Step 3. Run the cables over the truss cross brace, then toward the intake end of auger. Attach cables to the top of the truss using a 3/8" cable clamp. **DO NOT** tighten cable clamps at this time. See Fig. 25.
- Step 4. Install eyebolts through lower cable anchors at intake end, using two nuts. See Fig. 23.
- Step 5. Attach cables to eyebolts using two cable clamps. The clamp u-bolt must be against the loose end of the cable.
- Step 6. Using eyebolts, tighten cables to remove slack until the cables are reasonably snug. Tighten cables equally. **DO NOT** over tighten. Sight down the tube to make sure all sections are straight. Tighten the 3/8" cable clamps assembled in Step 3. Some adjustment can be made after auger is set up on the undercarriage.

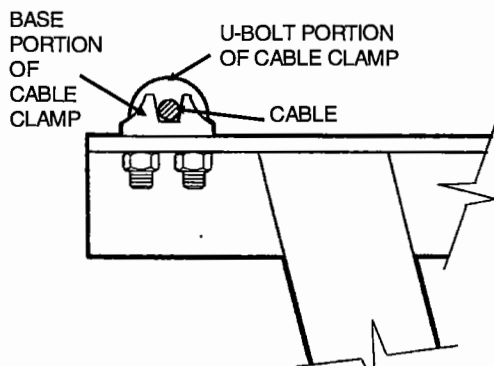

TRUSS CABLE TO TRUSS FRAME

FIG. 25

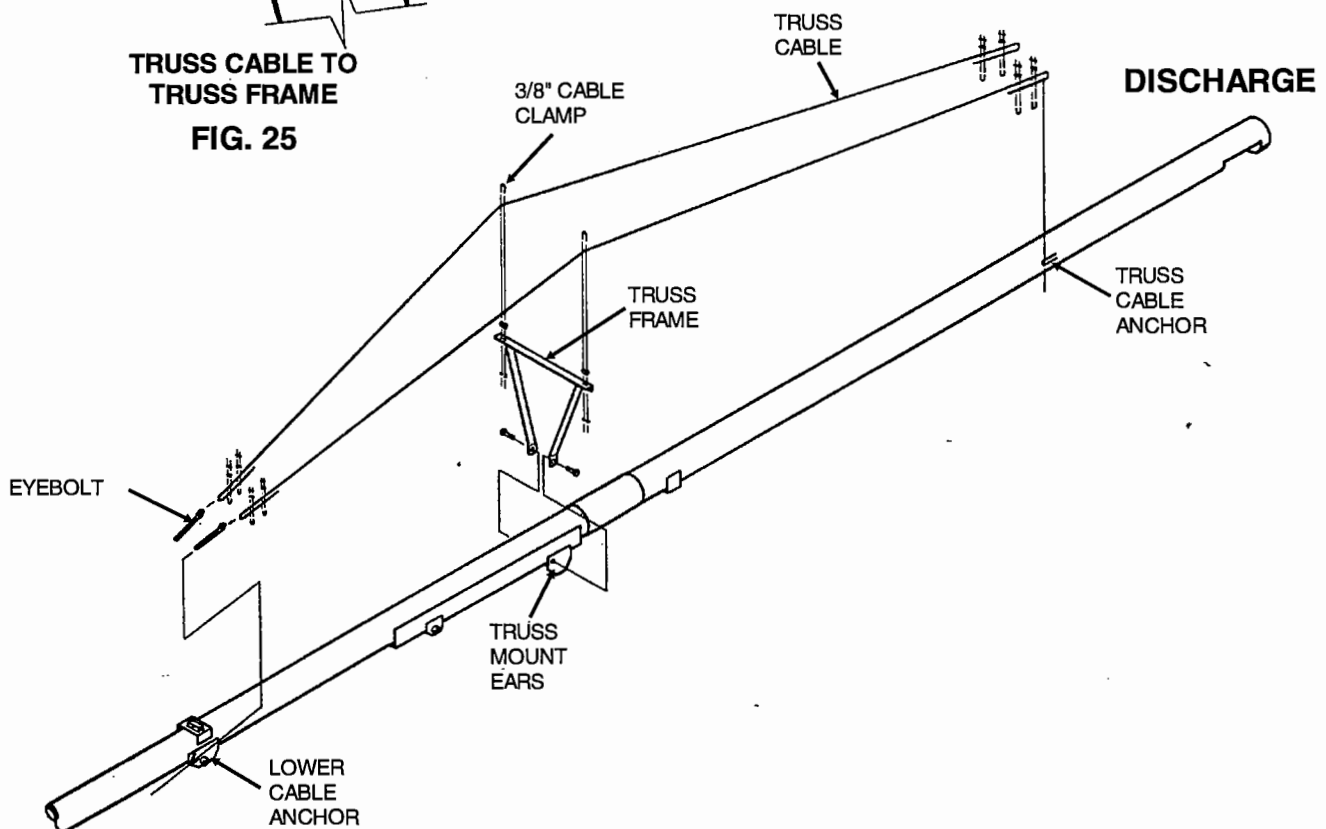
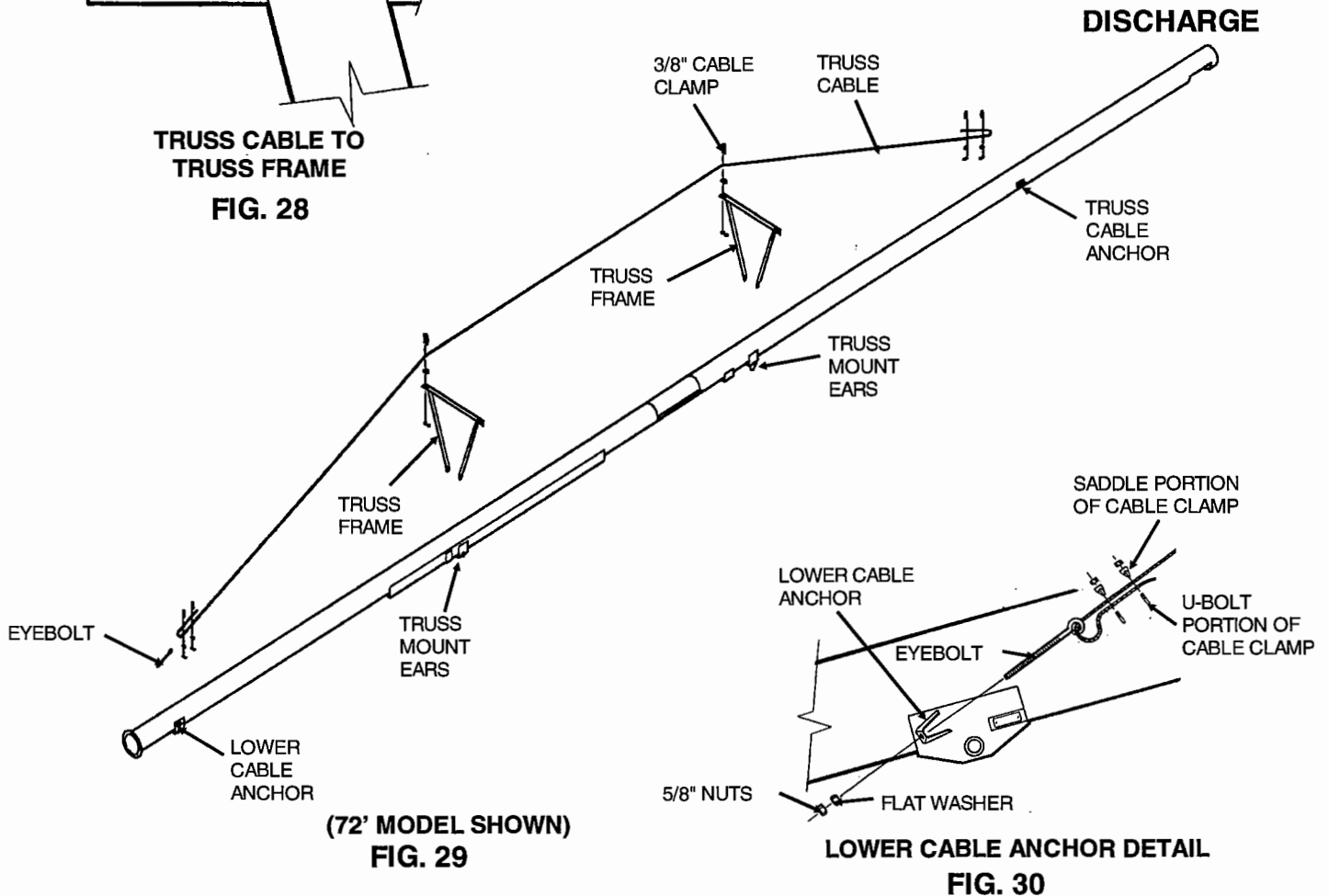
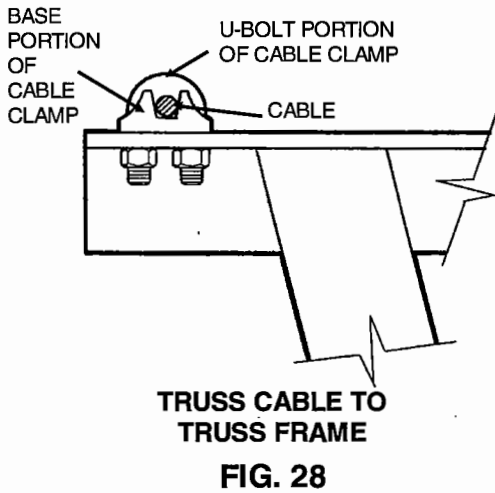

FIG. 26

ASSEMBLY INSTRUCTIONS

TOP TRUSS ASSEMBLY FOR 72' AND 82' MODEL AUGER

- Step 1. Bolt the two truss frames to mounting ears on the auger using two 5/8" x 1 1/2" long (grade 5) hex head capscrews and nylon locknuts each. See Fig. 29.
- Step 2. Attach cables to cable anchors at discharge end with two 3/8" cable clamps on each cable.
NOTE: Secure the clamp u-bolt against loose end of cable.
- Step 3. Run the cables over the truss frames, then toward the intake end of auger. Attach cables to the truss frames using 3/8" cable clamps. **DO NOT** tighten cable clamps at this time. See Fig. 28.
- Step 4. Install eyebolts through lower cable anchors, using two nuts. See Fig. 30.
- Step 5. Attach cables to eyebolts using two 3/8" cable clamps. The clamp u-bolt must be against the loose end of the cable.
- Step 6. Using eyebolts, tighten cables until they are reasonably snug. Tighten cables equally.
DO NOT over tighten. Sight down the tube to make sure all sections are straight. Tighten the cable clamps assembled in Step 3. Some adjustment can be made after auger is set up on the undercarriage.



ASSEMBLY INSTRUCTIONS

TRACK, TRUSS AND UNDERCARRIAGE ASSEMBLY FOR MANUAL LIFT UNDERCARRIAGE MODELS - CONT.

TRACK CABLE PULLEY AND CLEVIS COMPONENTS

Step 1. Assemble the cable pulley(s) to the short clevis. Then fasten clevis to anchor at lower end of track using 5/8" x 4" long (grade 5) hex head capscrew and nylon locknut.

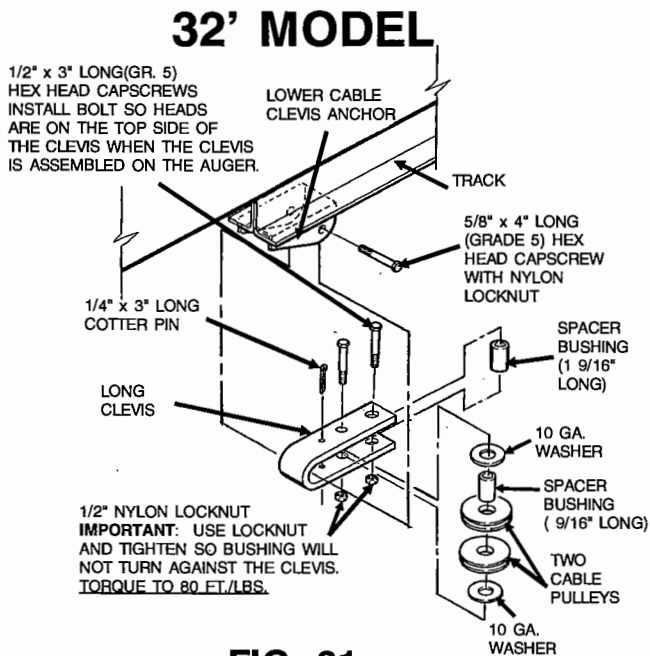

FIG. 31

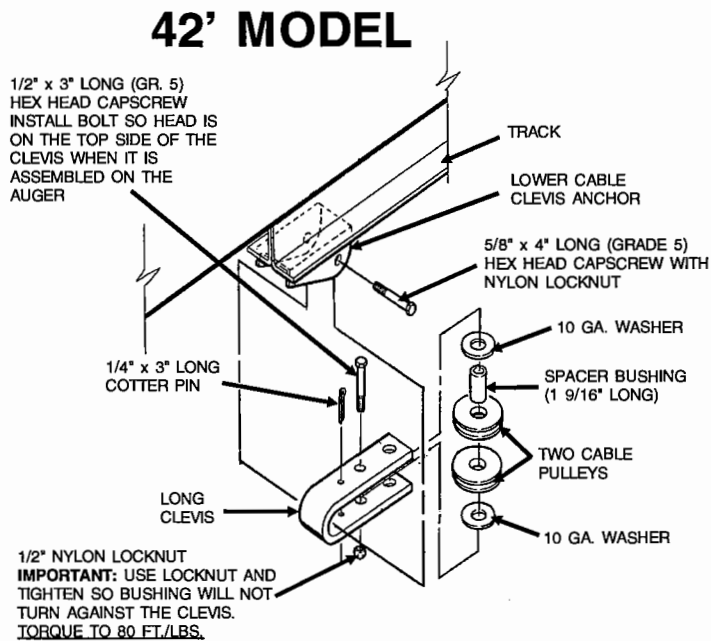

FIG. 32

Step 2. Assemble pulley(s), spacer bushings, washers and cotter pin to long clevis.

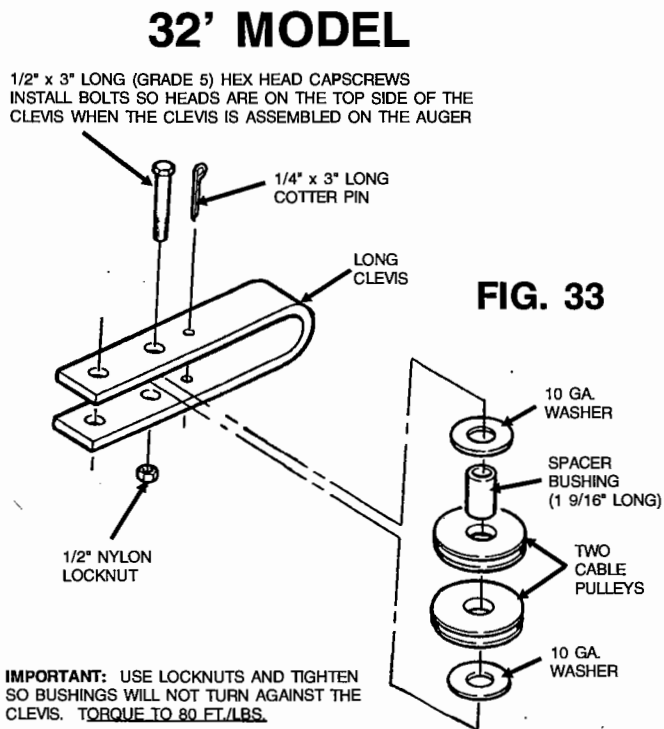

FIG. 33

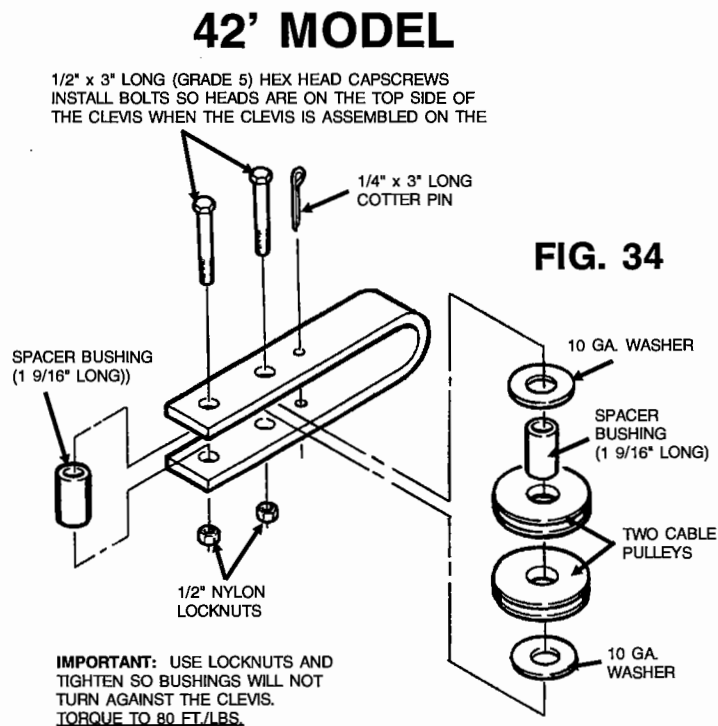

FIG. 34

ASSEMBLY INSTRUCTIONS

TRACK, TRUSS AND UNDERCARRIAGE ASSEMBLY FOR MANUAL LIFT UNDERCARRIAGE - CONT.

RADIUS ROD AND AXLE LEG COMPONENTS

**32' & 42'
MODELS**

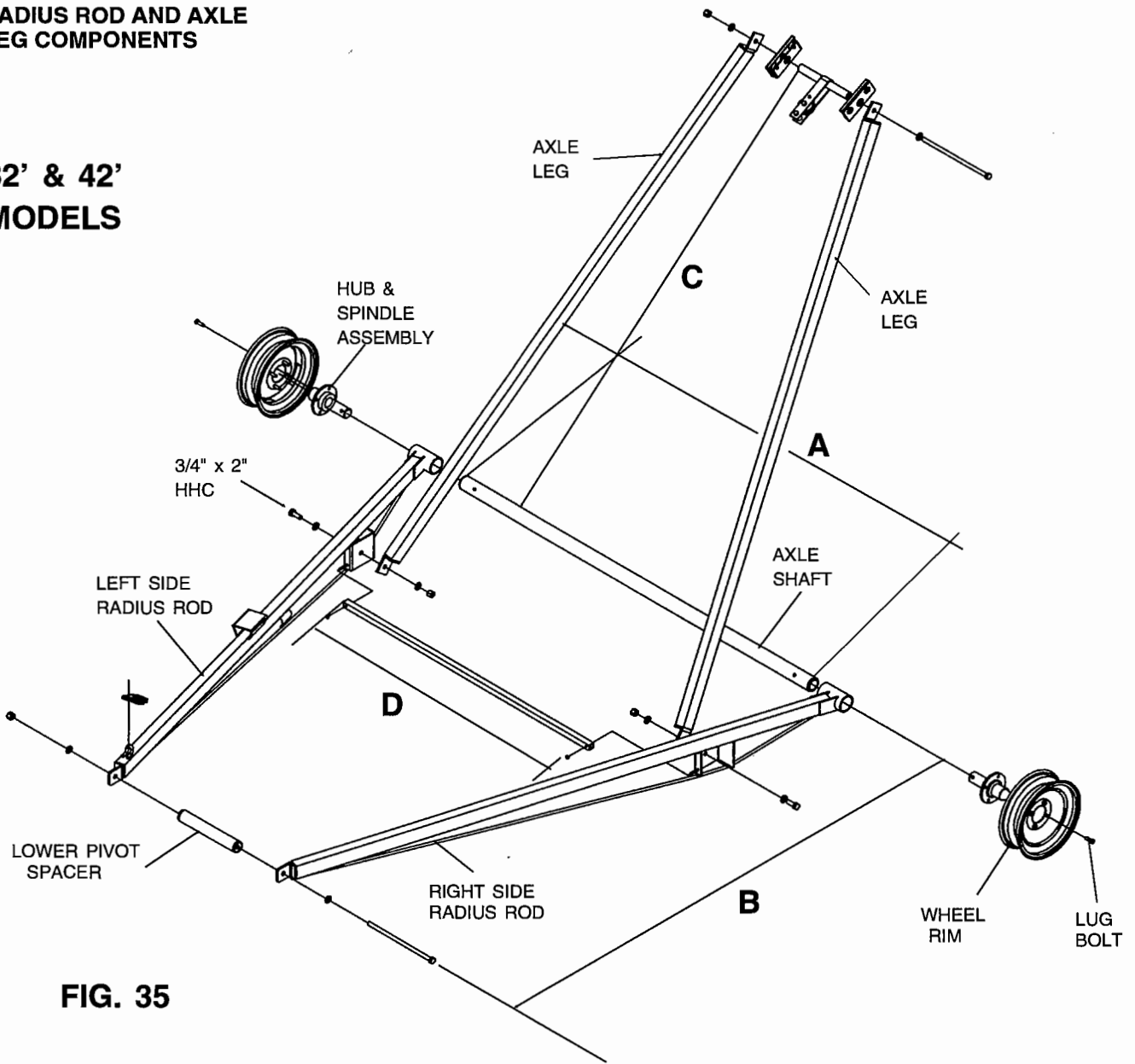

FIG. 35

**UNDERCARRIAGE COMPONENTS
FOR MANUAL LIFT UNDERCARRIAGE**

MODELS	32'	42'
AXLE LENGTH "A"	94 1/2"	94 1/2"
RADIUS ROD LENGTH "B"	94 1/4"	116 3/4"
AXLE LEG LENGTH "C"	97 1/2"	124 1/8"
CROSS TUBE LENGTH "D"	63 1/2"	66 1/2"

ASSEMBLY INSTRUCTIONS

TRACK, TRUSS AND UNDERCARRIAGE ASSEMBLY FOR MANUAL LIFT UNDERCARRIAGE MODELS - (CONT.)

WINCH AND CABLE COMPONENTS

Step 3. Hook clevis plates over anchor rod on left radius rod. Then assemble bushing, flat washers and cable pulley between the clevis plates using 1/2" x 2" long (grade 5) hex head capscrew and nylon locknut. After the locknut is tightened, check to see that the clevis plates are captured on the anchor rod and cannot come off. See Fig. 36.

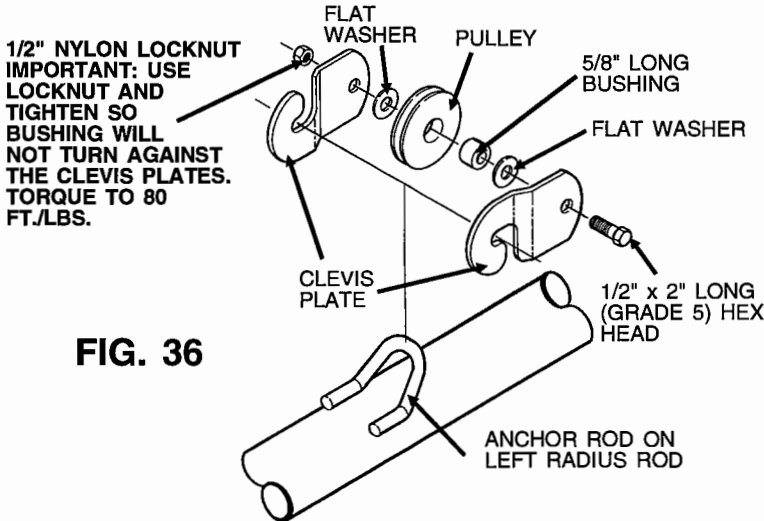

FIG. 36

Step 4. Align slot of handle with flat portion of winch pinion shaft. Use hex nut to hold handle in place and tighten securely. For additional winch information, follow the instructions and precautions listed in the material supplied with the winch from the manufacturer. See Fig. 37.

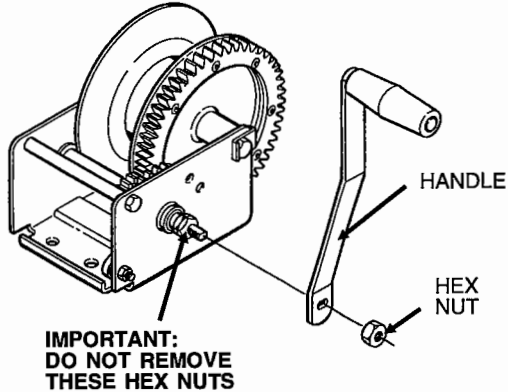

FIG. 37

Step 5. Attach 1/4" lift cable to winch drum so cable will wrap over winch drum on 32' & 42' models when turning handle in a clockwise direction. See Fig. 38. From inside of drum, insert the cable through one round hole in the drum side, until it extends 1" past the two square holes. Next clamp the cable to the outside of the drum with the cable keeper, using two 3/16" x 3/4" carriage bolts, lock washers and nuts. Be sure that the carriage bolt heads are on the inside of the drum.

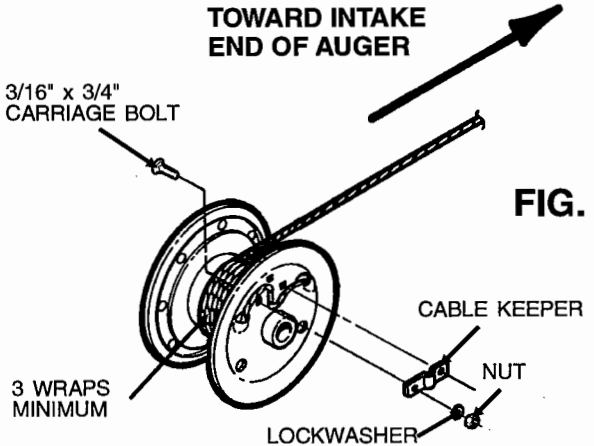

FIG. 38



CAUTION: The rope keeper alone will not hold the weight of the auger. There should be enough cable so that when the auger is all the way down there are at least 3 turns of cable on the winch drum. Never let the cable all the way out. Always keep a minimum of three (3) turns of cable on the winch drum. If there are not (3) turns of cable around the winch drum when the auger is fully lowered, then the cable must be replaced with a longer cable.

ASSEMBLY INSTRUCTIONS

TRACK, TRUSS AND UNDERCARRIAGE ASSEMBLY FOR MANUAL LIFT UNDERCARRIAGE - CONT.

WINCH AND CABLE COMPONENTS

Step 6. Bolt winch assembly to mount left radius rod so the winch drum is towards the intake end of auger. Use three 3/8" x 1" long (grade 5) hex head capscrews, flat washers, and nylon locknuts to attach winch to mount. See Fig. 39.



Never fully extend the cable and always keep three complete turns of cable around winch drum.

Step 7. Rig the lift cable from the winch through the various pulleys and anchor to trolley. Different lengths of augers will require different rigging of the lift cable. See Fig. 40 for 32' models or Fig. 41 for 42' model.

IMPORTANT: Secure lift cable to trolley with two cable clamps, with the clamp u-bolt against the loose end of the cable.

IMPORTANT: Do not disassemble pulley(s) from clevis(s) during rigging.

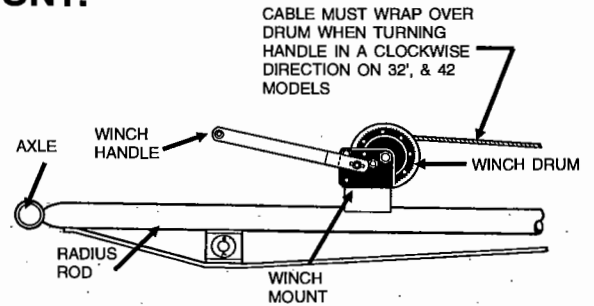
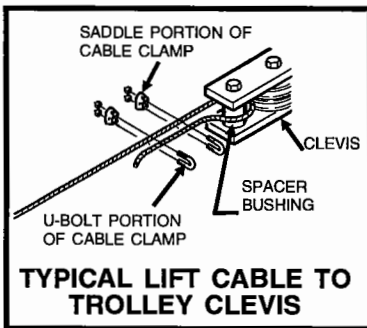
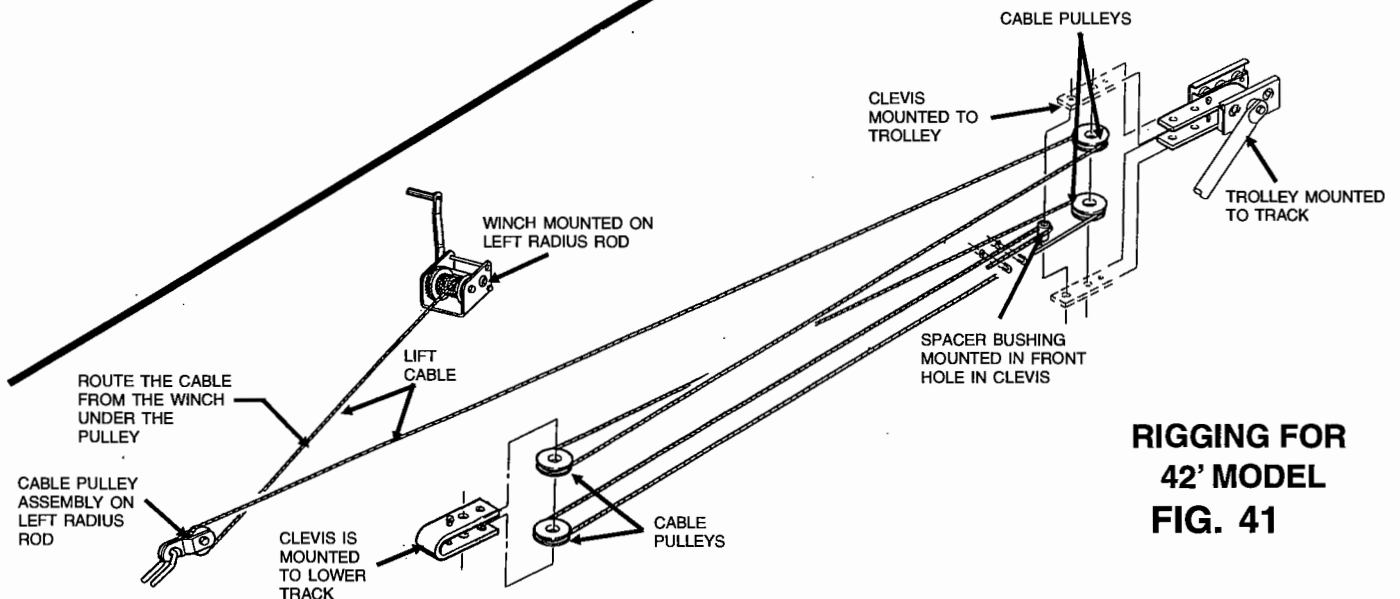
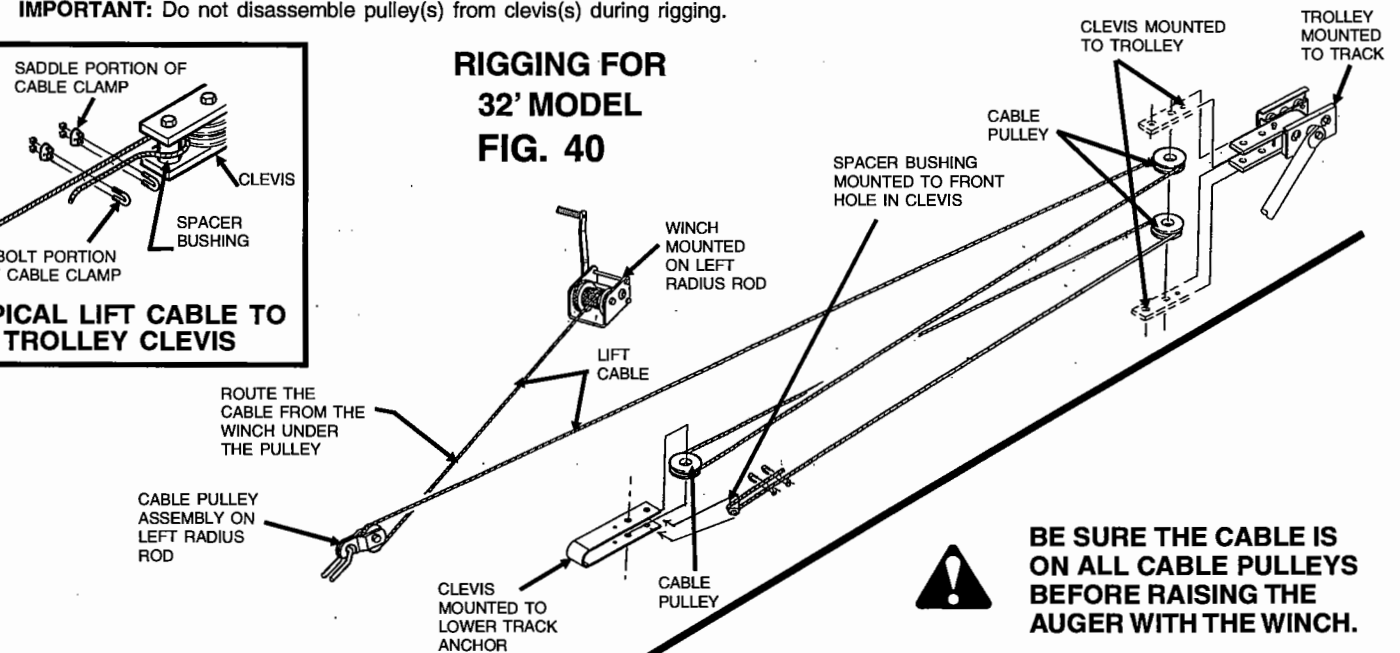

FIG. 39



RIGGING FOR 32' MODEL FIG. 40



RIGGING FOR 42' MODEL FIG. 41

ASSEMBLY INSTRUCTIONS

UNDERCARRIAGE ASSEMBLY FOR 62', 72' & 82' MODELS

The hubs, bearings, seals and spindles are assembled at the factory and are pressure packed with grease at that time.

Slide the hub and spindle assembly into the undercarriage axle and secure with 1/2" dia. (grade 5) hex head capscrew and nylon locknut. See Fig. 42. Secure tire and rim to hub with lug bolts.

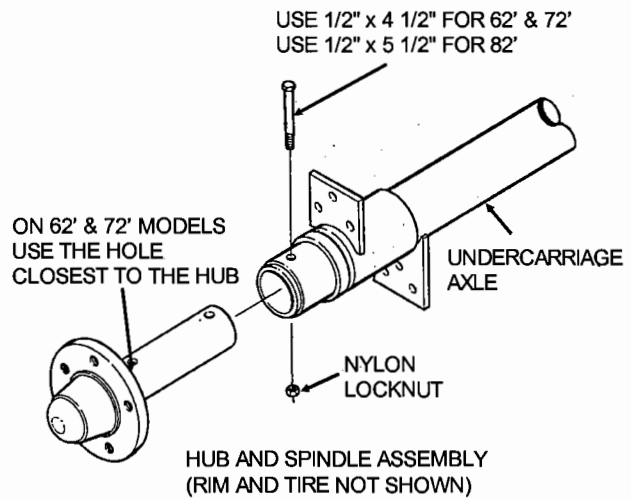

FIG. 42

UNDERCARRIAGE TO AUGER HOUSING ASSEMBLY

NOTE: See Fig. 44 on page 34 for 62' models and Fig. 45 on page 35 for 72' and 82' models.

- Step 1. Slip the 14" long bushing into the track pivot. Fasten the "H"-frame and upper frame to the pivot using a 1 1/4" dia. x 18" long HHCS through the bushing secured with a 1 1/4" nylon locknut. See Fig. 43.
- Step 2. Bolt lower frame halves together using 5/8" x 2" long hex head capscrews and nylon locknuts.. Then, fasten the upper frame to the lower frame using two 1" dia. x 3 1/8" pins and 1/4" x 2" long cotter pins.
- Step 3. Bolt the lower frame to the axle using three 1/2" x 1 1/2" long grade 5 hex head capscrews and nylon locknuts.
- Step 4. Fasten the "H"-frame tubes to the upper frame (near where the lower frame and upper frame connect). On 62' Models - the "H"-frame tube is fastened on the outside of the upper frame mounting plate with a 1" x 2 1/2" long (grade 5) hex head capscrew and a nylon locknut. On 72' and 82' Models - use a 1" x 3" long (grade 5) hex head capscrew and nylon locknut.
- Step 5. Fasten the other end of the "H"-frame tube to the "H"-frame. (Use the lower hole in the "H"-frame plate.) On 62' Models - the "H"-frame tube is fastened on the outside of the "H"-frame with a 1" x 2 1/2" long (grade 5) hex head capscrew and a nylon locknut. On 72' and 82' Models - use a 1" x 3" long (grade 5) hex head capscrew and nylon locknut.
- Step 6. Attach tube guides to the brackets welded on the upper frame using four 1/2" x 1 1/4" long (grade 5) hex head capscrews and nylon locknuts per each guide.
- Step 7. Lay out the lower arm under the auger housing. The end with the angle and one 1 1/2" dia. hole must be located near the lower mount on the auger housing. On 62' and 72' models only, the end with three 17/32" dia. holes will fasten to the axle. (See Fig. 46 on page 34.) On 82' models, the end with a bushed hole in the angle will fasten to the axle. (See Fig. 47 on page 34.)

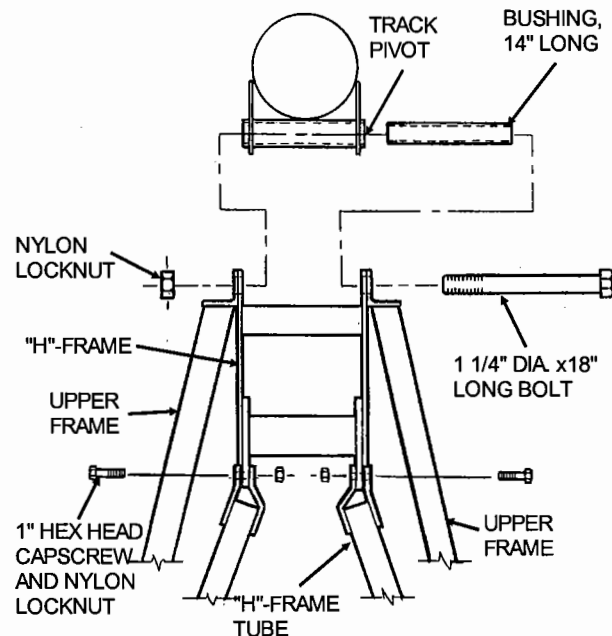

FIG. 43

ASSEMBLY INSTRUCTIONS

UNDERCARRIAGE - 62' MODELS ONLY

(Please refer also to written instructions on pages 31, 34 & 35.)

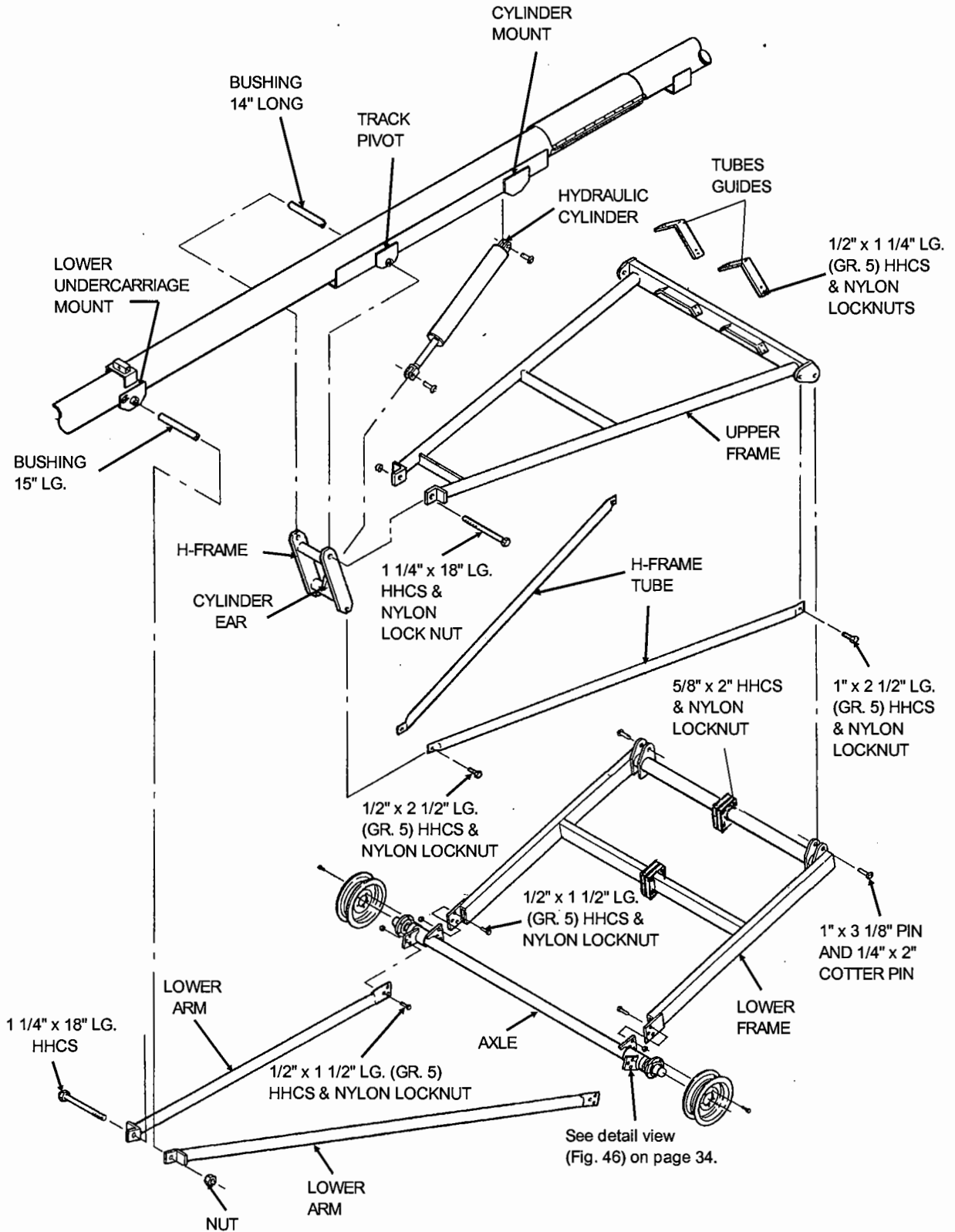

FIG. 44

ASSEMBLY INSTRUCTIONS

UNDERCARRIAGE

72' & 82' MODELS ONLY

(Please refer also to written instructions on pages 31, 34 & 35.)

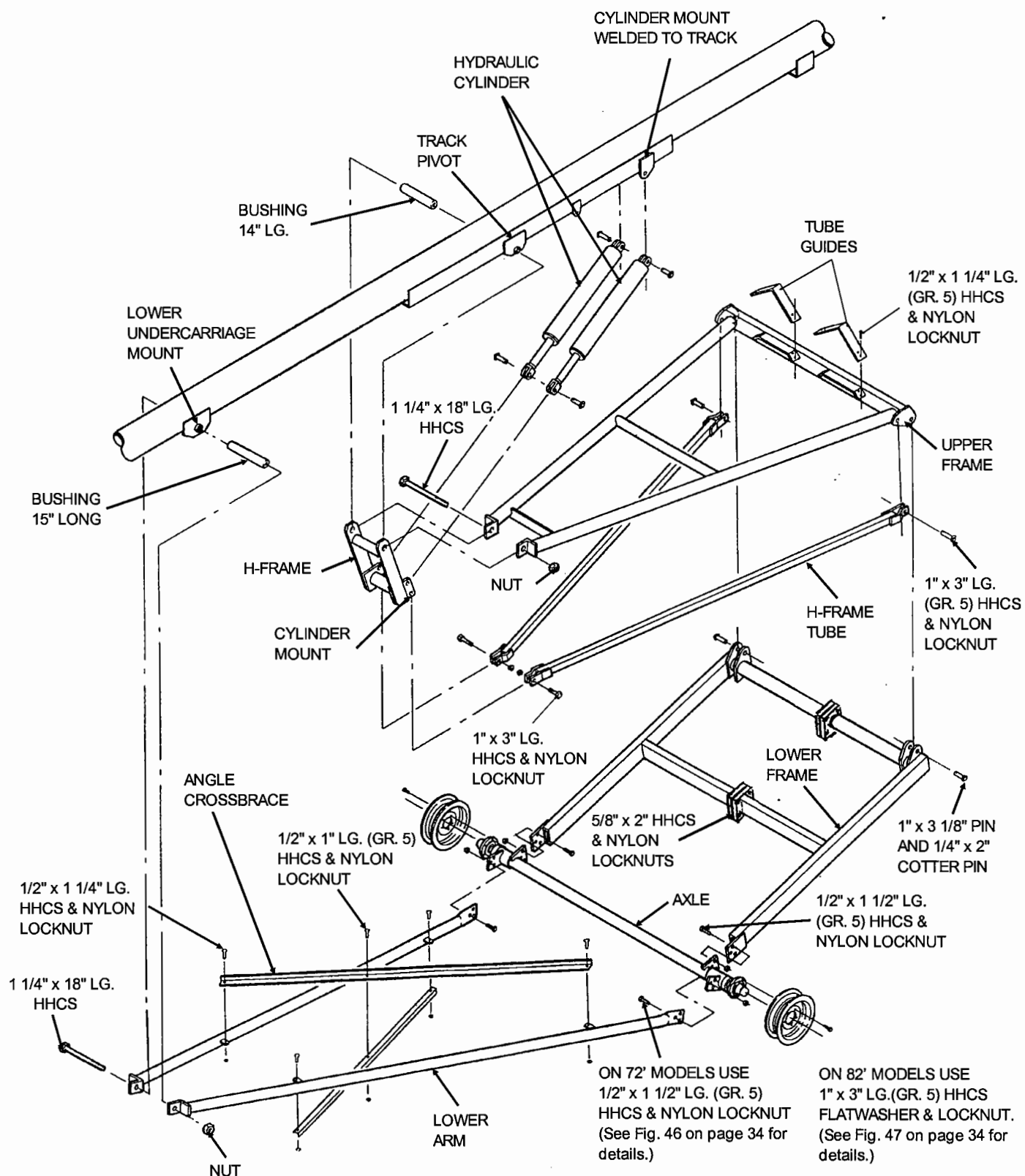

FIG. 45

ASSEMBLY INSTRUCTIONS

UNDERCARRIAGE ASSEMBLY - CONT.

Step 8. Fasten the lower arms to the axle ear brackets. On 62' and 72' models, use three 1/2" x 1 1/2" long (Grade 5) hex head capscrews and nylon locknuts for each leg. NOTE: The lower arm should be on the inside of the ear on the collar. See Fig. 46. On 82' models, use one 1" x 3" long (Grade 5) hex head capscrew, flat washer and nylon locknut for each leg. NOTE: The lower arm should be on the inside of the ear on the axle. See Fig. 47.

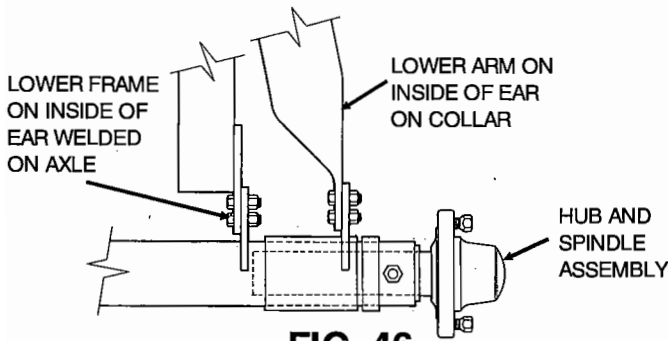

FIG. 46
62' AND 72' MODEL

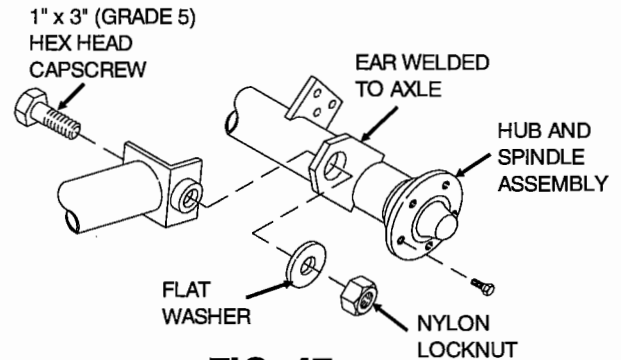

FIG. 47
82' MODEL

Step 9. On 72' & 82' models only, fasten angle crossbraces between the lower arms. Secure angles to ears on lower arm with four 1/2" x 1 1/4" long HHCS (Grade 5) and nylon locknuts. **DO NOT** tighten hardware until later. Bolt the middle of the angle crossbraces together using one 1/2" x 1" long HHCS (Grade 5) and nylon locknut. **DO NOT** tighten hardware until later.

Step 10. Wrap a chain or heavy duty strap around the auger tube and the undercarriage frame. See Fig. 48. The chain or strap must be **TIGHT** to keep the undercarriage from opening when the tube is raised.

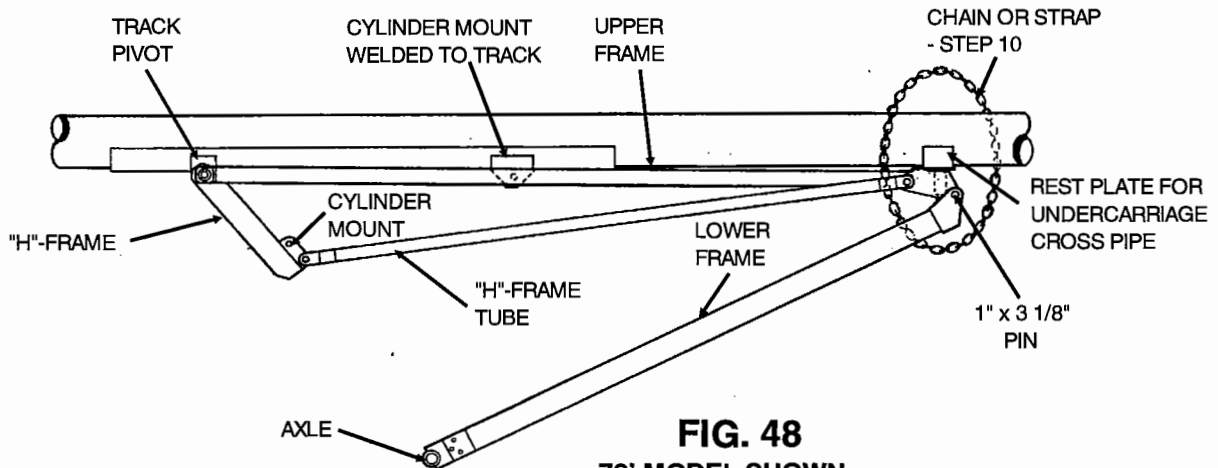

FIG. 48
72' MODEL SHOWN

Step 11. Lift the auger assembly with a hoist high enough to line up the lower arms with the lower arm mount. See Fig. 44-45. **IMPORTANT:** Only lift the auger at a point near the center of the auger with a chain hoist or other safe suitable means. **DO NOT** lift the entire weight of the auger from the extreme end.

Step 12. Slip 15" bushing into lower undercarriage mount. Fasten the lower arms to the mount using a 1 1/4" x 18" long HHCS through the bushing as shown, and a 1 1/4" nylon lock nut.

Step 13. Check to see that all undercarriage bolts and fasteners are tight, secure and assembled correctly. On 72' and 82' models, tighten all 1/2" hex head capscrews that fasten the angle crossbraces to the lower arms in Step 9. Lower the auger and release the hoist. NOTE: Remove the chain or heavy strap that was installed in Step 10.

ASSEMBLY INSTRUCTIONS

HYDRAULIC CYLINDER TO UNDERCARRIAGE INSTALLATION

Attach the hydraulic cylinder(s) to the "H"-frame using mounting pin and keeper clip furnished in box with cylinder(s). (62' Models use one cylinder. 72' and 82' Models use two cylinders.) See Figures 44 or 45 and 49. **IMPORTANT:** The base end of the cylinder must be attached to the mount on the track. The rod end of the cylinder(s) will be attached to the mount on the "H"-frame. The cylinder ports must be facing the left side of the auger when viewing the auger from the intake end. **IMPORTANT:** The cylinder(s) furnished with your auger has a restrictor in the port at the base end. This restrictor limits the speed the auger is raised or lowered. Use only cylinder(s) provided with the auger. **DO NOT** use a cylinder that does not have the proper restrictor.

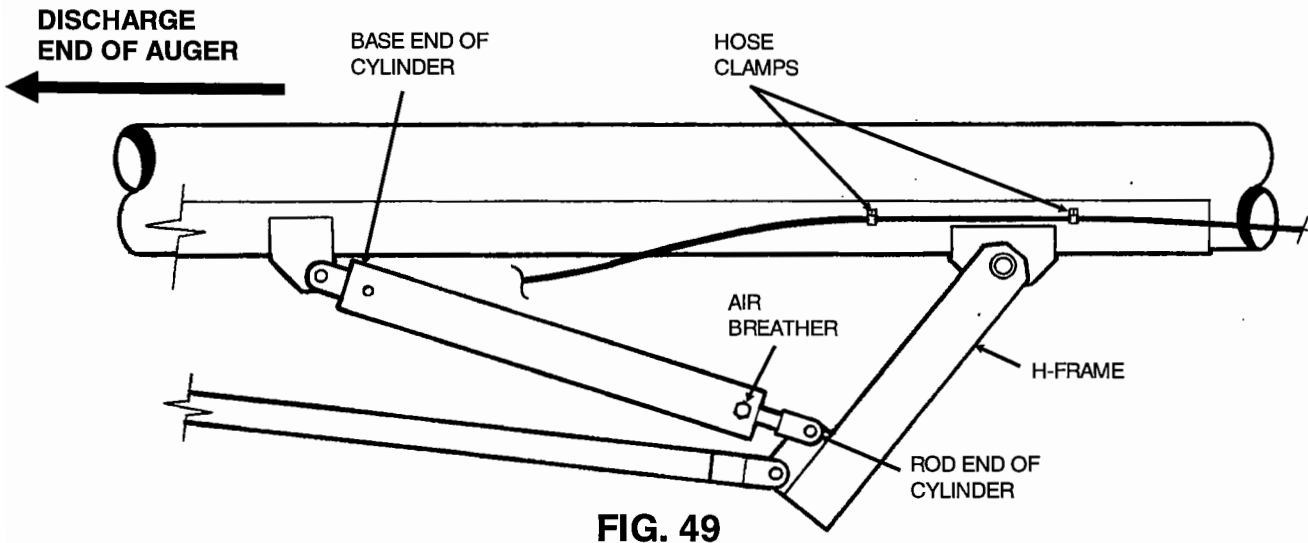

HYDRAULIC HOSE AND FITTING INSTALLATION FOR 62' MODELS

1. Thread the heavy duty street el into the upper cylinder port (at the base). Tighten and leave street el parallel with the auger tube and pointed toward inlet. See Fig. 50.
2. Attach the swivel end of the hydraulic hose to the street el and tighten.
3. Thread the female end of the shut-off valve onto the hose. When installed, the arrow on the valve must point toward the auger and away from the tractor.
4. Check all fittings and connections to see if tight.



CAUTION: Refer to HYDRAULIC COMPONENTS on page 17 before pressurizing the hydraulic system.

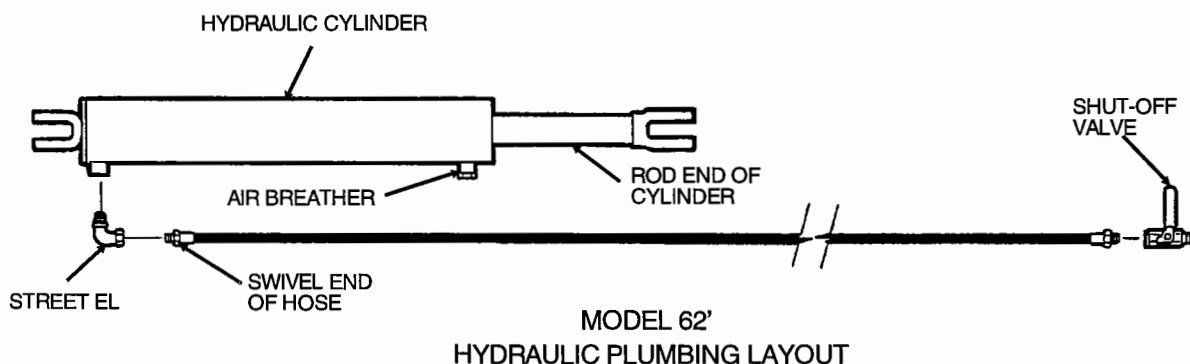

FIG. 50

ASSEMBLY INSTRUCTIONS

HYDRAULIC HOSE AND FITTING INSTALLATION FOR 72' AND 82' MODELS

- Step 1. Install the "tee" fitting into the upper cylinder port (at the base) of the cylinder mounted on the left hand side of the auger (when viewing the auger from the intake end). Tighten the "tee" so it is parallel with the cylinder body. See Fig. 51.
- Step 2. Install the **NON**-swivel end of the 18" hydraulic hose into the upper cylinder port of the other cylinder.
- Step 3. Then fasten the swivel end of the 18" long hose to the upper end of the "tee" fitting that is installed in the left hand cylinder.
- Step 4. On 72' Models attach the swivel end of the 37'-6" long hose to the other end of the "tee" fitting.
On 82' Models attach the swivel end of the 43'-6" long hose to the other end of the "tee" fitting.
- Step 5. Thread the female end of the shut-off valve onto the end of the hose. When installed, the arrow on the valve must point towards the auger and away from the tractor.
- Step 6. Check all fittings and connections to see if tight.



CAUTION: Refer to HYDRAULIC COMPONENTS on page 17 before pressurizing the hydraulic system.

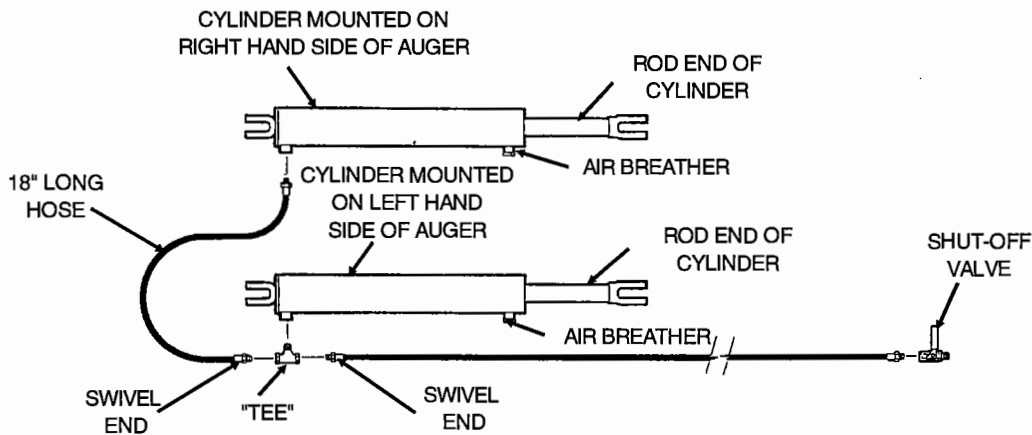

**MODEL 72' & 82'
HYDRAULIC PLUMBING LAYOUT**

FIG. 51

HYDRAULIC HOSE CLAMP INSTALLATION

Starting at the cylinder end of the hose, fasten the hydraulic hose to the track and tube housing using hose clamps and 5/16" x 3/4" hex head capscrews with lockwashers. Fig. 49 and 52.

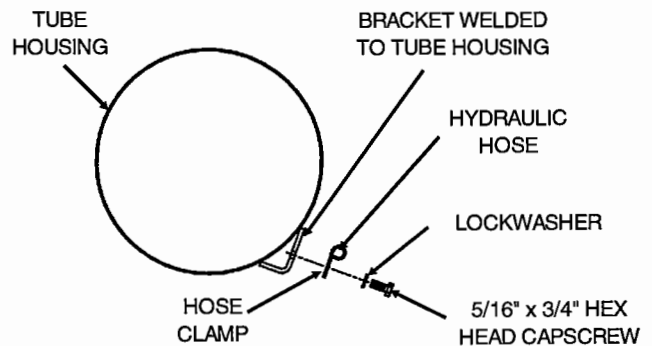

FIG. 52

ASSEMBLY INSTRUCTIONS

HITCH JACK

1. Band the jack mount tube to the auger housing using four $3/8"$ x $1\ 3/4"$ long (grade 5) hex head capscrews with locknuts. Make sure the mount tube is level. The recommended location for the mount is adjacent to the drive housing on the intake side. See Inset A. (The jack may be installed on either the right or left-hand side of the auger. Face the adjustment plate toward the side the jack will be.)
2. Slide the support tube into the mount tube on the housing. A $3/8"$ x $2\ 1/2"$ long hex head capscrew with locknut through the hole in the end of the tube will keep it from sliding out.
3. With the slotted end up, slide the square stand tube through the support tube weldment.
4. Attach the base plate to the bottom of the stand tube using a $1/2"$ x $3\ 1/2"$ long (grade 5) hex head capscrew with locknut.
5. Bolt the pulley into the stand tube using the 1" diameter spacer and a $1/2"$ x $3"$ long (grade 5) hex head capscrew with locknut.
6. Connect the winch to the support tube weldment using locknuts and flat washers with the welded studs. NOTE: Use a flat washer on both sides. (See drawing.)
7. Install the cable starting at the winch end. See Inset B. Wrap the cable once around the winch drum. Pass the short end through the hole in the drum side. Attach the cable to the outside of the drum with the keeper provided. (The cable should extend past the clamp 1".)
8. Thread the cable through the slot in the top of the stand, over the pulley and down to the eye on the support tube weldment. Secure the cable to the eye using a $3/16"$ cable clamp. The u-bolt portion of the clamp should be against the short end of the cable. Wind up excess cable onto the winch. The cable is properly attached to the winch when there is a clicking sound as the cable is being wound onto the winch drum. There should be at least three complete wraps of cable on the drum when the support tube weldment is in transport position (at the bottom of the stand tube). See winch operating instructions under "Hitching to Tractor" on pages 4 and 5.
9. Rotate the stand until it is approximately vertical. Use a $1/2"$ x $1"$ long (grade 5) hex head capscrew with locknut through the adjustment plates to hold it in position.
10. Install a $1/2"$ x $3\ 1/8"$ long washer head pin in the stand and secure it with the hair pin clip. See Fig. 3.

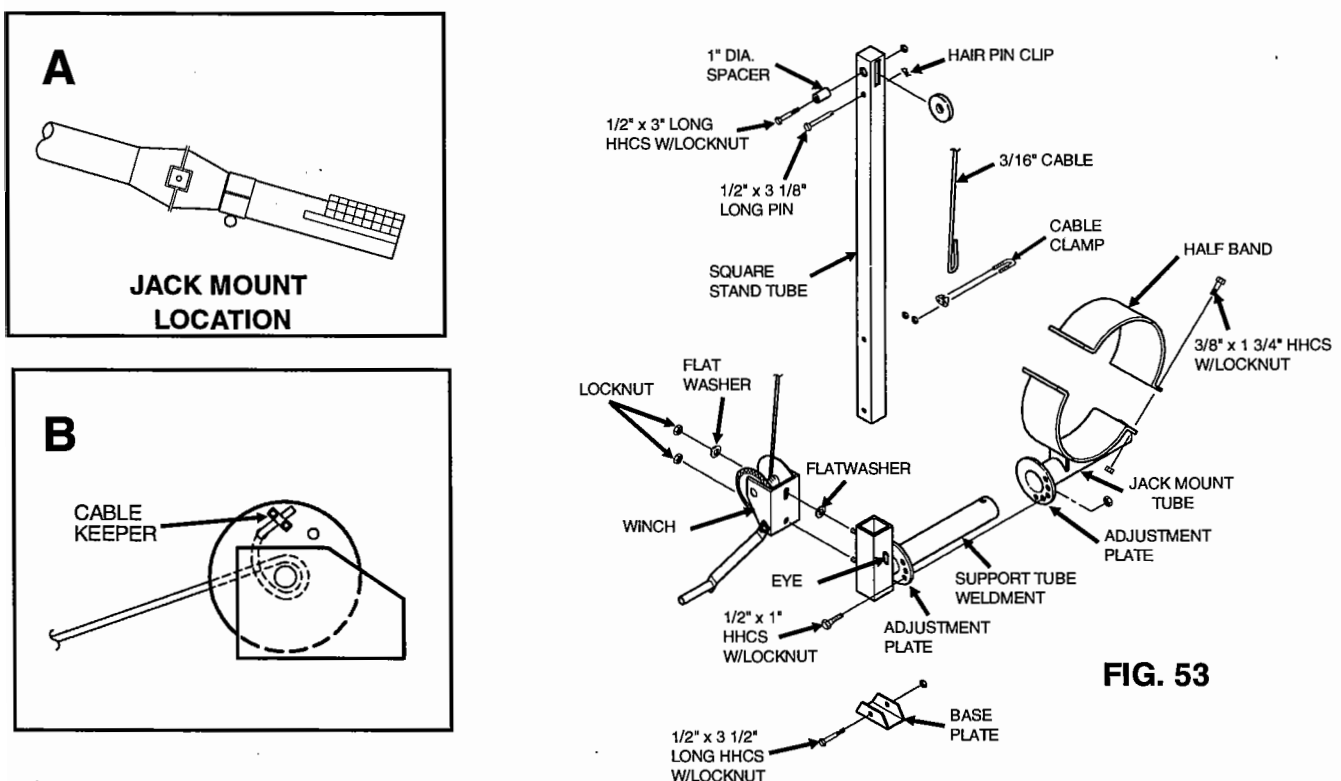

FIG. 53

ASSEMBLY INSTRUCTIONS

DRAIN HOLE COVER

Install drain hole cover using two 5/16" x 3/4" long carriage bolts with a lock nut for the pivot hole and a wing nut for the slot. See Fig. 54.

HITCH

Attach hitch to tube attachment anchor with one 1/2" x 3 1/2" long (grade 5), hex head capscrew, lockwasher and nut. See Fig. 54.

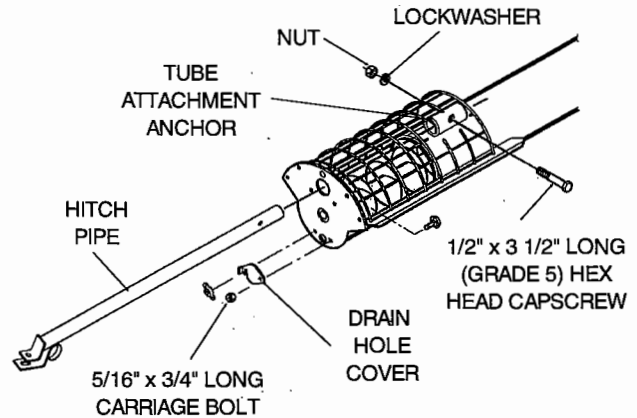

FIG. 54

BLOW-OFF CAP

- Step 1. Attach chain to the hole in the top of the tube, located at the discharge end of the auger using a 1/4" x 3/4" long hex head capscrew and 1/4" nylon locknut.
- Step 2. Attach the other end of the chain into the hole of the cap using a 1/4" x 3/4" long hex head capscrew and 1/4" nylon locknut.
- Step 3. Slide cap over end of tube. The cap should fit snugly, but be able to slide off the end of the tube if discharge should become plugged. Push the cap off to verify fit and then reinstall. It should be possible to tap the cap off by hand.

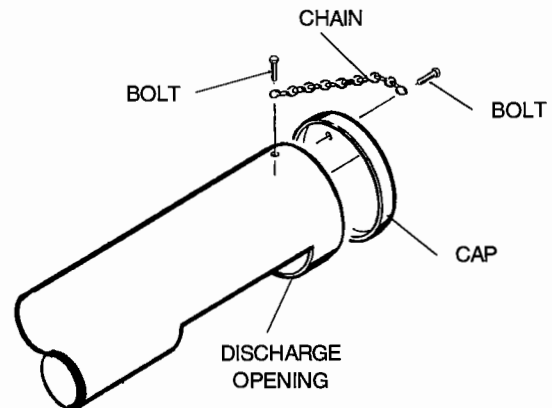

FIG. 55

OPERATOR'S MANUAL CONTAINER

1. Check that an Operator's Manual is in the plastic container.
2. Snap the container into holder located on the drive housing.

ASSEMBLY INSTRUCTIONS

ELECTRIC MOTOR DRIVE

NOTE: The gearbox input shaft must be located on the right hand side of the auger housing for the electric drive to be assembled. Refer to Fig. 57.

- Step 1. Fasten end of motor mount frame to bracket welded to drive housing with four 1/2" x 1 1/2" long (grade 5) hex head capscrews and nylon locknuts.
- Step 2. Attach other end of motor mount frame to welded bracket on auger tube with 1/2" x 1 1/2" long (grade 5) hex head capscrews and nylon locknuts.
- Step 3. Fasten belt guard brackets to the drive housing flange using the flange bolts which are already in place.
- Step 4. Attach belt guard to brackets with four 5/16" x 3/4" long (grade 5) hex head capscrews, double flat washers and nylon locknuts. Attach belt guard to motor mount with four 5/16" x 1" long (grade 5) hex head capscrews, double flat washers and locknuts.
- Step 5. Install motor. It is important to use the recommended size and speed. See page 13 for specifications.

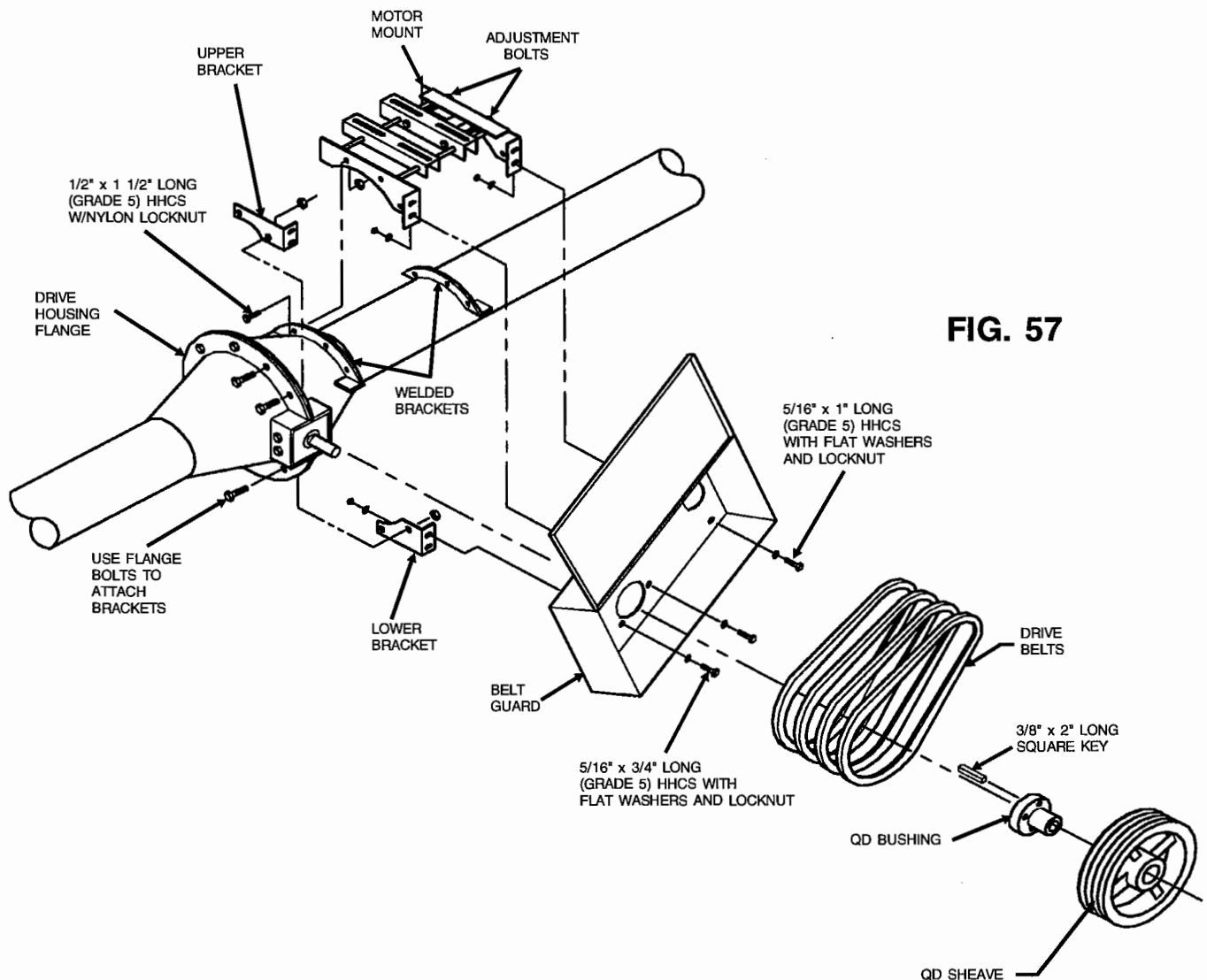

FIG. 57

ASSEMBLY INSTRUCTIONS

ELECTRIC MOTOR DRIVE - CONT.

Step 6. Install the sheave on the motor shaft. A 5" O.D. sheave is recommended for a flight speed of 475 RPM. Other sizes can be used to vary the flight speed. Please refer to page 10 for minimum and maximum recommended operating speeds.

Step 7. Assemble the QD taper lock bushing to the 15" O.D. sheave. Install the sheave assembly to the gearbox shaft with a 3/8" square 2" long key. Tighten setscrews.

Step 8. Align the sheaves to each other by placing a straight edge across the outer faces of both.

Step 9. Install and tighten belts. Use the adjustment bolts in the end of the motor mount. Adjustment bolts should be turned equally to prevent binding.

P.T.O. DRIVE

The PTO drive can be installed on either the right or left hand side of the auger.



Care should be taken when changing a PTO drive from one side of the auger to the other. To avoid dangerous situations, follow changeover instructions on page 42.

Step 1. Attach PTO driveline to gearbox input shaft by using 3/8" x 1 1/2" long square drive key. See Fig. 59 on the following page. Place setscrews properly, then tighten. See Fig 58.

IMPORTANT: For the setscrews in the PTO driveline yoke to be properly engaged on the input shaft, one setscrew will sit on the flat portion of the shaft and the other setscrew on the 3/8" x 1 1/2" lg. key. **DO NOT** extend the input shaft beyond the inside end of the yoke. See Fig. 58.

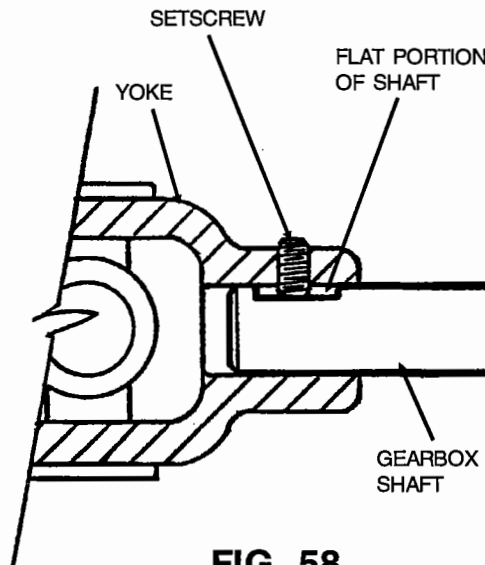

ASSEMBLY INSTRUCTIONS

PTO DRIVE - CONT.

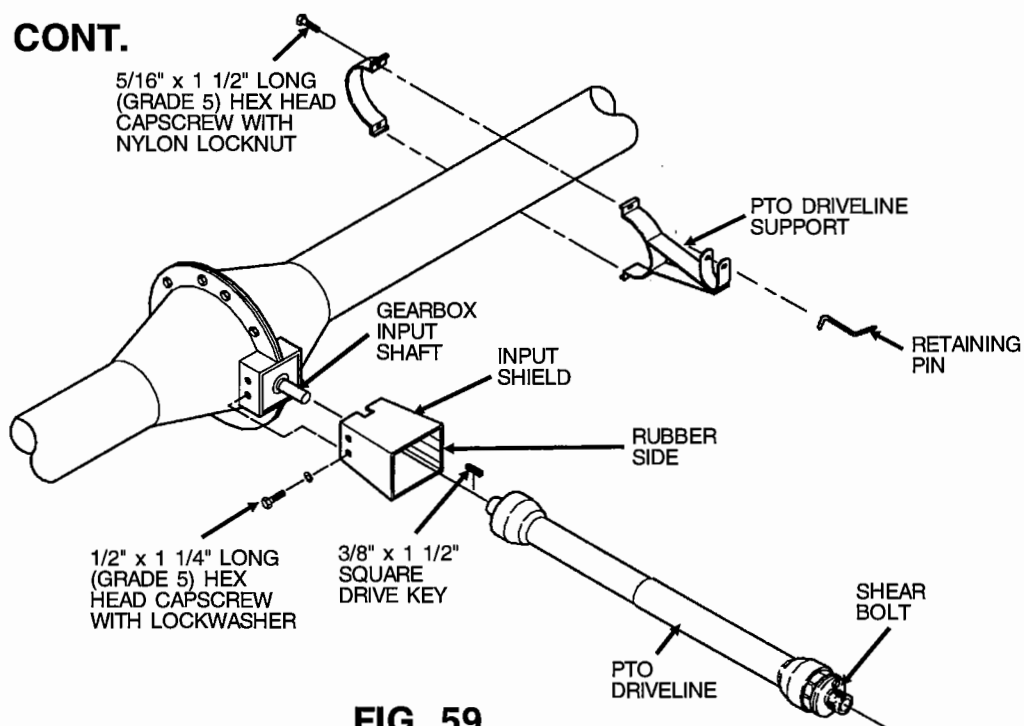

FIG. 59

- Step 2. Remove two 1/2" x 1" long (grade 5) hex head capscrew that hold gearbox mounting ear to drive housing.
- Step 3. Slide input shield over the PTO driveline and fasten to the drive housing using two 1/2" x 1 1/4" long (grade 5) hex head capscrews with lockwashers. See Fig. 59.
NOTE: Locate the rubber side of the the input shield so the PTO driveline can be swung towards the discharge end of the auger for storage during transport as shown in Fig. 60.
- Step 4. Place the PTO driveline support 51" from the center of the gearbox (toward the discharge end of the auger). Secure the support to the tube with a halfband and two 5/16" x 1 1/2" long (grade 5) hex head capscrews and nylon locknuts.
IMPORTANT: Do not install the support where the bands will cover any safety signs on the auger housing.
- Step 5. Set PTO driveline into the support to be sure the support is installed properly.
- Step 6. Install the retaining pin by slipping the short bend end of pin through hole in PTO driveline support and through slot on the other side. Allow long end of pin to rotate down, this will secure pin in place.

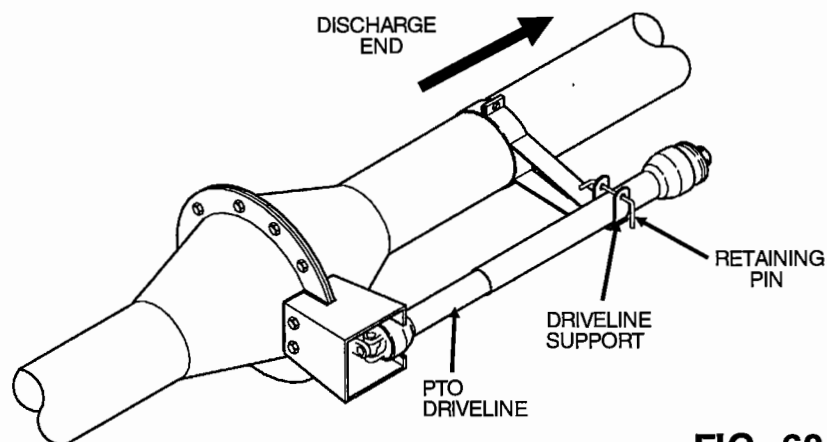

FIG. 60

PTO DRIVE CHANGEOVER INSTRUCTIONS

- Step 1. Disconnect PTO driveline from tractor.
- Step 2. Remove the input shield from drive housing.
- Step 3. Follow the drive housing disassembly instructions, so gearbox can be unbolted from the drive housing halves.
- Step 4. Slide the drive housing apart so gearbox can be rotated 180°. You do not need to disconnect flight from gearbox.
- Step 5. The filler/vent elbow on the gearbox mounting ear must be rotated so it is pointing up.
- Step 6. Bolt gearbox to drive housing halves and the drive housing flanges together.
- Step 7. Install the input shield to cover the PTO driveline to gearbox shaft connection. See Fig. 59 on page 41.
- Step 8. Remount the PTO driveline support onto the other side of the tube. See Fig. 59 on page 41.

DRIVE HOUSING DISASSEMBLY INSTRUCTIONS

Care should be taken if the drive housing must be disassembled to repair the gearbox and flight or to change drive from one side of the auger to the other side of the auger.

- Step 1. Disconnect power source from the auger.
- Step 2. Auger must be in full down transport position.
On 32' & 42' Models - The trolley seated against the down stop.
On 62', 72' & 82' Models - The auger tube seated on the undercarriage crossbrace.
- Step 3. Support the discharge end of auger, either with overhead hoist to hold the auger up or a suitable structure under the auger to prevent the auger from upending when drive housing is disassembled and intake end of auger housing is removed.
- Step 4. Block just above the drive housing so the intake end is 4" to 6" above the ground.
- Step 5. Disassemble drive housing halves to gain access to gearbox and flight.
- Step 6. **IMPORTANT:** Be sure the auger is completely reassembled before removing any supports.

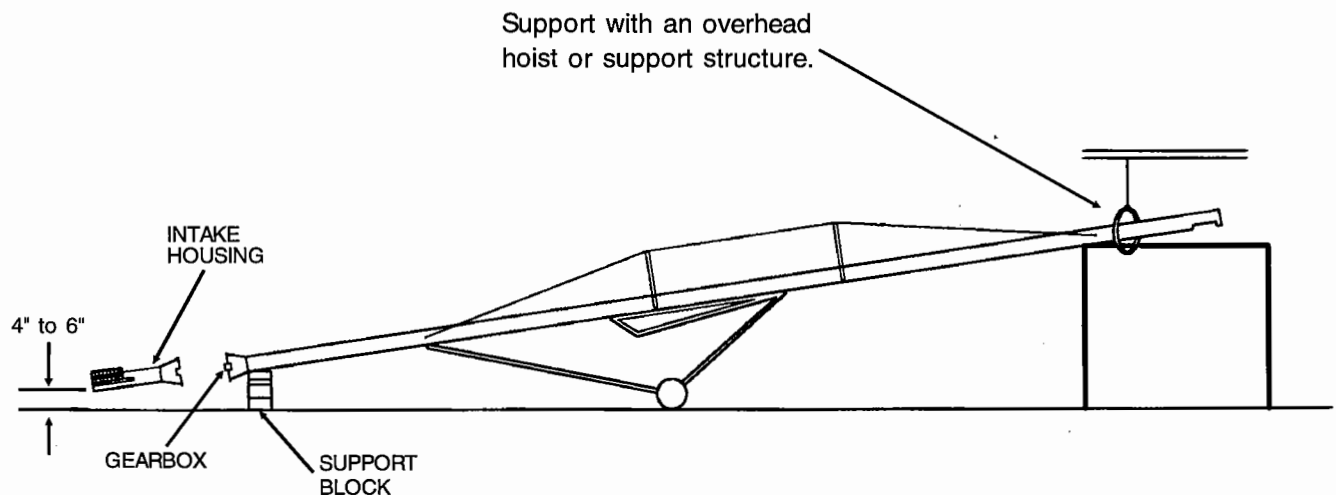

FIG. 61

NOTICE TO DEALER/ASSEMBLER

The assembly of the auger is complete if all the applicable assembly steps in this manual have been followed.

Before delivery to the owner it is a good practice to check the following:

- a. Be sure all safety shields and devices are installed properly.
- b. Check all safety decals to see if they are clean and readable. If any are missing, damaged, painted over, etc. replace them. See page P-1 for safety sign location. Decals may be obtained from your dealer or ordered from the factory.
- c. Check all bolts and fasteners to see they are tightened and secured properly.
- d. Check that the operator's manual container (with operator's manual inside) is installed in its holder located on the drive gearbox housing.

Deliver this Assembly and Operator's Manual to the owner along with the auger.

12" INLINE/MID-DRIVE

Page P-1

SAFETY SIGNS AND DECALS

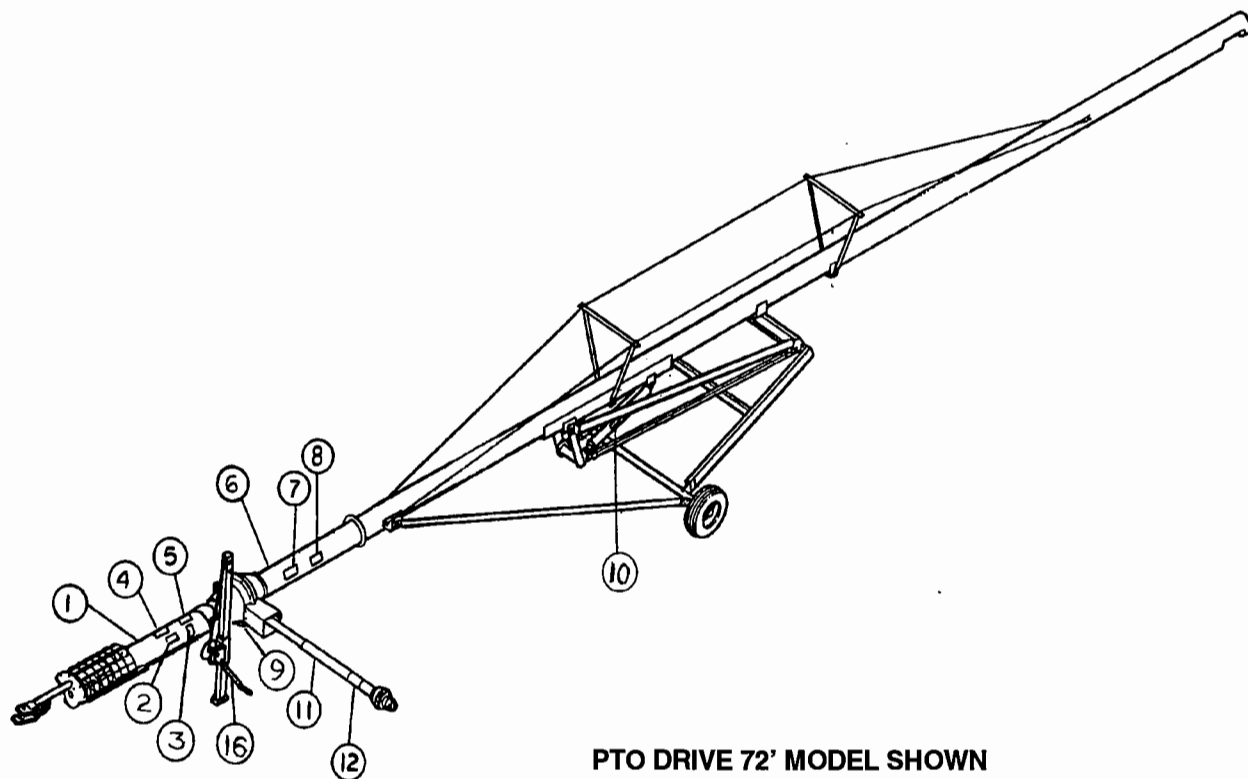

PTO DRIVE 72' MODEL SHOWN

REF. NO.	PART NO.	DESCRIPTION	SIZE
1	1001973	CAUTION - GENERAL STATEMENTS 1-8 DECAL	4 3/4" x 8"
2	1001980	DANGER - BEWARE OF POWER LINES DECAL	4" x 8"
3	1001983	DANGER - ROTATING DRIVE LINE DECAL	4 1/2" x 6 1/4"
4	1001985	DANGER - ROTATING AUGER DECAL	4 1/2" x 6 1/4"
5	1001981	DANGER - UPENDING HAZARD DECAL	4 1/2" x 6 1/4"
6	1001974	WARNING - ESCAPING HYDRAULIC OIL DECAL	4" x 7 1/4"
7	1001984	DANGER - DISASSEMBLY HAZARD DECAL	4" x 6"
8	1005324	DANGER "STOP" IF ANY GUARDS, SHIELDS	4" x 6"
9	1004461	OPERATOR'S MANUAL INSIDE DECAL On Operator's Manual Container	1 1/2" x 7 1/2"
10	1001926	DANGER - CYLINDER	--
11	13-10022	DANGER - SHIELD MISSING Under PTO Driveline Shield	--
12	13-10021	DANGER - ROTATING DRIVELINE On PTO Driveline Shield	--
13	1002805	CAUTION - CABLE OUT/CABLE IN On Winch Body - 42' Undercarriage	--
14	2169A1	CAUTION - WINCH OPERATION On Hand Winch Handle - 42' Undercarriage	--
15	1002091	WARNING HAND WINCH OPERATION (42' units)	2 3/4" x 5"
16	1016296	CAUTION - SPINNING WINCH HANDLE	3/4" x 2 1/2"

SAFETY SIGNS AND DECALS

The safety sign locations and part numbers are shown on page P-1. Safety signs may be obtained from your dealer or ordered from the factory.

⚠ DANGER



ROTATING DRIVELINE

- KEEP BODY, HAIR AND CLOTHING AWAY FROM ROTATING DRIVELINE.
- USE ONLY WITH AGRICULTURAL TRACTOR HAVING AN RPM POWER TAKE OFF.
- KEEP ALL DRIVELINE, TRACTOR AND EQUIPMENT GUARDS IN PLACE.
- MAKE SURE DRIVELINES ARE SECURELY ATTACHED AT BOTH ENDS.
- MAKE SURE DRIVELINE SHIELDS TURN FREELY ON DRIVELINE.
- KEEP LOCKOUT ANGLES SMALL AND EQUAL.
- KEEP CHILDREN WELL CLEAR OF WORK AREA.

FAILURE TO HEED WILL RESULT IN SERIOUS INJURY OR DEATH!

⚠ DANGER



ROTATING AUGER

- KEEP HANDS, FEET, HAIR AND CLOTHING AWAY FROM ROTATING AUGER.
- DO NOT REMOVE OR MODIFY ANY GUARDS.
- KEEP CHILDREN WELL CLEAR OF WORK AREA.

FAILURE TO HEED WILL RESULT IN SERIOUS INJURY OR DEATH!

⚠ DANGER



UPENDING HAZARD

- SUPPORT DISCHARGE END OR ANCHOR INTAKE END TO PREVENT UPENDING.
- EMPTY MACHINE BEFORE MOVING.
- DO NOT PUSH THE UNDERCARRIAGE BY HAND.
- LIFT THE INTAKE END SLOWLY AND NEVER HIGHER THAN VEHICLE TOW BAR. MAINTAIN CONTROL UNTIL SECURELY ATTACHED TO TOW BAR OR RESTING ON THE GROUND.
- LOWER TO TRANSPORT POSITION IMMEDIATELY WHEN CLEAR FROM GRAIN STORAGE STRUCTURE.

FAILURE TO HEED WILL RESULT IN SERIOUS INJURY OR DEATH!

⚠ WARNING



- ESCAPING HYDRAULIC OIL UNDER PRESSURE WILL CAUSE SERIOUS INJURY IF IT PENETRATES THE SKIN. SEE A DOCTOR IMMEDIATELY IF INJURED.
- USE METAL OR WOOD AS A BACKSTOP WHEN SEARCHING FOR HYDRAULIC LEAKS.
- RELIEVE HYDRAULIC PRESSURE BEFORE DISCONNECTING HYDRAULIC LINES.
- FREQUENT INSPECTION AND MAINTENANCE OF THE HYDRAULIC SYSTEM IS REQUIRED. SEE OWNER'S/ OPERATOR'S MANUAL.

FAILURE TO HEED WILL RESULT IN SERIOUS INJURY OR DEATH!

⚠ DANGER



**BEWARE OF POWER LINES
ELECTROCUTION HAZARD**

- THIS MACHINE IS NOT INSULATED.
- KEEP AT LEAST 10 FEET AWAY FROM OVERHEAD ELECTRICAL WIRES.
- ELECTROCUTION CAN OCCUR WITHOUT DIRECT CONTACT.

FAILURE TO HEED WILL RESULT IN SERIOUS INJURY OR DEATH!

⚠ DANGER



IF ANY GUARDS, SHIELDS OR SAFETY DECALS ARE DAMAGED OR MISSING, ORDER FREE REPLACEMENTS BY CALLING

1-800-523-6993
OR WRITE TO:
HUTCHINSON/MAYRATH
P.O. BOX 829
CLAY CENTER, KANSAS 67432

⚠ WARNING



ROTATING DRIVELINE

- AFTER EACH STOP, ALWAYS STOP THE TRACTOR AND LOCKOUT THE PTO. MAKE SURE THE DRIVELINE IS COMPLETELY STOPPED BEFORE ATTEMPTING TO SERVICE ANY PARTS.
- DO NOT PLAY WITH ANY PARTS OF THE DRIVE SHAFT.
- NEVER TOUCH OR REPAIR ANY PARTS OF THE DRIVE SHAFT OR PTO WHILE THE TRACTOR IS RUNNING.
- ALWAYS WEAR YOUR SEATBELT WHEN OPERATING THE TRACTOR.

FAILURE TO HEED WILL RESULT IN SERIOUS INJURY OR DEATH!

⚠ DANGER



**ROTATING DRIVELINE
CONTACT CAN CAUSE DEATH
KEEP AWAY!**

DO NOT OPERATE WITHOUT —

- ALL DRIVELINE, TRACTOR AND EQUIPMENT SHIELDS IN PLACE
- DRIVELINES SECURELY ATTACHED AT BOTH ENDS
- DRIVELINE SHIELDS THAT TURN FREELY ON DRIVELINE

⚠ DANGER



**SHIELD MISSING
DO NOT OPERATE**

⚠ DANGER



**SHIELD MISSING
DO NOT OPERATE**

⚠ DANGER

OPERATOR'S MANUAL INSIDE **OPERATOR'S MANUAL INSIDE** **OPERATOR'S MANUAL INSIDE**

⚠ CAUTION

1. READ AND UNDERSTAND THE OPERATOR'S MANUAL BEFORE OPERATING.
2. DO NOT REMOVE OR MODIFY ANY GUARDS.
3. MAKE CERTAIN EVERYONE IS CLEAR BEFORE OPERATING OR MOVING THE MACHINE.
4. KEEP HANDS, FEET, HAIR AND CLOTHING AWAY FROM MOVING PARTS.
5. STOP MACHINE AND LOCKOUT POWER TO ADJUST, SERVICE OR CLEAN.
6. STOP MACHINE AND LOWER TO TRANSPORT POSITION FOR TRANSPORTING.
7. DO NOT ATTEMPT TO MOVE MACHINE MANUALLY. USE A TOWING VEHICLE.
8. KEEP CHILDREN WELL CLEAR OF WORK AREA.

⚠ DANGER



⚠ DANGER

- THIS CYLINDER IS DESIGNED FOR THE BUREAU OF ARMY AIRBORNE ONLY.
- BEFORE EACH USE INSPECT CYLINDER, LINE, HOSES AND TUBING FOR LEAKS, WEAR OR DAMAGE. REPLACE TUBING OR DAMAGED PARTS IMMEDIATELY.
- ANY LOSS OF PRESSURE WILL ALLOW THE AUGER TO LOWER WITHOUT WARNING.
- DO NOT LEAVE CYLINDER.
- FREQUENT INSPECTION AND MAINTENANCE OF THIS HYDRAULIC SYSTEM IS REQUIRED. SEE OPERATOR'S/OWNER'S MANUAL.

FAILURE TO HEED WILL RESULT IN SERIOUS INJURY OR DEATH!

⚠ DANGER



⚠ DANGER

DO NOT ATTEMPT UNASSISTEDLY BEFORE SUPPORTING THE AUGER WITH AN OVERHEAD HOIST OR OTHER SAFE, SUITABLE MEANS. THE AUGER MAY COLLAPSE WHILE LOCKING A COMPONENT IF NOT SUPPORTED.

FAILURE TO HEED WILL RESULT IN SERIOUS INJURY OR DEATH!

12" INLINE/MID-DRIVE

MAIN AUGER COMPONENTS

32'

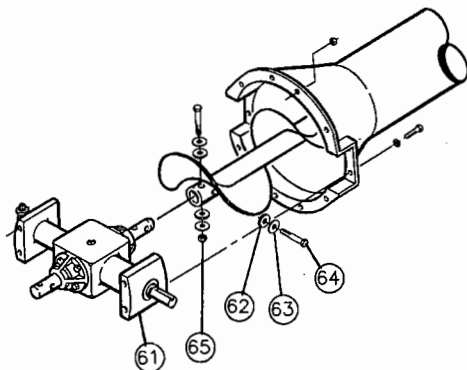
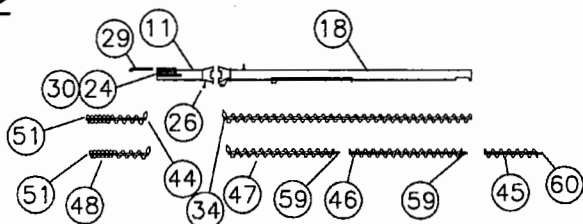

42'

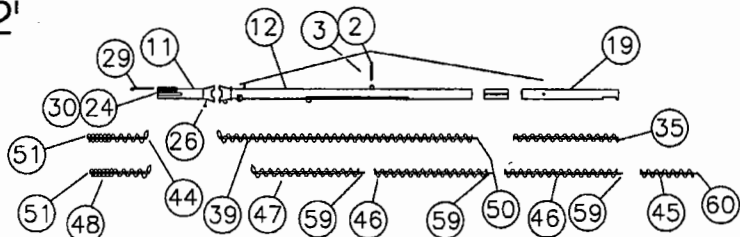

62'

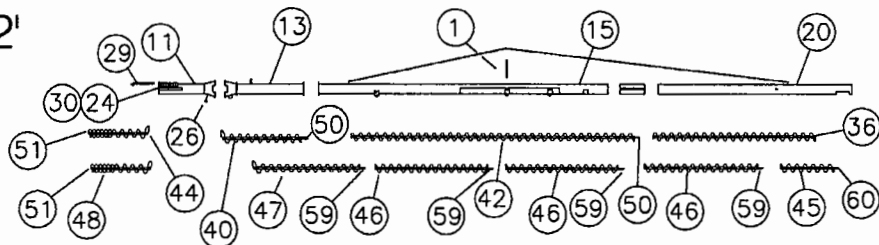

72'

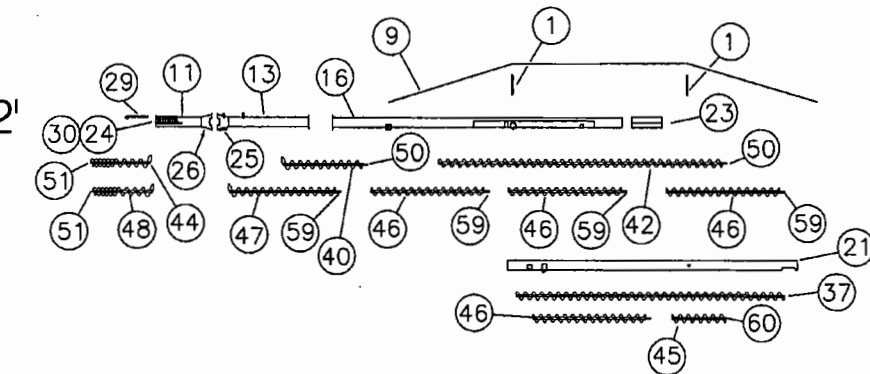

82'

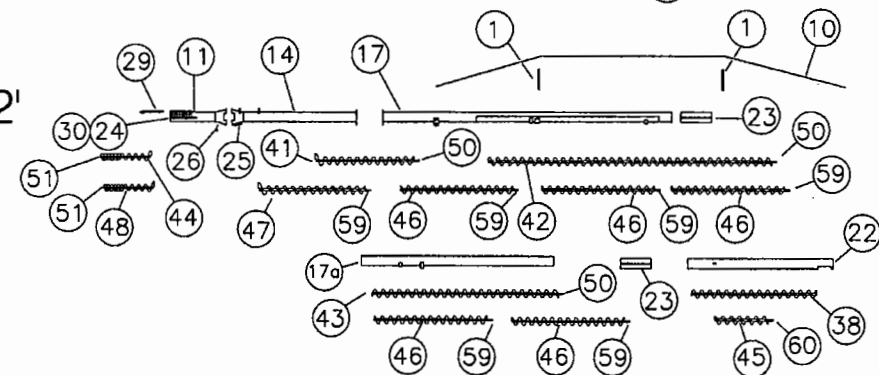

12" INLINE/MID-DRIVE

MAIN AUGER COMPONENTS

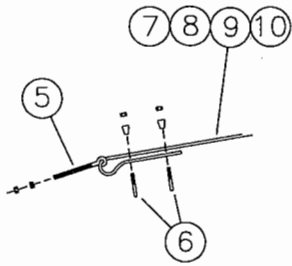

DETAIL A

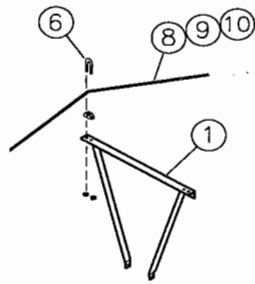

62', 72' & 82'

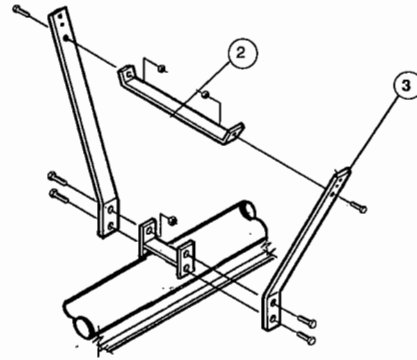

42'

REF. NO.	PART NO.	DESCRIPTION
1	1010452	Truss Frame, 62', 72' & 82'
2	106399	Truss Crossbrace, 42'
3	106398	Truss Side, 42'
4		Truss Mount 42'
5	866015-1	Eyebolt, 5/8" dia.

REF. NO.	PART NO.	DESCRIPTION
6	3010L11	Cable Clamp, 3/8"
7	1017956	Cable, 5/16" x 30' lg. 1/42'
8	1010611	Cable, 3/8" x 42' lg. 1/62'
9	1010554	Cable, 3/8" x 50' lg. 1/72'
10	552813	Cable, 3/8" x 53' lg. 1/82'

GALVANIZED HOUSINGS

REF. NO.	PART NO.	DESCRIPTION
11	1013421-130	Tube Housing - Lower w/Intake Guard
12-14	---	Tube Housing - Center
12	1018071-230	1/42' (26'-3" lg.) - Hutchinson
	1018071-330	1/42' (26'-3" lg.) - Mayrath
13	1018072-130	1/62' & 72' (6'-3" lg.)
14	1018072-130	1/82' (11'-3" lg.)
15-18	---	Tube Housing - Middle
15	1017968-130	1/62' (flanged) (30' lg.)
16	1015859-130	1/72' (flanged) (30' lg.)
17	1015966-130	1/82' (flanged) (30' lg.)
17A	1015967-230	1/82' (no flange) (20' lg.) - Hutchinson
	1015967-330	1/82' (no flange) (20' lg.) - Mayrath
18-22	---	Tube Housing - Upper
18	1018070-230	1/32' (26'-4" lg.) - Hutchinson
	1018070-330	1/32' (26'-4" lg.) - Mayrath
19	1016225-130	1/42' (10' lg.)
20	1017970-230	1/62' (20' lg.) - Hutchinson
	1017970-330	1/62' (20' lg.) - Mayrath
21	1015860-330	1/72' (30' long) - Hutchinson
	1015860-230	1/72' (30' lg.) - Mayrath
22	1015968-130	1/82' (15' lg.)

POWDER COATED HOUSINGS

REF. NO.	PART NO.	DESCRIPTION
11	1013421-130	Tube Housing - Lower w/Intake Guard
12-14	---	Tube Housing - Center
12	1018071-270	1/42' (26'-3" lg.) - Hutchinson
	1018071-370	1/42' (26'-3" lg.) - Mayrath
13	1018072-170	1/62' & 72' (6'-3" lg.)
14	1018073-170	1/82' (11'-3" long)
15-18	---	Tube Housing - Middle
15	1017968-170	1/62' (flanged) (30' lg.)
16	1015859-170	1/72' (flanged) (30' lg.)
17	1015966-170	1/82' (flanged) (30' lg.)
17A	1015967-270	1/82' (no flange) (20' lg.) - Hutchinson
	1015967-370	1/82' (no flange) (20' lg.) - Mayrath
18-22	---	Tube Housing - Upper
18	1018070-270	1/32' lg. (26'-4" lg.) - Hutchinson
	1018070-370	1/32' lg. (26'-4" lg.) - Mayrath
19	1016225-170	1/42' (10' lg.)
20	1017970-270	1/62' (20' lg.) - Hutchinson
	1017970-370	1/62' (20' lg.) - Mayrath
21	1015860-270	1/72' (30' lg.) - Hutchinson
	1015860-370	1/72' (30' lg.) - Mayrath
22	1015968-170	1/82' (15' lg.)

GALVANIZED HOUSINGS FOR INTERMEDIATE BEARINGS

REF. NO.	PART NO.	DESCRIPTION
11	1013421-130	Tube Housing - Lower w/Intake Guard
12-14	---	Tube Housing - Center
12	1016227-230	1/42' (26'-3" lg.) - Hutchinson
	1016227-330	1/42' (26'-3" lg.) - Mayrath
13	1018074-130	1/62' & 72' (6'-3" lg.)
14	1018075-130	1/82' (11'-3" lg.)
15-18	---	Tube Housing - Middle
15	1017969-130	1/62' (flanged) (30' lg.)
16	1016232-130	1/72' (flanged) (30' lg.)
17	1016235-130	1/82' (flanged) (30' lg.)
17A	1016246-230	1/82' (no flange) (20' lg.) - Hutchinson
	1016236-330	1/82' (no flange) (20' lg.) - Mayrath
18-22	---	Tube Housing - Upper
18	1022457-230	1/32' (26'-4" lg.) - Hutchinson
	1022457-330	1/32' (26'-4" lg.) - Mayrath
19	1016228-130	1/42' (10' lg.)
20	1017971-230	1/62' (20' lg.) - Hutchinson
	1017971-330	1/62' (20' lg.) - Mayrath
21	1016233-230	1/72' (30' lg.) - Hutchinson
	1016233-330	1/72' (30' lg.) - Mayrath
22	1016237-130	1/82' (15' lg.)
61	1009652	12" In-Line Gearbox
62	1022476	5/8" Neoprene Washer
63	---	5/8" Washer
64	---	5/8" x 4 1/2" HHCS (grade 8)
65	----	5/8" Side Depress Lock Nut

POWDER COATED HOUSINGS FOR INTERMEDIATE BEARINGS

REF. NO.	PART NO.	DESCRIPTION
11	1013421-130	Tube Housing - Lower w/Intake Guard
12-14	---	Tube Housing - Center
12	1016227-270	1/42' (26'-3" lg.) - Hutchinson
	1016227-370	1/42' (26'-3" lg.) - Mayrath
13	1018074-170	1/62' & 72' (6'-3" lg.)
14	1018075-170	1/82' (11'-3" lg.)
15-18	---	Tube Housing - Middle
15	1017969-170	1/62' (flanged) (30' lg.)
16	1016232-170	1/72' (flanged) (30' lg.)
17	1016235-170	1/82' (flanged) (30' lg.)
17A	1016236-270	1/82' (no flange) (20' lg.) - Hutchinson
	1016236-370	1/82' (no flange) (20' lg.) - Mayrath
18-22	---	Tube Housing - Upper
18	1022457-270	1/32' (26'-4" lg.) - Hutchinson
	1022457-370	1/32' (26'-4" lg.) - Mayrath
19	1016228-170	1/42' (10' lg.)
20	1017971-270	1/62' (20' lg.) - Hutchinson
	1016233-270	1/72' (30' lg.) - Mayrath
21	1016233-270	1/72' (30' lg.) - Hutchinson
	1016233-370	1/72' (30' lg.) - Mayrath
22	1016237-170	1/82' (15' lg.)

12" INLINE/MID-DRIVE

MAIN AUGER COMPONENTS

MISCELLANEOUS COMPONENTS

REF. NO.	PART NO.	DESCRIPTION
23	1011100	Connecting Band
24	1051D	Bronze Bushing f/Intake
25	1004287	Manual Container
--	1004744	Cap f/Operator's Manual Container
26	1014307	Access Hole Cover f/Drive Housing
27	1014654	Blow-off Cap, 12"
28	1007758	Chain f/Blow-off Cap
29	1013989	Hitch Pipe
30	1013526	Drain Hole Cover
Not Shown	1014615	Hitch Jack (See page P-6 for parts breakdown)

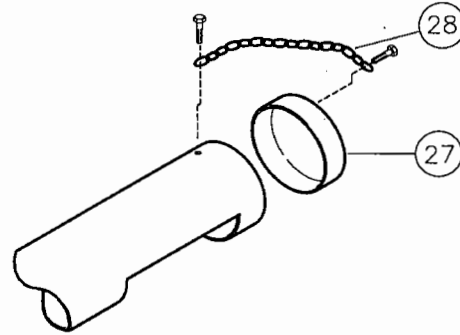

FLIGHT SECTIONS

REF. NO.	PART NO.	DESCRIPTION
34-38	---	Flight - Upper
34	1017657	f/32' (23'-10" lg.) 7 ga.
	1018642	f/32' (23'-10" lg.) 14" ga.
35	1016243	f/42' (8'-3" lg.) 7 ga.
	1016245	f/42' (8'-3" lg.) 1/4" ga.
36	1017972	f/62' (18'-0" lg.) 7 ga.
	1017973	f/62' (18'-0" lg.) 1/4" ga.
37	1015864	f/72' (28'-0" lg.) 7 ga.
	1016250	f/72' (28'-0" lg.) 1/4" ga.
38	1015973	f/82' (13'-0" lg.) 7 ga.
	1016253	f/82' (13'-0" lg.) 1/4" ga.
39-41	---	Flight - Center
39	1016242	f/42' 26'-3" lg.) 7 ga.
	1016244	f/42' (26'-3" lg.) 1/4" ga/
40	1015862	f/62' & 72' (6'-4" lg.) 7 ga.
40	1016248	f/62' & 72' (6'-4" lg.) 1/4" ga.
41	1015863	f/82' (11'-3" lg.) 7 ga.
41	1016251	f/82' (11'-3" lg.) 1/4" ga.
42-43	---	Flight - Middle
42	1015660	f/62', 72' & 82' (30'-0" lg.) 7 ga.
42	1016249	f/62', 72' & 82' (30'-0" lg.) 1/4" ga.
43	1014446	f/82' (20'-0" lg.) 7 ga.
43	1016252	f/82' (20'-0" lg.) 1/4" ga.
44	---	Flight - Lower
	1014019	f/All (5'-3" long)

MISCELLANEOUS FLIGHT COMPONENTS

REF. NO.	PART NO.	DESCRIPTION
50	1014122	Connecting Stub, Weld-in
51	1014121	Weld-in Tail Stub
52	1010485	Connecting Bolt 5/8" x 4" long (Grade 8)
53	1005111	Locknut, 5/8" side depress
--	53904	Repair Flight 3/8" thick

OPTIONAL INTERMEDIATE BEARING COMPONENTS

REF. NO.	PART NO.	DESCRIPTION
56	4011A91	Intermediate Bearing Hanger w/Bronze Bushing
--	1254D	Replacement Bronze Bushing Only
57	1012367	Mounting Plate for Bearing
58	1003016	3/4" x 1 1/2" Hex Head Capscrew f/Intermediate Brg. Hanger
--	1012298	Bearing Positioning Rod
59	1014277	Connecting Stub, Weld-in
60	1014646	Head Stub, Weld-in

FLIGHT SECTIONS FOR OPTIONAL INTERMEDIATE BEARINGS

REF. NO.	PART NO.	DESCRIPTION
45	---	Flight Upper (5'-6" long)
	1014643	f/7 ga. flighting
	1014644	f/1/4" flighting
46	---	Flight Intermediate (9'-9" long)
	1015648	f/7 ga. flighting
	1014642	f/1/4" flighting
47	---	Flight Center (8'-3" long)
	1014639	f/7 ga. flighting
	1014640	f/1/4" flighting
48	---	Flight Lower (5'-3" long) 7 ga.
	1014019	f/1/4" flighting

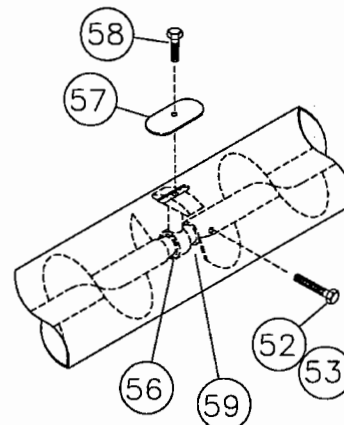

HITCH JACK

COMPLETE JACK NO. 1014615

REF. NO.	PART NO.	DESCRIPTION
1	1014607	Square Stand Tube
2	1014614	Support Tube Weldment
3	1014613	Band-on Mount
4	3359A11	T1000A Winch w/Handle
5	1015869	Cable, 3/16" x 8'
6	1014605	Base Plate
7	5931A1	12" Half Band, 4" wide
8	3223A1	Cable Pulley, 1" Bore
9	1015869	Spacer, 1" Dia. x 13/16" long
10	1004275	Washer head pin, 1/2" x 3 1/8" long
11	5321C	Cable Clamp, 3/16"
12	635164	Hair Pin Clip

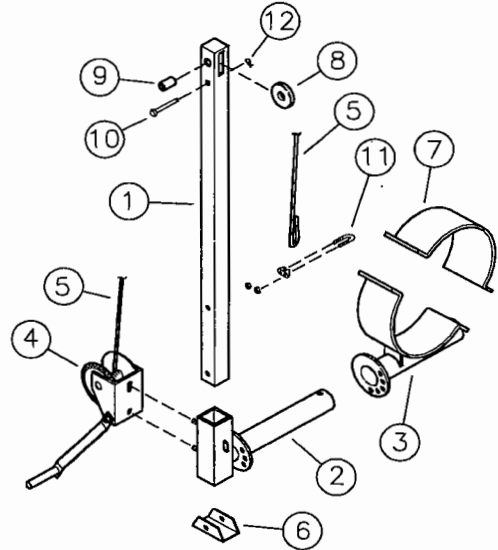

WINCH FOR JACK

COMPLETE WINCH NO. 3359A11

REF NO.	HUTCHINSON PART NO.	FULTON PART NO.	DESCRIPTION
A	40868	1514S01	Ratchet Pawl Kit
B	40839	4254S01	Pinion Shaft Kit
C	40360	6312	Handle*
--	41600	5621S01	Cable Keeper Kit

SPECIFICATIONS:
FULTON MODEL T1000A
CAPACITY: 1000 LB.
GEAR RATIO: 4.1 TO 1

*Handle nut (1/2" NC) not included.

NOTE: Repair parts for winch can also be purchased directly from:
 Fulton Mfg. Corp.
 P.O. Box 19903
 Milwaukee, WI 53219
 715-693-1700

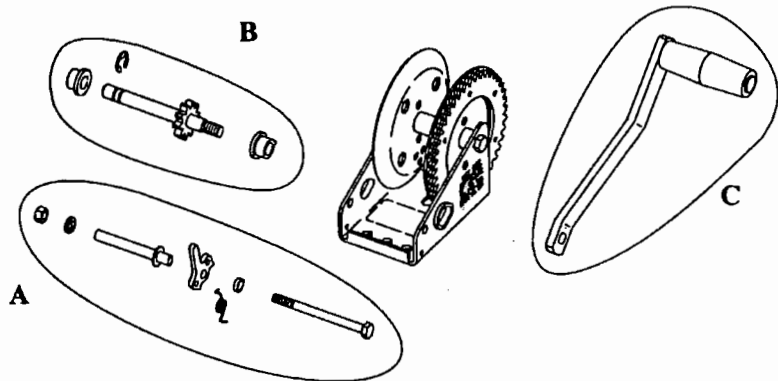

12" INLINE/MID-DRIVE

UNDERCARRIAGE COMPONENTS (FOR 32' & 42' MODELS)

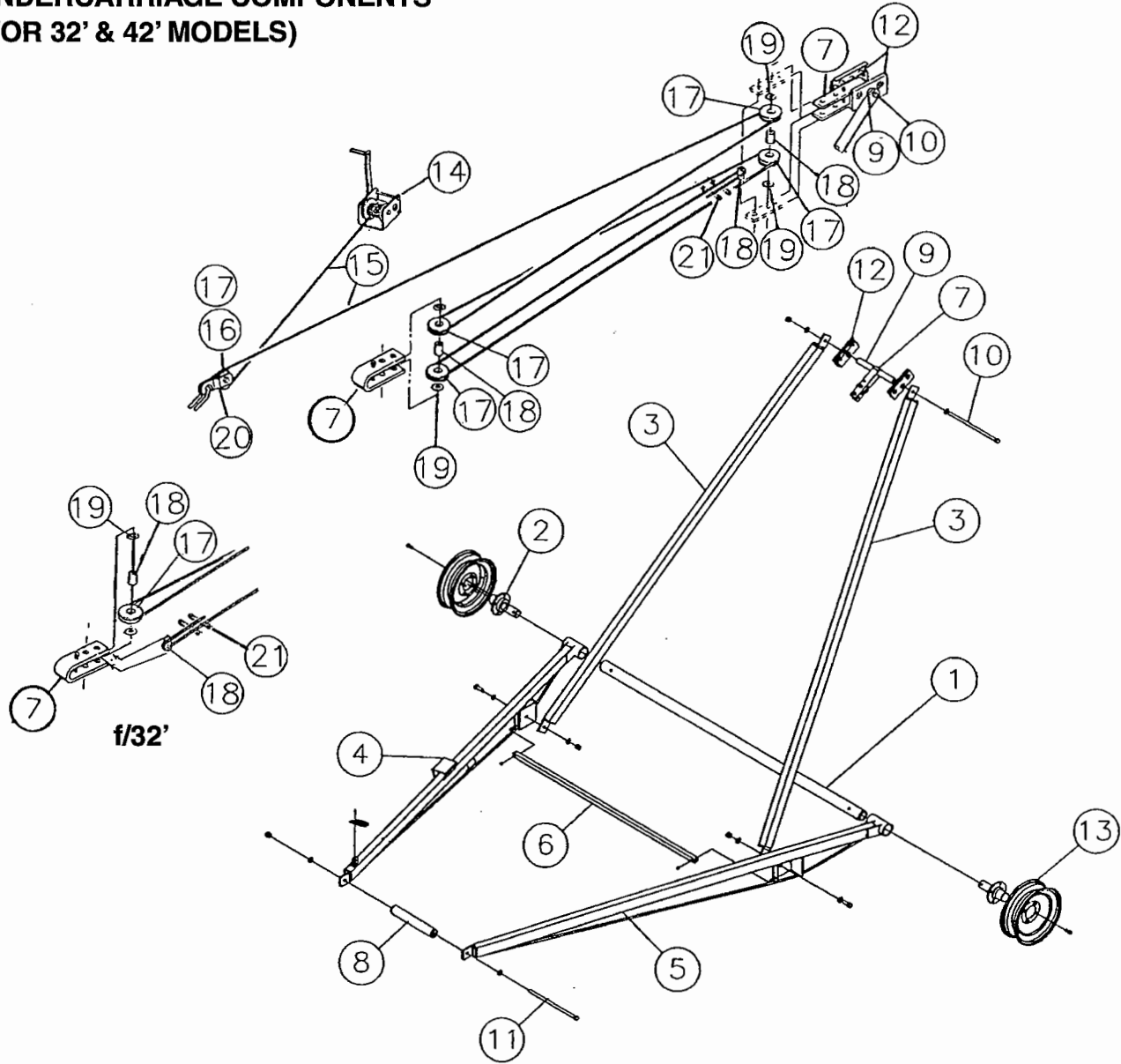

REF. NO.	PART NO.	DESCRIPTION	REF. NO.	PART NO.	DESCRIPTION
1	1018586	Axle Tube 2 7/8" O.D. x 94 1/2" lg.	10	1017675	3/4" x 16" Bolt
2	1001563	Spindle Assembly	11	1017676	3/4" x 17" Bolt
3	1016899	Lift Arm (32')	12	630036	Slide Roller Brkt.
	1017864	Lift Arm (42')	13	6393D	Wheel Rim
4	1016900	Left Hand Radius Arm (32')	14	3335A1	Winch Assembly K1550
	1017866	Left Hand Radius Arm (42')	15	1017774	Cable 1/4" x 39' f/32'
5	1016902	Right Hand Radius Arm (32')		1017957	Cable 1/4" x 62' f/42'
	1017867	Right Hand Radius Arm (42')	16	1007890	Clevis Plates
6	1017654	Cross Support (32')	17	1008195	3" O.D. Pulley
	1017882	Cross Support (42')	18	1007713	1 9/16" long Bushing
7	1007712	Pulley Clevis Strap	19	1007757	Washer 2 1/8" x 1 1/8" I.D. 10 ga.
8	1016955	Spacer Tube	20	50079A1	5/8" long Bushing
9	1016958	Trolley Spacer	21	6369C	1/4" Cable Clamp

SPINDLE & HUB ASSEMBLIES

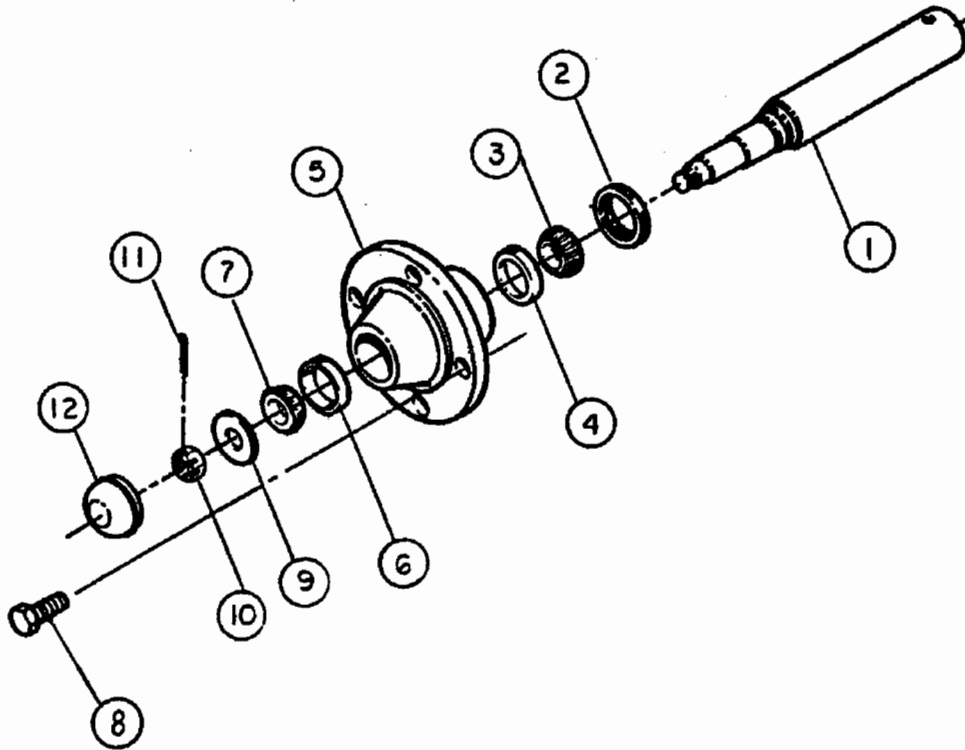

REF. NO.	DESCRIPTION	4-BOLT (2 1/16"O.D. x 10") f/32' & 42'	5-BOLT (2 3/8"O.D. x 14") f/62' & 72'	6-BOLT (2" O.D. x 10") f/82'
--	Spindle & Hub Assy.	1001563	1003104	1026688
1	Spindle	1001002	1001004	1026675
2	Grease Seal	106245	107233	1026088
3	Inner Cone (Timken No.)	3079R1 (LM67048)	3078R1 (LM48548)	1026089 (JL69349)
4	Inner Cup (Timken No.)	3148R1 (LM67010)	3147R1 (LM48110)	1026090 (JLM5068N)
5	Hub	**90174	*1003103	** 1025911
6	Outer Cup (Timken No.)	40552 (LM11910)	3148R1 (LM67010)	3148R1 (LM67010)
7	Outer Cone (Timken No.)	40551 (LM11949)	3079R1 (LM67048)	3079R1 (LM67048)
8	Lug Bolt	106241	--	106241
Not Shown	Lug Nut	--	107235	--
9	Washer	106252	107229	D1148
10	Slotted Hex Nut	106250 (5/8")	6360C (3/4")	D1147 (7/8")
11	Cotter Pin	D1146	107230	107230
12	Hub Cap	(5/32" x 1 1/4") 106244	(5/32" x 1 3/4") 107234	(5/32" x 1 3/4") 40588

*Furnished w/Cups and Lug Nuts.
 **Furnished w/Cups Only.

12" INLINE/MID-DRIVE

Page P-9

UNDERCARRIAGE COMPONENTS

(FOR 62', 72' & 82' MODELS)

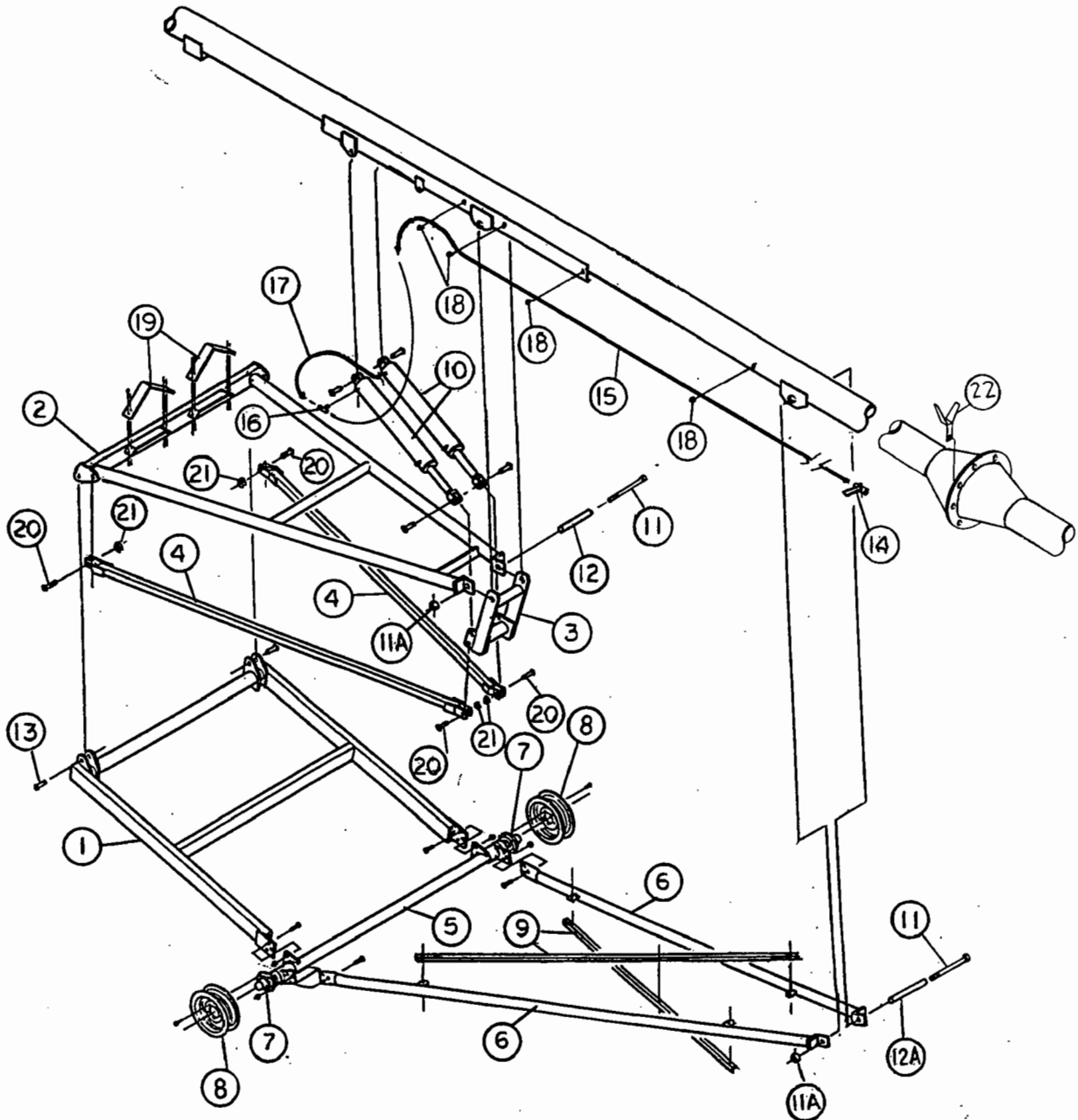

72' MODEL SHOWN

12" INLINE/MID-DRIVE

UNDERCARRIAGE COMPONENTS - FOR 62', 72' & 82' MODELS

REF. NO.	PART NO.	DESCRIPTION	REF. NO.	PART NO.	DESCRIPTION
1	---	Lower Frame	8	---	Wheel Rim
	1010595	f/62'		107225	5-Bolt Rim
	1010450	f/72'			f/62' & 72'
	1010783	f/82'		1025912	6-Bolt Rim
2	---	Upper Frame			f/82'
	1015629	f/62'	9	1011132	Crossbrace for 72' & 82' only (116 7/8" lg.)
	1014309	f/72'	10	1004369	Hydraulic Cylinder (4" Bore x 36" Stroke)
	1015630	f/82'			(See Page P-11 for parts breakdown)
3	---	H-Frame	11	1014107	1 1/4" Dia. x 18" long HHCS
	1015616	f/62'	11A	1014108	1 1/4" Nylon Locknut
	1014303	f/72' & 82'	12	1014002	Bushing (2" O.D. x 14" long)
4	---	H-Frame Tube	12A	1014003	Bushing (2" O.D. x 15" long)
	1010604	f/62'	13	1010475	Washer Head Pin 1" x 3 1/8" long
	1010482	f/72'	14	1005886	Hydraulic Ball Valve 1/2"
	1010805	f/82'	15	---	Hydraulic Hose, 3/8" dia.
5	---	Axle		1010606	f/62' - 34'-0" long
	1011099	f/62' & 72'		1007946	f/72' - 37'-6" long
	1011114	f/82'		1010833	f/82' - 43'-6" long
6	---	Lower Arm	16	---	Hydraulic Fitting
	1015638	f/62'		106413	90° Elbow (f/12" x 62' only)
	1014308	f/72'		1004732	Tee Fitting (f/12" x 72' & 82')
	1015639	f/82'	17	1010462	Hydraulic Hose
7	---	Spindle and Hub Assembly			f/12" x 72' & 82' (3/8" x 1'-6" long)
		(See Page P-8 for parts breakdowns.)	18	1006324	Hydraulic Hose Mounting Clamp
	1003104	5-Bolt Hub Assembly	19	1012417	Guide
		f/12" x 62' & 12" x 72'	20	1010605	1" x 2 1/2" long (Grade 5) Hex Head Capscrew
	1026688	6-Bolt Hub Assembly			f/62'
		f/12" x 82'	20	1012188	1" x 3" long (Grade 5) Hex Head Capscrew
					f/72' & 82'
			21	1007943	1" Nylon Locknut
			22	1007735	Hydraulic Hose Carrier

12" INLINE/MID-DRIVE

Page P-11

HYDRAULIC CYLINDER FOR 62', 72' & 82' UNITS

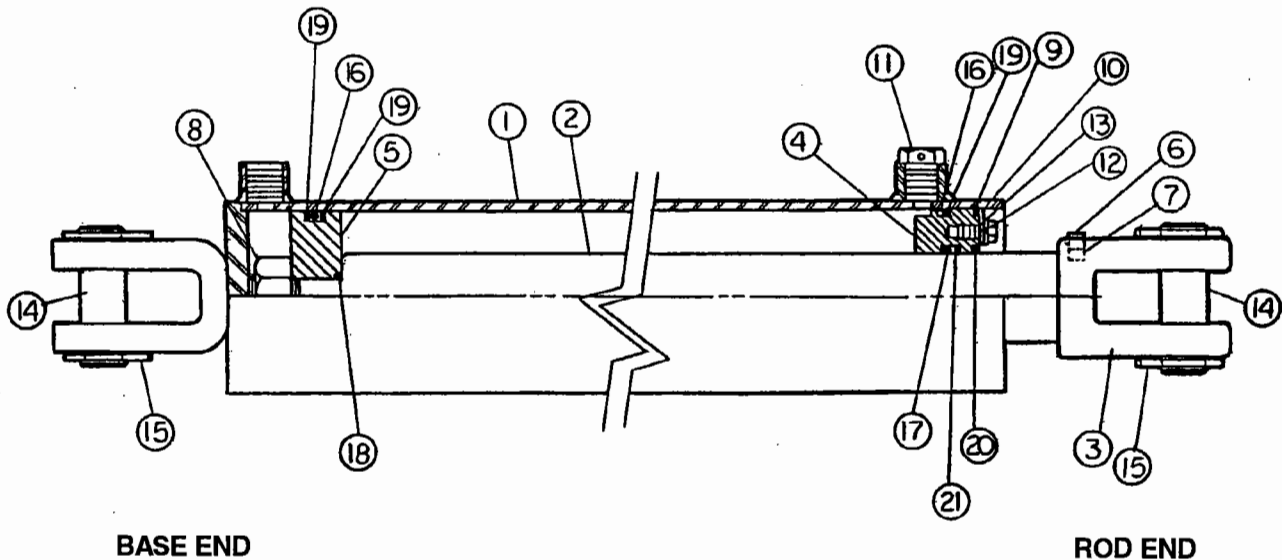

4" BORE x 36" STROKE
COMPLETE NO. 1004369

REF. NO.	DESCRIPTION	PART NO.
1	Cylinder Body	42889
2	Piston Rod	042013
3	Clevis	14980
4	Gland	42899
5	Piston	1004910
6	Setscrew 5/16" x 3/8" long	----
7	Nylon Plug	49049
8	Nut - Lock 1"	042021
9	Snap Ring	1004911
10	Retaining Plate	042004
11	Breather Plug (1/2" NPT)	042016
12	Bolt 5/16" - 3/4" long	4701-1
13	Lock Washer 5/16"	33144
14	Cylinder Pin 1" - 3-5/8"	1005212
15	Clip - Hairpin 3/16" x 1"	036719
16	*O-Ring Large	
17	*O-Ring Seal	
18	*O-Ring Small	
19	*Back-Up Washer	
20	*Piston Rod Wiper	
21	*Back-up Washer	

Seal Kit 042015

*** ONLY AVAILABLE AS PART OF A SEAL KIT.**

12" INLINE/MID-DRIVE

PTO DRIVE COMPONENTS

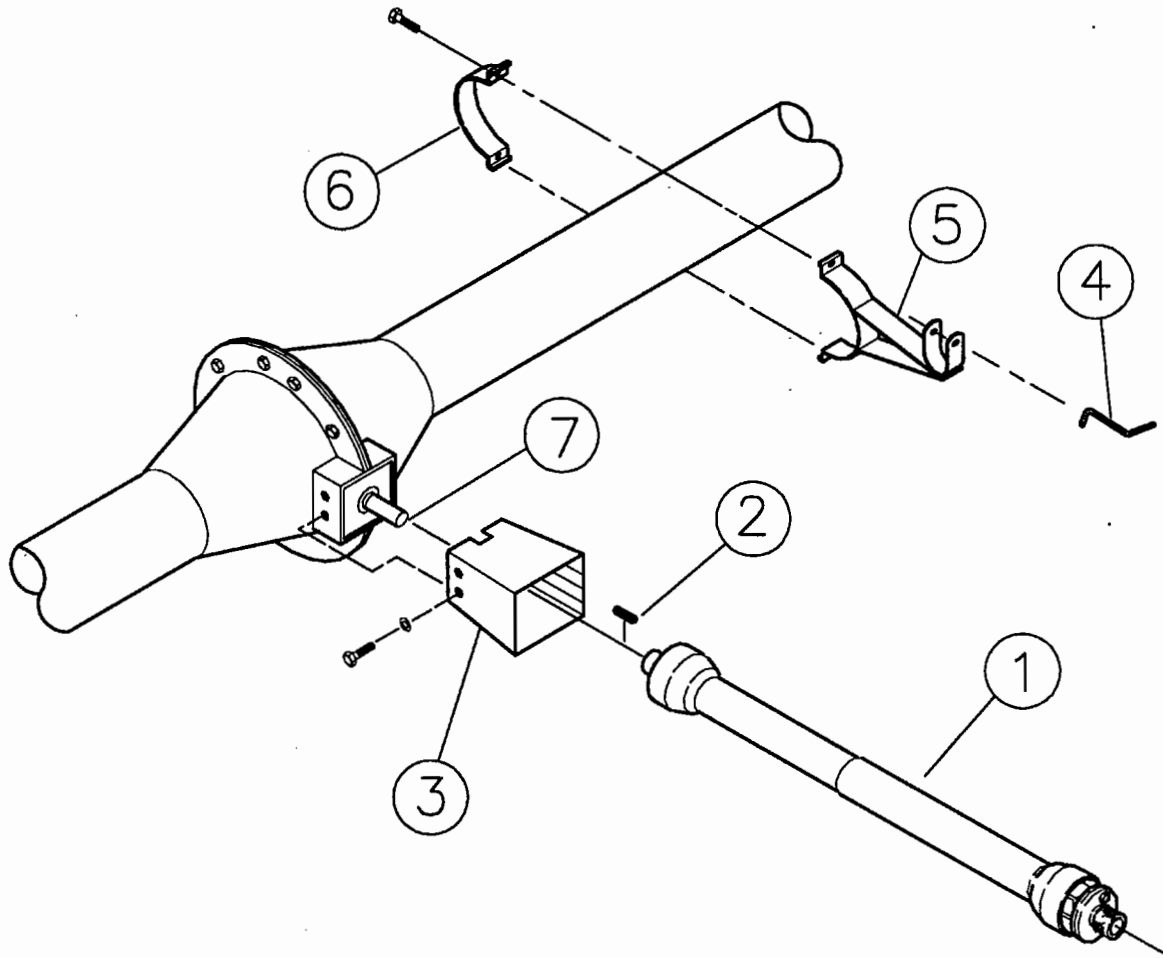

REF. NO.	PART NO.	DESCRIPTION
1	1027696	PTO Driveline (See parts breakdown on next page.)
2	4049A1	Key 3/8" x 1 1/2" long
3	1008107	PTO Driveline to Auger Shield
4	3338A1	Transport Keeper Pin
5	1014338	PTO Driveline Transport Bracket
6	5269A1	Halfband 2" wide
7	1009652	Gearbox (See gearbox information on page P-14.)

12" INLINE/MID-DRIVE

PTO DRIVELINE COMPONENTS

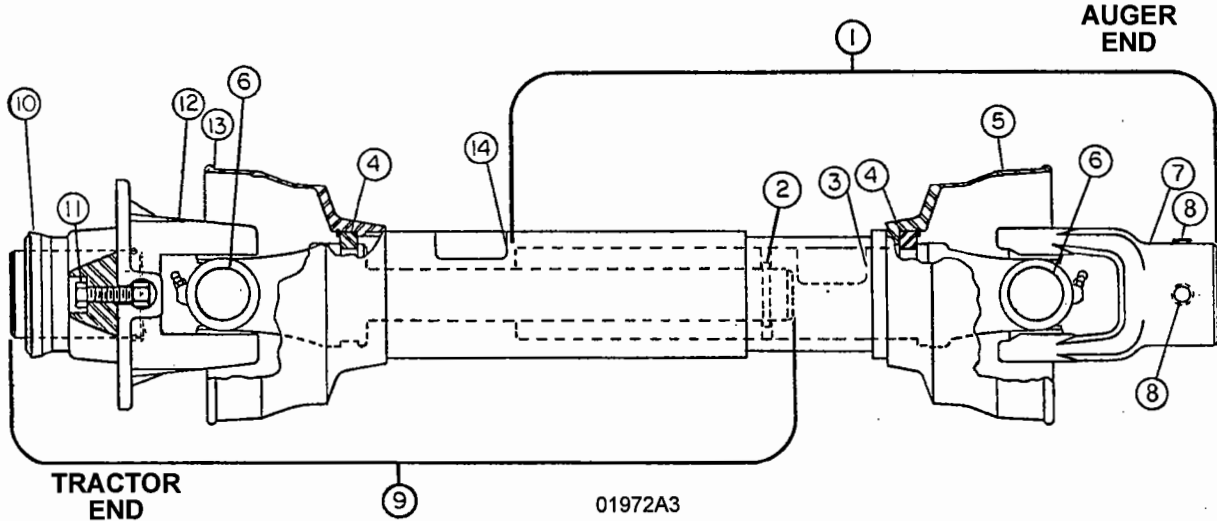

NOTE: Repair parts for PTO drivelines can also be purchased directly from:

**Weasler Engineering, Inc.
P.O. Box 558
West Bend, WI 53095**

**U-JOINT TYPE - 35R
AUGER END 1-1/2" BORE
WITH 3/8" KEYSEAT
TRACTOR END 1-3/8" - 6B SPLINE
WITH SHEAR BOLT**

REF. NO	DESCRIPTION	HUTCHINSON/ MAYRATH PART NO.	WEASLER PART NO.
--	PTO Driveline Complete	1027696	242-22829
1	Joint & Tube Half Assembly with Guard (Auger End)	1028781	92-22829
2	Roll Pin 1/4" x 1" long	1003691	11-10454
3	Inner Safety Sign	13-10022	13-10022
4	Shield Nylon Bearing Kit	1028784	19-15126
5	Inner Guard (Includes Ref. No. 4)	1028785	96-22829
6	U-Joint Cross Repair Kit	1028783	03-10045
7	End Yoke	1028787	35041-1572
8	.375 - 16 x .38 long Setscrew	33170	11-10215
9	Joint & Shaft Half Assembly with Guard (Tractor End)	1028782	93-22829
10	Spring Lock Flange Repair Kit	1028788	26-15120
11	Shear Bolt & Nut Kit (See Note)	1018892	--
12	Yoke & Ball Shear Assembly	1028789	40-30011
13	Outer Guard (Includes Ref. No. 4)	1028786	97-22829
14	Outer Safety Sign	13-10021	13-10021

Note: Shear Bolt Kit includes (6) 3/8" - 16 x 1" long Grade 8 hex bolts and locknuts.

12" INLINE/MID-DRIVE

GEARBOX (Complete Part No. 1027303)

1 1/2" DIA. INPUT SHAFT
2" DIA. OUTPUT SHAFTS

RATIO 1 TO 1

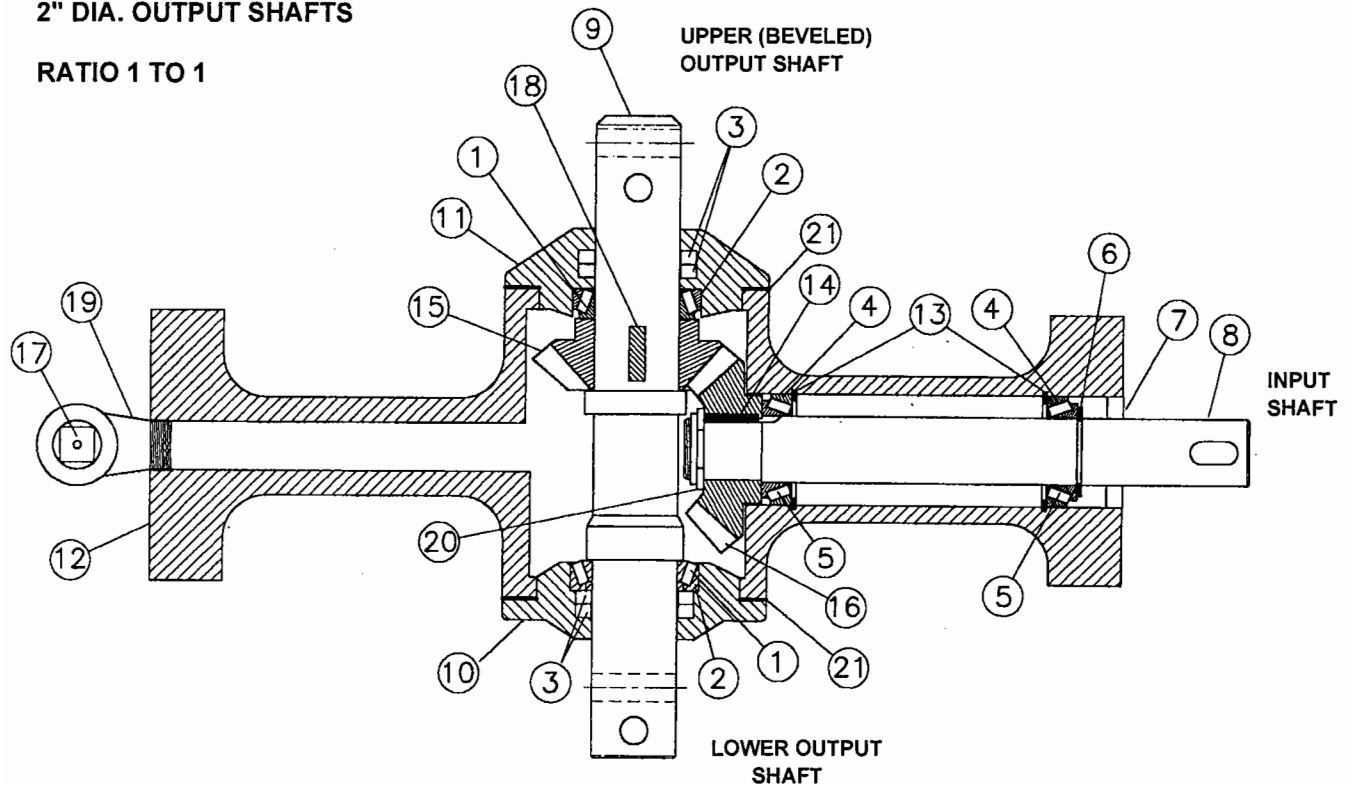

REF. NO	QTY.	PART NO.	DESCRIPTION
1	2	035434	2" Cone (3775)
2	2	035432	2" Cup (3720)
3	4	035854	Seal (2.75 O.D. x 2.00 I.D. x .312)
4	2	035440	1 1/2" Cup (LM29710)
5	2	035439	1 1/2" Cone (LM29749)
6	1	003541	Snap Ring (Waldes 5160-150)
7	1	035262	Seal (2.562 O.D. x 1.50 I.D. x .375)
8	1	1009653	Input Shaft - 1 1/2"
9	1	1009654	Output Shaft - 2"
10	1	020185	Bottom Cap
11	1	1027687**	Top Cap
12	1	1008023	Gearbox Housing
13	1	003543	Snap Ring (Waldes N5000-256)
14	1	020238	Key 5/16" x 5/16" x 1 1/8".
15	1	1027685**	Gear 17 Tooth - 2" Bore
16	1	020218	Gear 17 Tooth - 1 3/8" Bore
17	1	035930	Vent Plug - 3/4" NPT
18	1	003281	Key - Woodruff (3/8" x 1 1/4")
19	1	035931	Elbow - 3/4" NPT
20	1	837046	Stake Nut - 1 3/8"
21	4	020195	Gasket - .003
21	4	020196	Gasket - .005
21	4	020197	Gasket - .014
*	12	003100	3/8" x 1 1/4" HHCS w/Nylock
*	2	020009	Drain Plug - 1/4" NPT

*Indicates parts not shown.

**Kit No. 1027697 for Top Cap & Gear

12" INLINE/MID-DRIVE

Page P-15

ELECTRIC DRIVE COMPONENTS

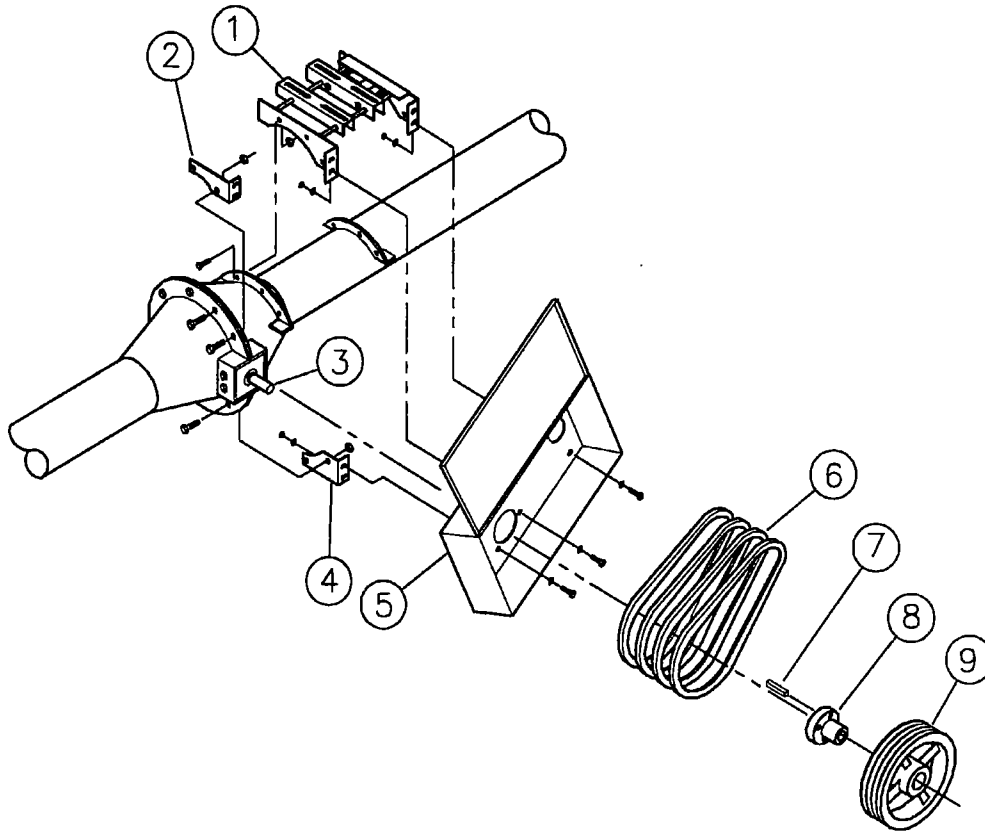

REF. NO.	PART NO.	DESCRIPTION
1	1014440	Motor Mount Frame
2	1014418	Belt Guard Mounting Bracket - Top
3	1009652	Gearbox (See previous page for parts breakdown)
4	1014552	Belt Guard Mounting Bracket - Bottom
5	1014393	Belt Guard
6	40132	B-97 Belt f/62', 72' & 82' Models
7	1038D	Square Key 3/8" x 2" long
8	3073A1	1 1/4" Bore SF QD Bushing f/4B Sheave
9	3251A1	18.4" Sheave 4B QD Bore f/62', 72' & 82' Models



Hutchinson/Mayrath

A Division of **GLOBAL** *Industries, Inc.*

P.O. Box 629 514 W. Crawford Clay Center, KS 67432
Phone 785-632-2161 1-800-523-6993 FAX 785-632-5964