

M50 PORTABLE MASS-TER MOVER

40', 50', 60', 65', 70'

80', 90' & 100' MODELS

OWNER'S & OPERATOR'S MANUAL

Effective January 10, 2016

Publication No. 1039962

Electric Drive Models

40' - M500404EB
50' - M500504EB
60' - M500604EB
65' - M500654EB
70' - M500704EB
80' - M500804EB
90' - M500904EB
100' - M501004EB

PTO Drive Models

40' - M500404PB
50' - M500504PB
60' - M500604PB
65' - M500654PB
70' - M500704PB
80' - M500804PB
90' - M500904PB
100' - M501004PB

IMPORTANT! The reducer gear box is shipped **Without Oil**.
Oil must be added before conveyor operation.
Refer to the Lubrication Section in this manual.

IMPORTANT! Although the winch gearboxes have been shipped
With Oil already installed, it is recommended to
check oil level before operation to ensure oil
level is correct.



Hutchinson/Mayrath

A Division of **GLOBAL** Industries Inc.

Hutchinson/Mayrath • P.O. Box 629 • Clay Center, KS. 67432
Ph. 785-632-2161 • Fx. 785-632-5964 • Toll Free 800-523-6993
www.hutchinson-mayrath.com



Hutchinson/Mayrath

A Division of **GLOBAL** Industries, Inc.

POLICIES AND PROCEDURES

- Prices:** Prices in effect at time of shipment will apply. Prices are subject to change without notice. All prices are F.O.B. Clay Center, Kansas. Orders shipped from locations other than Clay Center, Kansas will be subject to additional charges, such as back freight and/or additional freight.
- Service Charge:** A service charge will be assessed for all past due balances as permitted by state law not to exceed 1-1/2% per month.
- Minimum Order:** Processing and handling costs necessitate a minimum charge of \$15.00 net on all orders.
- Back Orders:** Back orders will be shipped as they become available. Contact Hutchinson/Mayrath Customer Service for alternative shipping options or if cancellation is desired.
- Damaged Goods:** It is the consignee's responsibility to check all shipments thoroughly upon receipt of goods. If any damage is discovered, it must be noted on the freight bill of lading before signing. The consignee must make necessary claims against the respective freight line. All damage claims must be submitted within 30 days of delivery receipt.
- Shortages:** All shortages must be noted at time of delivery. Shortages must be noted on the freight bill of lading before signing. Hutchinson/Mayrath must be advised of all concealed shortages upon discovery. Once notified of concealed shortages Hutchinson/Mayrath will advise corrective action to be taken.
- Return of Goods:** All returns must be approved by Hutchinson/Mayrath prior to shipment. All return requests will be issued a return authorization number. **NO RETURNS WILL BE ACCEPTED WITHOUT A RETURN AUTHORIZATION NUMBER AND PRIOR AUTHORIZATION FROM THE FACTORY.** All returns must be shipped prepaid. A 15% restocking charge will be applied to all returned merchandise. Custom Products may not be returned for credit. Only current products in new and salable condition may be returned. No safety devices may be returned for credit.
- Modifications:** It is the policy of Hutchinson/Mayrath to improve its product whenever possible and practical to do so. We reserve the right to make changes, improvements and modifications at any time without incurring the obligation to make such changes, improvements and modifications on any equipment sold previously.
- Limited Warranty:**
- (a) For a period of (1) year after receipt of goods by the original consumer buyer, Hutchinson/Mayrath will supply free of charge replacement parts for parts that prove defective in workmanship or material. Defective parts must be returned freight prepaid to a specified Hutchinson/Mayrath location. Only Hutchinson/Mayrath original repair parts may be used for warranty repairs.
 - (b) This limited warranty does not extend to parts designed to wear in normal operation and be replaced periodically; or to damage caused by negligence, accident, abuse or improper installation or operation.
 - (c) **GOODS NOT MANUFACTURED BY HUTCHINSON/MAYRATH CARRY ONLY THE MANUFACTURER'S WARRANTY.**
 - (d) **THIS UNDERTAKING IS IN LIEU OF ALL OTHER WARRANTIES, EXPRESSED OR IMPLIED, INCLUDING MERCHANTABILITY AND FITNESS FOR A PARTICULAR PURPOSE.**
- FAILURE TO FOLLOW THE INSTRUCTIONS CONTAINED IN THE OWNER'S & OPERATOR'S MANUALS AND THE ITEMS LISTED BELOW WILL RESULT IN THE VOIDING OF THIS LIMITED WARRANTY.**
- (1) Improper assembly, including failure to properly install all safety equipment.
 - (2) Improper installation.
 - (3) Unauthorized alternations of goods.
 - (4) Goods operated when obviously in need of repair.
 - (5) Use of unauthorized repair parts.
 - (6) Irresponsible operation.
 - (7) Used to handle materials other than free flowing, nonabrasive and dry materials, as intended.
 - (8) Damaged through abusive use or accident.
- Limitation of Liability:** BUYER AGREES THAT IN NO EVENT SHALL HUTCHINSON/MAYRATH HAVE LIABILITY FOR DIRECT DAMAGES THE EXCESS OF THE CONTRACT PRICE OF THE GOODS IN RESPECT OF WHICH CLAIM IS MADE. BUYER FURTHER AGREES THAT IN NO EVENT SHALL HUTCHINSON/MAYRATH ON ANY CLAIM OF ANY KIND HAVE LIABILITY FOR LOSS OF USE, LOSS OF PROFITS, OR FOR ANY INDIRECT, INCIDENTAL OR CONSEQUENTIAL DAMAGES.

TABLE OF CONTENTS

POLICIES AND PROCEDURES	(Inside Front Cover)
TABLE OF CONTENTS	1
SAFETY, General Safety Statement, Safety Alert Symbol, Safety Decals	2 - 4
GENERAL INFORMATION	5 - 9
Operator Qualifications, Sign-Off Sheet	5
Right and Left Designation	5
Intended Use Statement	5
Machine Inspection, Break-in Information	6
General Conveyor Information	6
Electric Drive Power Requirements	7
Tractor, PTO Requirements	7
Operating Capacities	7
Conveyor Dimensions, Conveyor Clearance	8-9
TRANSPORTING CONVEYOR	10 - 15
Transport Information, Transport Heights	10
Attach Conveyor to Towing Vehicle (Hitching Instructions), Conveyor Moving Hazard Area	11-12
Placement of Conveyor for Filling Grain Bin	12-14
Relocation of Conveyor	15
CONVEYOR OPERATION	16 - 18
Designated Work Area	16
Operating Procedures - Electric Models, Shutdown & Lockout	17
Operating Procedures - PTO Models, Shutdown & Lockout	18
Lubrication & Maintenance	19-27
Trouble Shooting	28
ASSEMBLY PROCEDURES	29 - 81
Trunk Housing Layout, Trunk Housing/Section Assembly	29-32
Track Assembly	33-39
Chain & Paddle Installation	40-41
Spout Installation	42
Truss Assembly, 70' Models	42
Truss Assembly, 80', 90' & 100' Models	43-48
Electric Drive Assembly, 40', 50', 60' & 70' Models	49-50
Electric Drive Assembly, 80', 90' & 100' Models	51-52
PTO Drive Assembly, 40', 50', 60', 65' & 70' Models	53-54
PTO Drive Assembly, 80', 90' & 100' Models	55-56
Inlet Hopper Assembly, Hitch & Hitch Jack and Drop Leg Jack Assembly	57-58
Undercarriage, 40', 50', 60' & 65' Models	59-61
Winch, Winch Cable, Cable Routing, Hand Winch f/ 40', 50', 60' & 65' Models	62-63
Undercarriage, 70' Models	64-67
Undercarriage, 80', 90' & 100' Models	68-71
Hydraulic Winch, Winch Mount, Cable Routing, 70', 80', 90' & 100' Models	72-73
Hydraulic Hose Installation, f/ Hydraulic Winch	74-75
Hydraulic Winch Mount and Cable Routing f/ 40', 50', 60' & 65' Models	76-77
Electric Winch Mount and Cable Routing f/ 40', 50', 60' & 65' Models	76-77
Electric Winch w/ Pendant Operation (2 HP, small winch)	78
Electric Winch Mount and Cable Routing f/ 70', 80', 90' & 100' Models	79-80
Electric Winch w/ Pendant Operation (5 HP, large winch)	81
PARTS LIST TABLE OF CONTENTS	82
PARTS LIST	P-1 - P-33

SAFETY

GENERAL SAFETY STATEMENT

This manual was written with the safety of the operator and others who work with the equipment as our prime concern. The instructions presented will help the reader learn **SAFE** day to day work practices. We want you as our partner in safety.

It is your responsibility as an owner, operator or supervisor to know what specific safety requirements and precautions exist and to make these known to all other personnel working with the equipment or in the area, so that they too may safely perform their duties and avoid any potentially hazardous situations.

We suggest the implementation of a Safety Program for all personnel that includes, but is not limited to, the proper use of PPE (personal protective equipment), Fall Protection Systems and Lock Out-Tag Out procedures.

Please remember safety equipment provides important protection for persons around a grain handling system that is in operation. Be sure **ALL** safety shields and protection devices are installed and properly maintained. If any shields or guards are damaged or missing, contact your dealer to obtain the correct items.

Avoid any alterations of the equipment. Such alterations may create a dangerous situation where serious injury or death may occur.

SAFETY ALERT SYMBOL

The safety symbol shown is used throughout this manual to alert you to information about unsafe actions or situations, and will be followed by the word DANGER, WARNING, or CAUTION.

DANGER - Indicates immediate hazards that may result in severe injury or death. **WARNING** - Indicates unsafe actions or situations that may cause severe injury, death and/or major equipment or property damage. **CAUTION** - Indicates unsafe actions or situations that may cause injury, and/or minor property damage.

Watch this symbol - it points out important safety precautions. It means - **ATTENTION! Become alert! Your safety and the safety of others is involved!** Read the message that follows the symbol when a warning is given, be alert to the possibility of personal injury or death.



Follow Safety Instructions

Carefully read all safety messages in this manual and safety signs on your machine. Check to ensure all Safety Decals are present and in good condition.

If a decal cannot easily be read for any reason, or has been painted over, replace the decal immediately. Safety decals are offered free of charge, and can be ordered through your Hutchinson/Mayrath dealer or directly from the factory.

Learn how to operate the machine and how to use controls properly.

Keep your machinery in proper working condition. Understand service procedures before doing work. Never lubricate, service or adjust machine while it is in operation.

Keep work area clean, dry and free from of all debris and tools which may cause accidental tripping or falling.



Read and Understand Manual

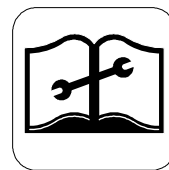

Understand Service Procedures



Keep Work Area Clean

Prepare for Emergencies

Keep emergency numbers for doctors, ambulance service, hospital and fire department near your telephone.

Keep a first-aid kit and fire extinguisher handy.

Be prepared if a fire starts



First Aid Equipment



Fire Extinguisher

Wear Proper PPE (Personal Protective Equipment)

Some materials can create flying debris when they are filed, cut or drilled. Safety glasses should be worn at all times to protect your eyes from such debris.

Hearing protection should be worn when operating power tools or other power equipment that could be harmful to your hearing.

Gloves should be worn to protect your hands from sharp metal and plastic edges, as well as providing protection from the handling of heavy objects.

Wear steel toe boots to protect your feet from falling debris.

Wear a hard hat to help protect your head from falling objects as well as from accidental bumping.

Use caution when working at elevations greater than four (4) feet (1.22 m) above the ground.

Use the appropriate fall protection equipment as set forth by OSHA guidelines and regulations.

A respirator may be needed to prevent breathing potentially toxic fumes and dust, especially when working within a grain bin or storage structure.

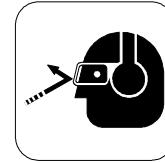

Eye & Hearing Protection



Gloves



Steel Toe Boots

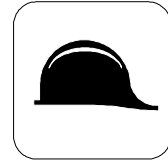

Hard Hat



Fall Protection

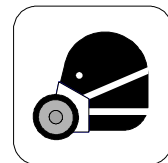

Respirator

Operate Electric Motor(s) Properly

Do not operate electric motor equipped units until motor(s) are properly grounded.

Know how to "Shutdown and Lockout" the power source. Shutdown and lockout power source before performing any service, maintenance or adjustments to the unit.

Disconnect power on electrical driven units before resetting motor overloads.

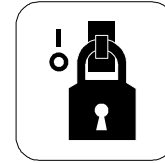

Lockout / Tagout



Electric Shock Hazard

Stay Clear of Moving Parts

Keep all shields, covers and safety devices in place at all times.

Entanglement in moving chains, rotating impeller arms and sprockets will cause serious injury or death.

Wear close fitted clothing. Keep hands, feet and clothing away from moving parts.

Shutdown and lockout power source before making adjustments, cleaning or maintaining the equipment.

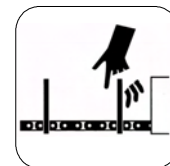

Entanglement Hazards

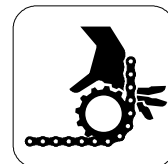

SAFETY

GRAIN BIN SAFETY

The M50 Portable Mass-Ter Mover is generally designed to transfer grain into grain bins or other storage structures. **Be aware of the dangers inherent in grain bins.**

Consult the grain bin manufacturer's manual for information on the proper loading and unloading of the bins, structural stress analysis, adequate venting and important safety information.



WARNING! Do Not enter the bin if the grain has “Bridged” or has not flowed normally out of the bin, See Example’s 1 & 2. The grain may suddenly break loose and bury resulting in suffocation.



Do Not enter the bin unless all power driven equipment has been shut down and locked out. Never enter the bin unless monitored by another person.

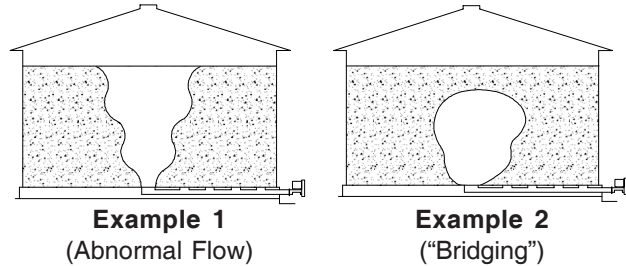

SAFETY DECALS

Check to ensure all Safety Decals are present and in good condition. If a decal cannot easily be read for any reason, or has been painted over, replace the decal immediately. Safety decals are offered free of charge, and can be ordered through your Hutchinson/Mayrath dealer or directly from the factory.

Refer to the Parts List Section for decal Part No’s. and location of decals on components.

⚠ DANGER

**BEWARE OF POWER LINES
ELECTROCUTION HAZARD**

- THIS MACHINE IS NOT INSULATED.
- KEEP AT LEAST 10 FEET AWAY FROM OVERHEAD ELECTRICAL WIRES.
- ELECTROCUTION CAN OCCUR WITHOUT DIRECT CONTACT.

FAILURE TO HEED WILL RESULT IN SERIOUS INJURY OR DEATH!

⚠ WARNING

- THE TRANSPORT WIDTH EXCEEDS 8' 6".
- WHEN TOWING OVER PUBLIC ROADS COMPENSATE FOR THE ADDITIONAL WIDTH.
- WATCH FOR OTHER TRAFFIC AND OBSTRUCTIONS ALONG THE ROADWAY.

FAILURE TO HEED WILL RESULT IN SERIOUS INJURY OR DEATH!

⚠ DANGER



DO NOT ATTEMPT TO ASSEMBLY BEFORE SUPPORTING THE AUGER WITH AN OVERHEADED HOIST OR OTHER SAFE, SUITABLE MEANS. THE AUGER MAY COLLAPSE WHILE LOOSE ENDS & COMPONENTS IF NOT SUPPORTED.

FAILURE TO HEED WILL RESULT IN SERIOUS INJURY OR DEATH!

⚠ DANGER



UPENDING HAZARD

- SUPPORT DISCHARGE END OR ANCHOR INTAKE END TO PREVENT UPENDING.
- DO NOT PUSH THE UNDERCARRIAGE BY HAND.
- EMPTY MACHINE BEFORE MOVING.
- LIFT THE INTAKE END SLOWLY AND REVER- SIBLY. HITCH OR WHEEL CONTROL BAR, MANUAL CONTROL, UNTIL SECURELY ATTACHED TO TOW BAR OR RESTING ON THE GROUND.
- LOWEN TO TRANSPORT POSITION IMMEDIATELY WHEN CLEAR FROM GRAIN STORAGE STRUCTURE.

FAILURE TO HEED WILL RESULT IN SERIOUS INJURY OR DEATH!

⚠ CAUTION

- READ AND UNDERSTAND THE OPERATOR'S MANUAL BEFORE OPERATING.
- DO NOT REMOVE OR MODIFY ANY GUARDS.
- MAKE CERTAIN EVERYONE IS CLEAR BEFORE OPERATING OR MOVING THE MACHINE.
- KEEP HANDS, FEET, HAIR AND CLOTHING AWAY FROM MOVING PARTS.
- STOP MACHINE AND LOCKOUT POWER TO ADJUST, SERVICE OR CLEAN.
- DISCONNECT POWER BEFORE SETTING MOTOR OVERLOAD.
- MAKE CERTAIN ELECTRIC MOTORS ARE GROUNDED.
- KEEP CHILDREN WELL CLEAR OF WORK AREA.

⚠ WARNING



- ESCAPING HYDRAULIC OIL UNDER PRESSURE WILL CAUSE SERIOUS INJURY IF IT PENETRATES THE SKIN. SEE A DOCTOR IMMEDIATELY IF INJURED.
- USE BIVALVE OR WOOD AS A BACKSTOP WHEN SEARCHING FOR HYDRAULIC LEAKS.
- RELIEVE HYDRAULIC PRESSURE BEFORE DISCONNECTING HYDRAULIC LINES.
- PERFORM INSPECTION AND MAINTENANCE OF THIS HYDRAULIC SYSTEM REQUIRED. SEE OWNER'S/ OPERATOR'S MANUAL.

FAILURE TO HEED WILL RESULT IN SERIOUS INJURY OR DEATH!

⚠ DANGER



MOVING CHAIN & PADDLES

- KEEP HANDS, FEET, HAIR AND CLOTHING AWAY FROM INTAKE.
- DO NOT REMOVE OR MODIFY ANY GUARDS.
- KEEP CHILDREN WELL CLEAR OF WORK AREA.

FAILURE TO HEED WILL RESULT IN SERIOUS INJURY OR DEATH!

⚠ DANGER

STOP

IF ANY GUARDS (SHIELDS OR SAFETY DEVICES) ARE DAMAGED OR MISSING, ORDER PARTS IMMEDIATELY BY CALLING:

1-800-553-0903
OR WRITE TO:
HUTCHINSON/MAYRATH
P.O. BOX 629
CLAY CENTER, KS 67432

⚠ DANGER



DO NOT OPERATE WITH COVER OPEN!

- STOP MACHINE AND LOCKOUT POWER TO ADJUST, SERVICE OR CLEAN.
- KEEP HANDS, FEET HAIR AND CLOTHING AWAY FROM MOVING CHAIN AND PADDLES.

FAILURE TO HEED WILL RESULT IN SERIOUS INJURY OR DEATH!

OPERATOR QUALIFICATIONS



WARNING!

Anyone who will operate or work around this machine shall first read this manual! This manual must be delivered with the equipment to its owner. Failure to read this manual and its safety instructions is a misuse of the equipment.

Operation of this conveyor system shall be limited to competent and experienced persons. In addition, anyone who will operate or work around a conveyor must use good common sense. In order to be qualified, he must also know and meet all other requirements, such as:

1. Some regulations specify that no one under the age of 16 may operate power machinery. This includes this conveyor. It is your responsibility to know what these regulations are in your area or situation.
2. Current OSHA regulations state in part: "At the time of initial assignment and at least annually thereafter, the employer shall instruct every employee in safe operation and servicing of all equipment with which the employee is, or will be involved." *
3. Unqualified persons are to stay out of the work area. See Page 16.
4. A person who has not read and understood all operating and safety instructions is not qualified to operate the machine.

5. Persons operating, servicing or repairing equipment that requires above ground work shall be properly secured with the use of "fall protection" equipment as set forth by OSHA guidelines and regulations.

*Federal Occupational Safety & Health Standards for Agriculture Subpart D, Section 1928.57 (a)(6).

INTENDED USE STATEMENT

This product is intended to provide the mechanical means to move grains or commodities of similar physical size and properties from an inlet point, or points, on the conveyor to a discharge point. Chain speed of the conveyor should not be altered from factory settings.

Allowable capacities have been outlined in this manual, and the flow of the material being conveyed must be regulated into the inlet (or inlets) so as not to exceed the capacity of the unit.

Any use other than what is specified in the above is not recommended by the manufacturer.

SIGN OFF SHEET

As a requirement of OSHA, it is necessary for the employer to train the employee in the safe operation and safety procedures with this conveyor. We include this sign off sheet for your convenience and personal record keeping.

<u>Training Sign-Off Sheet</u>		
Date	Employer Signature	Employee Signature

RIGHT and LEFT DESIGNATION

When referencing the left, right, front or rear of the conveyor, it is always determined by standing at the inlet end of the conveyor and looking towards the discharge end.

MACHINE INSPECTION

Our conveyors are well made and we are proud of our line of equipment. We would like you, as our customer, to do your part in using caution and good judgement in using our equipment, as well as any other machinery.

After delivery of your new conveyor and/or completion of assembly and before each use, inspection of the machine is mandatory. The conveyor should be frequently checked and serviced to operate freely. Use the assembly instructions in this manual as a reference to determine that the conveyor is assembled properly. This inspection should include, but not be limited to:

1. Check to see that all shields listed in the assembly instructions are in place, secured and functional.
2. Check all safety signs (decals) and replace any that are worn, missing or illegible. Safety signs may be obtained free of charge from your dealer or ordered from the factory.
3. Check **all** fasteners; nuts, bolts, set screws etc. for tightness.
4. Check winch and cable for security and operation. Winch should have at least three complete wraps of cable around the winch drum with conveyor in the full down position.
5. Check oil levels in gearboxes (See the Lubrication and Maintenance Section in this manual).
6. Make sure clean-out door in bottom of hopper and all inspection opening covers are shut and secured.
7. Are drive belts and conveyor chains properly adjusted (See Maintenance Section).

GENERAL CONVEYOR INFORMATION

WARNING! Use caution when working in areas above the ground. Persons operating, servicing or repairing equipment that requires above ground work shall be properly secured with the use of "fall protection" equipment as set forth by OSHA guidelines and regulations.



Metal buildings, scaffolding and other types of work surfaces can become slippery, especially when surfaces are wet and/or oily. This can create hazardous working conditions. Use caution when working, climbing or walking on these surfaces.

*General Information (con't.)*

WARNING! During initial start-up and break-in period, the operator shall be aware of any unusual vibrations or noises that would indicate a need for service or repair.



Keep all safety shields and devices in place. Keep hands, feet, and clothing away from moving parts.



The operator shall have a full view of the conveyor work area and check that all personnel are free from designated work areas before adding power.

- Obtain any needed replacement parts from your dealer and install **before** using the machine.
- Inspect the drive before adding power and know how to **shutdown** in an emergency (See Pages 17 & 18).
- During operation of your conveyor, one person shall be in a position to monitor the operation.
- Visually inspect the conveyor periodically during operation, be aware of all adjustments and checks which should be performed.
- The conveyor may be operated at speeds from 450 to 540 RPM's (conveyor speed in excess of recommended speed causes excessive wear).
- **Do Not** attempt full load operation at speeds below 450 RPM, as high torque requirements may damage the conveyor.
- It is important to become familiar with the routine operating procedures before attempting start-up.

BREAK-IN INFORMATION

Any conveyor when it is new, or after sitting idle for a season should go through a "break-in" period. The conveyor should be run at partial capacity until several hundred bushels of grain have been conveyed to polish the housing. A conveyor that has not been polished in this manner requires greater horsepower to operate, and damage to conveyor can occur.

When the housing has been polished and smooth, the conveyor can be run at full capacity. Never run the conveyor empty for any length of time as excessive wear will result. If at all possible, do not stop or start the conveyor under load, especially before the housing becomes well polished, as this may cause the conveyor to "freeze-up."

ELECTRIC DRIVE POWER REQUIREMENTS

The conveyor can also be operated using an electric drive motor. Always use a motor with the required power recommended in the chart below. Use a 60 hz motor that operates at 1750 RPM (50 hz @ 1460 RPM).

Electric motors and controls shall be installed by a qualified electrician and must meet the standards set by the National Electric Code and all local and state codes.

A magnetic starter should be used to protect your motor when starting or stopping. It should stop the motor in case of power interruption, conductor fault, low voltage, circuit interruption and/or motor overload. The motor should then be restarted manually.

A main power disconnect switch that can be locked only in the “Off” position shall be provided. This shall be locked whenever work is being done to the conveyor.



WARNING! Shut off power and lockout whenever cleaning or servicing the conveyor.

The reset and starting controls must be located so that the operator has full view of the entire operation.



Disconnect power before resetting motor overloads. Make certain electric motor is grounded.

Do Not enter the grain bin unless all power driven equipment has been shutdown and locked out.



A main power disconnect switch that can be locked in only the “Off” position shall be used. This shall be locked whenever work is being done to the conveyor.

Conveyor Length	Recommended Horsepower	Recommended Motor Sheave*
40' (12.2 m)	15 hp (11 kW)	4.2" P.D. 5B
50' (15.5 m)	15 hp (11 kW)	4.2" P.D. 5B
60' (18.3 m)	20 hp (15 kW)	4.2" P.D. 5B
65' (19.8 m)	20 hp (15 kW)	4.2" O.D. 5B
70' (21.3 m)	20 hp (15 kW)	4.2" O.D. 5B
80' (24.4 m)	25 hp (18.5 kW)	4.2" P.D. 5B
90' (27.4 m)	25 hp (18.5 kW)	4.2" P.D. 5B
100' (30.5 m)	25 hp (18.5 kW)	4.2" P.D. 5B

* Motor Sheave is provided.
P.D. = Pitch Diameter

TRACTOR & PTO REQUIREMENTS

The conveyor PTO was designed for use with a tractor that is capable of operating at 540 RPM's (speeds greater than this will cause excessive wear and/or damage to the conveyor).

NOTE: The PTO driveline furnished with the conveyor is equipped with a “Spring-Lok” coupler at the tractor end. This type of coupler is spring loaded and will fit the standard 1 3/8” x 6 splined PTO shaft from a tractor.

The PTO driveline is also equipped with a shear bolt at the tractor connection. The shear bolt protects the conveyor from damage should the conveyor become plugged or subjected to high loads. If this scenario should occur, the shear bolt would “shear off” causing the connection to the conveyor to suddenly stop (the tractor PTO would still continue turning, but not the conveyor driveline). **Immediately shutdown the tractor and lockout before attempting to investigate the cause of the problem.**

Extra shear bolts are located in the operator’s manual container. Always use same size and strength shear bolts (3/8-16 x 1” Grade 8 PLT).

The tractor should be equipped with an adjustable drawbar and have a hydraulic control circuit capable of producing **2000 PSI (13790 kPa)** for the hydraulic winch used for raising and lowering the main conveyor (the hydraulic winch is standard on the 70 ft. thru 100 ft. models).

OPERATING CAPACITIES

The M50 Portable Mass-Ter Mover conveyor has the ability to convey 5,000 BPH (135 TPH) of reasonably dry grain during normal operating conditions.

Maximum possible capacity will be less with high moisture grain (above 15%) than with dry grain. Twenty-five percent (25%) moisture could cut capacity back by as much as 40% under some conditions.

The results or capacities of conveyors can vary greatly under varying conditions. Different materials, moisture content, amounts of foreign matter, angle of operation, methods of feeding and conveyor speed all play a role in the performance of the conveyor. A conveyor operating at a 40° incline could be cut by 20% in capacity compared to a conveyor operating horizontally.

Overfeeding the conveyor would result in increased power requirements, extra strain on the driveline and possibly a complete stalling out. Under the “extra” grain pressure conditions, a control gate or other method of limiting the amount of grain being fed into the conveyor should be used.

CONVEYOR DIMENSIONS

CONVEYOR CLEARANCE



WARNING! Be alert of all overhead obstructions and electrical wires, failure to do so can result in electrocution, serious injury to operator and bystanders, conveyor damage and/or extensive property damage.

Lower the conveyor well below the level of power lines before moving. Maintain at least 10 feet of clearance (electrocution can occur without direct contact of the power lines).

The clearance dimensions for the conveyors are shown below and on the following page.

The dimensions below are given for the conveyor when it is in its full raised position (See Page 10 for information on the transport height for the conveyor).

Never transport the conveyor while it is in the raised position, even when moving from one work site to another. Always transport the conveyor in its full down position.

Model 50 Portable Conveyor Dimensions (40° maximum height)

	A	B	C		A	B	C
40'	24'-10 5/16" (7.58 m)	14'-3 11/16" (4.36 m)	14'-6 27/32" (4.44 m)	70'	43'-7 11/32" (13.29 m)	22'-6 19/32" (6.87 m)	27'-1 13/32" (8.27 m)
50'	31'-3 1/16" (9.53 m)	17'-5 1/4" (5.31 m)	18'-6" (5.74 m)	80'	50'-6 1/2" (15.41 m)	26'-1 1/16" (7.95 m)	31'-1 3/4" (9.49 m)
60'	37'-8 7/32" (11.41 m)	20'-6 3/32" (6.25 m)	22'-5 11/16" (6.85 m)	90'	56'-11 3/8" (17.36 m)	30'-2" (9.19 m)	33'-11" (10.34 m)
65'	40'-4 21/32" (12.31 m)	23'-3 3/32" (7.09 m)	22'-5 3/8" (6.84 m)	100'	63'-4 3/4" (19.32 m)	31'-1 7/32" (9.48 m)	40'-6" (12.34 m)

- A – Discharge height at 40°
- B – Free clearance above wheels
- C – Closest point to bin at 40° (eave level)

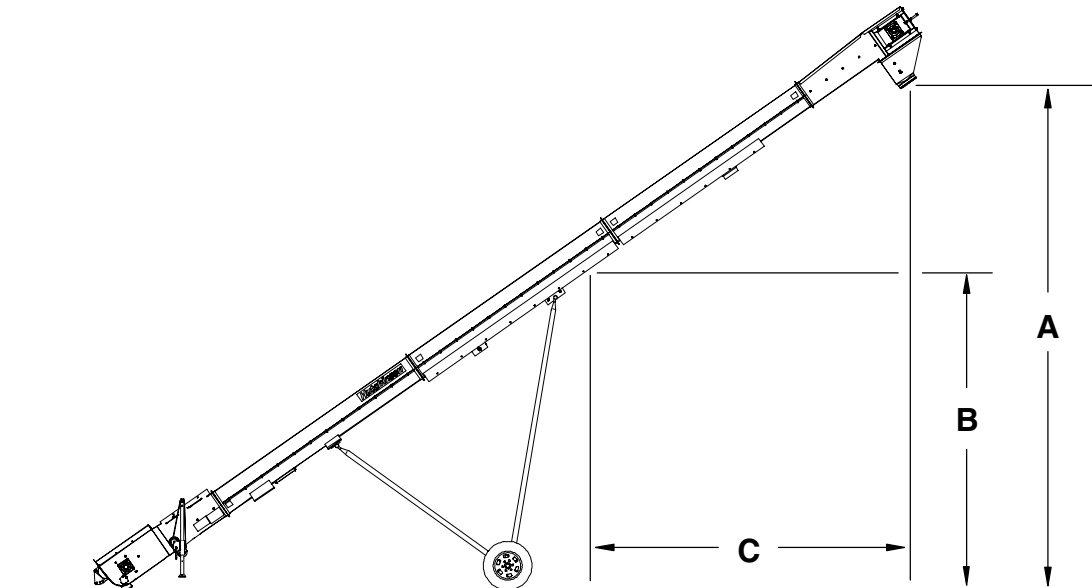

CONVEYOR DIMENSIONS

CONVEYOR CLEARANCE (con't.)

The clearance dimensions for the conveyor shown below are given for when the conveyor is set up for operation at the work site.

Though the dimensions are as close to accurate as possible, the dimensions may vary depending on bin size, type of storage structure, conveyor position, and other factors associated with your particular application.

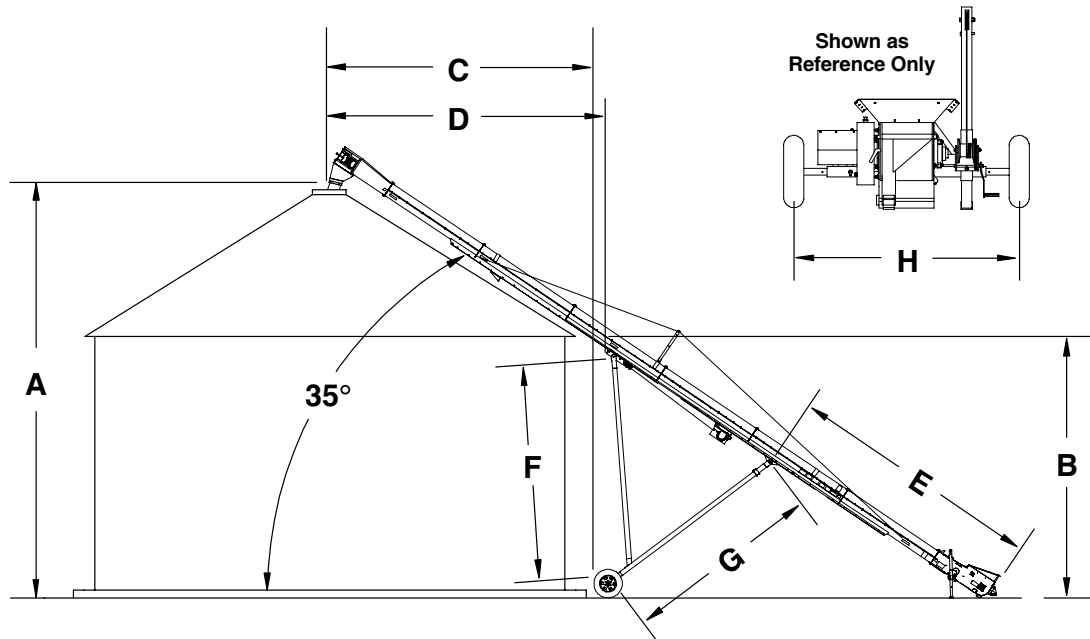

Model 50 Portable Conveyor Dimensions (35°)

	A	B	C	D	E	F	G	H
40'	21'-11 19/32" (6.70 m)	12'-7 7/8" (3.86 m)	15'-6 7/8" (4.75 m)	14'-5 1/2" (4.41 m)	10'-11 3/8" (3.34 m)	12'-5 3/16" (3.79 m)	9'-6 17/32" (2.91 m)	7'-10 1/2" (2.40 m)
50'	27'-23/32" (8.25 m)	15'-5 1/2" (4.71 m)	18'-10 5/32" (5.74 m)	16'-6" (5.03 m)	13'-4" (4.06 m)	16'-0" (4.88 m)	11'-10 1/2" (3.62 m)	8'-8 9/16" (2.66 m)
60'	33'-5 1/4" (10.19 m)	18'-3 23/32" (5.58 m)	23'-10 9/16" (7.28 m)	23'-5 5/8" (7.15 m)	16'-7 3/8" (5.06 m)	16'-11" (5.16 m)	14'-1" (4.29 m)	8'-5 1/4" (2.57 m)
65'	35'-10" (10.92 m)	20'-4 1/16" (6.20 m)	24'-4 1/4" (7.42 m)	22'-8 7/8" (6.93 m)	16'-6 21/32" (6.65 m)	19'-11" (6.07 m)	16'-11 27/32" (5.18 m)	9'-3 1/2" (2.83 m)
70'	38'-8 1/16" (11.79 m)	20'-1/2" (6.11 m)	28'-10 21/32" (8.81 m)	26'-8 1/8" (8.13 m)	18'-5" (5.61 m)	20'-2 1/4" (6.15 m)	15'-10 25/32" (4.85 m)	11'-6 3/4" (3.52 m)
80'	44'-10 29/32" (13.69 m)	23'-2 29/32" (7.08 m)	33'-2 21/32" (10.13 m)	32'-5 19/32" (9.90 m)	20'-6 21/32" (6.27 m)	22'-2 19/32" (6.77 m)	18'-7 5/16" (5.67 m)	12'-5 3/8" (3.79 m)
90'	50'-7 23/32" (15.44 m)	26'-8 3/32" (8.13 m)	36'-6 3/32" (11.13 m)	37'-6 3/32" (11.43 m)	22'-3 5/32" (6.79 m)	24'-3 27/32" (7.41 m)	21'-7 5/16" (6.60 m)	14'-9 5/8" (4.51 m)
100'	56'-7 9/16" (17.26 m)	28'-13/16" (8.56 m)	42'-8 11/32" (13.01 m)	42'-10 11/32" (13.06 m)	26'-6 29/32" (8.10 m)	26'-3 23/32" (8.02 m)	22'-2 19/32" (6.77 m)	14'-10 3/8" (4.53 m)

A – Discharge height at 35°

B – Free clearance above wheels

C – Closest point to bin at 35° (ground level)

D – Closest point to bin at 35° (eave level)

E – Intake to lower arm attachment

F – Upper undercarriage arm length

G – Lower undercarriage arm length

H – Tread width center of tire

TRANSPORTING CONVEYOR

TRANSPORT INFORMATION

Always observe safe driving and operating practices, and comply with your local and state regulations that govern marking, towing and maximum width while transporting. **Do Not transport the conveyor at speeds greater than 20 mph (32.19 kph).**

 **WARNING! Be alert of all overhead obstructions and electrical wires, failure to do so can result in electrocution.**

 **Lower the conveyor well below the level of power lines before moving. Maintain at least 10 feet (3.05 m) of clearance (electrocution can occur without direct contact of power lines).**

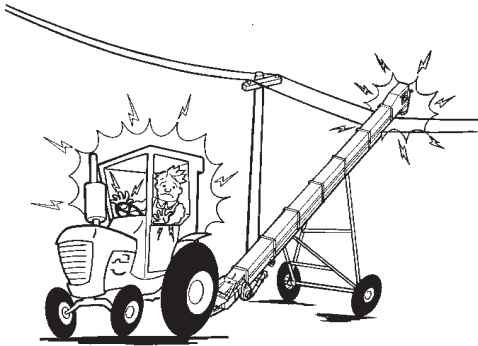

Electrocution Can Occur Without Direct Contact of Power Lines!

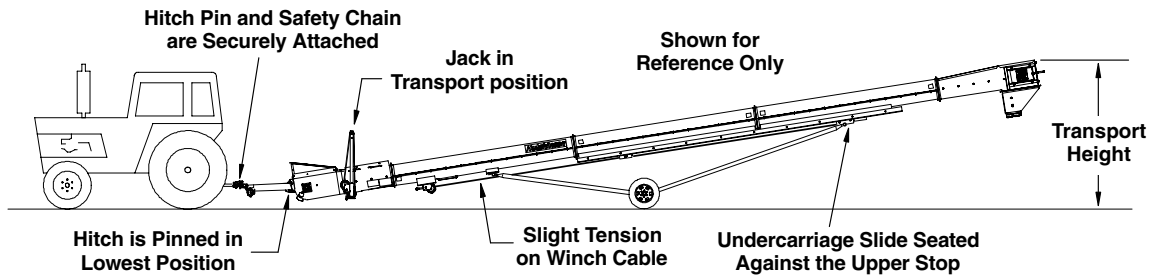

- Plan your route to avoid overhead obstructions and power lines.
- Move the conveyor with a tractor to and from the work area. A pickup truck or other suitable vehicle may be used for transporting the conveyor over great distances.
- Always transport your conveyor in the full down position.
- The undercarriage slide should be seated against the down position stop with slight tension on the winch cable (**there must be 3 complete wraps of cable around the winch drum when the conveyor is in the full down position**).
- Hitch should be secured to tractor and jack stored in its transport position (make sure to attach hitch safety chain).
- **Avoid Sharp Turns!** It is possible to hit the tractor tires or fenders.
- To prevent conveyor from upending, make sure all grain has been emptied from the conveyor before transporting.
- Before moving the conveyor, the operator should make sure all personnel are clear of the “**Moving Conveyor Hazard Area**” shown on Page 11. **Never** allow persons to stand underneath or ride on the conveyor when it is being transported.
- Know the transport height of the conveyor before moving it (see chart below).

Conveyor Length	Transport Height*	Lowered Height**	Conveyor Length	Transport Height*	Lowered Height**
40'	12'-1" (3.68 m)	13'-3 1/16" (4.04 m)	70'	15'-3 7/8" (4.67 m)	16'-6 13/32" (5.04 m)
50'	12'-1 9/32 (3.69 m)	12'-7 5/16 (3.84 m)	80'	16'-17/32" (4.89 m)	16'-10" (5.13 m)
60'	13'-8 13/32" (4.18 m)	15'-1 1/8" (4.60 m)	90'	15'-10 11/16" (4.84 m)	16'-5" (5.00 m)
65'	15'-9 29/32" (4.82 m)	16'-9 27/32" (5.13 m)	100'	21'-3 3/4" (6.50 m)	22'-8 3/4" (6.93 m)

* Transport height is with conveyor fully lowered, hitch pinned in lowest possible position and attached to a vehicle with a drawbar height of 1' - 6" (45.7 cm).

** Lowered height is with conveyor fully lowered and the boot (inlet end) resting on the ground.

CONVEYOR MOVING HAZARD AREA



WARNING! Before moving the conveyor, the operator should make sure all personnel are clear of the “Moving Hazard Area” as shown in the diagram below.

Never allow persons to ride on the conveyor while it is being transported.

Shaded area represents area to stay clear of.

Hazard Area
KEEP OUT

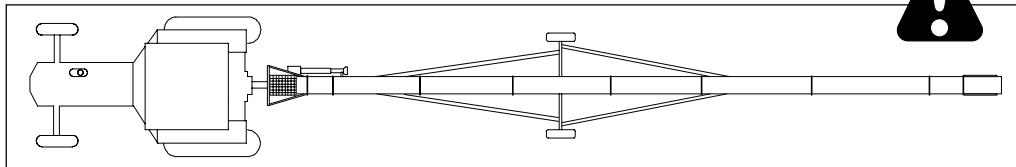

ATTACH CONVEYOR to TOWING VEHICLE



WARNING! Never stand between the tractor and conveyor when hitching unless all controls are in neutral and the brakes are locked.

Never allow persons to stand underneath or ride on the conveyor when it is being transported.

Never raise the hitch end higher than necessary to attach to the towing vehicle (weight transfers rapidly to the discharge end as the hitch end is being raised, particularly when the conveyor is in the raised position).

Two screw jacks are provided for the conveyor, one on the conveyor hitch tube, and one on the underneath side of the boot assembly (inlet hopper).

The jack on the hitch tube is used for hitching and unhitching to the tow vehicle (See Fig. 1).

1. Depending on the position of the conveyor (raised or lowered) the jack needs to be as vertical to the ground as possible when being used. Remove the safety pin from the jack stand and rotate the jack accordingly, reinstall and secure the pin once the jack is positioned (See Fig. 1).

Raise the intake end of the conveyor only high enough to allow connection to the drawbar of the towing vehicle.

The drop leg jack (See Fig. 1A) on the inlet is used to raise the inlet end so the hitch tube can be rotated in the hitch mount plates, or raised to take the weight off the hitch tube (when attached to tow vehicle) so the tube can rotate in the mounting plates when hitch location pin has been removed.

When transporting the conveyor, the hitch tube should be secured using the hole in its mounting plates that is closest to the inlet hopper (See Fig. 2 on Page 12). Using this hole will allow the conveyor, when in its full down position, to be at its lowest height possible for transport.

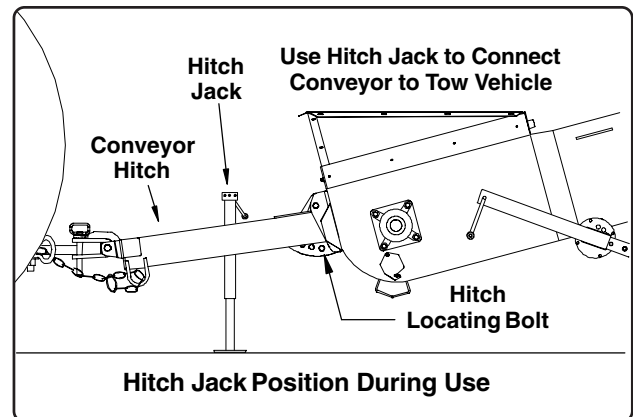

Fig. 1

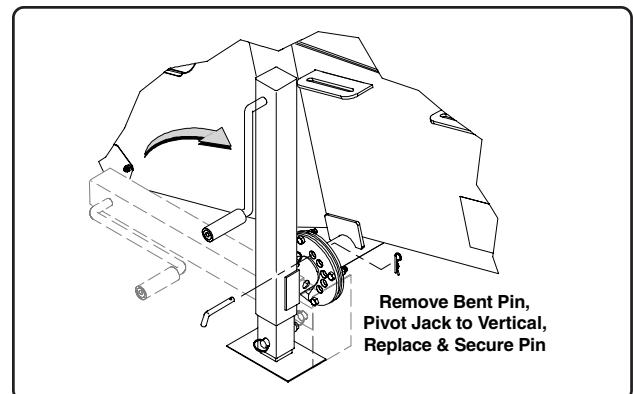

Fig. 1A

TRANSPORTING CONVEYOR

ATTACH CONVEYOR to TOWING VEHICLE (con't.)

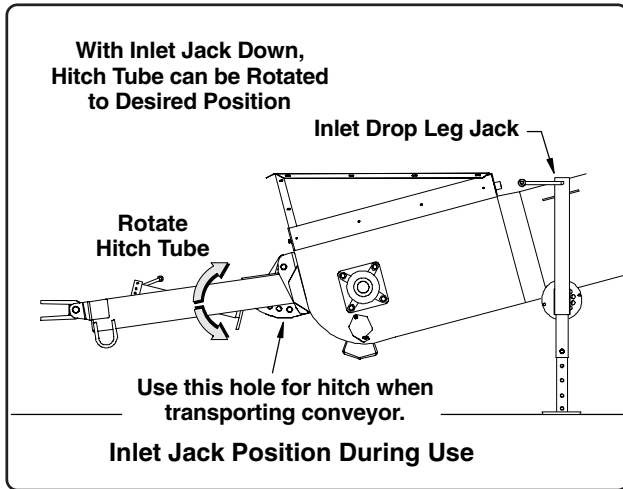

Fig. 2

- Secure the conveyor hitch clevis to tractor drawbar with hitch pin and keeper, or you can use a bolt, flat washers and two nuts. Make certain the hitch clevis is securely attached.

An auxiliary attachment system (safety chain) is required when transporting on public roads. Its function is to retain the connection between the towing and towed machines in the event of separation of the primary attachment system.

- Fasten one end of a safety chain (not furnished) to the drawbar on the towing vehicle, and the other end to the loop-anchor welded to the side of the conveyor hitch tube (See Fig. 3).

A clevis or similar type of intermediate support for the chain should be fastened to the hitch tube no farther than 6" (152 mm) from the hitch pin.

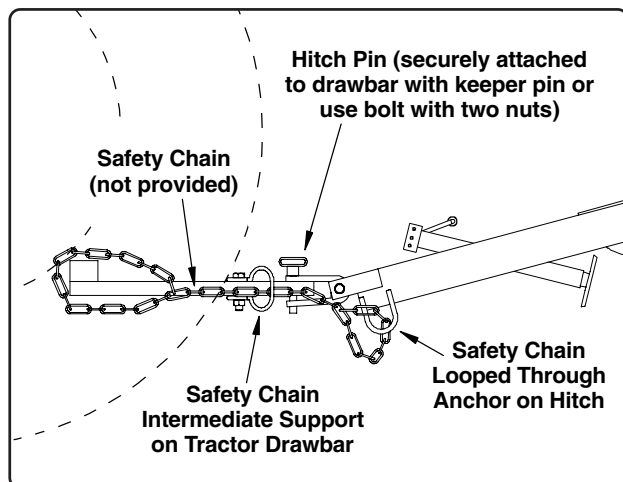

Fig. 3

- Once the conveyor has been hitched to the towing vehicle, raise the jack stand to the appropriate transport position.

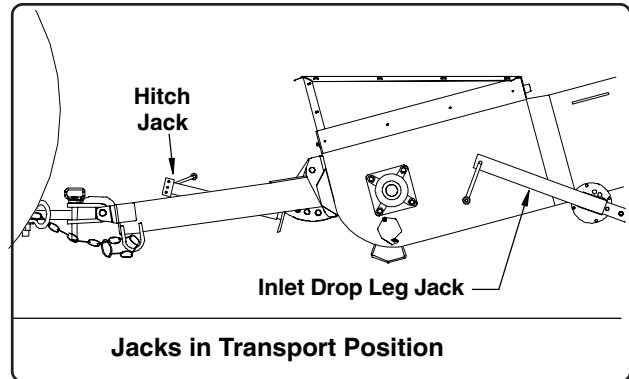

Fig. 4

PLACEMENT of CONVEYOR for FILLING GRAIN BIN



CAUTION! Make sure entire area above conveyor and the path of travel is clear of overhead obstructions and electrical wires. Failure to do so can result in electrocution, maintain at least 10 feet (3.05 m) of clearance from power lines, *electrocution can occur without direct contact of the power lines.*



To prevent tip-over when backing, avoid rolling over any obstructions and avoid steep slopes. If the conveyor is to be set on a slope, approach the bin uphill. Avoid moving the conveyor at right angles to a slope.



Make sure everyone is clear of the work area when moving the conveyor. Keep hands clear of the winch drum when winch is in operation.

- Conveyor should be placed on as level a surface as possible (the wheels must be allowed to roll freely as the conveyor is being raised).
- When positioning the conveyor into its working position, make sure to leave adequate room for the loaded vehicles to reach the inlet hopper.

PLACEMENT of CONVEYOR for FILLING GRAIN BIN (con't.)

STEP 1: Locate Conveyor Next to Bin

1. Move the conveyor into its working position with a towing vehicle (See Fig. 5). Locate the conveyor as close as possible to the bin, or other storage structure (**move conveyor slowly towards the bin with the towing vehicle - not by hand**).

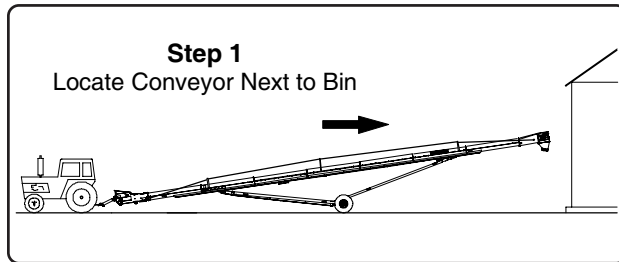
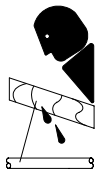

Fig. 5

STEP 2: Raise Conveyor



WARNING! Hydraulic systems are highly pressurized. Do Not connect or disconnect hydraulic components when there is pressure in the system.



Escaping hydraulic oil, even an invisible pinhole leak, can penetrate body tissues and cause severe injury.

If injured by hydraulic oil escaping under pressure, see a doctor at once. Serious infection or reaction may occur if medical attention is not received immediately.

1. Raise the inlet end of the conveyor with the drop leg jack to relieve pressure on the hitch locating bolt (See Fig. 6). Remove the locating bolt and using the drop leg jack, lower the inlet end to the ground.
2. Leave the locating bolt out. Connect the hydraulic hoses from the conveyor winch to the tractor and raise the discharge end of the conveyor high enough to clear the top of the bin (40'-65' models use a hand crank winch). **Keep hands clear of the winch drum when winch is in operation.**

IMPORTANT! Observe the cable as it is winding onto the winch drum. The cable should roll up on the drum evenly, avoid cable buildup on one side of the drum.

Do Not block or restrict the movement of the tires. The wheels must be allowed to roll freely as the conveyor is being raised.

3. Reposition the drop leg jack so it is vertical to the ground. Raise the inlet end just high enough to allow the locating bolt to be reinserted into the first available hole (this will allow the inlet end to be slightly above the ground).

4. Raise the jack stand so the conveyor can be moved without dragging the jack on the ground.

Check to make sure the conveyor discharge spout remains high enough to clear the top of the bin.

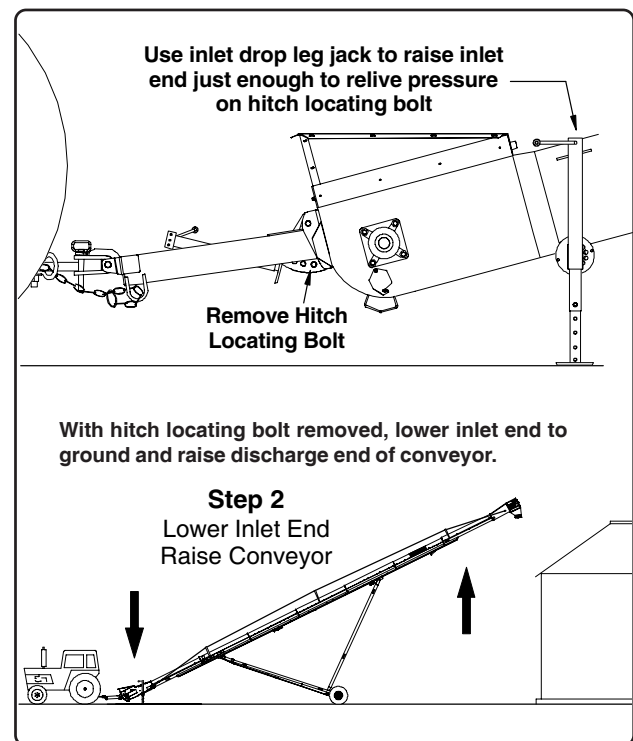

Fig. 6

TRANSPORTING CONVEYOR

PLACEMENT of CONVEYOR for FILLING GRAIN BIN (con't.)

STEP 3: Back into Position

1. After raising the inlet end off the ground, back the conveyor slowly into working position with the towing vehicle (See Fig. 7). **Never move the conveyor by hand, always use a vehicle.**

Do Not attempt to increase conveyor height by positioning its wheels on lumber, blocks or any other means to raise its height.

2. Continue backing the conveyor until the discharge spout is directly over the bin opening (**when positioning the discharge over the bin opening, keep in mind that the discharge end will lower a few inches as the conveyor fills with grain**). When discharging into a grain spreader, maintain at least 12" (30.5 cm) of space between the discharge and the spreader.

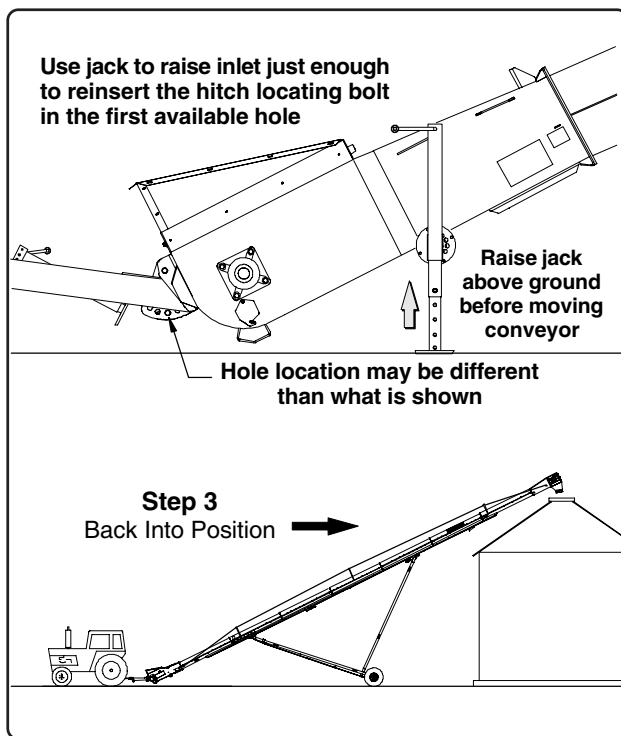

Fig. 7

STEP 4: Lower Inlet End to Ground

1. With the discharge directly over the opening, use the hitch jack to take pressure off of the hitch locating bolt and remove the bolt (See Fig. 7A).
2. Lower the inlet hopper to the ground and check discharge spout position. If necessary, reposition and/or lower conveyor so spout is directly above opening when intake is resting on the ground.

Use drop leg jack to raise inlet just enough to remove the hitch locating bolt and lower inlet end of conveyor to ground

Step 4
Lower Inlet End to Ground and Unhitch

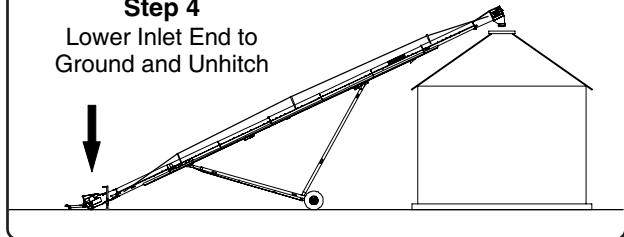

Fig. 7A

3. Chock the conveyor wheels to prevent the conveyor from rolling. Disconnect tractor from conveyor as detailed below.



CAUTION! Never stand between the tractor and conveyor when hitching or unhitching, unless all controls are in neutral and the brakes locked.



Never raise the intake end higher than necessary to attach to a towing vehicle. Weight is transferred rapidly to the discharge end when the intake is raised, especially when conveyor is in the raised position.



Persons operating, servicing or repairing equipment that requires above ground work shall be properly secured with the use of "fall protection" equipment as set forth by OSHA guidelines and regulations.

4. Position the hitch jack vertical to the ground. Raise the inlet end just high enough to remove the hitch weight from the tractor drawbar. Remove safety chain and tractor hitch pin.

If hydraulic hoses were attached for winch operation, make sure they are disconnected before moving the tractor from the area.

NOTE: It is good practice to secure the discharge end of the conveyor to the bin or storage structure to prevent possible wind damage (remember to disconnect any tie-downs and/or anchors before moving the conveyor away from the bin).

5. Make sure all clean-out doors, access panels and safety guards are in place before beginning grain transfer operations.

RELOCATION OF CONVEYOR

When grain conveying is completed, the conveyor should be moved away from the bin and lowered. It can then be moved to a different bin for more conveying operations, or it can be cleaned-up for storage.



CAUTION! Never stand between the tractor and conveyor when hitching or unhitching, unless all controls are in neutral and the brakes locked.



Never raise the intake end higher than necessary to attach to a towing vehicle. Weight is transferred rapidly to the discharge end when the intake is raised, especially when conveyor is in the raised position.

STEP 1: Raise Conveyor

1. Empty all grain from the conveyor and clean up the work area. Loosen the wingnut on the small hopper door located on the lower right side of the inlet hopper and clean excess grain from hopper.
2. Untie any anchors and/or supports that were used to help secure the conveyor.
3. Disconnect the power source. Electric units, unplug all electrical cords and store them so they cannot become damaged during transport. PTO drive units, place PTO driveline into the storage/transport bracket and secure for transport.
4. If the hitch tube was removed, reinstall it to the conveyor. Using the hitch jack, raise the inlet end just high enough to attach the hitch to the tractor drawbar and install the safety chain (See Page 12 for safety chain information).

Connect the hydraulic winch hoses to the tractor's hydraulic system (70' thru 100' units only).

5. Remove the wheel chocks and raise conveyor until the discharge spout clears the top of the bin.
6. Once conveyor is ready, move the conveyor slowly away from the grain bin with the towing vehicle. **Never attempt to move conveyor by hand, always use a vehicle.**

STEP 2: Lower Conveyor

1. Immediately after conveyor has cleared the bin or storage structure, lower the conveyor to its full down position. **IMPORTANT! Lower the conveyor to its full down position even if only relocating to another bin.**

2. Use the drop leg jack to raise inlet just far enough to relieve pressure on the hitch locating bolt. Raise inlet until locating bolt can be reinserted into the front hole used for transporting the conveyor (See Fig. 2 on Page 12).

STEP 3: Move to Next Bin or Storage

1. Disconnect and secure the hydraulic winch hoses so they will not become damaged during transport.
2. Move conveyor to next bin or storage site, or prepare the conveyor for storage (conveyor should be stored in the full down position).

If the conveyor will be stored outside, make sure the small inlet hopper door on the lower right side of the hopper remains open (this will allow rain water, melted snow, etc. to drain from the hopper).

3. Follow the machine inspection recommendations on Page 6 before operating conveyor again.

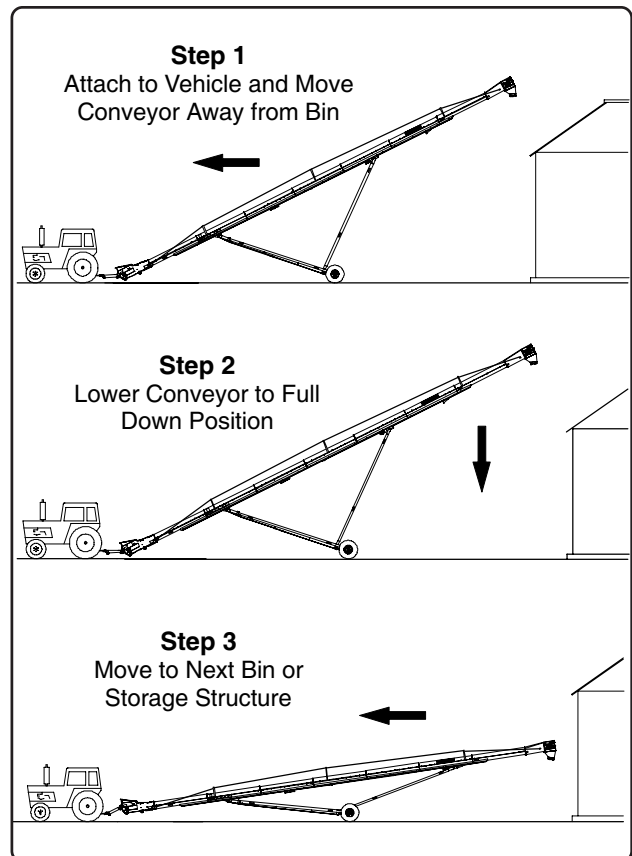

Fig. 8

CONVEYOR OPERATION

DESIGNATED WORK AREA



WARNING! Under no circumstances should persons not involved in the operation be allowed to trespass into the work area. It shall be the duty of all operator's to see that children and/or other persons stay out of the work areas. Trespassing into the work area by anyone not involved in the actual operation, or trespassing into a hazard area by anyone shall result in immediate shutdown by the operator.



It shall be the responsibility of the operator's to see that the work area has secure footing, is clean and free of all debris and tools which might cause accidental tripping and/or falling. It shall also be their responsibility to keep the work area clean and orderly during the operation.



Use caution when working in areas above the ground. Persons operating, servicing or repairing equipment that requires above ground work shall be properly secured with the use of "fall protection" equipment as set forth by OSHA guidelines and regulations.

Metal buildings, scaffolding and other types of work surfaces can become slippery, especially when surfaces are wet and/or oily. This can create hazardous working conditions. Use caution when working, climbing or walking on these surfaces.

Before starting the conveyor, a designated work area should be established and properly marked. The following diagram shows the manufacturers designated work area for conveyor operation.

These areas shall be marked off with colored nylon or plastic rope or banners hung as portable barriers to define the designated work area.

All operator's shall know how to shutdown and lockout the equipment in the event of an emergency.

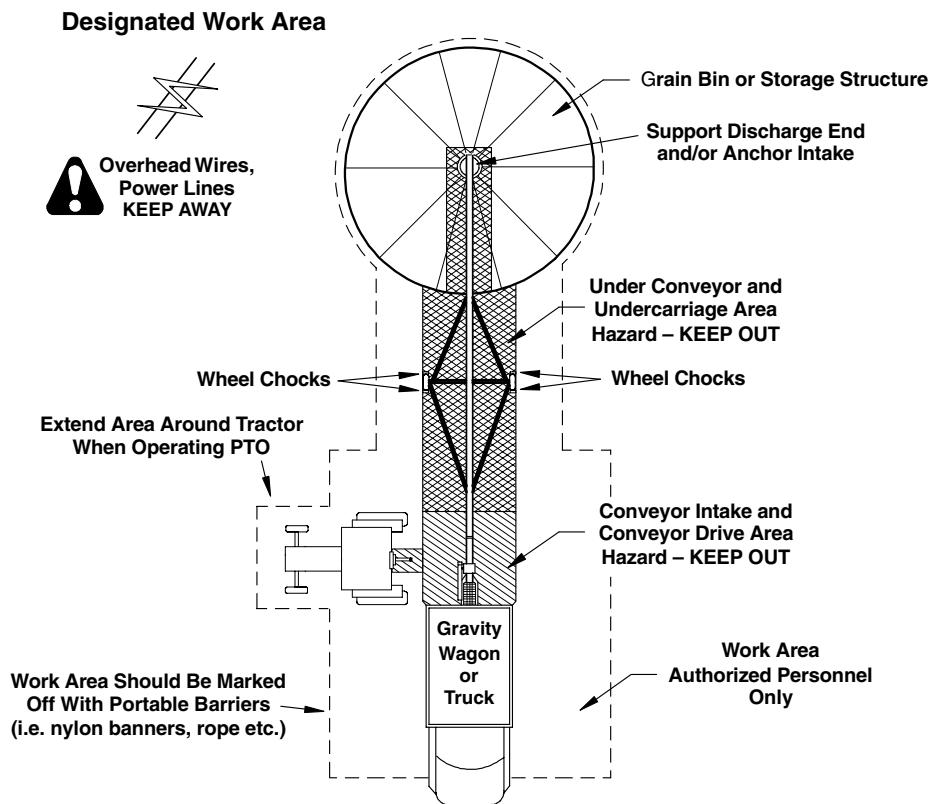

Be cautious of slippery surfaces. Make sure area is clear of tools, debris, or other items that may trip you or create a hazardous situation.

OPERATING PROCEDURES (ELECTRIC DRIVE MODELS)



WARNING! The operator shall be aware of any unusual vibrations, noises and the loosening of any fasteners.

Keep all safety shields and devices in place.

Keep hands, feet and clothing away from moving parts.



The operator shall have a full view the conveyor work area and check that all personnel are clear of hazard areas before adding power.



A main power disconnect switch that can be locked in only the “Off” position shall be provided. This shall be locked whenever work is being done to the conveyor.

The reset and starting controls must be located so that the operator has full view of the entire operation.



Disconnect power before resetting motor overloads. Make certain electric motor is grounded.

Shut off power and lockout whenever cleaning or servicing the conveyor.

Check the following before adding power:

- All safety devices are in place and properly fastened, and the clean-out door on bottom of hopper is in place.
- Drive belts are properly tightened and in good condition, Replace belts if they are cracked, frayed, or damaged in anyway.
- Check electrical cords to ensure they are in good condition. Replace if necessary.
- Check electric power box and controls. Verify the power source can be locked out.
- Ensure conveyor is properly positioned and work area is appropriately marked and free of tools, debris and other hazards.
- Verify all drive component hardware and fasteners are tight, i.e. motor mount, pulleys, setscrews etc.

Begin Grain Conveying Operations

1. Start the electric motor and check to make sure conveyor is running properly.
2. Slowly begin filling the inlet hopper with grain until desired flow rate is achieved.

ELECTRIC DRIVE SHUTDOWN/LOCKOUT



WARNING! If the operator must leave the work area, or whenever servicing or adjusting, the conveyor must be stopped and the power source turned off and locked out.



Precaution should be made to prevent anyone from operating the conveyor when the operator is away from the work area.

Emergency Shutdown

Should the conveyor be immediately shutdown under load, **disconnect and lockout the power source.**

Clear as much grain from the hopper and conveyor as you can. Use the clean-out door in the bottom of the hopper to help clean grain from this area.

When as much grain as possible has been cleared, reconnect the power source and clear the conveyor gradually.

Never attempt to restart conveyor when full of grain. Starting the unit under load may result in damage to the conveyor, such damage is considered abuse and is not covered by warranty.

Normal Shutdown

Make certain that the hopper and conveyor are empty before stopping the unit. **Before the operator leaves the work area, the power source shall be locked out** (See “Lockout” below).

Intermittent Shutdown

When a conveyor is stopped and restarted under full load, it may result in damage to the conveyor. Therefore if intermittent operation is to be carried out, it is advisable to reduce the load level.

When kept from absolute filling, conveyor start-up is easier and operation more efficient.





Lockout

The power source for electric units shall have a main disconnect box that can be locked only in the “Off” position. That is what “shutdown and lockout” refers to - Shut off the main power source and lock the handle or breaker switch in the “Off” position.

CONVEYOR OPERATION

OPERATING PROCEDURES

(PTO DRIVE MODELS)

	<p>WARNING! The operator shall be aware of any unusual vibrations, noises and the loosening of any fasteners.</p> <p>Keep all safety shields and devices in place.</p>
	<p>Keep hands, feet and clothing away from moving parts.</p> <p>The operator shall have a full view the conveyor work area and check that all personnel are clear of hazard areas before adding power.</p>
	<p>Shut off power and lockout whenever cleaning or servicing the conveyor.</p> <p>Before starting tractor, be certain power to the PTO is off.</p>
	<p>Be certain the PTO driveline is securely attached to the conveyor and tractor.</p> <p>Use a PTO with a rotating shield in good working condition that can be turned freely on the shaft.</p>
	<p>Stay out of designated hazard area of an operating PTO.</p>

Check the following before adding power:

- All safety devices are in place and properly fastened, and the clean-out door on bottom of hopper is in place.
- Make sure tractor is parallel to conveyor with PTO driveline as horizontal as possible.
- Ensure conveyor is properly positioned and work area is appropriately marked and free of tools, debris and other hazards.
- Verify all drive component hardware and fasteners are tight. Check drive belts for proper tension and that they are in good condition.



Begin Grain Conveying Operations

1. Engage PTO at a slow RPM to minimize shock loads, then work up to recommended RPM. Make sure conveyor is running properly.

The conveyor can be operated at speeds from 450 to 540 RPM's. Do Not attempt full load operation at speeds below 450 RPM as high torque requirements may damage the conveyor.

2. Slowly begin filling inlet hopper with grain until desired flow rate is achieved.

PTO DRIVE SHUTDOWN/LOCKOUT

	<p>WARNING! If the operator must leave the work area, or whenever servicing or adjusting, the conveyor must be stopped and the power source turned off and locked out.</p>
	<p>Precaution should be made to prevent anyone from operating the conveyor when the operator is away from the work area.</p>

Emergency Shutdown

Should the conveyor be immediately shutdown under load, **disconnect and lockout the power source.**

Clear as much grain from the hopper and conveyor as you can. Use the clean-out door in the bottom of the hopper to help clean grain from this area.

When as much grain as possible has been cleared, reconnect the power source and clear the conveyor gradually.

Never attempt to restart conveyor when full of grain. Starting the unit under load may result in damage to the conveyor, such damage is considered abuse and is not covered by warranty.

Normal Shutdown

Make certain that the hopper and conveyor are empty before stopping the unit. **Before the operator leaves the work area, the power source shall be locked out** (See "Lockout" below).

Intermittent Shutdown

When a conveyor is stopped and restarted under full load, it may result in damage to the conveyor. Therefore if intermittent operation is to be carried out, it is advisable to reduce the load level.

When kept from absolute filling, conveyor start-up is easier and operation more efficient.

Lockout

Stop PTO and turn off power source. Remove ignition key from power source (if this is not possible, remove the PTO driveline from the work area).

GENERAL MAINTENANCE INFORMATION



WARNING! Shut off power and lockout before attempting to adjust, service, clean or repair the conveyor or any of its components.

Keep hands, feet and clothing away from moving parts.



Make sure all safety devices, shields and guards are in place and functional. Immediately replace any that are damaged or missing.

Never rely solely on mechanical or hydraulic jacks for support. Use jack stands or equivalent for support.



Never operate the conveyor with access doors or panels open.



WARNING! Hydraulic systems are highly pressurized. Do Not connect or disconnect hydraulic components when there is pressure within the hydraulic system.

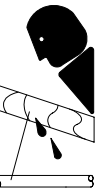

Escaping hydraulic oil, even an invisible pin hole leak can penetrate body tissues and cause serious injury.

Use a piece of wood or cardboard when searching for leaks, Never use your hands or other parts of your body.



If injured by hydraulic oil escaping under pressure, see a doctor immediately. Serious infection or reaction can occur if medical attention is not received at once.

For economical and efficient operation of your conveyor, maintain regular and correct lubrication, maintenance and service schedules. Neglect leads to reduced efficiency, excessive wear and needless down time.

Any parts needing replacement should be replaced with parts of the same type and size. **Do Not modify or alter any of the conveyor components.**

GUARDS

Check the guards to see if they are properly adjusted and securely fastened.

Guards should not be rubbing against pulleys, belts, chains or sprockets. **Immediately replace any worn or damaged guards.**

BEARING LUBRICATION

HEAD & INLET HOPPER BEARINGS

The head bearings are located on the head section at the discharge end of the conveyor (one bearing on each side of the head section).

The inlet hopper bearing is located on the right hand side of the inlet hopper.

These bearings are fitted with grease zerks (lubrication fittings) and should be lubricated approximately **once annually**.

Before greasing the bearings, make sure the zerks are free of dirt, otherwise the dirt will be passed into the bearing race which can cause contamination resulting in bearing failure.

Use an SAE multi-purpose type grease.

Normally only one to two pumps of the grease gun is sufficient when servicing the bearings. **NOTE: Over greasing can be just as harmful as under greasing if it forces grease out of the bearing seals.**

The bearings themselves do not require adjustment, but check to make sure the hardware securing the bearings is tight. Also check the setscrews in the lock collars to ensure they are tight against the shaft.

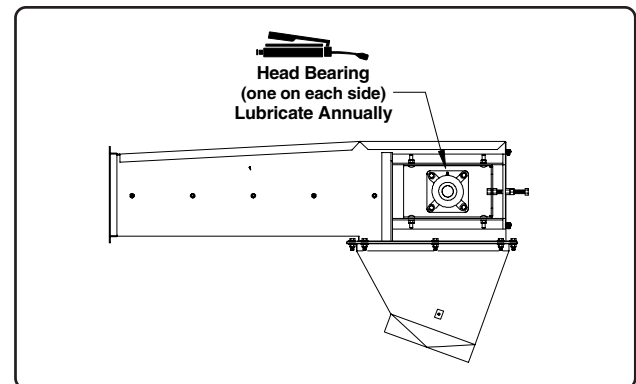

Fig. 9

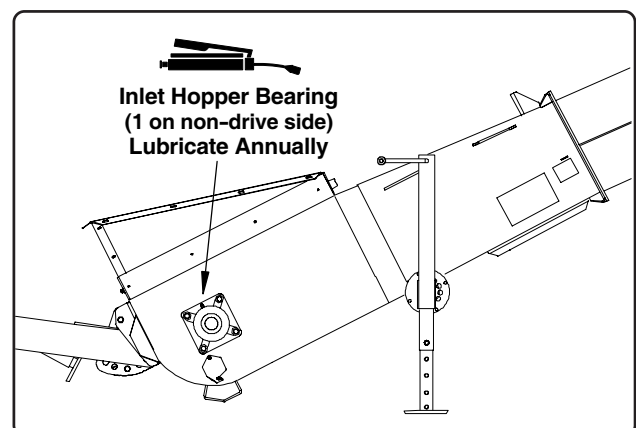



Fig. 10

LUBRICATION & MAINTENANCE

BEARING LUBRICATION (con't.)

UNDERCARRIAGE AXLE BEARINGS

 **WARNING!** Do Not rely solely on hydraulic or mechanical jacks for support. Use jack stands or equivalent to support undercarriage axle.

Tapered roller bearings are standard on all conveyor axles and should be **repacked with grease annually, or as needed determined by usage.**

To Repack Wheel Bearings:

1. Raise the undercarriage axle high enough to allow the tire to clear the ground (**only raise one side of the axle at a time**).

Place jack stands or equivalent beneath the axle for support and remove the tire.

2. Remove the dust cover by prying around the edges, (See Fig. 11) then remove the cotter pin, slotted nut and flat washer from the end of the axle shaft.

3. Carefully remove the hub from the shaft being careful so the outer bearing doesn't fall to the ground. Clean the bearing with solvent and inspect the bearing for wear and damage, replace if necessary.

To inspect the inner bearing you will need to remove the seal from the rear of the hub (the seal may become damaged during this procedure, replace as necessary, see parts identification above).

With the seal removed, you can now remove the inner bearing from the hub. Clean the bearing with solvent and inspect it for wear and damage. Replace if necessary.

4. Clean the hub cavity with solvent before reassembly. Using a good **automotive type axle grease**, repack the inner bearing. Insert the inner bearing into the hub and press on the grease seal.

5. Reinstall the hub onto the axle shaft being careful not to damage the lip of the seal during installation.

6. Repack the outer bearing. Fill the hub cavity with grease until about 1/3 full, then install the outer bearing.

7. Reinstall the flat washer and the slotted nut. Tighten the nut to seat the bearings. Keep tightening the nut until the hub begins to bind as it is being rotated. Back off the nut to the next slot and install a new cotter pin (5/32" x 1 3/4" for 50' thru 100' Models and 5/32" x 1 1/4" for 40' Models). Reinstall the dust cap and remount the tire.

Repeat this procedure on the opposite wheel hub.

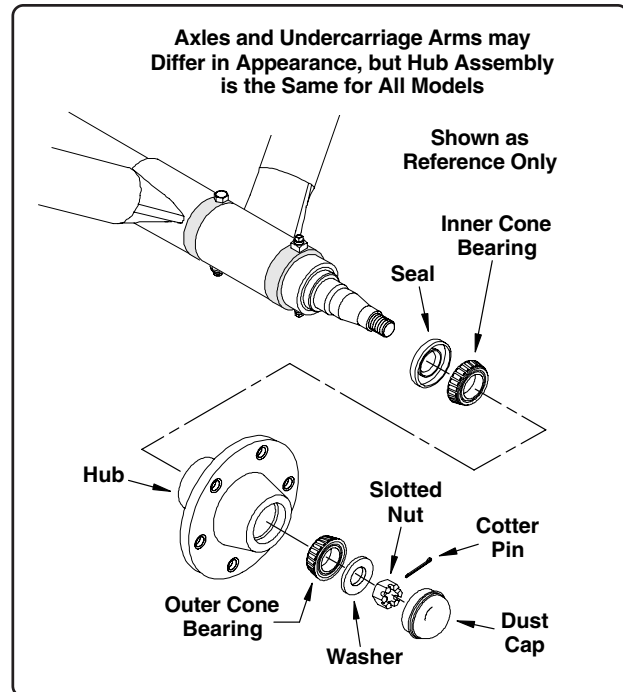

Fig. 11

HITCH JACK & DROP LEG JACK LUBRICATION

1. A grease zerk (lubrication fitting) is located on the handle side of the **hitch jack**. Use a good quality SAE multi-purpose grease and **lubricate annually**.
2. Extend the legs on the **drop leg jack** and lubricate the legs with a spray type lubricant or apply a thin layer of a good quality multi-purpose grease. **Lubricate annually.**

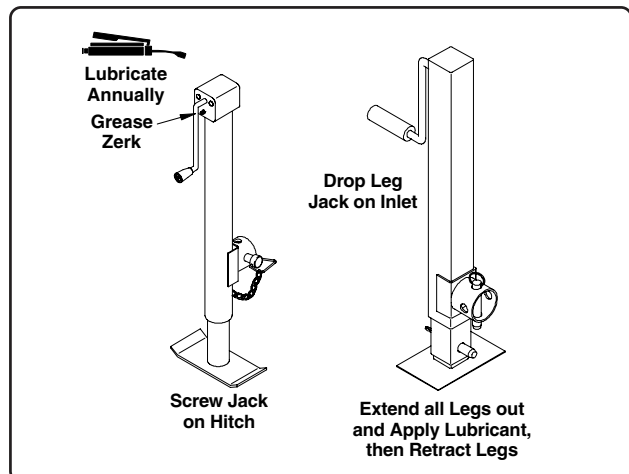

Fig. 11A

TIRES

Tires can eventually become weathered from sitting outside season to season. Check tires periodically for damage such as cracking, uneven wear, as well as low tire pressure. Repair or replace as needed.

Proper tire pressure not to exceed **45 PSI (310 kPa)**.

DRIVE BELTS (ELECTRIC & PTO DRIVE)

All belts need to be checked and adjusted periodically to assure all belt driven components are performing properly. Belt tension must be sufficient to avoid any slipping or abnormal wear during conveyor operation.

Do Not overtighten the belts. Overtightening creates high stress on the belts and conveyor components and can result in excessive vibration. This vibration can result in damage to the conveyor components.

Check to see that correct alignment of the sheaves and belts is maintained. Check that all sheaves are secured on their shaft, drive key is in place and the setscrews are tight.

Adjust Belt Tension:

1. **Electric Models:** Loosen the four (4) carriage bolts securing the feet of the motor mount plate to the brackets on the conveyor housing (See Fig. 12).

PTO Models: Loosen the four carriage bolts securing the PTO housing to the mount brackets on the side of the conveyor housing, **and** loosen the two 5/16" bolts securing the belt guard to the PTO housing (See Fig. 13).

2. **All Models:** Locate the 3/4" threaded adjustment rod attached to the front of the motor mount plate (See Fig's. 12 and 13).
3. Note the two (2) 3/4" nuts securing the threaded rod to the adjustment bracket. Loosen the nut on the back side of the bracket and thread the nut back a couple of inches..

Turn the nut on the front side of the bracket until proper belt tension has been achieved. **Proper tension is 9/16" of deflection per belt when using 7.5 lbs. of force at the center of the span between the two sheaves.**

After 24 hours of operation, and for the remainder of belt life, deflection should be 9/16" using 4 to 5.5 lbs. of force. If you do not have a weight set to apply the recommended amount of force, a fish scale is a good alternative. Tension can also be checked by pressing firmly on the belts at the center of the span between the two sheaves.

Electric Drive Models

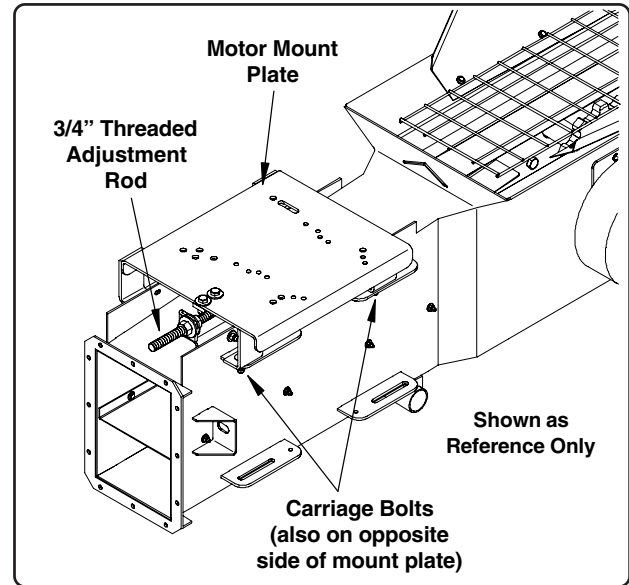

Fig. 12

PTO Drive Models

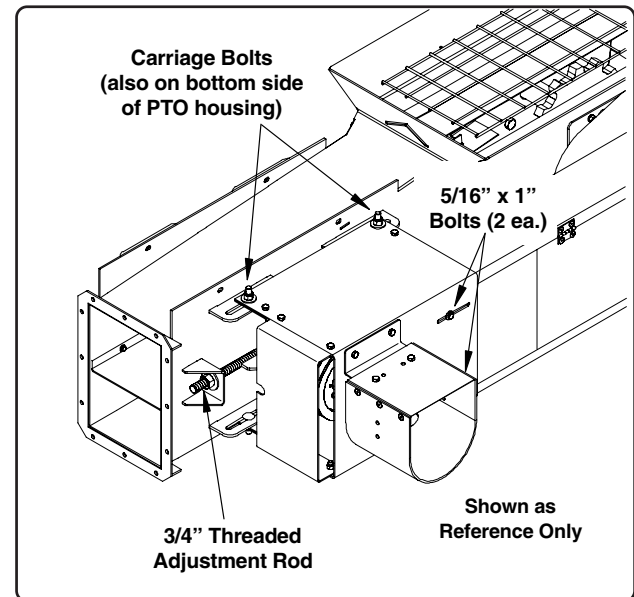

Fig. 13

LUBRICATION & MAINTENANCE

WINCH MAINTENANCE



CAUTION! Keep hands away from winch drum and cable during winch operation.

Never fully extend the cable, always leave a minimum of three wraps of cable around the winch drum.



If brake disc mechanism operates intermittently or erratically, brake disc inspection should be performed.

Hand Operated Winch (40'-65' Models)

CAUTION: The cable keeper alone will not hold the weight of the conveyor. There should be enough cable so that when the conveyor is in its full down position, there is a minimum of three (3) cable wraps around the winch drum.

Lubrication

All gears must be clean and lubricated (auto-type grease) to insure proper and safe operation.

All shafts, bushings and ratchet parts must be clean and wet with oil (use a 10W-30 automotive oil).

Brake Disc

Inspect brake disc for wear and/or damage. Brake disc's should be replaced if they are cracked, broken, or if the thickness is less than 1/16" (2 mm). **Do Not use oil or grease on fiber brake faces.**

Brake Ratchet Mechanism

Check ratchet operation by listening for "clicking sound" when cable is reeled in (handle turned clockwise). When the cable is reeled out, there is no clicking sound.

Replace any worn or damaged parts before operating the winch.

Hydraulic Operated Winch (Available for All Models)

IMPORTANT! Although the winch is shipped with oil already added to the gearbox, we recommend checking oil level before operation.

With winch in level position, remove one of the plugs located around the gearbox, if oil begins to leak from opening, level is good. Add oil accordingly.

If additional oil is needed, use an **SAE 85W140** non-foaming multipurpose gear oil. Use a grade/brand that is commercially available for automotive differentials. Extra pressure additives may be of some value in more severe applications. **Do Not overfill. Too much oil may damage the seals.**

Capacity is: 8 oz. (.24 L)



WARNING! Hydraulic systems are highly pressurized. Do Not connect or disconnect hydraulic components when there is pressure within the system.

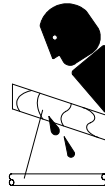

Escaping hydraulic oil, even an invisible pin hole leak can penetrate body tissues and cause serious injury.

Use a piece of wood or cardboard when searching for leaks, Never use your hands or other parts of your body.

If injured by hydraulic oil escaping under pressure, see a doctor immediately. Serious infection or reaction can occur if medical attention is not received at once.



- Check hoses, fittings and connectors for leaks. Repair or replace as necessary.
- Allow hoses to coil in their original shape. Avoid pinching, crimping or twisting the hoses that would otherwise restrict the flow of the hydraulic system.
- **IMPORTANT! Keep hydraulic hoses away from moving parts. Make sure to secure the hoses in a manner that they cannot become damaged when transporting the auger.**
- When not in use, make sure the fittings on the end of the hoses are protected from dirt and other contaminants.
- The fittings required for attaching the hoses to the tractor are not furnished. **Two (2) 1/2" NPT female fittings are needed for attaching hose ends to the tractor fittings.**

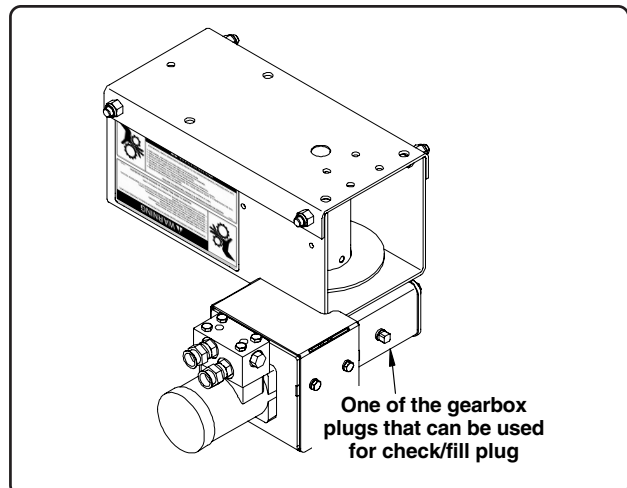

Fig. 14

WINCH MAINTENANCE (con't.)



WARNING! Shut off power and lockout power source before attempting to adjust, service, clean or repair the winch or any of its components.

Electric motors and controls shall be installed by a qualified electrician and must meet the standards set by the National Electric Code and all local and state codes.

A main power disconnect switch capable of being locked in only the “Off” position shall be used. This shall be locked whenever work is being done to the equipment.

Electric Operated Winch (40' - 65' Models)

An optional electric winch is available for the 40' to 65' Models. **IMPORTANT!** The 1006526 Winch requires a dedicated 110V, 20 AMP circuit. Also any power cord over 25' (7.62 m) must be a 10-3 wire. 12-3 is okay for cords less than 25' (7.62 m).

Although the winch is shipped with oil already added from the factory, it is recommended to check oil level before operation.

If additional oil is needed, use an **SAE 85W140** non-foaming multipurpose gear oil. **Do Not overfill the gearbox, too much oil can damage the seals.** There are numerous plugs around the gearbox which the oil can be checked or filled from. With winch as level as possible, remove one of the plugs, oil should leak from the opening. If it does not, add oil until it begins to leak from the opening. **Capacity: 8 oz. (.24 L).**

There is also a grease zerk located on the gearbox near the shaft for the motor sheave. Use 1 to 2 pumps of a good quality SAE multi-purpose grease annually.

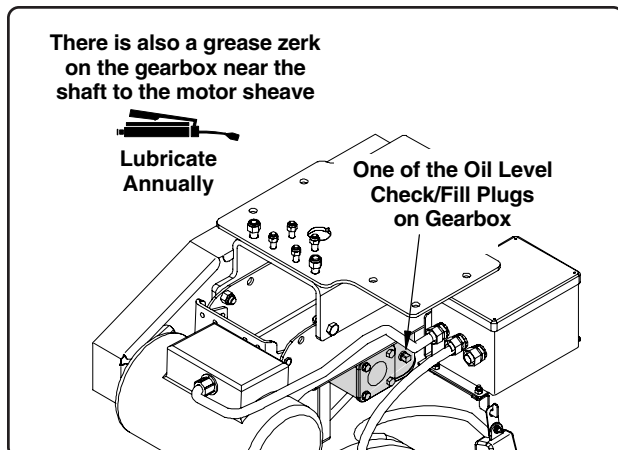

Fig. 15

Electric Operated Winch (70' - 100' Models)

The winch is designed to be connected to a **220 volt electrical power system.**

IMPORTANT! The electric winch is shipped with oil already added to the gearbox. It is necessary to install the vent/fill plug that is shipped with the winch. Remove the plug from the top of the gearbox and install the vent/fill plug (See Fig. 16).

Check oil level before operation. To check oil level in the winch gearbox. Position the winch as horizontal as possible. Remove one of the plugs from the side of the gearbox. Oil should begin to flow from the opening.

If additional oil is needed:

1. Remove the vent/fill plug from the top of the gearbox and remove one of the plugs from the side of the gearbox.
2. Add an **EP 85W140** non-foaming multipurpose gear oil into the top vent/fill plug opening until oil begins to leak from the opening in the side of the gearbox. Reinstall the plugs (See Fig. 16).

Do Not overfill the gearbox. Too much oil can damage the seals.

3. To drain oil, remove the vent/fill plug from the top of the gearbox and the plug on the bottom of the gearbox. After oil has drained, replace the plug on the bottom of the gearbox.

Remove the level check plug from the side of the gearbox. Add oil through the vent/fill port until oil begins to leak from the level check opening in the side, **approx. 46 oz. (1.36 l).** Replace plugs.

Dispose of used oil according to your local ordinances.

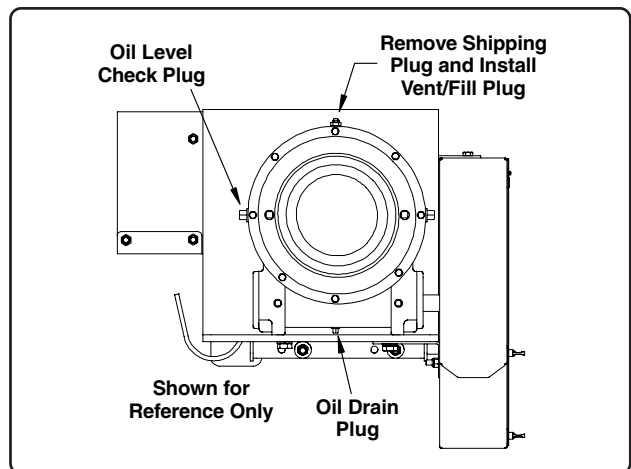

Fig. 16

LUBRICATION & MAINTENANCE

WINCH MAINTENANCE (con't.)

Winch Belt Adjustment f/ 40' to 65' Models

1. Open the belt guard cover. Check belt for fraying, cracking or other damage. Replace as necessary.
2. Check belt for proper tension. Belt should deflect approximately 1/2" (13 mm) when pressed firmly in the center of the span between the two sheaves.
3. To adjust belt tension, loosen the four bolts securing the motor mount plate (See Fig. 17).

Using a pry bar, piece of wood or similar object, pry the motor mount plate out to achieve proper tension. After proper tension has been established, retighten the four bolts to secure motor into place.

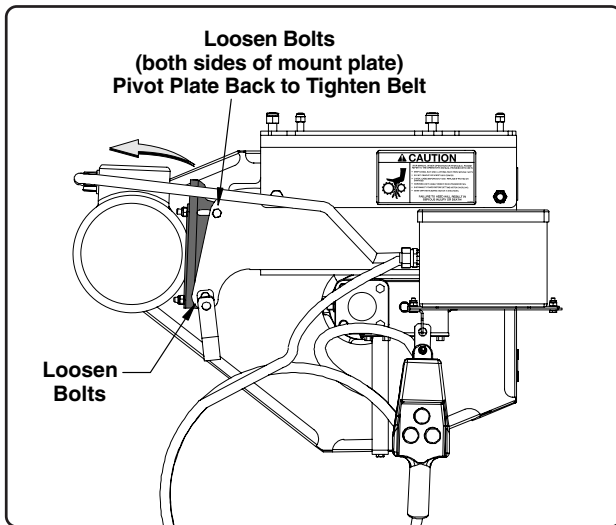

Fig. 17

See the "Electric and Hydraulic Winch Mount" section in the assembly procedures for electric winch operation.

Grease Winch Bearing f/ 70' to 100' Models

1. The flange bearing will need to be lubricated periodically, usually **once before each season of operation** is adequate.
2. The bearing can be accessed from the bottom side of the winch motor mount frame (See Fig. 18).

Before greasing the bearing, make sure the grease zerk is free of dirt, otherwise the dirt will be passed into the bearing race which can cause contamination resulting in bearing failure.

Use a good quality multi-purpose lithium based grease. Normally **1 to 2 pumps** is sufficient when lubricating the bearing. **NOTE: Over greasing can be just as harmful as under greasing if it forces grease out the bearing seals.**

The bearing itself does not require any adjustment, but check to make sure the hardware securing the bearing is tight. Also check the locking collar to ensure it is properly secured.

Winch Belt Adjustment f/ 70' to 100' Models

1. Open the belt guard cover and check belts for fraying, cracking or other damage. Replace as necessary.
2. Check belts for proper tension. Belts should deflect approximately 1/2" (13 mm) when firmly pressed in the center of the span between the two sheaves.
3. To adjust belt tension, loosen the four bolts securing the motor mount plate, two bolts at top and two bolts at bottom (one of the top bolts is also used to secure the belt guard bracket as shown in Fig. 18).

Using a pry bar, piece of wood, or similar object, pry the motor mount plate out to achieve proper tension (the pry bar can be inserted from the bottom side of the motor mount plate). After proper tension has been set, retighten the four bolts. Close and secure the belt guard cover.

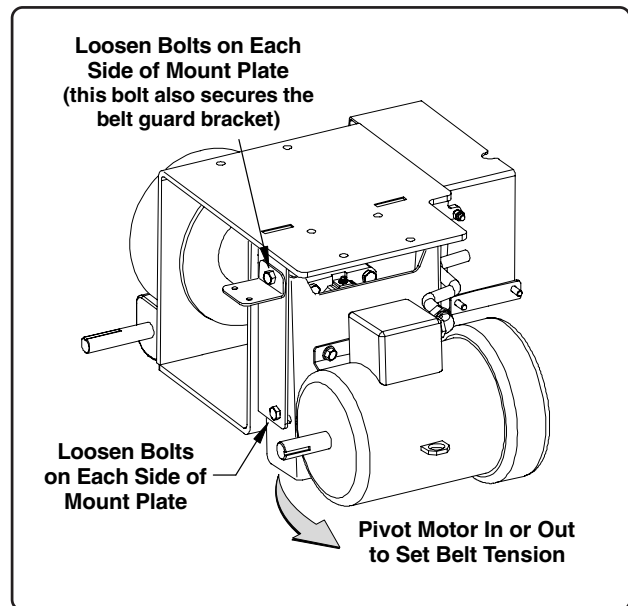



Fig. 18

GEARBOX LUBRICATION



WARNING! Keep all safety shields and devices in place.
Never clean, adjust or lubricate a machine that is in operation.

IMPORTANT! The gearbox is shipped *without* oil. Oil needs to be added *before* operation of the conveyor.

Even under normal working conditions, oil will still dissipate. Check oil level in gearboxes periodically and maintain proper level.

Lubrication is extremely important. For satisfactory operation, follow the information shown on the gearbox nameplate, its warning tag and in the manual provided with the gearbox.

Failure to observe these precautions could result in damage to the equipment.

CAUTION: Too much oil will cause overheating and too little oil will result in gear wear and failure. Check oil level regularly.

Oil should be changed more frequently when conveyor is being operated at high temperatures, under extreme dirty conditions, or when operated continuously.

Under these extreme conditions the oil should be changed every **1 to 3 months**, depending on severity of the conditions.

Very often, small metal particles will show up in the oil due to the wearing process. A magnetic drain plug is provided to help contain the particles.

1. With conveyor in the full down position, remove the vent/fill plug from the top of the gearbox and the level check plug as determined by the angle of conveyor shown in Fig. 19.

Add **approx. 48 oz. (1.42 l)** for 40' to 70' Models, or **approx. 128 oz. (3.78 l)** for 80' to 100' Models, of an **SAE 90 weight*** high grade petroleum base, rust and oxidation inhibited (R&O) gear oil to the gearbox until it begins to flow from the level check opening. Reinstall plugs.

Oil level should be checked each time with the conveyor in the same position as when oil level was initially checked.

Recommended Oil:

SAE 90 weight*, high grade petroleum base, rust and oxidation inhibited (R&O) gear oil.

Capacity: 40' to 70' Units, approx. 48 oz. (1.42 l)
80' to 100' Units, approx. 128 oz. (3.78 l)

Oil Change Intervals:

Initial change after **2 weeks** (if desired, this oil may be filtered and reused).

Thereafter, every **2500 hours**, or **6 months** (whichever comes first). Oil should be drained, magnetic plug cleaned, and gearbox flushed and refilled with new oil.

For best results, oil should be drained with conveyor in full down position.

Under extreme conditions, **1 to 3 months**.

*For temperatures below 40° F (4.4° C), use an 80 weight oil of the same quality as the 90 weight. Extra pressure additives may be of value in severe applications.

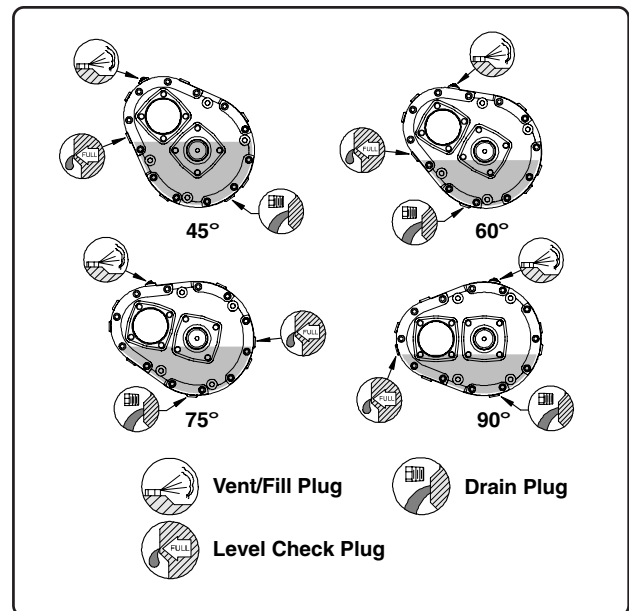

Fig. 19

LUBRICATION & MAINTENANCE

CONVEYOR DRIVE CHAIN TENSION and ADJUSTMENT



WARNING! Whenever you must service or adjust your equipment, make sure to stop the machine and lockout your power source.

Regular inspections should be established in order to ensure the conveyor chain is in good operating condition at all times.

The life of the conveyor chain will be shortened when the chain is allowed to sit in water or is operated in acidic conditions, try to avoid these situations.

To extend chain life, spray a light coat of soybean oil on the chain after each seasons use. **Use extreme caution, keep away from moving chain and paddles.**

Check Chain Tension

1. Inspect conveyor chain for loose bolts, missing chain parts, missing or damaged chain paddles and overall chain condition.
2. Check chain tension. Grasp one of the paddles at the inlet end, and attempt to rotate it up towards the chain (See Fig. 20). Proper chain tension should allow only minimal movement of the paddle.

There may be some flexing of the paddle itself, but overall there should be very minimal movement of the paddle and chain.

Adjust Chain Tension

1. Loosen the four (4) carriage bolts on each of the take-up slides on the head section located at the discharge end of unit, See Fig. 20 (there will be a total of eight carriage bolts).
2. Move the jam nuts on the conveyor chain adjustment bolts in direction desired to either loosen or tighten the chain. **Move the jam nuts in equal increments so that the head shaft remains straight.** Check each side for equal distance by measuring from the shaft of each bearing to the head end. Once proper tension has been set, tighten the eight carriage bolts and secure the jam nuts. If the chain is still too loose after these adjustments, it may be necessary to remove one or more chain links from the chain.

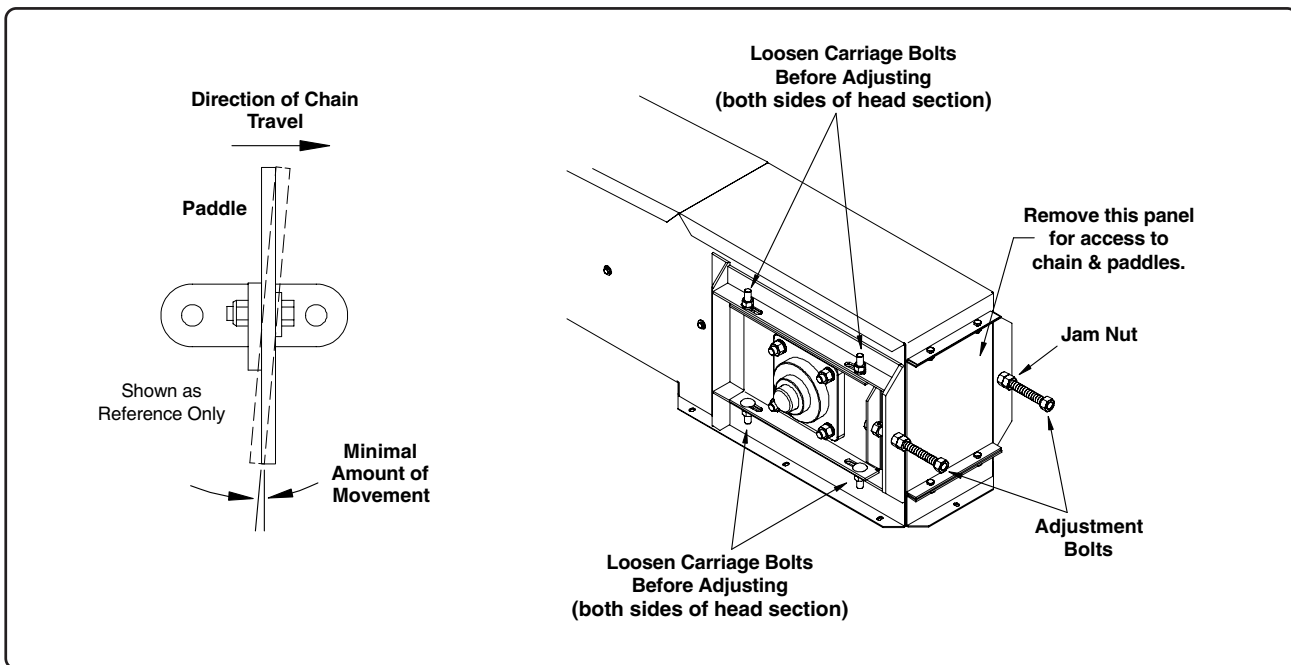

Fig. 20

PTO DRIVELINE LUBRICATION



WARNING! Before engaging PTO, be sure the PTO driveline shaft shield turns freely on shaft.

Keep hands and clothing away from the PTO components during operation.

The PTO driveline has three (3) fittings that require lubrication (See illustration below).

Lubricate all fittings with a good quality lithium based E.P. grease which meets the NLGI #2 Specifications and contains no more than 1% molybdenum disulfide (example: Shell Super Duty or equivalent).

An E.P. grease meeting the NLGI #2 Specifications and containing 3% molybdenum disulfide **may be substituted in the telescoping members only** (example: Mobil Oil Co. - "Mobil Grease CMP," Shell Oil Co. - "Retinax AM," and Texaco - "Molyex EP #0 & #2).

Telescoping members should be lubricated while in the collapsed position.

- The first lube interval should be **16 to 24 hours after initial start-up and operation, then follow the recommendations shown below.**
- Check the u-joint setscrews at the conveyor end to make sure they are tight against the conveyor drive shaft.

Replacement Parts are Not Lubricated

Replacement parts must be lubricated at the time of assembly. Depending on the replacement part, use the chart below to determine the proper amount of grease to use for that particular location.

After repaired parts have been lubricated and installed, follow the recommendations in the chart for correct lubrication intervals.

PTO DRIVELINE SHEAR BOLT

The PTO driveline is equipped with a shear bolt at the tractor connection. Extra shear bolts are provided and stored in the operator's manual container.

The shear bolt protects the conveyor from damage should the conveyor become plugged or subjected to high loads. If this scenario should occur, the shear bolt would "shear off" causing the connection to the conveyor to suddenly stop (the tractor's PTO would still continue turning, but not the conveyor driveline).

Immediately shut down the tractor and lockout before attempting to investigate the cause of the problem.

It is important that the correct replacement bolt be of the same size and strength as the original (see chart below). This is to insure the shear device will function properly to help protect the operator and the conveyor.

PTO Driveline Lubrication Recommendations

After the first lube interval (first 16 to 24 hours of operation) the following schedule should be maintained.

Interval	Location	Amount
4 hrs.	U-Joint Cross & Bearing	1 Pump
8 hrs.	Telescoping Members	4-8 Pumps

Shear Bolt Specifications

Conveyor Size	Shear Bolt Size	Shear Bolt Grade	Replacement Shear Bolt Kit
M50	3/8-16 x 1"	Grade 8	Part No. 1018892

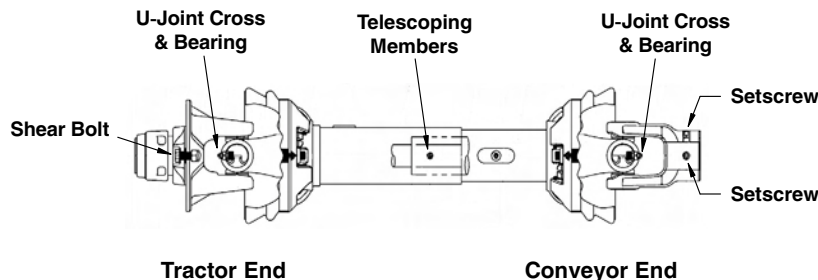

Fig. 21

TROUBLE SHOOTING

TROUBLE SHOOTING

LOW CAPACITY

- The conveyor may not be getting enough grain. Check to see that the hopper intake has not bridged over restricting the flow.
- Chain speed is too slow.
- Grain is high in moisture. A low capacity will likely be achieved with high moisture grain. Excessive feeding of high moisture grain can cause plugging.

PADDLE BREAKING OR BENDING

- Paddles may be coming loose from the chain. Keep the paddles securely connected to the chain.
- Housing misalignment.
- Frequent starts under load. Allow conveyor to clean out before shutting down.
- Sprockets at intake or discharge ends may be off center. Align in center of housing.
- Overfeeding; adjust the feeding of the conveyor to allow less grain to enter while maintaining full speed.

EXCESSIVE CONVEYOR NOISE

- Conveyor chain is too loose. Check chain tension and adjust if necessary (See Maintenance Section).
- Improper assembly or misalignment of housing. Loosen housing connection(s) that are the source of noise and disassemble. Check for end smoothness and grind if necessary.
- Sprockets at intake or discharge end may be off center. Check setscrew in sprocket and ensure that it is tight.

BELT SLIPPAGE

- Incorrect belt tension. Turn the adjustment bolts on the motor mount end until proper tension is reached.
- Unit is plugged. Clean the grain and any obstructions from the conveyor.

TRUNK HOUSING LAYOUT



WARNING! Do Not rely solely on hydraulic or mechanical jacks or the hoist for support. Always use jack stands or equivalent for support.



Keep hands, legs and other body parts out from under the conveyor when conveyor is being raised by the hoist or by any other means.



Some parts are heavy, use assistance with lifting and while assembling these parts.



Wear the proper personal protective gear (ie. safety glasses, ear protection, gloves, etc.).

Keep the assembly and work area clean and free of tools and objects which could cause unsafe situations.

Electric motors and controls shall be installed by a qualified electrician and must meet the standards set by the National Electrical Code and all local and state codes.

Whenever reference is made to the left, right, front or rear of the conveyor, it is always determined by standing at the hitch (inlet) end looking towards the discharge end.

Choose an open level ground accessible to a chain hoist or other lifting devices where the conveyor may be laid out in full length.

It will be convenient for assembly if the sections are placed on stands or saw horses, this will also make assembly of the undercarriage easier as well.

Be sure the stands or saw horses can support the weight of the tube sections. A stand height of 36" tall is recommended.

Before beginning assembly it is suggested to read through the assembly instructions in this manual and layout all items from the kits to ensure all parts are accounted for.

This not only helps you become familiar with the parts and assembly procedures, but also makes you aware of what tools, equipment or materials you may need to complete the assembly process.

1. Position the trunk sections in their respective positions as shown in the following illustrations.

The support stands may have to be repositioned when installing the tracks on the bottom side of the housing. The trunk sections, once connected together, can also be turned upside down to install the tracks and other components that attach to the underside of the conveyor.

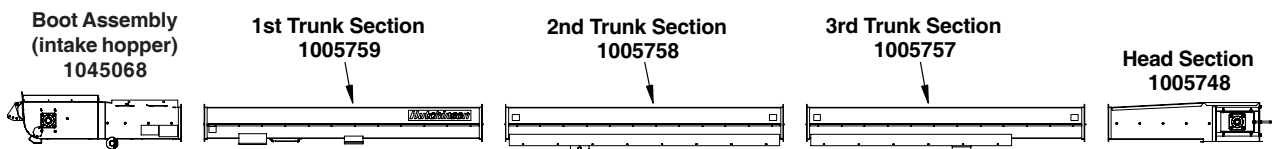

40' Models

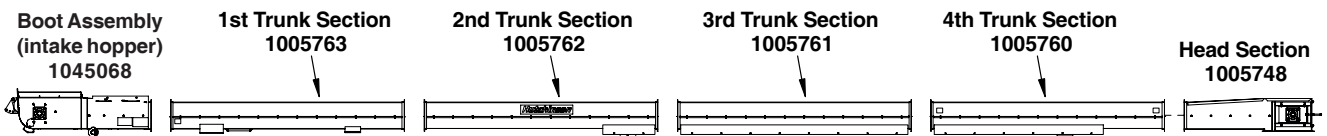

50' Models

ASSEMBLY PROCEDURES

TRUNK HOUSING LAYOUT (con't.)

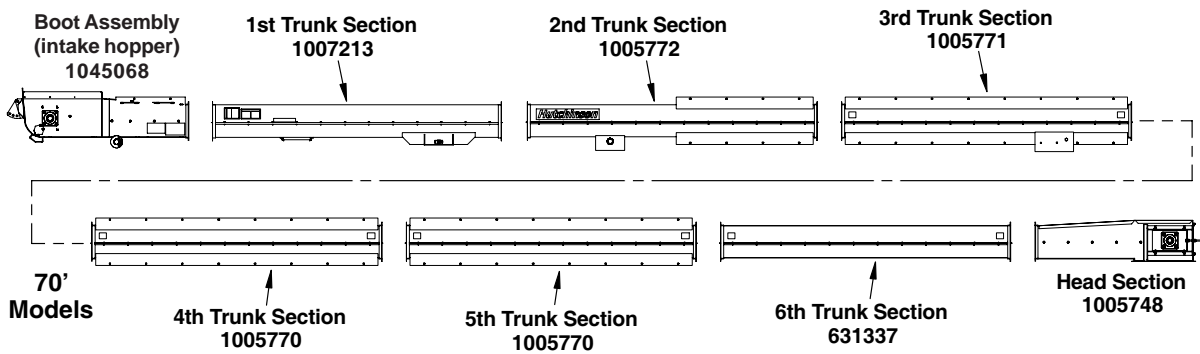
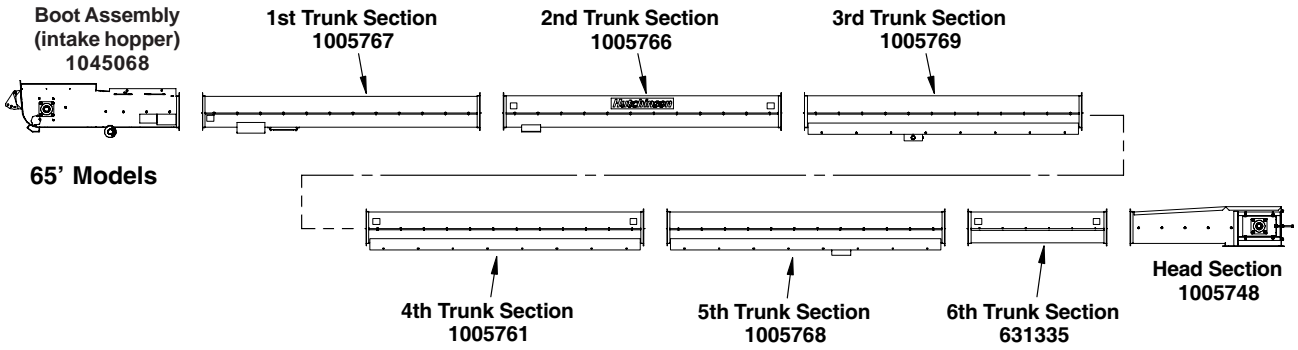
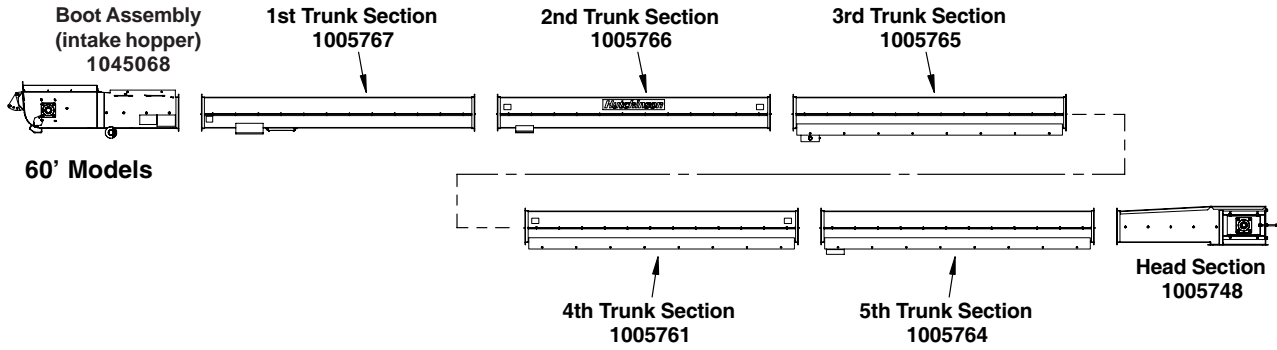

ASSEMBLY PROCEDURES

TRUNK HOUSING LAYOUT (con't.)

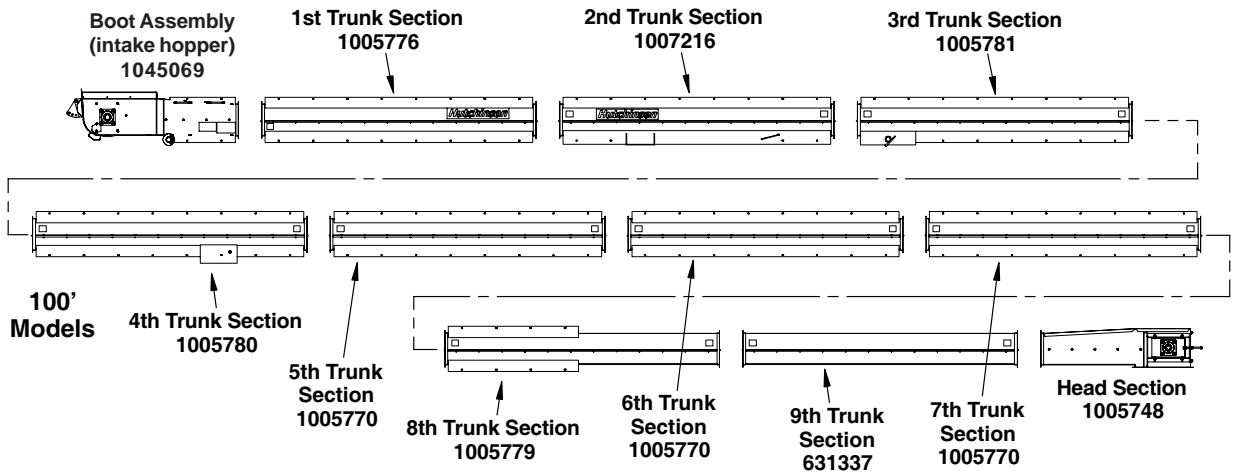
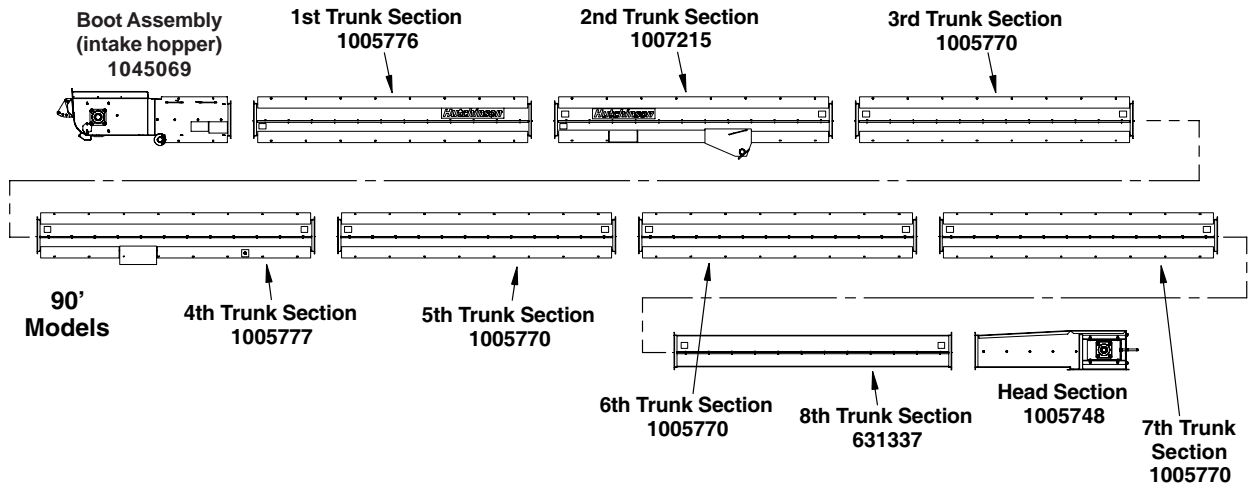
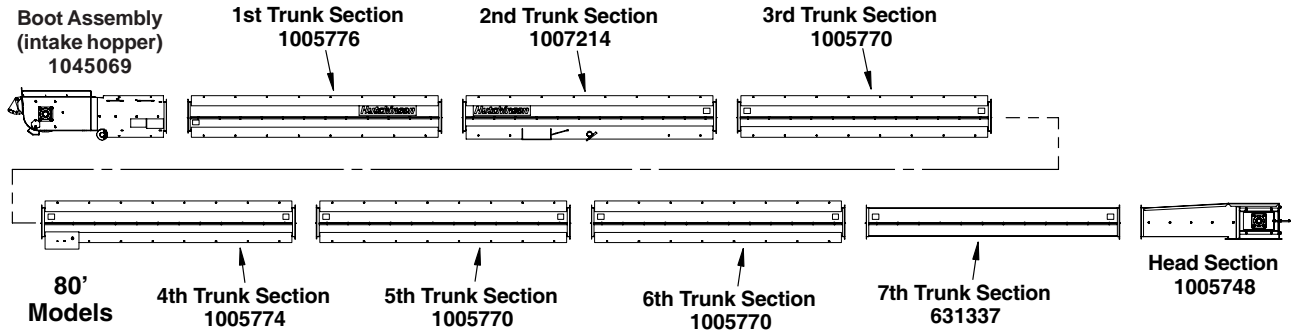

ASSEMBLY PROCEDURES

TRUNK SECTION ASSEMBLY

1. Note the center partition in each of the trunk housings. During assembly the center partition in the next trunk to be installed will overlap on the top of the previous trunk section (See illustration below).
Secure the trunk sections using 3/8" x 1" bolts, lock washers and non-lock nuts in all mounting holes.

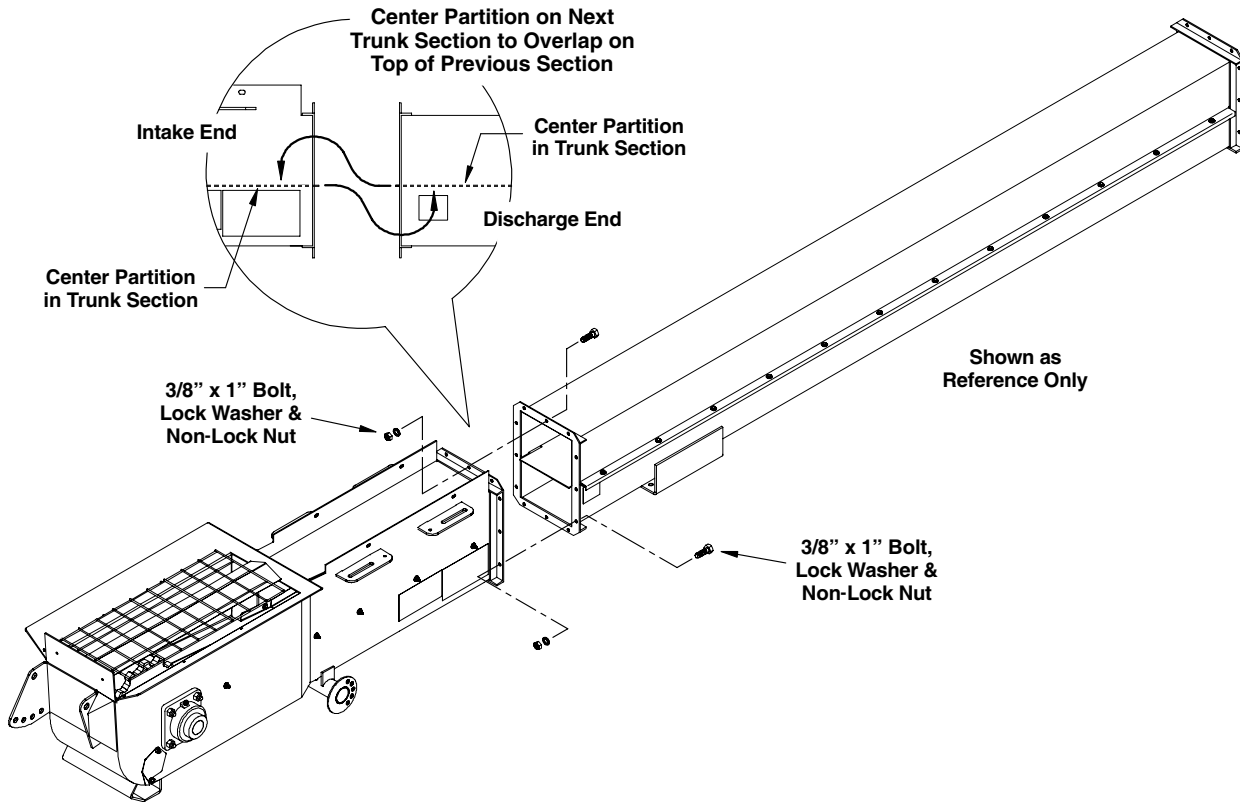

INSTALL TRACK

1. Install track sections as shown in each of the following illustrations.

All track sections will use 3/8" x 1" bolts, flat washers, lock washers and non-lock nuts for mounting to the conveyor. Lay out the track sections in their respective order before beginning to install them onto the conveyor.

The tracks for the 40', 50', 60' and 65' Models (Pages 33 to 35) are attached to the outside of the trunking. The tracks for the 70', 80' 90' and 100' Models (Pages 35 to 39) are attached to the inside of the trunking.

Some models use track sections that are the same part number for the left and right sides of the conveyor. Simply rotate one of the tracks end-for-end for use on the opposite side of the conveyor.

NOTE: Whenever reference is made to the left, right, front and rear of the conveyor, it is always determined by standing at the inlet end, looking towards the discharge end.

40', 50', 60' & 65' Models

Attach Tracks to the Outside of the Trunking Using
3/8" x 1" Bolts, Flat Washers, Lock Washers
and Non-Lock Nuts
(bolt head & flat washer to the outside, flat washer,
lock washer & nut to the inside)

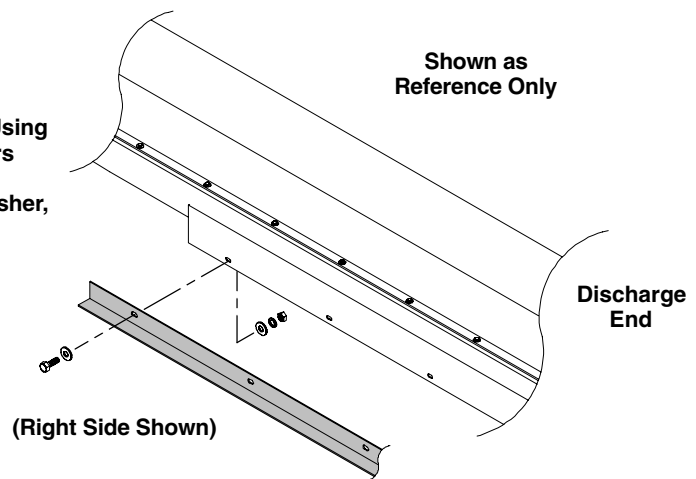

40' Model

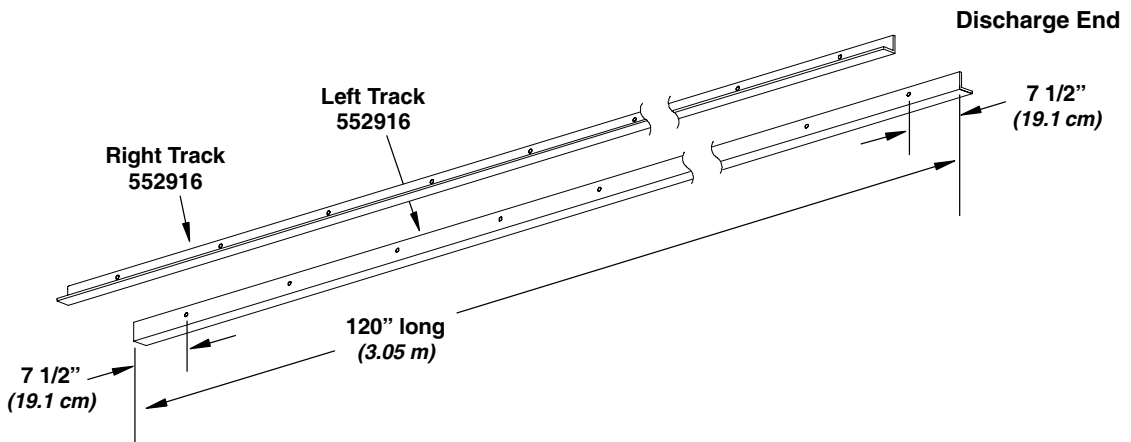
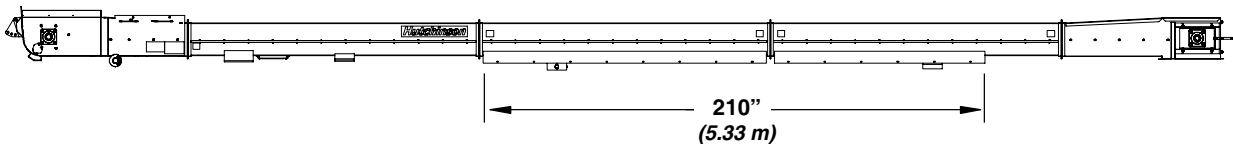

ASSEMBLY PROCEDURES

INSTALL TRACK (con't.)

50' Model

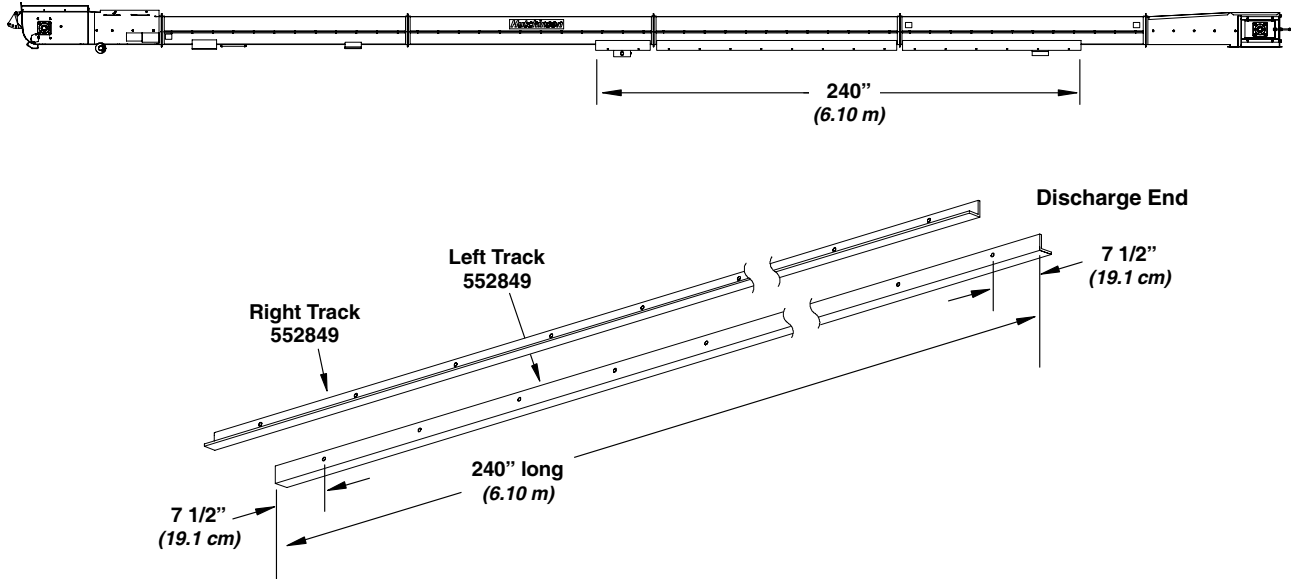

60' Model

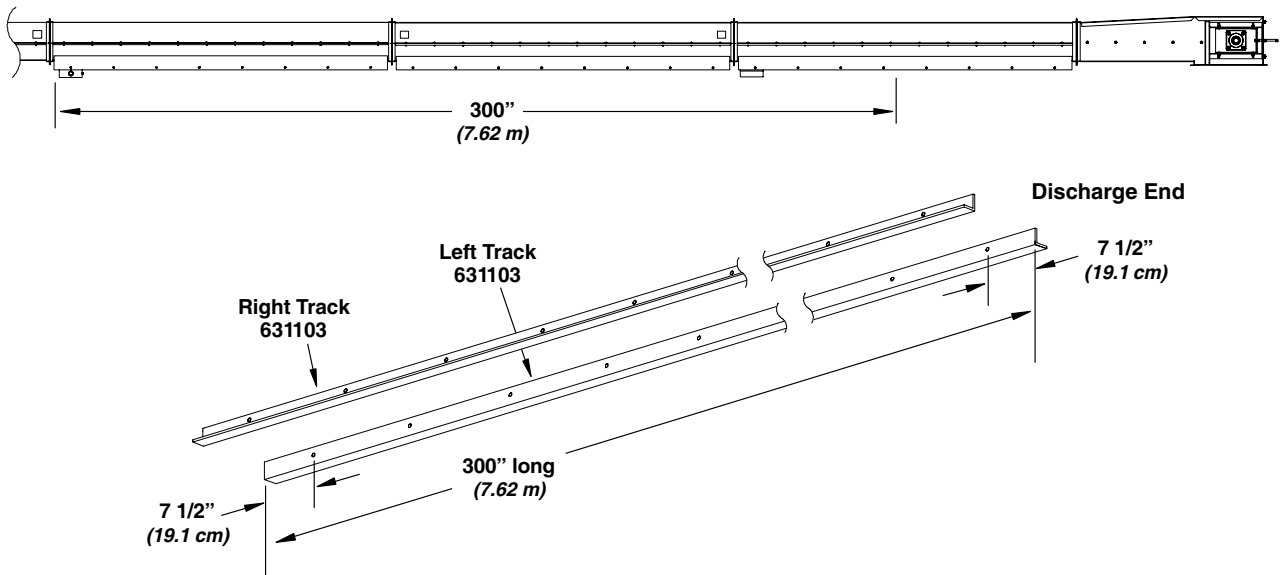

INSTALL TRACK (con't.)

65' Model

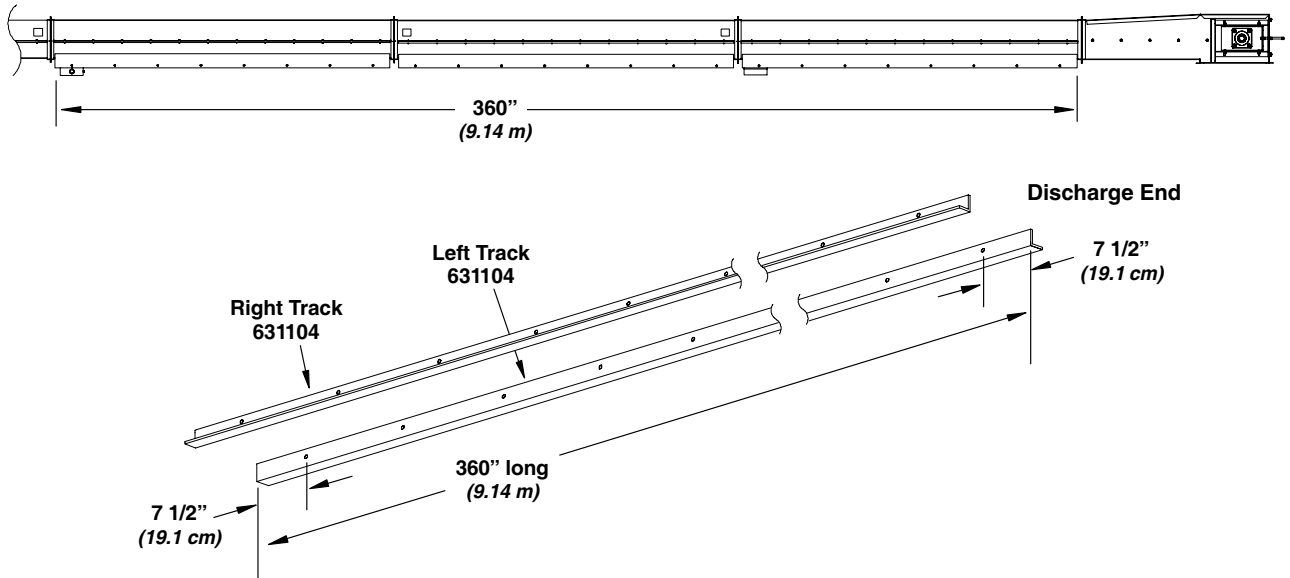

The 70' Models have the tracks installed on the inside of the trunking as shown below. Note the attaching hardware orientation. The bolt head and flat washer to the outside and the flat washer, lock washer and non-lock nut on the inside. See Page 36 for track mounting location and track lengths.

70' Model

Attach Tracks to the Inside of the Trunking Using 3/8" x 1" Bolts, Flat Washers, Lock Washers and Non-Lock Nuts (bolt head & flat washer to the outside, flat washer, lock washer & nut to the inside)

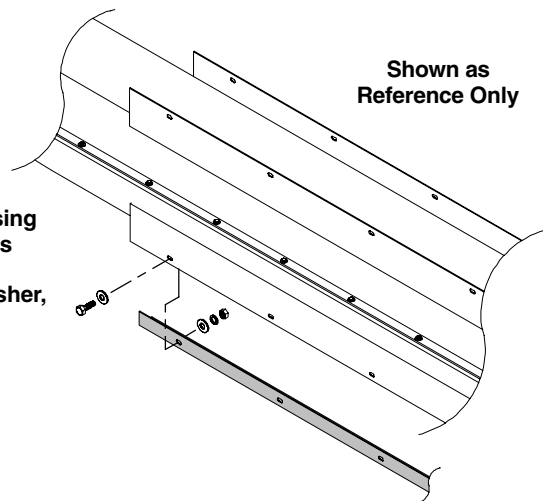

ASSEMBLY PROCEDURES

INSTALL TRACK (con't.)

70' Model

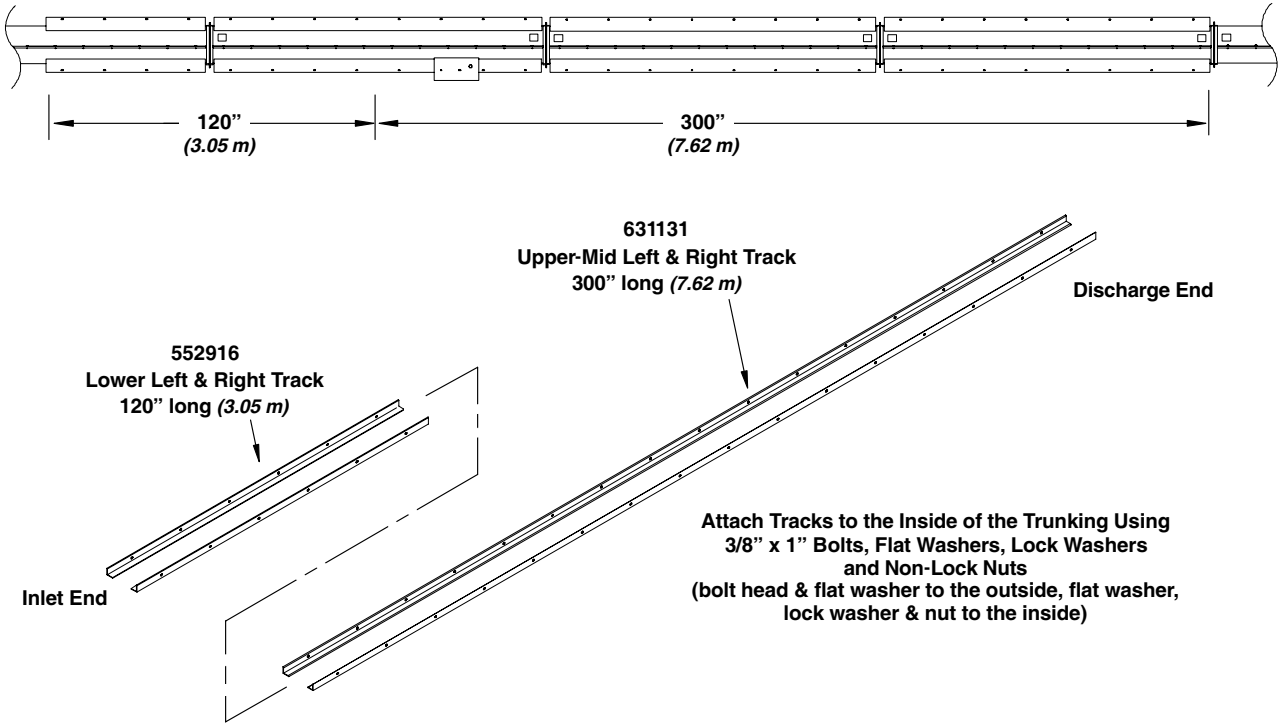

The 80', 90' and 100' Models have the tracks installed on the inside of the trunking as shown in the following illustrations. Note the attaching hardware orientation. The bolt head and flat washer to the inside and the flat washer, lock washer and non-lock nut on the outside. See Pages 37, 38 & 39 for track mounting locations and track lengths.

80', 90' and 100' Models

Attach Tracks to the Inside of the Trunking Using 3/8" x 1" Bolts, Flat Washers, Lock Washers and Non-Lock Nuts (bolt head & flat washer to the inside, flat washer, lock washer & nut to the outside)

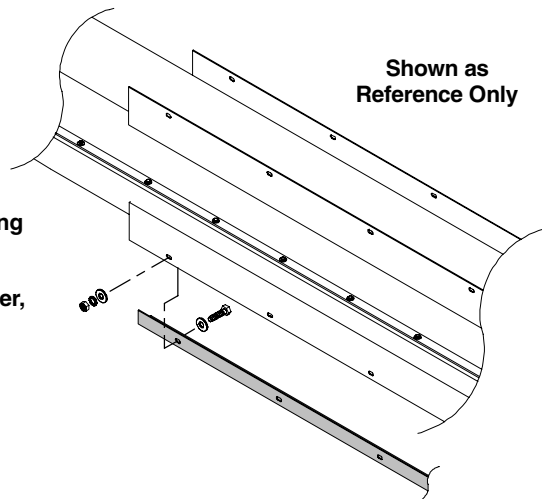

ASSEMBLY PROCEDURES

INSTALL TRACK (con't.)

80'
Models

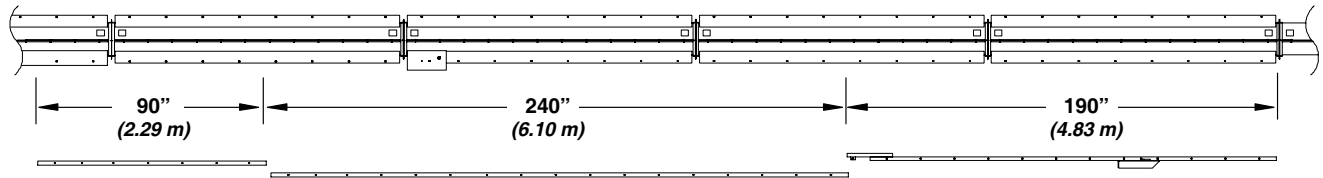

Attach Tracks to the Inside of the Trunking Using
3/8" x 1" Bolts, Flat Washers, Lock Washers
and Non-Lock Nuts
(bolt head & flat washer to the inside, flat washer,
lock washer & nut to the outside)

552754
Lower Left & Right Track
90" long (2.29 m)

Inlet End

552711
Upper-Mid Left & Right Track
240" long (6.10 m)

Discharge
End

130116
Upper Track Weldment
190" long (4.83 m)

3/8" x 1 1/4" Bolt, Flat Washer,
Lock Washer & Non-Lock Nut

ASSEMBLY PROCEDURES

INSTALL TRACK (con't.)

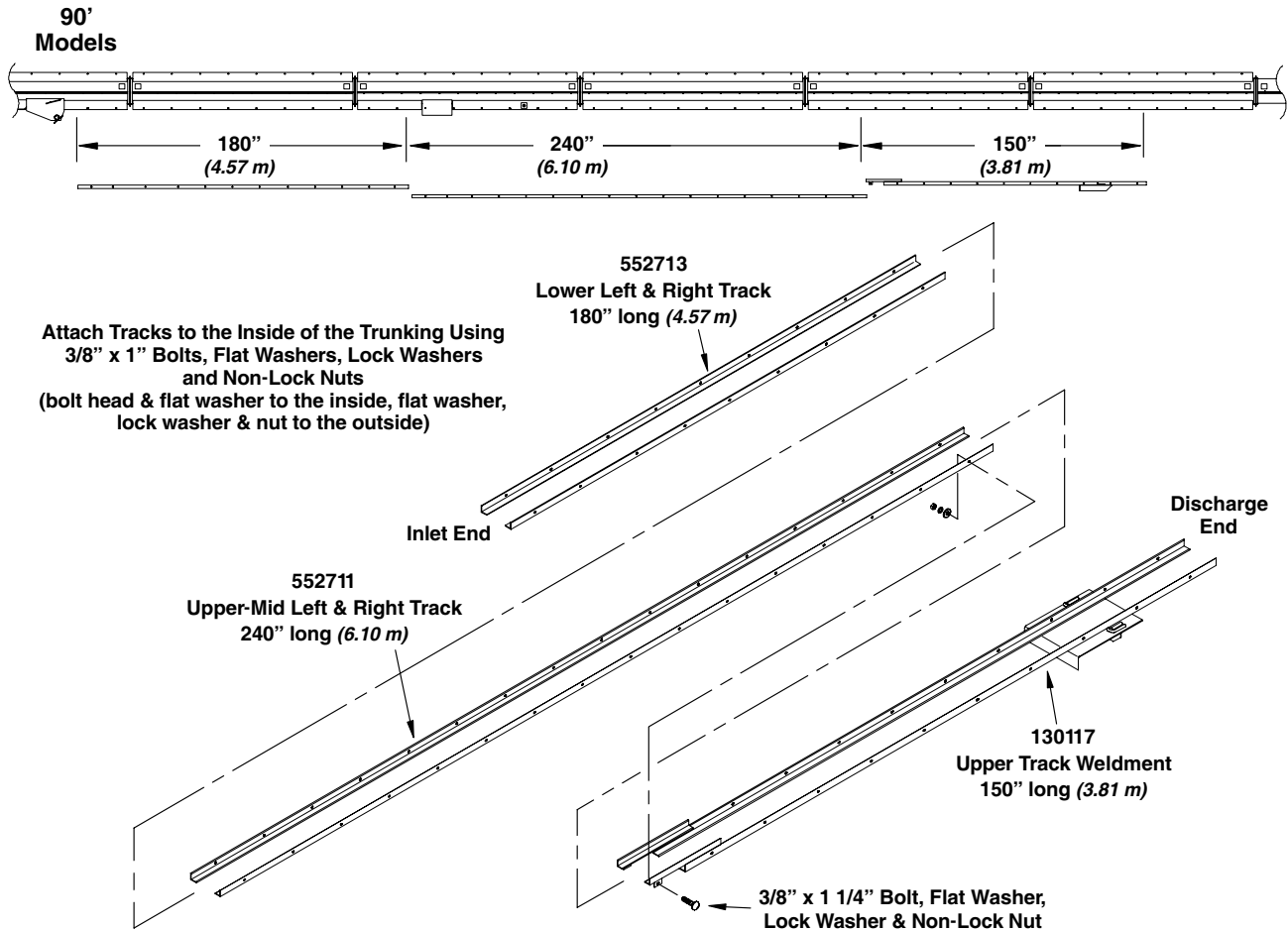

ASSEMBLY PROCEDURES

INSTALL TRACK (con't.)

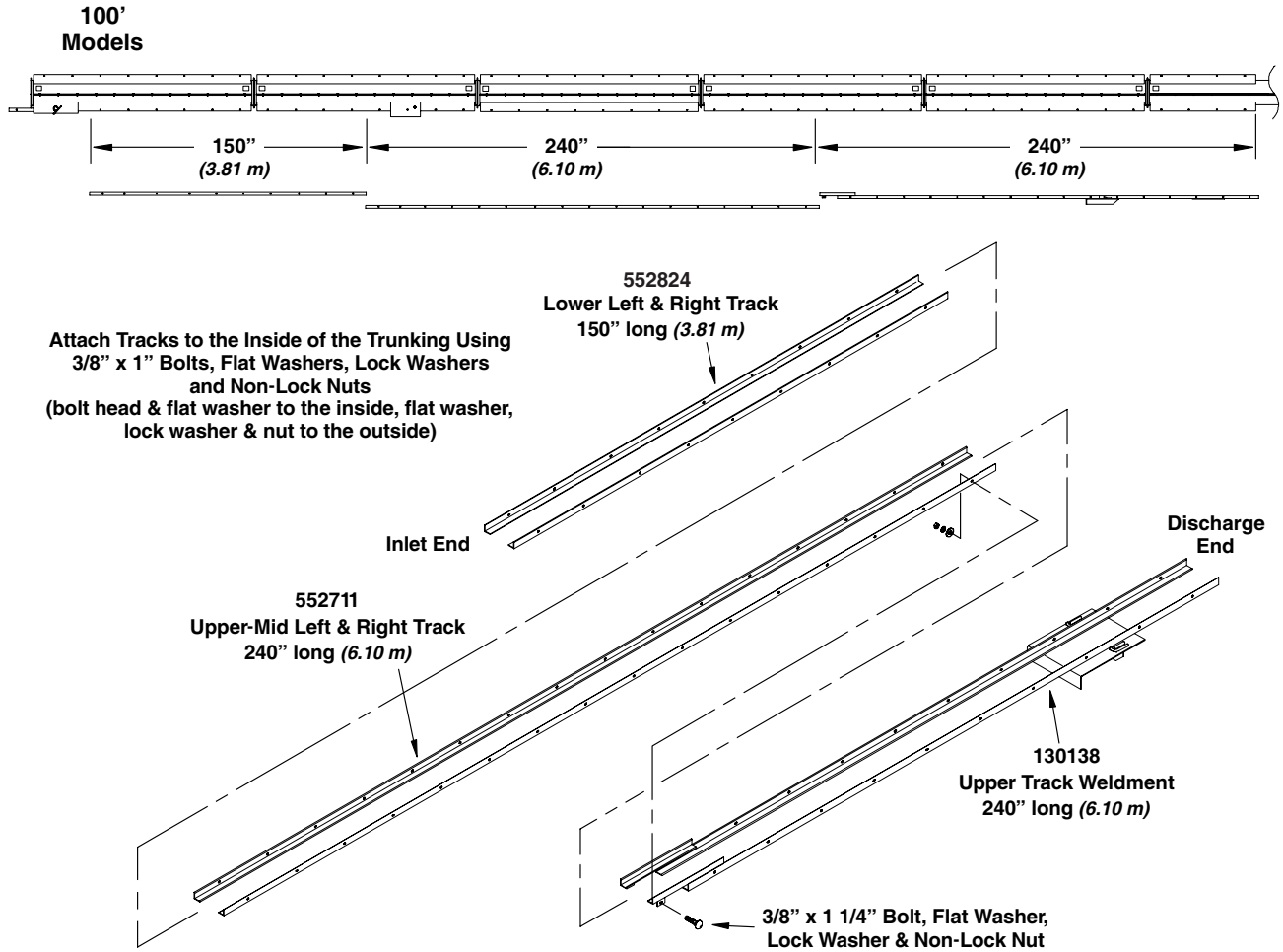

ASSEMBLY PROCEDURES

INSTALL CHAIN & PADDLES

The chain and paddles can now be assembled and installed into the conveyor housing. If desired, the paddles can be attached to the chain before installing the chain into the housing.

IMPORTANT! Do Not overtighten the bolts when attaching the paddles to the chain. Excessive tightening can deform the paddles.

The recommended torque for the paddle bolts and hardware is 15 to 20 ft. lbs. (20.1 to 26.8 N-m).

Install the chain so the paddle mounting bracket will be behind the paddles as the grain is moved up the conveyor housing (See Fig's. 22 & 23).

IMPORTANT! Be careful not to twist the chain when feeding it through the conveyor housing.

To check for twisted chain, place a light source at the inlet section and look into the conveyor housing from the discharge end.

1. Assemble the sections of chain together using the connecting links and cotter pins provided.

Note: The chain supplied with the unit is more than sufficient in length for proper installation. It will be necessary to cut the chain to the appropriate length during installation, if not, there will be too much slack in the chain even when all adjustment procedures have been done.

2. Fasten the paddles to the attachment brackets welded to the chain (See Fig 22). Secure paddles using four (2) 5/16" x 1 1/4" bolts, (2) flat washers and (2) nylon locknuts (bolts & flat washers on paddle side).
3. The chain and paddles will be inserted into the bottom partition of the housing from the discharge end of the conveyor (make sure the paddles are facing the discharge end).
4. Remove the access panel from the front of the head section (See Fig. 24 on Page 41). Route the chain and paddles down the bottom partition in the housing to the inlet hopper, around the hopper sprocket, and back up through the upper partition to the discharge end.
5. Route the chain around the head sprocket and check chain length. Cut to appropriate length and attach the chain together using connecting link and cotter pins.
6. Adjust the chain tension. Loosen the four carriage bolts on each side of the head section (for a total of eight bolts). Loosen the 5/8" jam nuts on the threaded adjustment bolts. Use the adjustment bolts to achieve chain tension (move the adjustment bolts in equal increments so the head shaft remains square. Check each side for equal distance by measuring from the shaft to the end of the head).

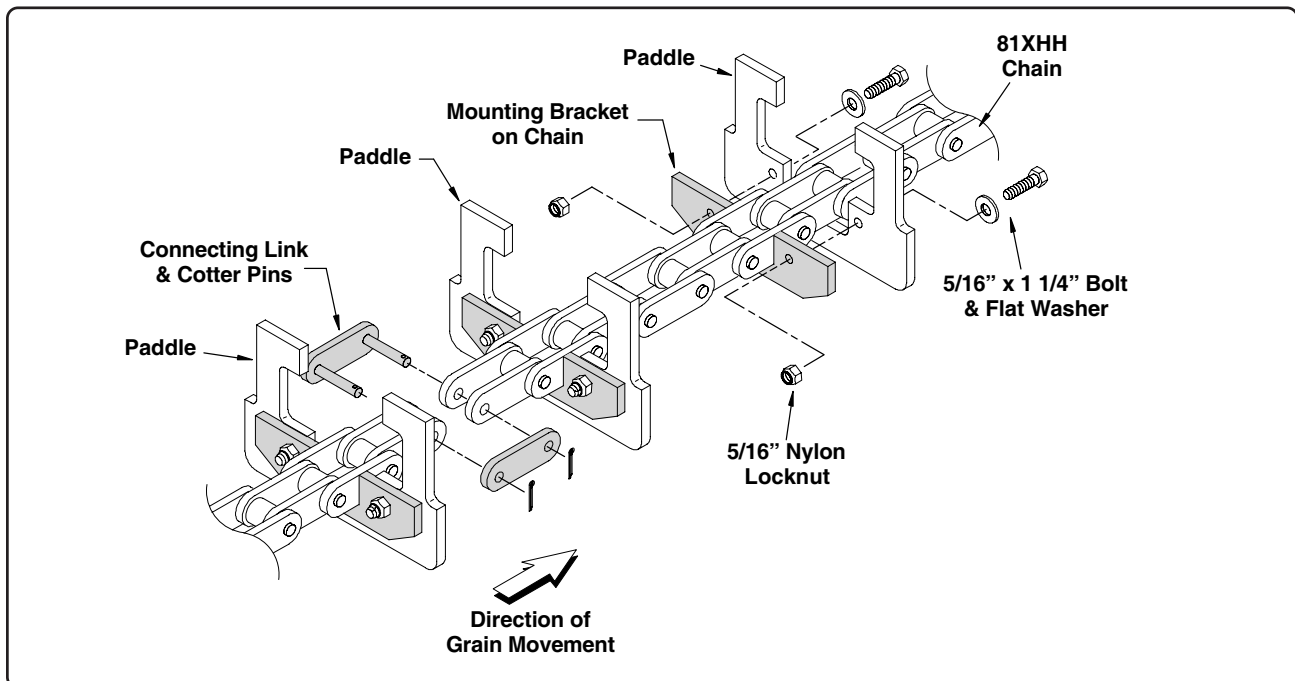

Fig. 22

INSTALL CHAIN & PADDLES (con't.)

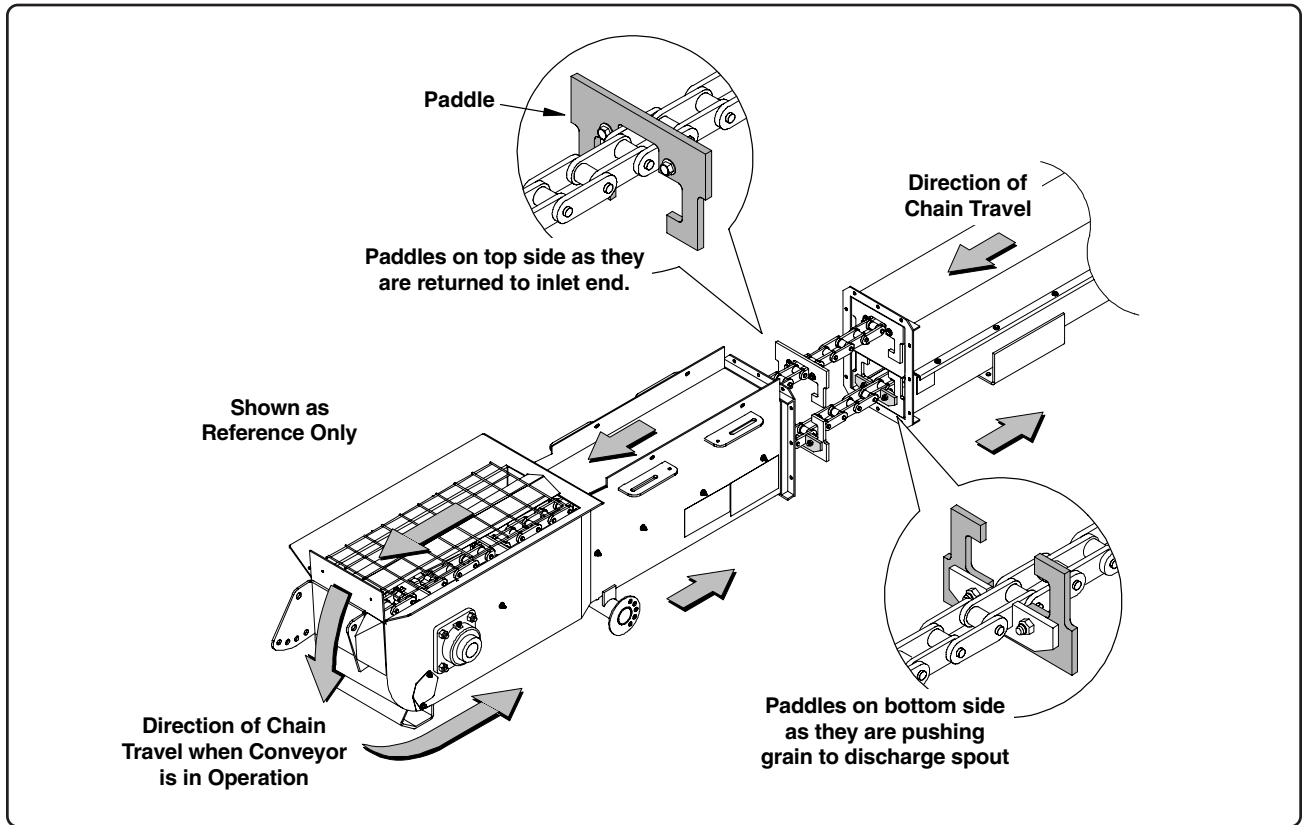

Fig. 23

7. Once proper tension has been set, tighten the eight carriage bolts previously loosened and secure the jam nuts locking the adjustment bolts into place.

To check chain tension, grasp one of the paddles and attempt to rotate it up towards the chain. There should be very minimal movement of the paddle. If the chain is still too loose after adjustments have been made, it may be necessary to remove one or more of the chain links from the chain.

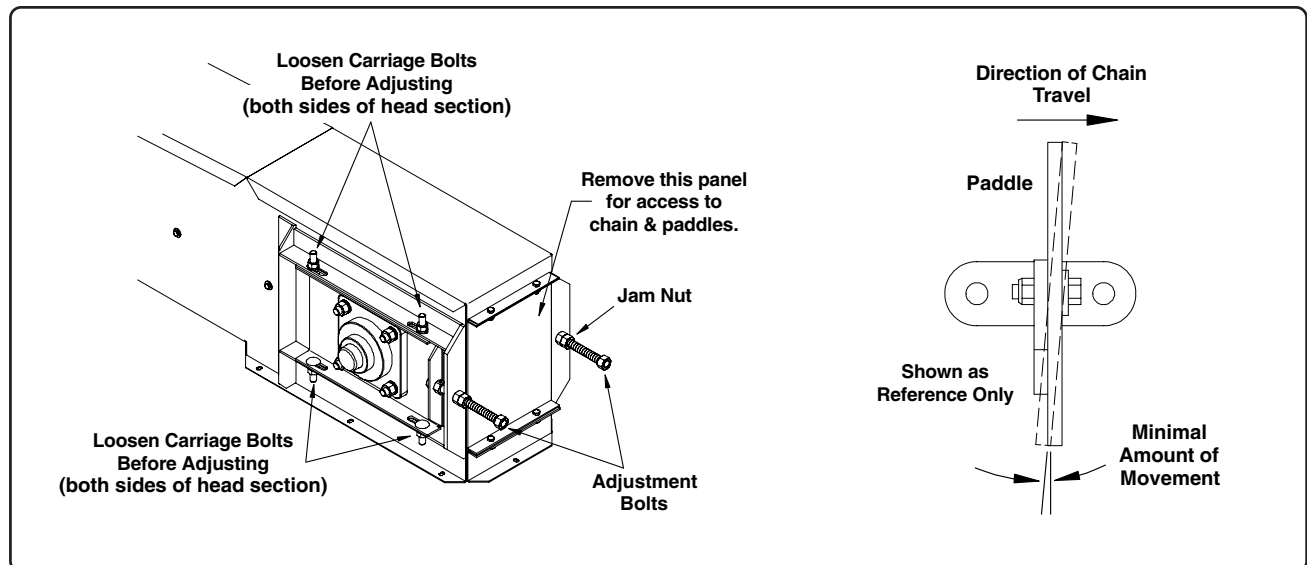

Fig. 24

ASSEMBLY PROCEDURES

INSTALL SPOUT

1. Once the head section and chain and paddles have been installed, the spout can be mounted to the discharge opening.

Secure the spout using nine (9) 5/16" x 3/4" bolts, lock washers and non-lock nuts (See Fig. 25).

NOTE: For operations where the Mass-Mover will be operated at a low angle, the discharge spout can be attached reverse as shown in Fig. 25.

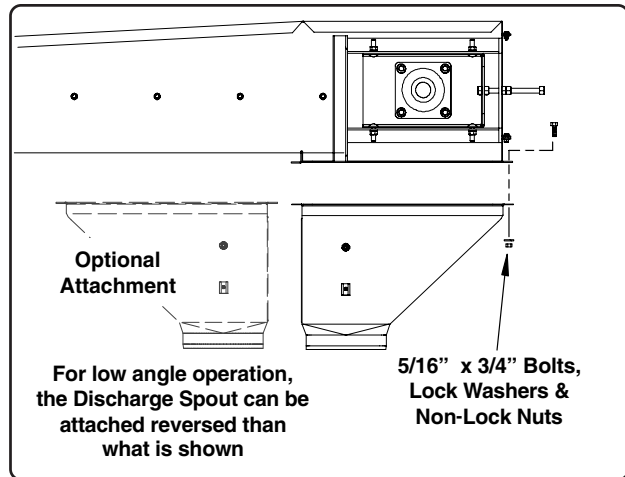
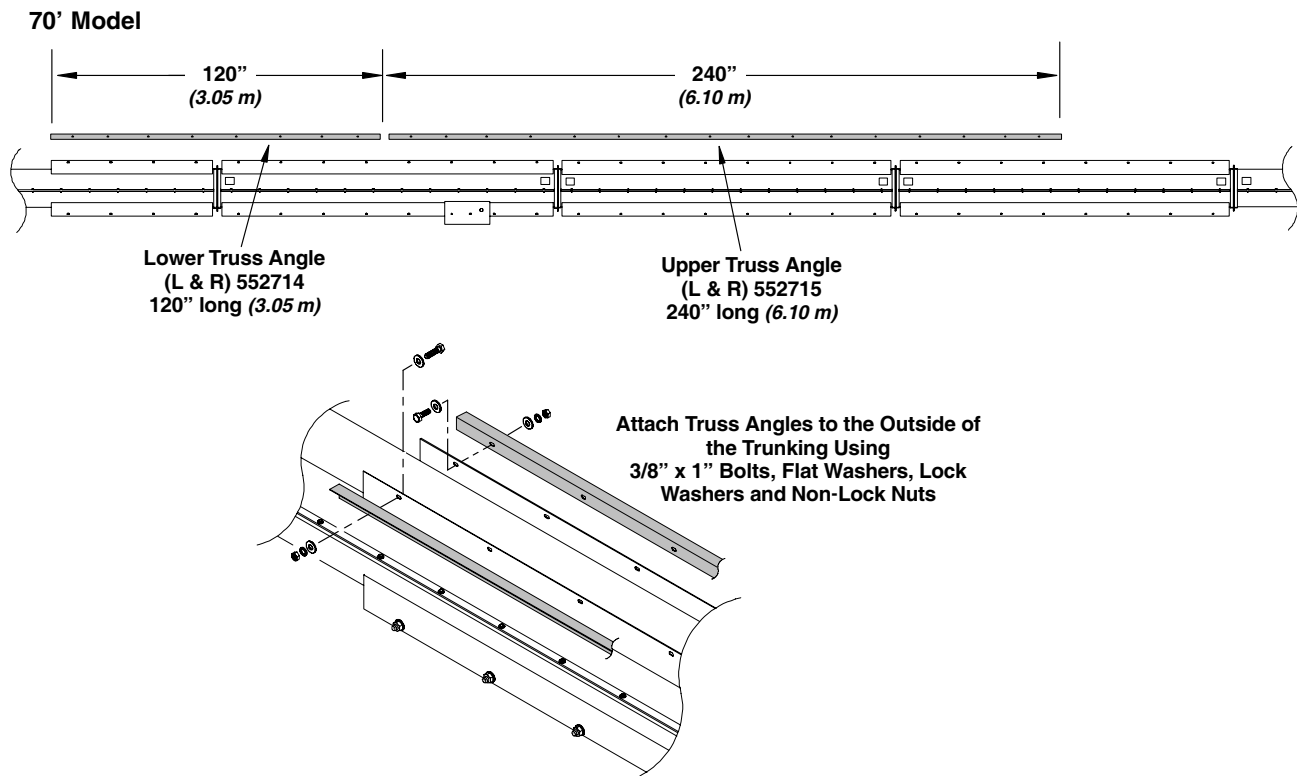

Fig. 25

TRUSS ASSEMBLY, 70' MODELS

The truss angles have the same part number and are designed to fit either the left or right side of the conveyor. Simply rotate one of the angles end-for-end to use on the opposite side of the conveyor.

1. Attach the truss angles to the top side of the trunking. Secure using 3/8" x 1" bolts, flat washers, lock washers and non-lock nuts (the truss angles will be located on the outside of the trunking as shown, the bolt heads will be positioned from the inside of the trunking).



TRUSS ASSEMBLY (con't.)

TRUSS ASSEMBLY, 80' MODELS

The truss angles have the same part number and are designed to fit either the left or right side of the conveyor. Simply rotate one of the angles end-for-end to use on the opposite side of the conveyor.

1. Beginning at the inlet end of the conveyor, layout the truss angles in their respective order as shown. Note the truss angles that will be attached to the bottom side of the trunking. These 180" (4.57 m) truss angles will also be attached to the outside of the trunking.
 2. Attach the truss angles to the top-side of the trunking. Secure using 3/8" x 1" bolts, flat washers, lock washers and non-lock nuts (the truss angles will be located on the outside of the trunking as shown, the bolt heads will be positioned from the inside of the trunking).
- Attach the 180" (4.57 m) truss angle to the bottom side of the trunking and secure using the same hardware used to secure the top-side truss angles.

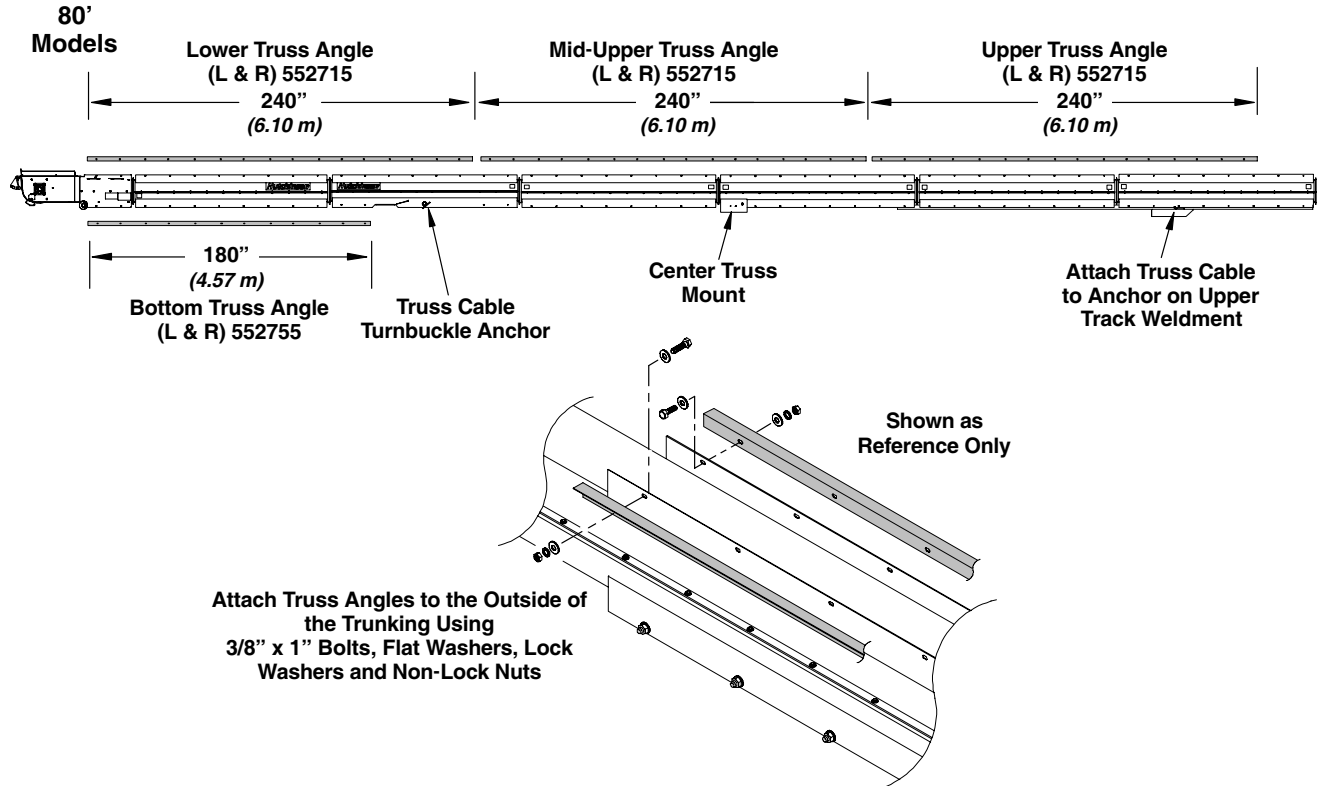

ASSEMBLY PROCEDURES

TRUSS ASSEMBLY, 80' MODELS (con't.)

3. After the truss angles have been attached, install the center truss support. Secure the center truss support to the mount using one (1) 1/2" x 12 1/2" bolt, flat washers, lock washer and non-lock nut (place flat washers on each end of bolt).
4. Attach the turnbuckles to the anchor mounts located near the inlet end of the conveyor (See illustration below). Using the cable thimble and two 3/8" cable clamps attach the 43' (13.11 m) long truss cables to the turnbuckles (make sure the u-bolt portion of the clamp is against the loose end of the cable).
Route the cable over the center truss support and loosely attach the cable to the top of the truss support with the 3/8" cable clamps (the clamp will be secure the cable on the top side of the support with the lock washer and nuts on the bottom side of the support (See illustration below).
Attach the other end of each cable to the cable anchors on each side of the upper track weldment. Pull the cables taut and secure using one cable thimble and two 3/8" cable clamps for each truss cable (make sure the u-bolt portion of the clamp is against the loose end of the cable).
5. Use the turnbuckles to tighten the cables. Once cables are tight and trunking sections are straight, ensure the center truss support is 90 degrees to the trunk section and tighten cable clamps on top of the truss support. Any excess cable length can be cut off if desired.

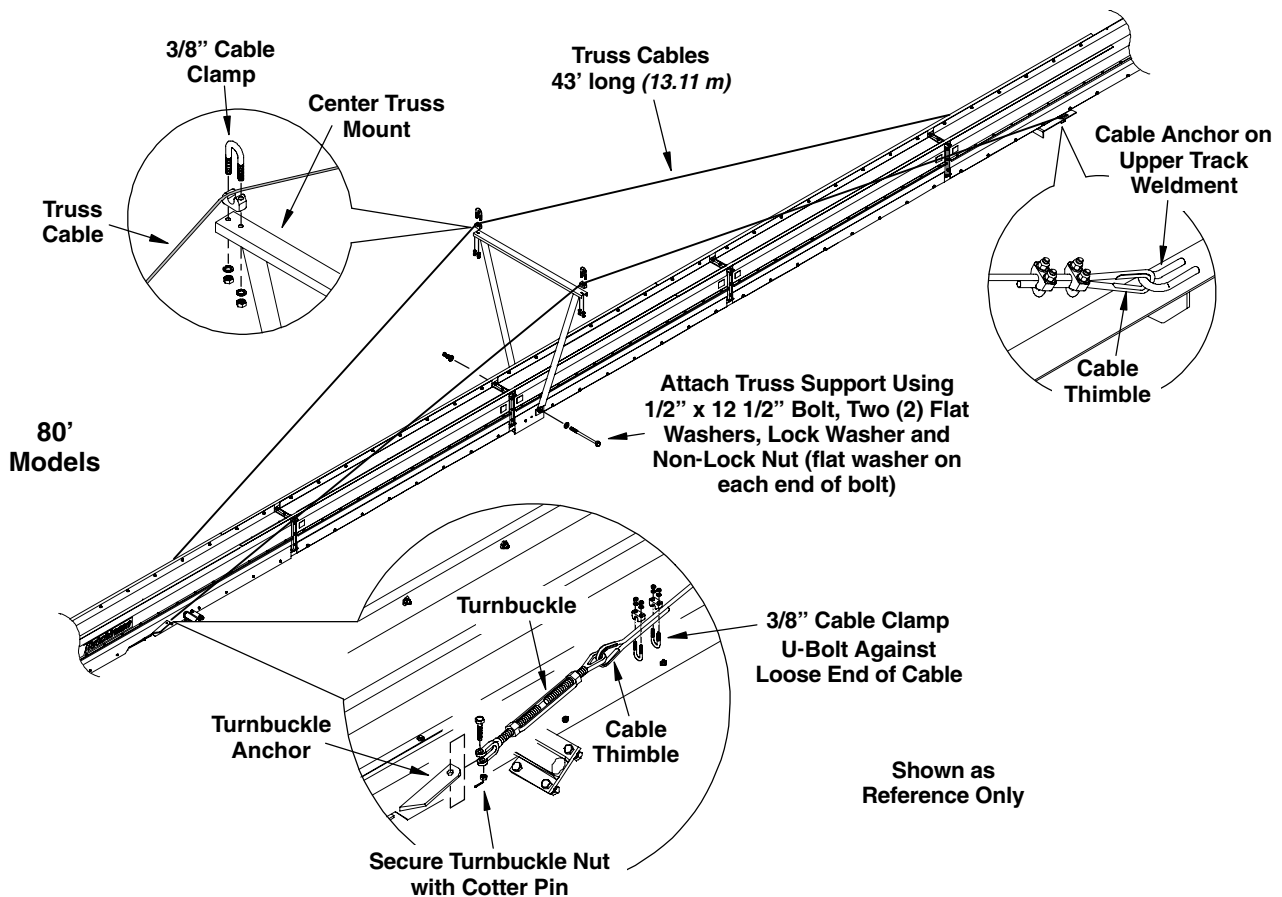

TRUSS ASSEMBLY (con't.)

TRUSS ASSEMBLY, 90' MODELS

The truss angles have the same part number and are designed to fit either the left or right side of the conveyor. Simply rotate one of the angles end-for-end to use on the opposite side of the conveyor. **NOTE: The truss angles on the bottom side of the trunking do have a left and right side, install these accordingly.**

1. Beginning at the inlet end of the conveyor, layout the truss angles in their respective order as shown. Note the truss angles that will be attached to the bottom side of the trunking. These 173 1/4" (4.27 m) truss angles will also be attached to the outside of the trunking.
2. Attach the truss angles to the top-side of the trunking. Secure using 3/8" x 1" bolts, flat washers, lock washers and non-lock nuts (the truss angles will be located on the outside of the trunking as shown, the bolt heads will be positioned from the inside of the trunking).

Attach the 173 1/4" (4.27 m) truss angles to the bottom side of the trunking and secure using the same hardware used to secure the top-side truss angles.

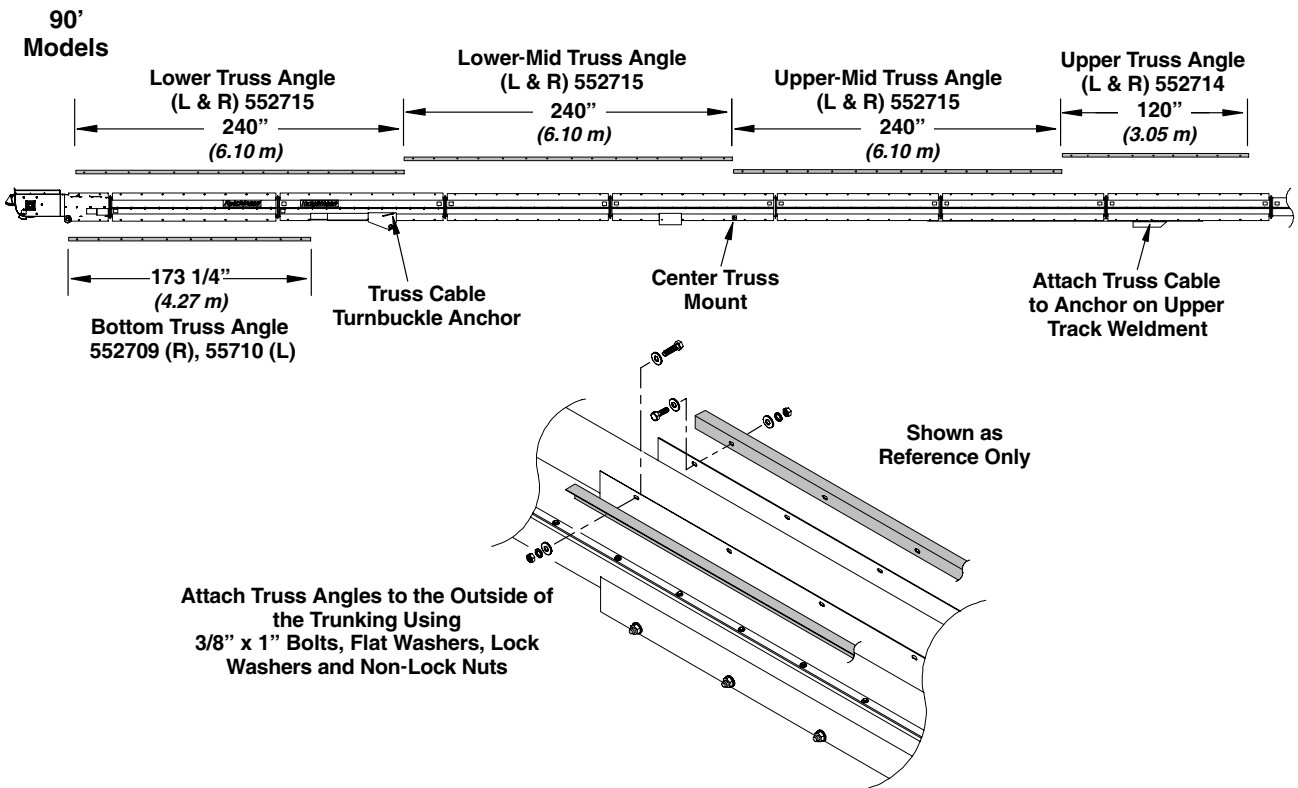

ASSEMBLY PROCEDURES

TRUSS ASSEMBLY, 90' MODELS (con't.)

3. After the truss angles have been attached, install the center truss support. Secure the center truss support to the mount using one (1) 1/2" x 12 1/2" bolt, flat washers, lock washer and non-lock nut (place flat washers on each end of bolt).

4. Attach the turnbuckles to the anchor mounts located near the inlet end of the conveyor (See illustration below). Using the cable thimble and two 3/8" cable clamps attach the 47' (14.33 m) long truss cables to the turnbuckles (make sure the u-bolt portion of the clamp is against the loose end of the cable).

Route the cable over the center truss support and loosely attach the cable to the top of the truss support with the 3/8" cable clamps (the clamp will be secure the cable on the top side of the support with the lock washer and nuts on the bottom side of the support (See illustration below).

Attach the other end of each cable to the cable anchors on each side of the upper track weldment. Pull the cables taut and secure using one cable thimble and two 3/8" cable clamps for each truss cable (make sure the u-bolt portion of the clamp is against the loose end of the cable).

5. Use the turnbuckles to tighten the cables. Once cables are tight and trunking sections are straight, ensure the center truss support is 90 degrees to the trunk section and tighten cable clamps on top of the truss support. Any excess cable length can be cut off if desired.

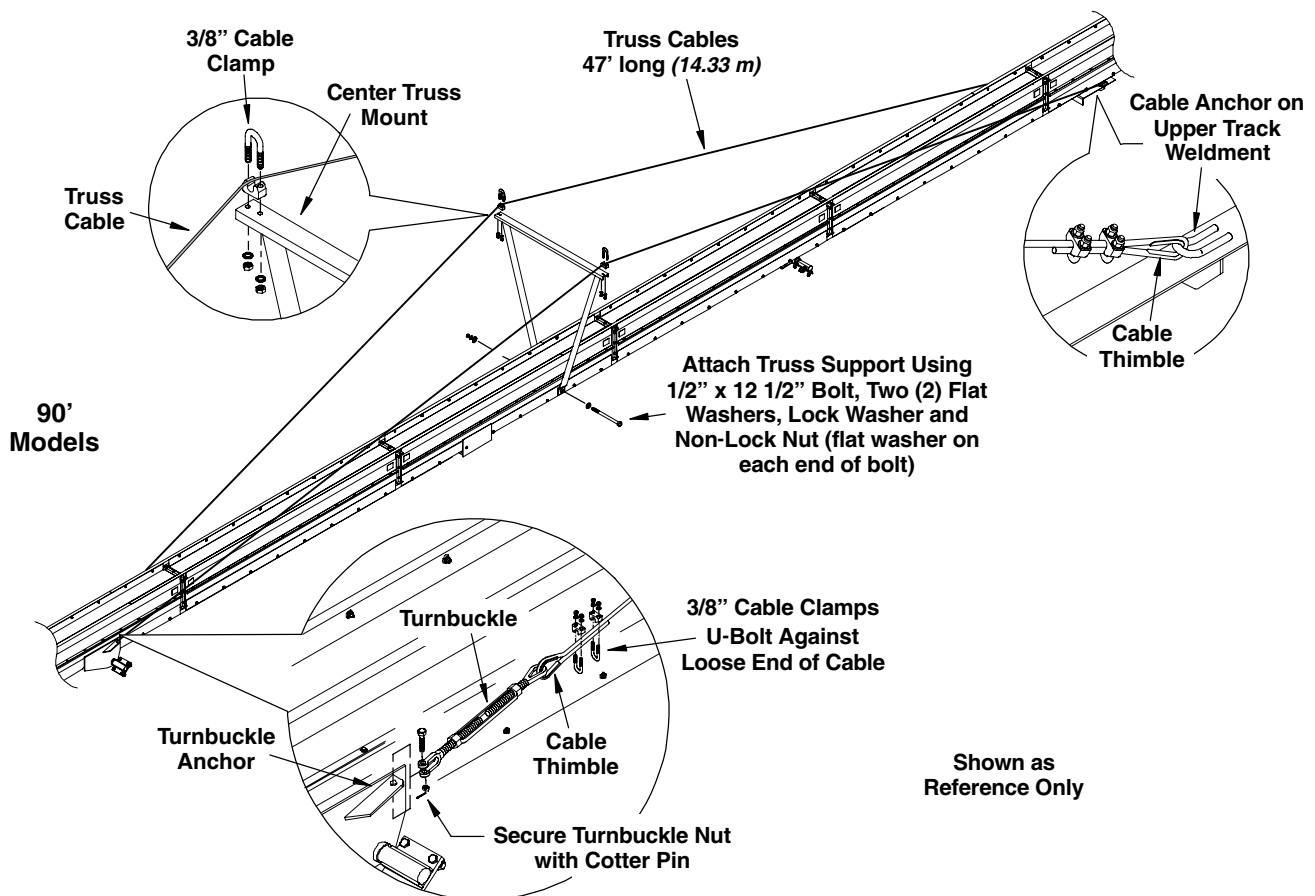

TRUSS ASSEMBLY (con't.)

TRUSS ASSEMBLY, 100' MODELS

The truss angles have the same part number and are designed to fit either the left or right side of the conveyor. Simply rotate one of the angles end-for-end to use on the opposite side of the conveyor.

1. Beginning at the inlet end of the conveyor, layout the truss angles in their respective order as shown. Note the truss angles that will be attached to the bottom side of the trunking. These 180" (4.57 m) truss angles will also be attached to the outside of the trunking.
2. Attach the truss angles to the top-side of the trunking. Secure using 3/8" x 1" bolts, flat washers, lock washers and non-lock nuts (the truss angles will be located on the outside of the trunking as shown, the bolt heads will be positioned from the inside of the trunking).

Attach the 180" (4.57 m) truss angles to the bottom side of the trunking and secure using the same hardware used to secure the top-side truss angles.

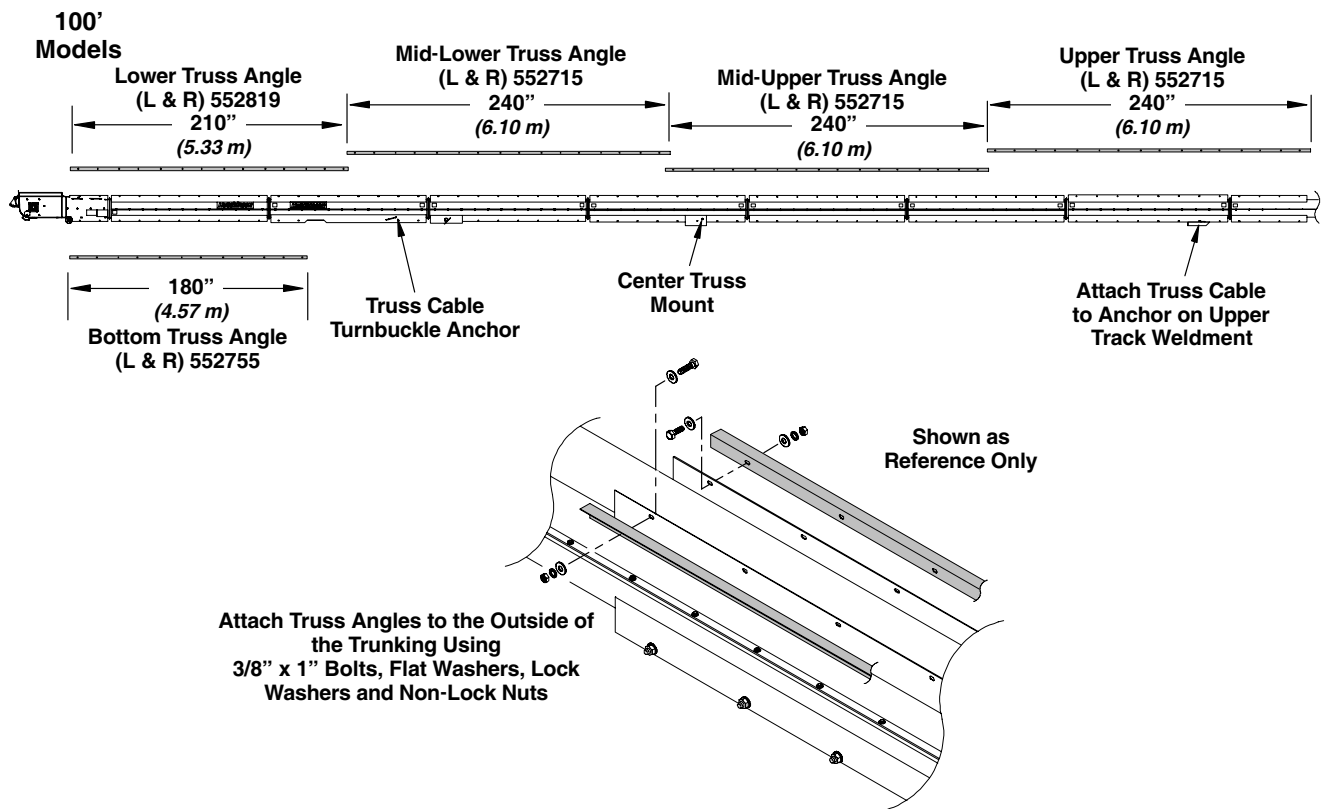

ASSEMBLY PROCEDURES

TRUSS ASSEMBLY, 100' MODELS (con't.)

3. After the truss angles have been attached, install the center truss support. Secure the center truss support to the mount using one (1) 1/2" x 12 1/2" bolt, flat washers, lock washer and non-lock nut (place flat washers on each end of bolt).
4. Attach the turnbuckles to the anchor mounts located near the inlet end of the conveyor (See illustration below). Using the cable thimble and two 3/8" cable clamps attach the 53' (16.15 m) long truss cables to the turnbuckles (make sure the u-bolt portion of the clamp is against the loose end of the cable).
Route the cable over the center truss support and loosely attach the cable to the top of the truss support with the 3/8" cable clamps (the clamp will be secure the cable on the top side of the support with the lock washer and nuts on the bottom side of the support (See illustration below).
Attach the other end of each cable to the cable anchors on each side of the upper track weldment. Pull the cables taut and secure using one cable thimble and two 3/8" cable clamps for each truss cable (make sure the u-bolt portion of the clamp is against the loose end of the cable).
5. Use the turnbuckles to tighten the cables. Once cables are tight and trunking sections are straight, ensure the center truss support is 90 degrees to the trunk section and tighten cable clamps on top of the truss support. Any excess cable length can be cut off if desired.

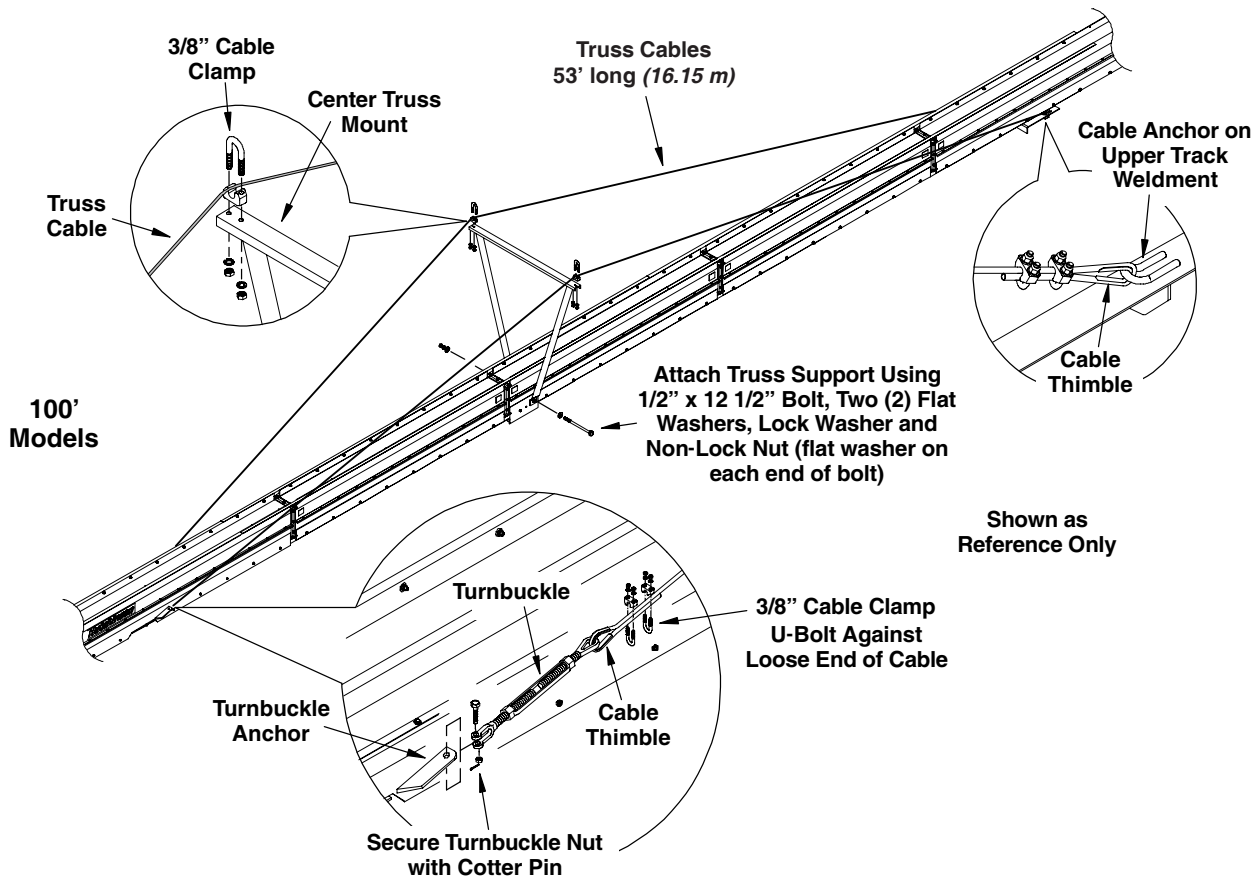

ELECTRIC DRIVE ASSEMBLY **f/ 40', 50', 60', 65' & 70' MODELS**

IMPORTANT! The gearbox is shipped ***without*** oil. **Oil must be added before operating the conveyor.** Refer to Page 25 for proper filling procedures.

1. Bolt the motor mount tightener bracket to the side of the inlet boot as shown below. Secure bracket using two (2) 3/8" x 1 1/4" bolts, flat washers and nylon locknuts.
2. Attach the threaded tightener rod to the bottom of the motor mount plate using two (2) 1/2" x 1 1/2" bolts, flat washers and nylon locknuts.
3. Thread a 3/4" non-lock nut onto the threaded rod and slide on a 3/4" flat washer. Position the motor mount plate onto the mount brackets welded to the conveyor housing while inserting the threaded rod into the adjustment bracket as shown below.
4. Slide another flat washer onto the rod and thread on a 3/4" non-lock nut (thread the nuts on leaving a good portion of the threaded rod exposed to allow for adjustment when the belts are installed).
5. Loosely bolt the motor mount plate to the mount brackets welded to the inlet boot. Secure using four (4) 1/2" x 1 1/4" carriage bolts, flat washers and nylon locknuts (See illustration below).
6. Attach the upper belt guard mount bracket to the rear motor mount bracket as shown below. Secure the bracket in the round mounting hole using one (1) 5/16" x 1" bolt and nylon locknut.

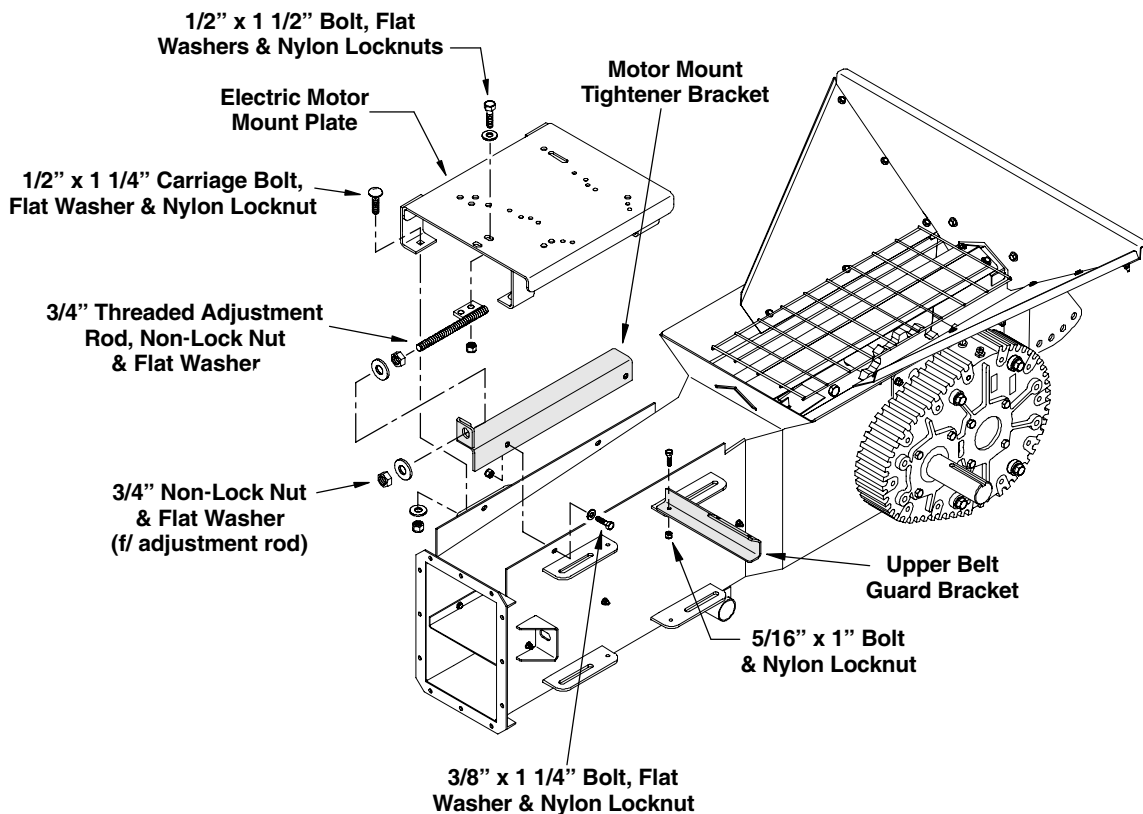

ASSEMBLY PROCEDURES

ELECTRIC DRIVE ASSEMBLY

f/ 40', 50', 60', 65' & 70' MODELS (con't.)

7. Bolt the electric motor to the motor mount plate using the appropriate hardware and hole mount location (**the motor and its mounting hardware are not furnished**).
8. Remove the two 1/2" x 4 1/2" bolts and lock washers that secure the gearbox to the inlet boot (the bolts are located closest to the input shaft).
Install the belt guard as shown. Slide the original lock washers and a 1/2" flat washer onto the two bolts previously removed. Reinstall the bolts to secure the belt guard to the gearbox (do not tighten completely at this time).
9. Secure the upper portion of the belt guard to the upper belt guard bracket that was previously installed onto the rear motor mount bracket. Secure the belt guard using two (2) 5/16" x 1" bolts, four (4) flat washers and two (2) nylon locknuts. Tighten all hardware securing the belt guard.
10. Insert the 3/8" sq. x 2" long key into the keyway on the gearbox input shaft. Install the 15.4" P.D. diameter shaft and bushing onto the input shaft. Position sheave as close to the gearbox as possible without actually contacting the gearbox. Secure sheave to input shaft.
11. Insert a 3/8" sq. x 2" long key into the keyway on the electric motor shaft. Install the 4.2" P.D. sheave and bushing onto the shaft.
12. Align the sheaves by placing a straight edge along the face of each sheave. Verify sheave alignment, make any necessary adjustments and secure sheave to motor shaft.
13. Install the belts over the sheaves, and using the threaded adjustment rod attached to the front of the motor mount plate, tighten the belts until proper tension has been achieved.
Proper belt tension is approximately 9/16" (14 mm) of deflection per belt when using 7.5 lbs. (3 kg) of force at the center of the belt span between the two sheaves.
If you do not have a weight set to apply the recommended amount of force, a fish scale is a good alternative. Tension can also be checked by pressing firmly on the belts at the center of the span between the two sheaves.
After 24 hours of operation, and for the remainder of belt life, deflection should be 9/16" (14 mm) using 4 to 5.5 lbs. of force.

40', 50', 60', 65' & 70' Models

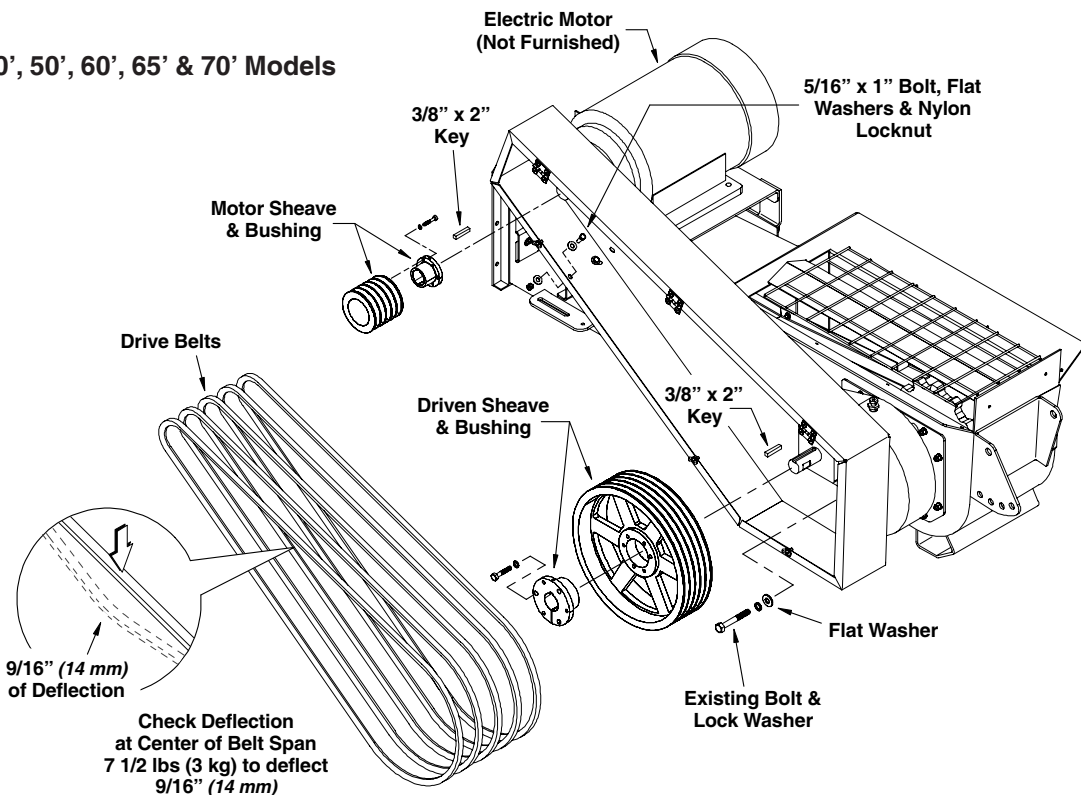

ELECTRIC DRIVE ASSEMBLY

f/ 80', 90' & 100' MODELS

IMPORTANT! The gearbox is shipped *without* oil. Oil must be added before operating the conveyor. Refer to Page 25 for proper filling procedures.

1. Bolt the motor mount tightener bracket to the side of the inlet boot as shown below. Secure bracket using two (2) 3/8" x 1 1/4" bolts, flat washers and nylon locknuts.
2. Attach the threaded tightener rod to the bottom of the motor mount plate using two (2) 1/2" x 1 1/2" bolts, flat washers and nylon locknuts.
3. Thread a 3/4" non-lock nut onto the threaded rod and slide on a 3/4" flat washer. Position the motor mount plate onto the mount brackets welded to the conveyor housing while inserting the threaded rod into the adjustment bracket as shown below.
4. Slide another flat washer onto the rod and thread on a 3/4" non-lock nut (thread the nuts on leaving a good portion of the threaded rod exposed to allow for adjustment when the belts are installed).
5. Loosely bolt the motor mount plate to the mount brackets welded to the inlet boot. Secure using four (4) 1/2" x 1 1/4" carriage bolts, flat washers and nylon locknuts (See illustration below).
6. Attach the upper belt guard mount bracket to the rear motor mount bracket as shown below. Secure the bracket into the round mounting hole using one (1) 5/16" x 1" bolt and nylon locknut.
7. Remove the 1/2" x 4 1/2" bolt and lock washer from the upper rear of the gearbox as shown below. Attach the top belt guard bracket and secure using the bolt and lock washer previously removed.
8. Remove the two (2) bottom 1/2" x 4 1/2" bolts and lock washers from the gearbox (see illustration below). Attach the lower belt guard bracket using the bolts and lock washers previously removed.

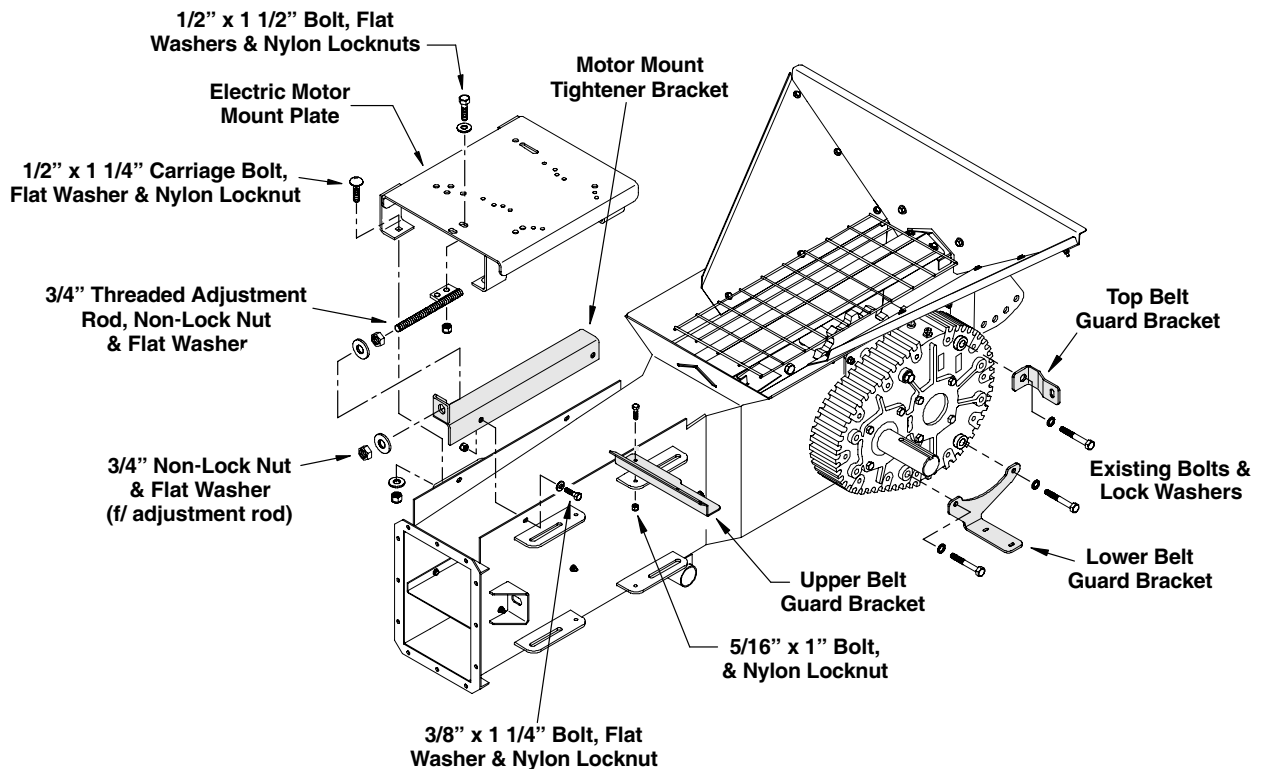

ASSEMBLY PROCEDURES

ELECTRIC DRIVE ASSEMBLY

f/ 80', 90' & 100' MODELS (con't.)

7. Bolt the electric motor to the motor mount plate using the appropriate hardware and hole mount location (**the motor and its mounting hardware are not furnished**).
8. Position the belt guard into place and loosely secure the upper portion of the belt guard to the upper belt guard bracket using two (2) 5/16" x 1" bolts, four (4) flat washers and two (2) nylon locknuts.
Secure belt guard to the top bracket using one (1) 5/16" x 1" bolt, two (2) 5/16" flat washers and one (1) 5/16" nylon locknut.
Secure the belt guard to the lower belt guard bracket using two (2) 5/16" x 1" bolts, four (4) 5/16" flat washers and two (2) 5/16" nylon locknuts.
After the belt guard is properly positioned, tighten all hardware used to mount the belt guard.
10. Insert the 3/8" sq. x 3" long key into the keyway on the gearbox input shaft. Install the 15.4" P.D. diameter shaft and bushing onto the input shaft. Position sheave as close to the gearbox as possible without actually contacting the gearbox. Secure sheave to input shaft.

11. Insert a 3/8" sq. x 2" long key into the keyway on the electric motor shaft. Install the 4.2" P.D. sheave and bushing onto the shaft.
12. Align the sheaves by placing a straight edge along the face of each sheave. Verify sheave alignment, make any necessary adjustments and secure sheave to motor shaft.
13. Install the belts over the sheaves, and using the threaded adjustment rod attached to the front of the motor mount plate, tighten the belts until proper tension has been achieved.

Proper belt tension is approximately 9/16" (14 mm) of deflection per belt when using 7.5 lbs. (3 kg) of force at the center of the belt span between the two sheaves.

If you do not have a weight set to apply the recommended amount of force, a fish scale is a good alternative. Tension can also be checked by pressing firmly on the belts at the center of the span between the two sheaves.

After 24 hours of operation, and for the remainder of belt life, deflection should be 9/16" (14 mm) using 4 to 5.5 lbs. of force.

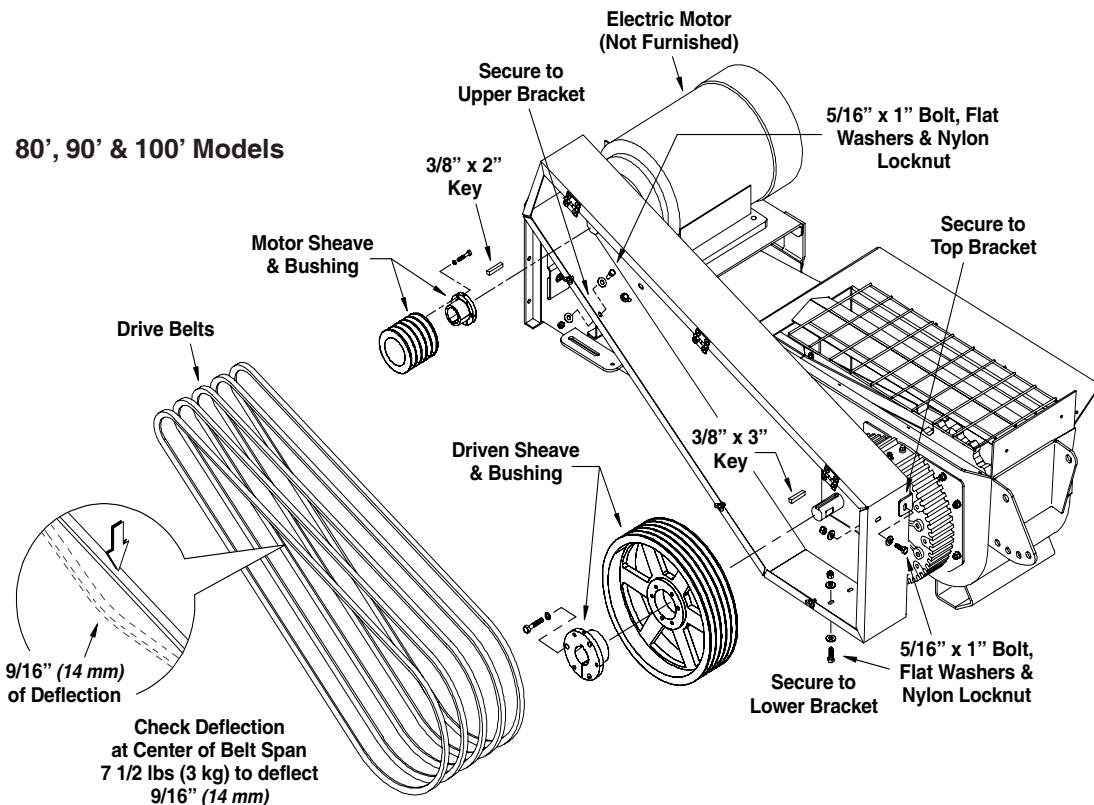

PTO DRIVE ASSEMBLY

40', 50', 60', 65' & 70' MODELS

IMPORTANT! The gearbox is shipped *without oil*. **Oil must be added before operating the conveyor.** Refer to Page 25 for proper filling procedures.

1. Thread one 3/4" non-lock nut onto the threaded tightener rod and slide on a 3/4" flat washer.
2. Guide the tightener rod into the bracket on the inlet housing and set the top of the PTO housing on the upper mount brackets (the bottom of the PTO housing will be positioned on the bottom side of the lower mount brackets as shown below).
3. Loosely bolt the PTO housing to the brackets using four (4) 1/2" x 1 1/2" carriage bolts, flat washers and nylon locknuts (position the carriage bolts with the heads through the slots on the mount brackets).
4. Remove and retain the two existing 5/16" x 3/4" bolts and lock washers on the gearbox that are located nearest to the gearbox input shaft (these bolts can also be determined by placing the belt guard in position and noting which mounting holes will be used to secure the guard to the gearbox, See illustration below).
5. Slide the PTO belt guard into the PTO housing and loosely bolt the housing and guard together using two (2) 5/16" x 1" bolts, four (4) 5/16" flat washers and two (2) nylon locknuts (leave these bolts loose until after the belts have been properly tensioned).
6. Secure the belt guard to the gearbox. Slide the original lock washers onto the 5/16" x 3/4" bolts previously removed, then add one 5/16" flat washer to each of the bolts. Reinsert the bolts through the belt guard and secure belt guard to gearbox.
7. Remove and retain the two 1/2" x 4 1/2" bolts and lock washers securing the rear of the gearbox to the inlet boot (the bolts are located closest to the hitch end, See illustration below). Install the PTO driveline support bracket using the two bolts and lock washers previously removed.

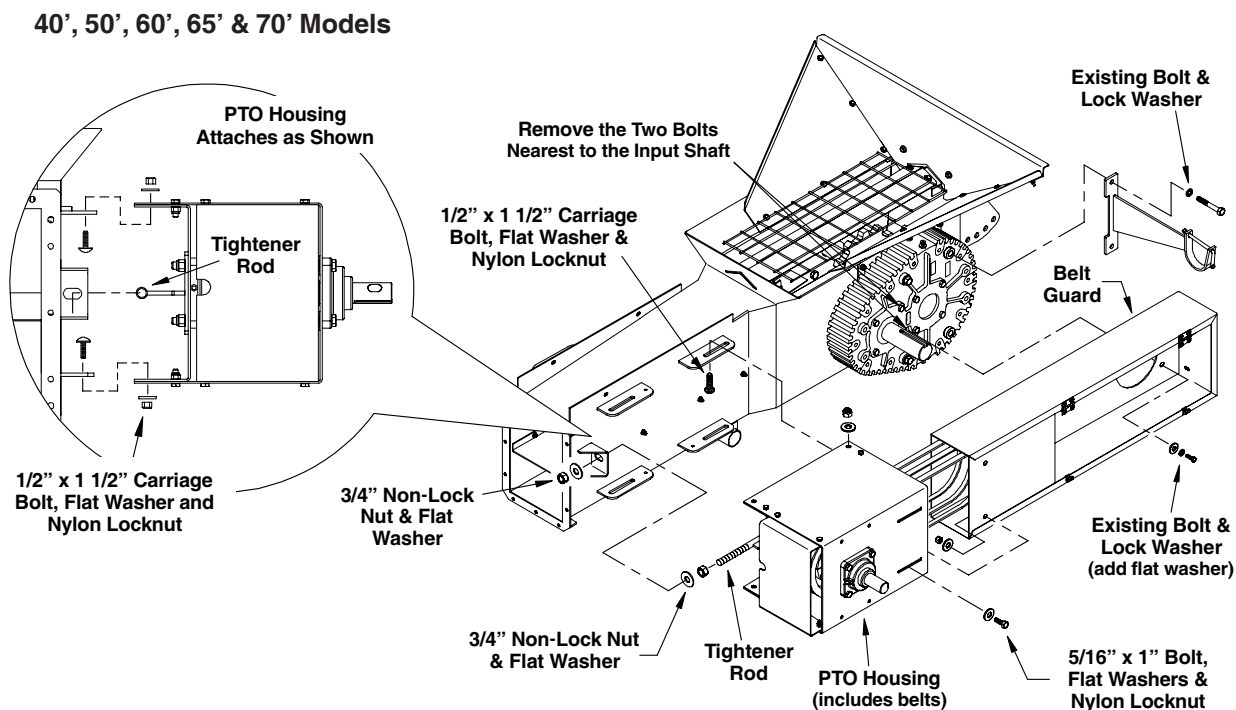

ASSEMBLY PROCEDURES

PTO DRIVE ASSEMBLY (con't.)

40', 50', 60', 65' & 70' Models

8. Bolt the PTO shield hanger to the PTO housing using two (2) 3/8" x 1" bolts and nylon locknuts (the shield bolts directly above the flange bearing and shaft as shown below).
9. Insert a 3/8" sq. x 2" long key into the keyway on the gearbox input shaft and install the sheave and bushing. Make sure the sheave is aligned with the sheave in the PTO housing then secure into place (use a straight edge along the face of each sheave for alignment).
10. Route the belts from inside the PTO housing over the sheave previously installed onto the gearbox input shaft.
11. Install another 3/4" flat washer and 3/4" non-lock nut onto the threaded tightener rod and tighten belts until proper tension has been achieved. Proper belt tension is approximately 1/2" (13 mm) of deflection when belts are firmly pressed in the center of the span between the two sheaves.
Tighten the carriage bolts securing the housing to the brackets on the inlet boot and tighten the two bolts securing the housing and guard together.
12. Slide the u-joint shield over the end of the PTO driveline. Insert a 3/8" sq. x 2" long key into the keyway on the shaft extending from the PTO housing assembly.
Attach the 1 1/2" bore end of the driveline to the shaft making sure the key remains in place and secure driveline yoke to shaft (See illustration below for proper yoke and shaft connection).
13. Secure the u-joint shield to the shield hanger using two (2) 3/8" x 1" bolts and nylon locknuts.
14. Position the PTO driveline into the driveline storage support and pin into place. **The driveline should always be stored in the storage support when not in use and during transport.**
15. Snap the Operator's manual container into the holder located on the right side of the inlet boot (the container also includes extra shear bolts for the PTO/tractor connection).

40', 50', 60', 65' & 70' Models

IMPORTANT! For the setscrew in the PTO driveline yoke to be properly engaged on the sheave shaft, slide the yoke onto the shaft until the setscrew will sit on the flat portion of the shaft. Do Not extend the shaft beyond the inside edge of the yoke.

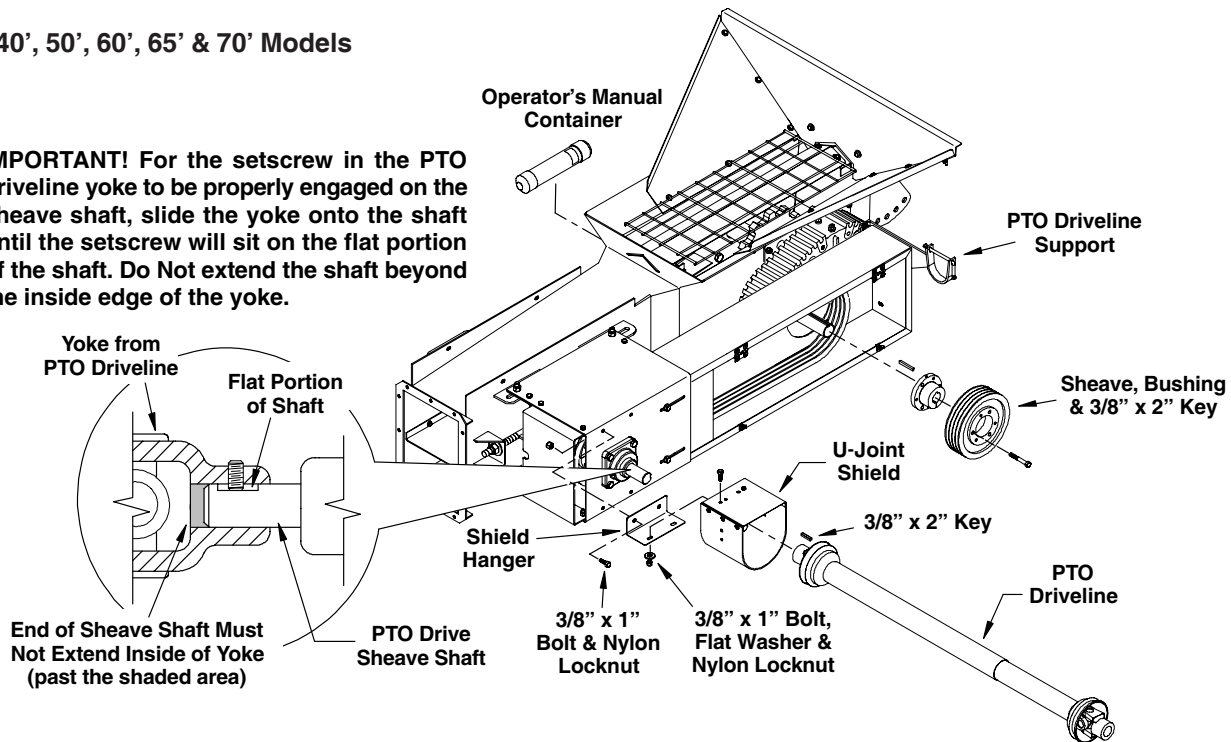

PTO DRIVE ASSEMBLY 80', 90' & 100' MODELS

IMPORTANT! The gearbox is shipped *without* oil. **Oil must be added before operating the conveyor.** Refer to Page 25 for proper filling procedures.

1. Thread one 3/4" non-lock nut onto the threaded tightener rod and slide on a 3/4" flat washer.
2. Guide the tightener rod into the bracket on the inlet housing and set the top of the PTO housing on the upper mount brackets (the bottom of the PTO housing will be positioned on the bottom side of the lower mount brackets as shown below).
3. Loosely bolt the PTO housing to the brackets using four (4) 1/2" x 1 1/2" carriage bolts, flat washers and nylon locknuts (position the carriage bolts with the heads through the slots on the mount brackets).
4. Slide the PTO belt guard into the PTO housing and loosely bolt the housing and guard together using two (2) 5/16" x 1" bolts, four (4) 5/16" flat washers and two (2) nylon locknuts (leave these bolts loose until after the belts have been properly tensioned).
5. Remove and retain the two 1/2" x 4 1/2" bolts and lock washers securing the rear of the gearbox to the inlet boot (the bolts are located closest to the hitch end, See illustration below). Install the PTO driveline support bracket using the two bolts and lock washers previously removed.
6. Secure the belt guard to the PTO support bracket using three (3) 5/16" x 1" bolts, six (6) flat washers and three (3) nylon locknuts.

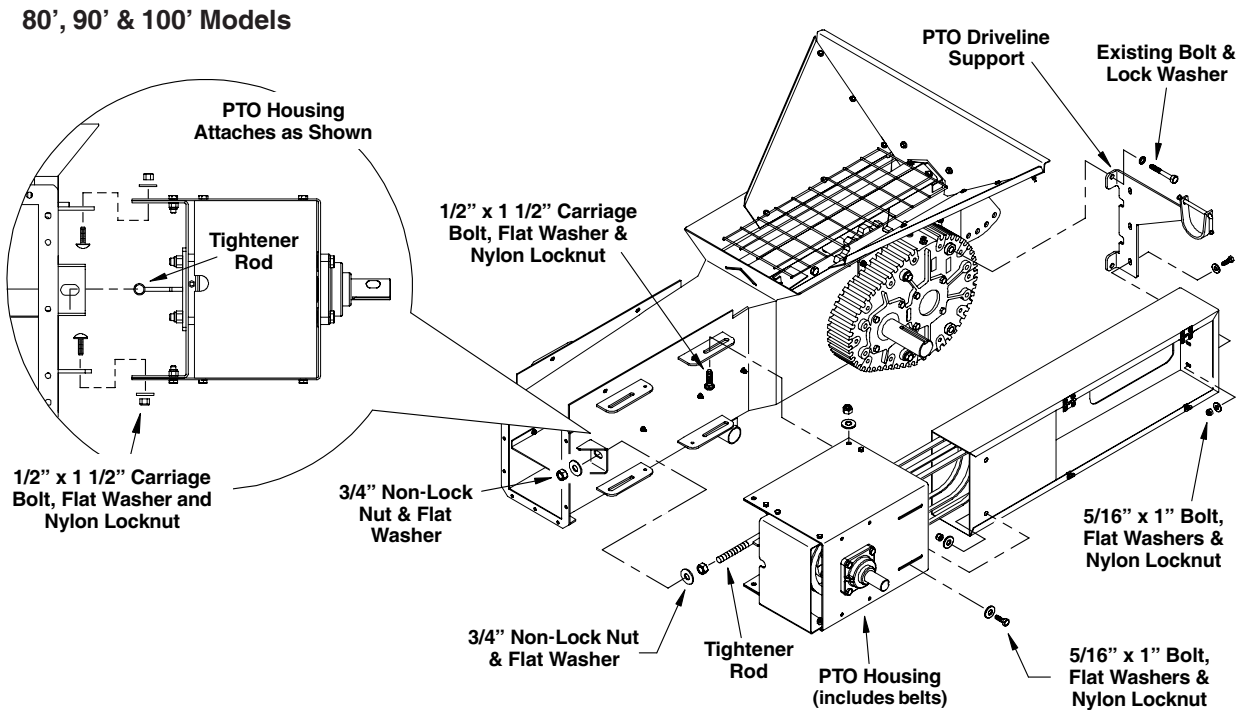

ASSEMBLY PROCEDURES

PTO DRIVE ASSEMBLY (con't.)

80', 90' & 100' Models

8. Bolt the PTO shield hanger to the PTO housing using two (2) 3/8" x 1" bolts and nylon locknuts (the shield bolts directly above the flange bearing and shaft as shown below).
9. Insert a 3/8" sq. x 3" long key into the keyway on the gearbox input shaft and install the sheave and bushing. Make sure the sheave is aligned with the sheave in the PTO housing then secure into place (use a straight edge along the face of each sheave for alignment).
10. Route the belts from inside the PTO housing over the sheave previously installed onto the gearbox input shaft.
11. Install another 3/4" flat washer and 3/4" non-lock nut onto the threaded tightener rod and tighten belts until proper tension has been achieved. Proper belt tension is approximately 1/2" (13 mm) of deflection when belts are firmly pressed in the center of the span between the two sheaves.
Tighten the carriage bolts securing the housing to the brackets on the inlet boot and tighten the two bolts securing the housing and guard together.
12. Slide the u-joint shield over the end of the PTO driveline. Insert a 3/8" sq. x 2" long key into the keyway on the shaft extending from the PTO housing assembly.
Attach the 1 1/2" bore end of the driveline to the shaft making sure the key remains in place and secure driveline yoke to shaft (See illustration below for proper yoke and shaft connection).
13. Secure the u-joint shield to the shield hanger using two (2) 3/8" x 1" bolts and nylon locknuts.
14. Position the PTO driveline into the driveline storage support and pin into place. **The driveline should always be stored in the storage support when not in use and during transport.**
15. Snap the Operator's manual container into the holder located on the right side of the inlet boot (the container also includes extra shear bolts for the PTO/tractor connection).

80', 90' & 100' Models

IMPORTANT! For the setscrew in the PTO driveline yoke to be properly engaged on the sheave shaft, slide the yoke onto the shaft until the setscrew will sit on the flat portion of the shaft. Do Not extend the shaft beyond the inside edge of the yoke.

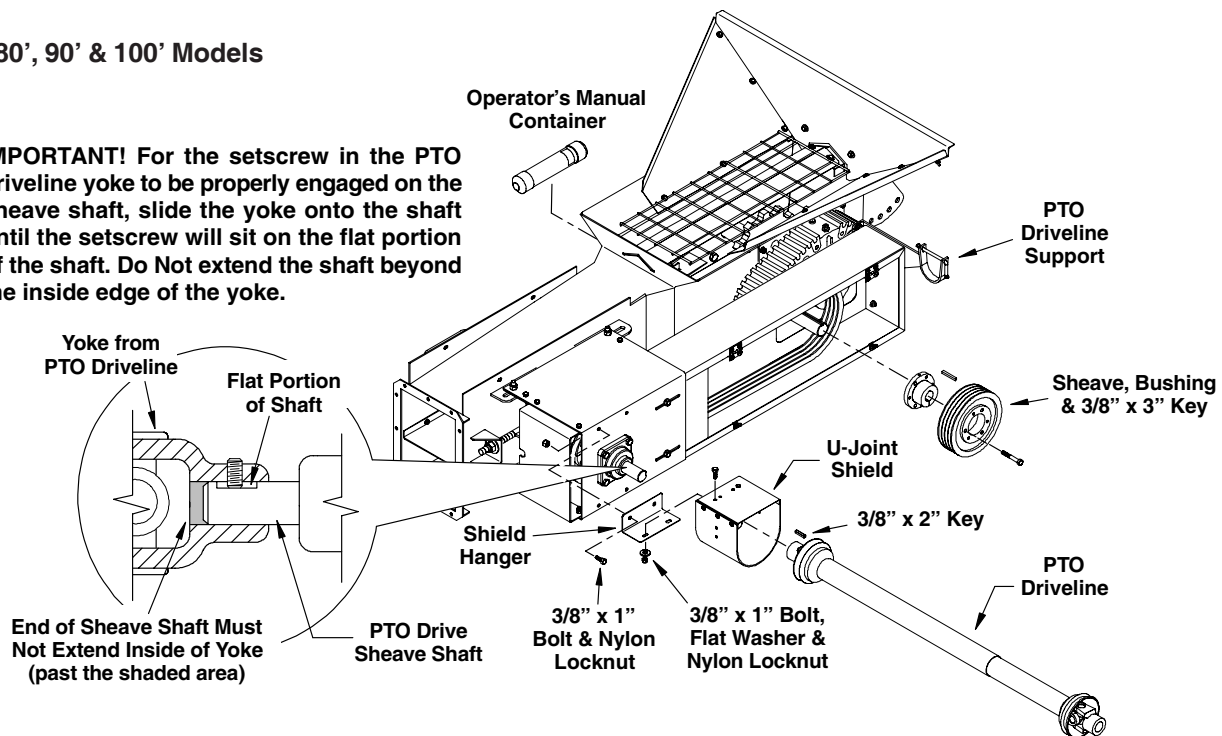

HITCH & HITCH JACK ASSEMBLY

1. Attach the hitch to the inlet end of the conveyor as shown in Fig. 26. Use the 3/4" x 11" bolt and nylon locknut to secure the hitch to the mounting plates. Tighten only enough so that the hitch can still pivot freely on the bolt.

Pivot the hitch so one of the locating holes at the bottom of the hitch mount plate align with the tab on the hitch and secure with the 5/8" x 1 1/2" bolt and nylon locknut.

This bolt will be the hitch locating bolt. The bolt will be removed and reinserted into the appropriate hole depending on whether the conveyor is being transported or being positioned next to the bin (when the bolt is removed, the hitch can be rotated to desired position).

2. Install the screw type hitch jack to the jack mount tube on the side of the hitch and secure using the attached locking pin.

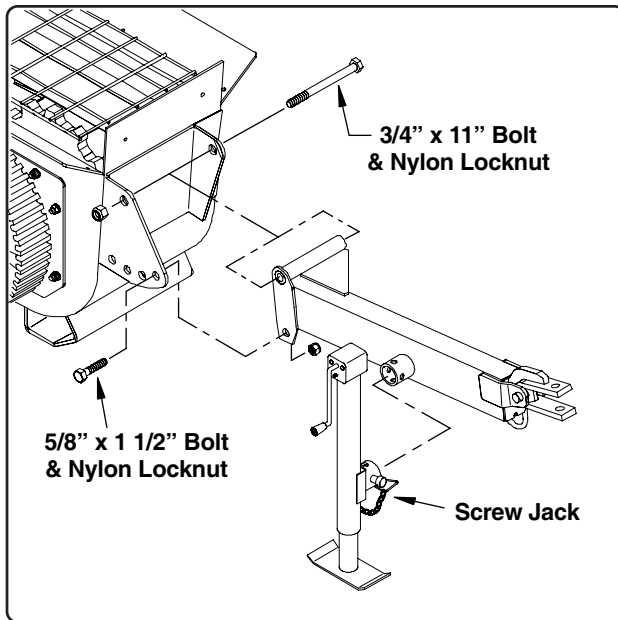

Fig. 26

HOPPER ASSEMBLY

1. Install the front hopper plate to the inlet boot using two (2) 1/4" x 1" bolts, four (4) flat washers and two (2) nylon locknuts (See Fig. 27).
2. Attach the left and right side hopper plates to the front plate and to the inlet boot as shown (the side plates will attach to the top side of the front plate). Secure each hopper plate using five (5) 1/4" x 1" bolts, ten (10) flat washers and five (5) nylon locknuts.

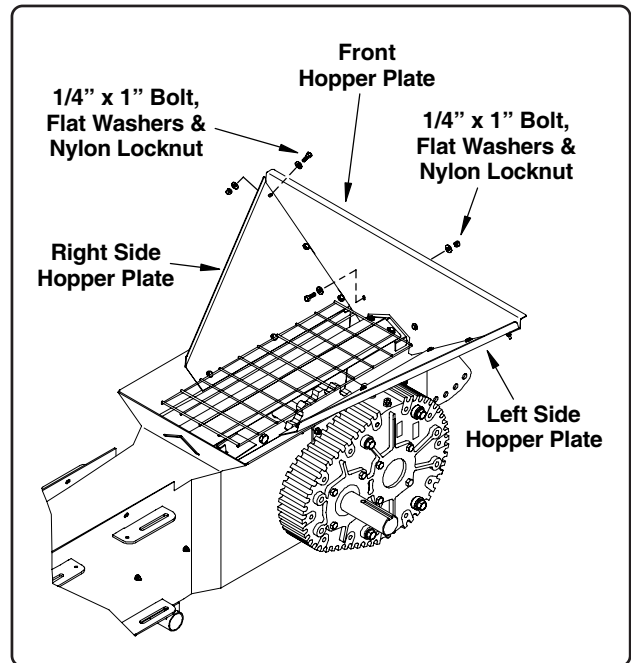

Fig. 27

ASSEMBLY PROCEDURES

DROP LEG JACK ASSEMBLY

1. Slide the spacer plate onto the tube of the jack mount weldment (See Fig. 28).
Insert the jack mount weldment, w/ spacer plate, into the mount tube on the side of the inlet housing.
2. Position the outer angle plate over the outside tube of the jack mount weldment, See Fig. 28 (the jack mount weldment flange will be captured between the outer angle plate and spacer plate).

3. Using four (4) 3/8" x 1 1/4" bolts and nylon locknuts, secure the outer angle plate and spacer plate to the mount tube on the inlet housing.
4. Install the drop leg jack onto the jack mount weldment tube and secure using the attached pin provided with the jack.

The jack can be rotated to various positions by removing the bent pin securing the outer angle plate and spacer plate to the mount tube on the inlet. Make sure to replace the bent pin and secure it when transporting the conveyor.

The jack can also be removed from the conveyor and stored in the towing vehicle or other storage area if desired.

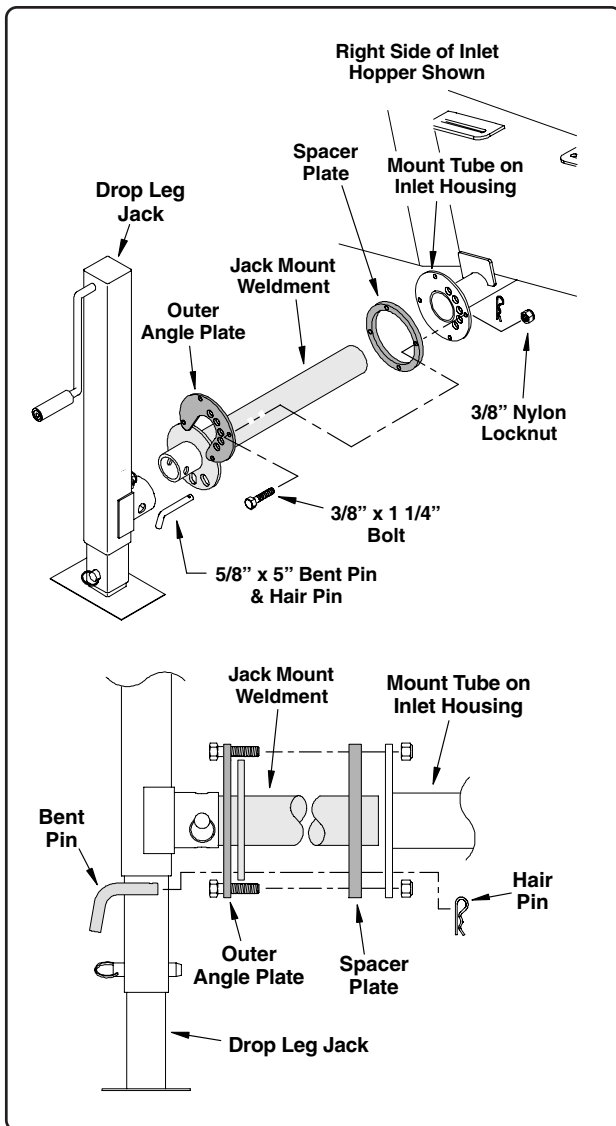

Fig. 28

UNDERCARRIAGE ASSEMBLY

f/ 40', 50', 60' & 65' MODELS



WARNING! Do Not rely solely on hydraulic or mechanical jacks for support. Use jack stands or equivalent to support the undercarriage and axle.



Keep hands, feet and other body parts out from beneath the undercarriage as it is being raised or when it is in the raised position

Assemble Undercarriage

Install Hubs and Spindles

The hubs and spindles for the 40' Models may have already been assembled and packed with grease at the factory. If they have, install the hub and spindle into the axle as stated in Step 2 below.

If they have not, the following instructions for the 50', 60' & 65' Models can be used.

Tapered roller bearings in the hubs are standard parts on all conveyor axles and should be repacked with grease annually, or as needed determined by usage. Refer to the Lubrication & Maintenance Section in this manual for proper procedures.

1. Raise and support the axle high enough to allow the tire to be installed after installation of the hub and spindle (use jack stands or equivalent to support the axle).
2. Apply an anti-seize compound to the spindle and insert the spindle into the axle (See Fig. 29). Align the hole in the spindle with the hole in the axle and secure using one 1/2" x 4" bolt and nylon locknut (40' models use a 1/2" x 3 1/2" bolt).
3. Pack the inner cone bearing with a good quality automotive axle grease. Insert the inner bearing into the hub and press on the grease seal.

Install the hub onto the spindle being careful not to damage the lip of the seal.

Fill the hub cavity approximately 1/3 full of grease. Pack the outer cone bearing and insert into the hub.

4. Install the flat washer and slotted nut. Tighten the nut to seat the bearings. Keep tightening the slotted nut until the hub begins to bind as it being rotated. Back off the slotted nut to the next slot and install the 5/32" x 1 3/4" cotter pin (5/32" x 1 1/4" for 40' Models). Install the dust cap.
5. Mount the tire and rim and secure with the lug bolts provided. Check tires for proper pressure. **Pressure not to exceed 45 PSI (310 kPa).**

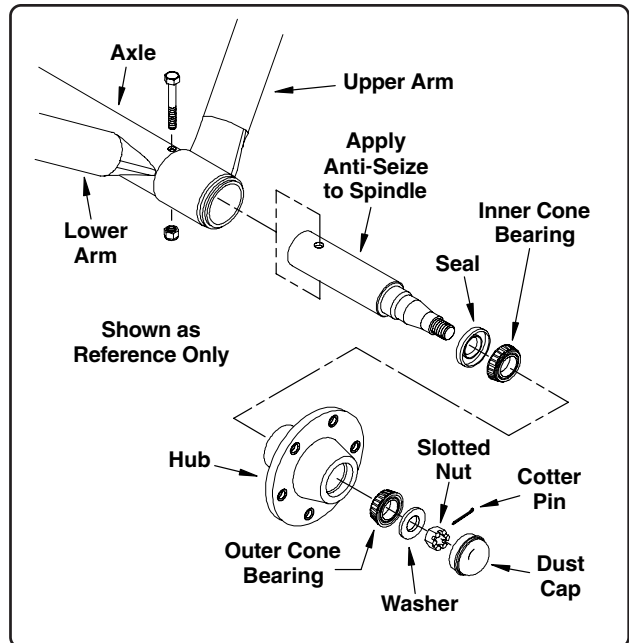

Fig. 29

ASSEMBLY PROCEDURES

UNDERCARRIAGE ASSEMBLY

f/ 40', 50', 60' & 65' MODELS (con't.)



WARNING! Keep hands, feet and other body parts out from under the conveyor when the conveyor is being raised or when it is in the raised position.



CAUTION! The slide-and-pulley assembly will slide freely along the tracks. Keep hands and fingers away from these pinch point areas during the assembly process.

Assemble Undercarriage to Conveyor

The undercarriage and conveyor shown on Page 61 may differ in appearance than your Model. It is shown as a reference only. The assembly and installation of the undercarriage to the conveyor is the same for the 40', 50', 60' and 65' Models.

1. If the undercarriage is still supported with jack stands, remove the jack stands and position the undercarriage on the ground.

Position the discharge end of the conveyor above the trolley (slide & pulley assembly) located at the end of the undercarriage.

2. Remove and retain the four nylon locknuts securing the upper stop to the bottom of the conveyor housing (See illustration on Page 61).

Align the slide-and-pulley assembly with the tracks and carefully slide the pulley assembly onto the tracks (the tracks should be positioned between the rollers and the flange of the slide-and-pulley assembly frame (See illustration on Page 61).

Be cautious of pinch points when installing the slide-and-pulley assembly.

3. Reinstall the upper stop and secure using the nylon locknuts previously removed.

It is recommended to strap the slide-and-pulley assembly to the upper stop to prevent it from rolling during the remainder of the assembly process.

4. Attach the lower undercarriage arms to the undercarriage mount welded to the bottom side of the conveyor housing.

Using four (4) 1/2" x 1 3/4" bolts, lock washers and non-lock nuts, secure the undercarriage mount clamp to the conveyor as shown on Page 61.

5. Remove the temporary strapping from the slide-and-pulley assembly and upper stop.

ASSEMBLY PROCEDURES

UNDERCARRIAGE ASSEMBLY

f/ 40', 50', 60' & 65' MODELS (con't.)

Undercarriage Installation 40', 50', 60' & 65' Models

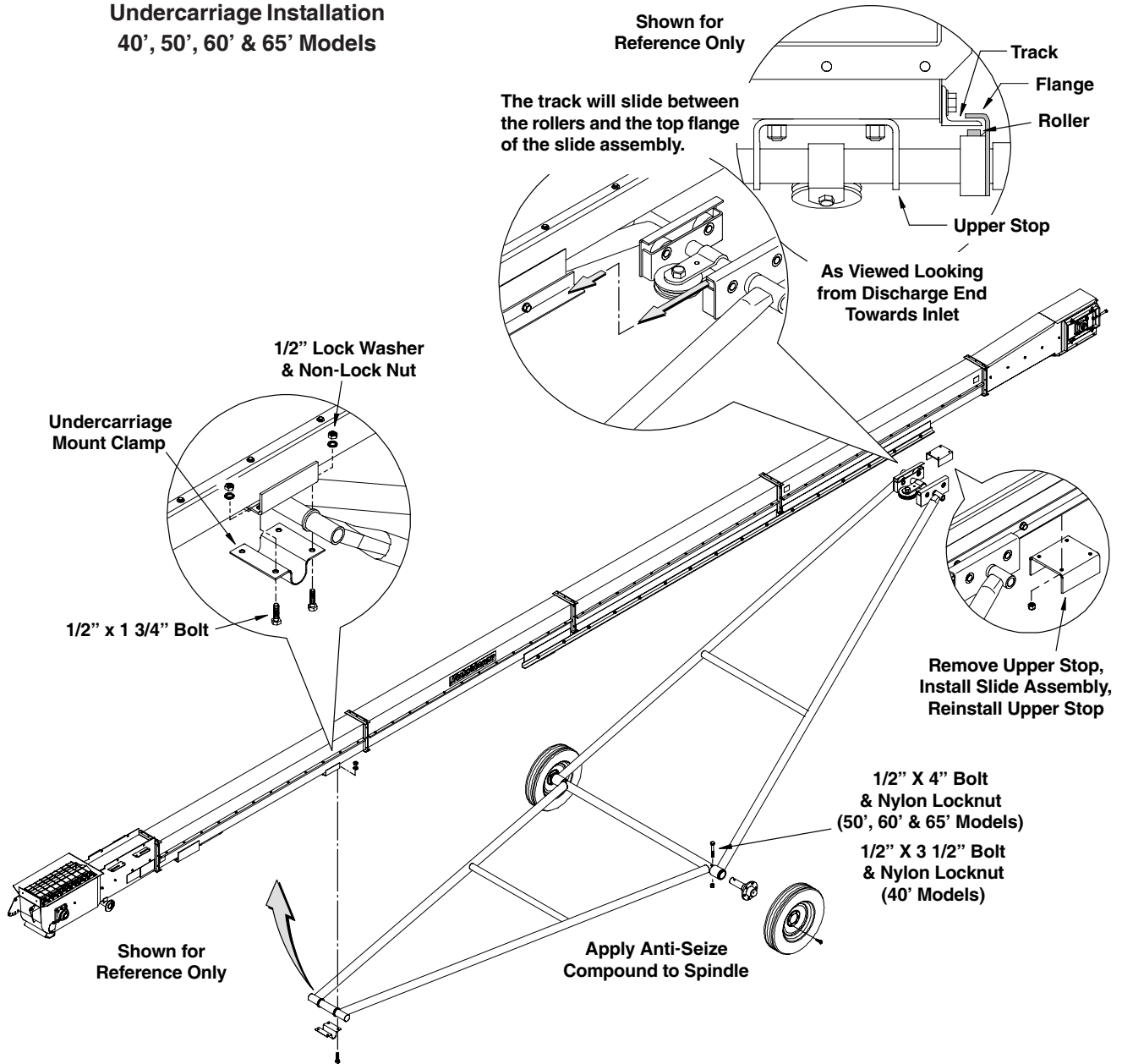



ASSEMBLY PROCEDURES

WINCH MOUNT & CABLE ROUTING

f/ 40', 50', 60' & 65' MODELS

 **WARNING!** Keep hands away from winch drum during winch operation.

 Never fully extend the cable, always leave three complete wraps of cable around the winch drum.

 Never operate the winch with wet or oily hands, always use a firm grip on the handle.

Attach Winch to Conveyor

The illustration of the conveyor shown on Page 63 may differ in appearance than your Model. It is shown as a reference only. The assembly and installation of the winch and routing of the cable is the same for the 40', 50', 60' and 65' Models.

For additional winch information, follow the instructions and precautions listed in the material provided by the winch manufacturer.

1. Install the handle onto the winch. Align the slot in the handle with the winch handle shaft and slide handle onto shaft. Secure the handle using the nut provided with the winch. **IMPORTANT! Do Not remove the two existing nuts already on the winch handle shaft.**

2. Attach the winch to the winch mount plate located just to the front of the inlet hopper. The winch drum should be facing the discharge end of the conveyor. Secure the winch using three (3) 3/8" x 1" bolts, flat washers, lock washers and non-lock nuts.

3. Attach the 1/4" dia. (6.5 mm) lift cable to the winch drum so that as the handle is turned clockwise, the cable wraps from the bottom of the drum (cable lengths for the various models are shown at the bottom of the next column).

Insert the cable end from inside the drum. Pass the cable through one of the round holes on the side of the drum until the cable extends approximately 1" (25 mm) past the two square holes in the drum side.

4. Clamp the cable to the outside of the drum with the cable keeper and secure using two (2) 3/16" x 3/4" carriage bolts, lock washers and non-lock nuts (make sure the carriage bolt heads are on the inside of the drum, See Fig. 30).

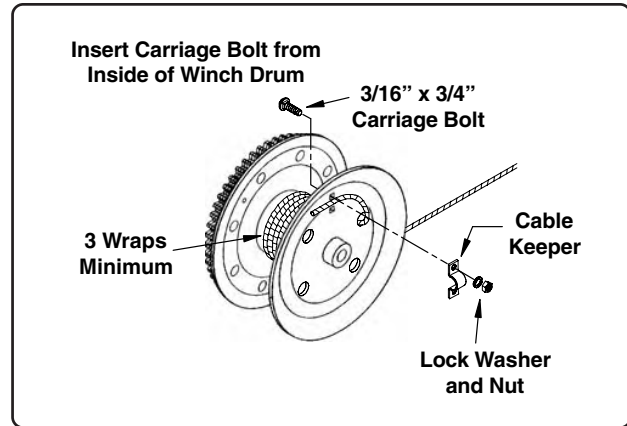

Fig. 30

5. Keep the cable taut and turn handle to verify cable is winding onto the drum properly. Turn handle until the cable wraps around the drum three (3) times.

CAUTION! The cable keeper alone will not hold the weight of the conveyor. There should be enough cable length so that when the conveyor is in the full down position, there is a minimum of three (3) cable wraps around the drum.

If there are not three wraps of cable around the winch drum when the conveyor is fully lowered, then the cable must be replaced with a longer one.

6. Route the cable up and around the pulley on the trolley assembly keeping the cable between the pulley and cotter pin.

Route back down and around the lower pulley and up again to the trolley assembly (keep the cable taut as it is being routed, this will help keep it from unraveling on the winch drum).

Secure the cable to the trolley shaft using two 1/4" cable clamps (make sure the u-bolt portion of the clamp is against the loose end of the cable).

Cable Lengths:

40' Models: 1/4" dia. x 51' long (6.5 mm x 15.54 m)

50' Models: 1/4" dia. x 70' long (6.5 mm x 21.34 m)

60' Models: 1/4" dia. x 82' long (6.5 mm x 24.99 m)

65' Models: 1/4" dia. x 93' long (6.5 mm x 28.35 m)

An optional electric and hydraulic winch are also available for use with these Models.

Refer to Pages 76 and 77 for proper installation procedures of these winches.

ASSEMBLY PROCEDURES

WINCH MOUNT & CABLE ROUTING

f/ 40', 50', 60' & 65' MODELS (con't.)

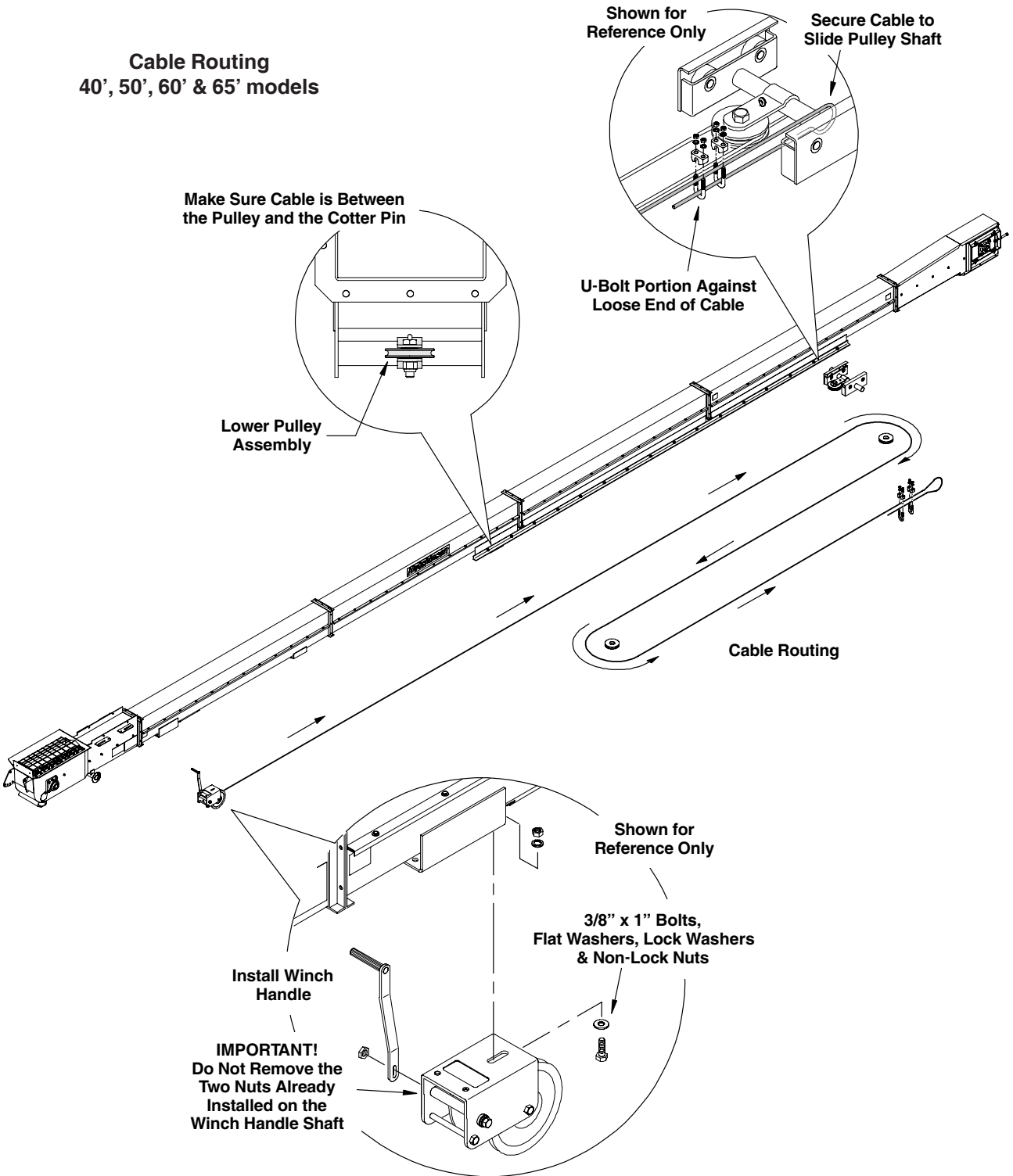

ASSEMBLY PROCEDURES

UNDERCARRIAGE ASSEMBLY

f/ 70' MODELS

Assemble Undercarriage

The two lower undercarriage arms have the same part number and the two upper undercarriage arms have the same part number. When assembling the arms onto the axle, make sure to keep the angle of the arms towards the inside of the axle tube (See Page 65).

IMPORTANT! Do Not install the hubs onto the spindles until after the undercarriage arms have been installed.

1. Slide the lower undercarriage arms onto the axle (note the two holes in the axle tube, slide the arms past the second hole).
2. Slide the axle collar onto the axle and align the holes in the collar with the second set of holes in the axle (you can temporarily insert the 1/2" x 4" bolt through the collar and axle to help keep the arms in place during assembly).
3. Slide the upper carriage arms onto the axle so they contact the axle collar (the arms should be angled towards the inside as shown on Page 65).
4. Install the 52" (1.32 m) long cross brace between the lower arms and secure to the mounting ears using two (2) 5/8" x 4 1/2" bolts and nylon locknuts (the crossbrace will be positioned between the mounting ears as shown on Page 65).
5. Install the 76" (1.93 m) and the 42 1/4" (1.07 m) long cross braces to the upper set of undercarriage arms in the same manner. Secure using the 5/8" x 4 1/2" bolts and nylon locknuts provided.
6. If the 1/2" x 4" bolt was temporarily installed through the collar, remove it now.

Apply a thin coat of anti-seize compound to the axle spindle and insert the spindle into the axle. Align the first hole at the end of the spindle with the hole in the axle and axle collar. Secure the spindle using one (1) 1/2" x 4" bolt and nylon locknut (See Fig. 31 and illustration on Page 65).

Install the collar with set screws onto the axle and align the setscrews with the holes in the axle. Tighten the setscrews (the setscrews will pass through the axle holes and tighten against the spindle).

7. Install the hubs. Using a good automotive type axle grease, pack the bearing cones with grease. Fill the hub cavity with grease until about 1/3 full.

8. Install the inner cone bearing into the hub and press on the grease seal.
9. Install the hub onto the spindle being careful not to damage the lip of the grease seal.

Slide the outer cone bearing onto the spindle and install the flat washer and slotted nut. Tighten the nut to seat the bearings. Keep tightening the slotted nut until the hub begins to bind as it is being rotated.

Back off the slotted nut to the next slot and install the 1/8" x 1 1/2" long cotter pin. Install the dust cap. Repeat this procedure for the opposite hub.

10. Mount the tires onto the hubs and secure using the lug bolts provided.

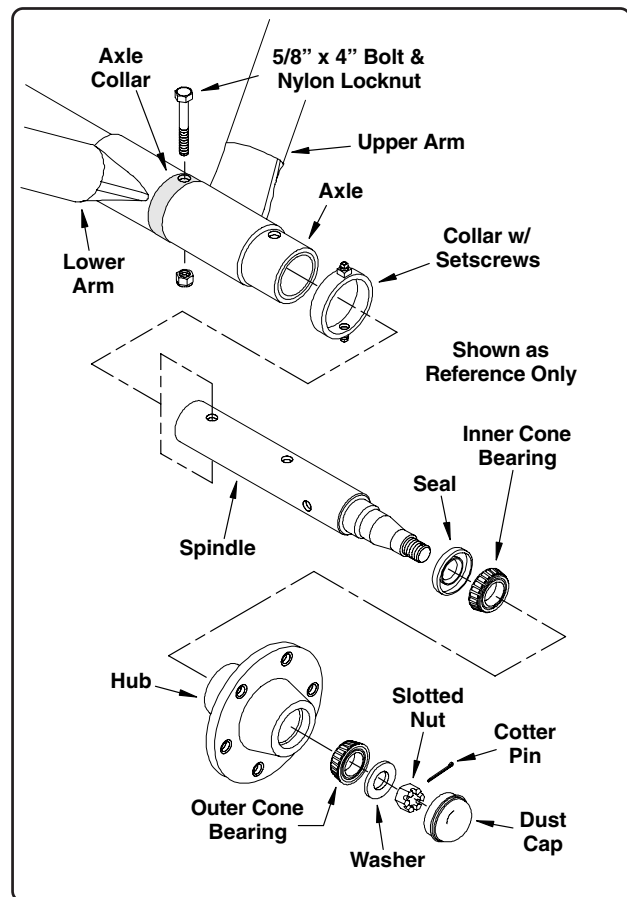
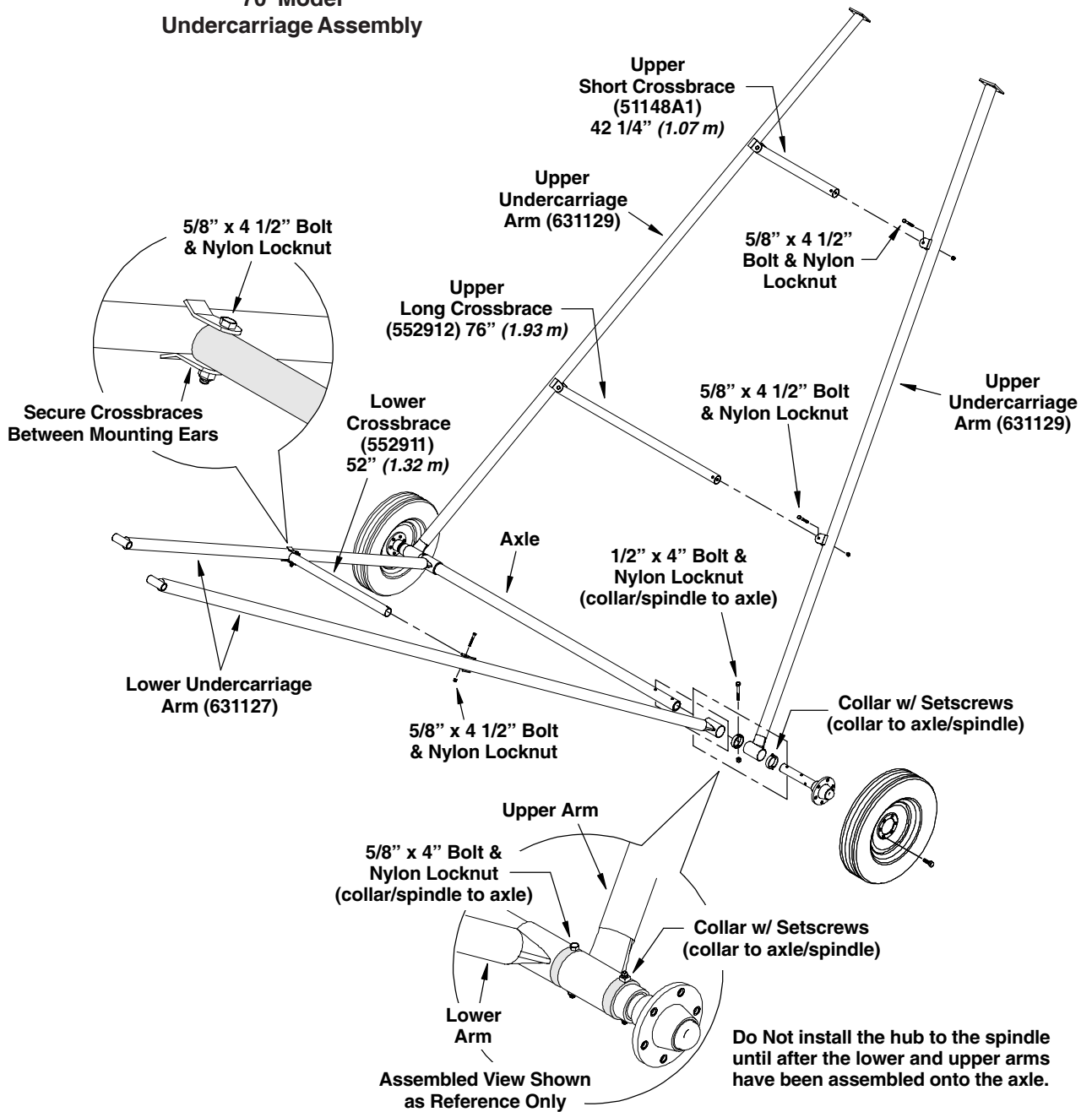

Fig. 31

UNDERCARRIAGE ASSEMBLY

f/ 70' MODELS (con't.)

70' Model Undercarriage Assembly



ASSEMBLY PROCEDURES

UNDERCARRIAGE ASSEMBLY

f/ 70' MODELS (con't.)

Attach Undercarriage to Conveyor



WARNING! Keep hands, legs and other body parts out from under the conveyor when it is being raised by the hoist or by other means.



Do Not rely solely on hydraulic or mechanical jacks and/or overhead hoist to support the conveyor. Always use jack stands, saw horses or equivalent for support.



CAUTION! The slide-and-pulley assembly will slide freely along the tracks. Keep hands and fingers away from the pinch point areas during the assembly process.



After the upper undercarriage stop has been installed, it is recommended to strap the slide and pulley assembly to the stop to prevent the assembly from sliding while the remainder of the undercarriage assembly is carried out.

Install Upper Stop and Pulley Assembly

1. Locate the slide-and-pulley assembly from the box of parts. From the discharge end of the conveyor, slide the pulley assembly onto the tracks far enough to allow the upper undercarriage stop to be mounted (the upper stop will mount to the four predrilled holes on the bottom side of the tracks, face the pulley towards the inlet end of the conveyor as shown on Page 67).
 2. Bolt the upper undercarriage stop to the conveyor using four (4) 1/2" x 1 1/4" bolts, flat washers and nylon locknuts (see illustration on Page 67).
 3. Secure the slide-and-pulley assembly to the upper stop with straps or a similar method to prevent it from sliding during the remainder of the assembly process.
1. Raise the conveyor just high enough to position it over the undercarriage assembly (Do Not raise conveyor by the extreme ends of either the discharge or the inlet end).
 2. Position the lower undercarriage arms to the outside of the undercarriage mount as shown in the illustration on Page 67. Insert the undercarriage mounting pin through the lower arms and mounting tube, and install the mounting pin collar onto the end of the mounting pin. Secure the collar using one (1) 3/8" x 3" bolt and nylon locknut.
 3. Position the upper undercarriage arms near the pulley assembly strapped to the upper undercarriage stop.
If the upper arms can be attached without removing the strap temporarily holding the pulley assembly to the upper stop, attach the arms to the mount plates on the pulley assembly.
Secure each arm using four (4) 5/8" x 2" bolts, lock washers and non-lock nuts. Remove strap from upper stop and pulley assembly.
If the arms cannot be attached because of the strapping material, carefully remove the strap (the pulley assembly will be able to roll freely, be aware of the pinch point areas). Secure each arm using the 5/8" x 2" bolts, lock washers and non-lock nuts.

ASSEMBLY PROCEDURES

UNDERCARRIAGE ASSEMBLY

f/ 70' MODELS (con't.)

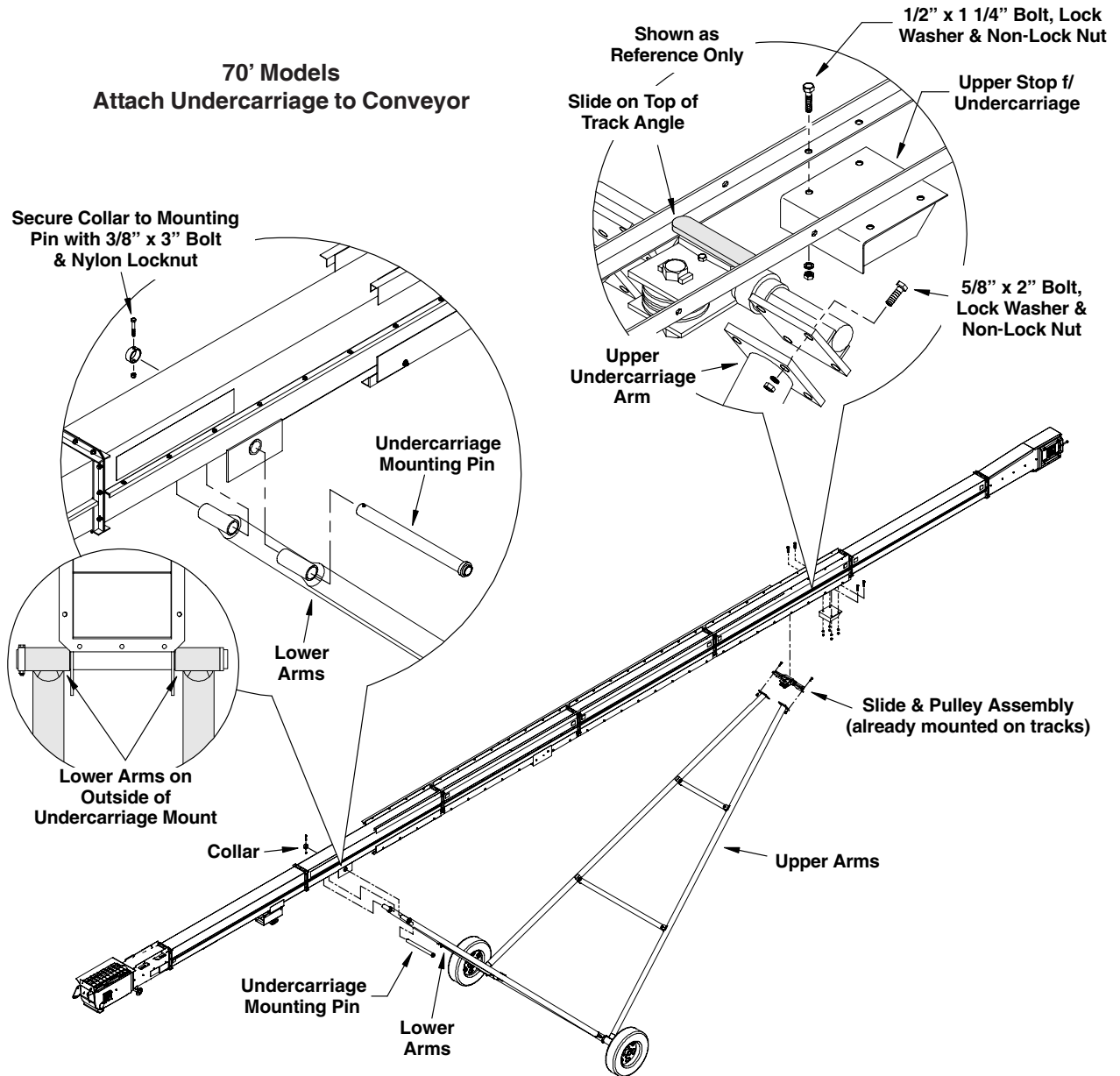

ASSEMBLY PROCEDURES

UNDERCARRIAGE ASSEMBLY

f/ 80', 90' & 100' MODELS

Assemble Undercarriage

The following instructions show a reference number in parenthesis (), this number refers to the item shown on Page 69 in the assembly illustration.

Assembly is the same for the 80', 90' & 100' Models.

IMPORTANT! Do Not install the hubs onto the spindles until after the undercarriage arms have been installed.

1. Slide the lower undercarriage arms (Ref. 1) onto the axle until they contact the collar welded on the axle (the arms should be angled towards the inside as shown on Page 69).
2. Slide the axle collars (Ref. 2) onto the axle until they contact the lower arm previously installed.
3. Slide the upper carriage arms (Ref. 3) onto the axle so they contact the axle collar (the arms should be angled towards the inside as shown on Page 69).
4. Install the cross braces (Ref. 4 & 5) between the lower arms and secure to the mounting ears using two (2) 5/8" x 4 1/2" bolts and nylon locknuts (the crossbraces will be positioned between the mounting ears as shown on Page 69).
5. Install the cross braces (Ref. 6 & 7) to the upper set of undercarriage arms in the same manner. Secure using the 5/8" x 4 1/2" bolts and nylon locknuts provided.
6. **Apply a thin coat of anti-seize compound** to the axle spindle (Ref. 8), insert the spindle into the axle. Align the first hole at the end of the spindle with the holes in the axle and axle collar. Secure the spindle using one (1) 1/2" x 5 1/2" bolt and nylon locknut (See Fig. 32 and the illustration on Page 69).
Install the collar with set screws (Ref. 9) onto the axle. Align the setscrews with the holes in the axle and tighten the setscrews (the setscrews will pass through the axle holes and tighten against the spindle).
7. Install the hubs (Ref. 10). The hubs will need to be assembled onto the axle spindle. Refer to the following procedures for hub assembly.
Using a good automotive type axle grease, pack the bearing cones with grease. Fill the hub cavity with grease until about 1/3 full.

8. Install the inner cone bearing into the hub and press on the grease seal.
9. Install the hub onto the spindle being careful not to damage the lip of the grease seal.
Slide the outer cone bearing onto the spindle and install the flat washer and slotted nut. Tighten the nut to seat the bearings. Keep tightening the slotted nut until the hub begins to bind as it is being rotated. Back off the slotted nut to the next slot and install the 1/8" x 1 1/2" long cotter pin. Install the dust cap. Repeat this procedure for the opposite hub.
10. Mount the tires (Ref. 11) onto the hubs and secure using the lug bolts provided.

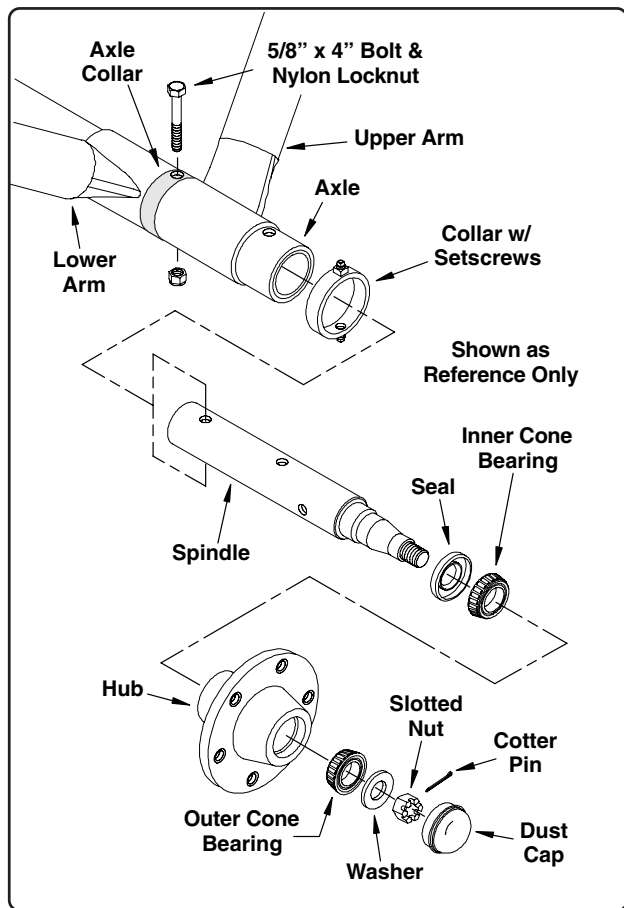
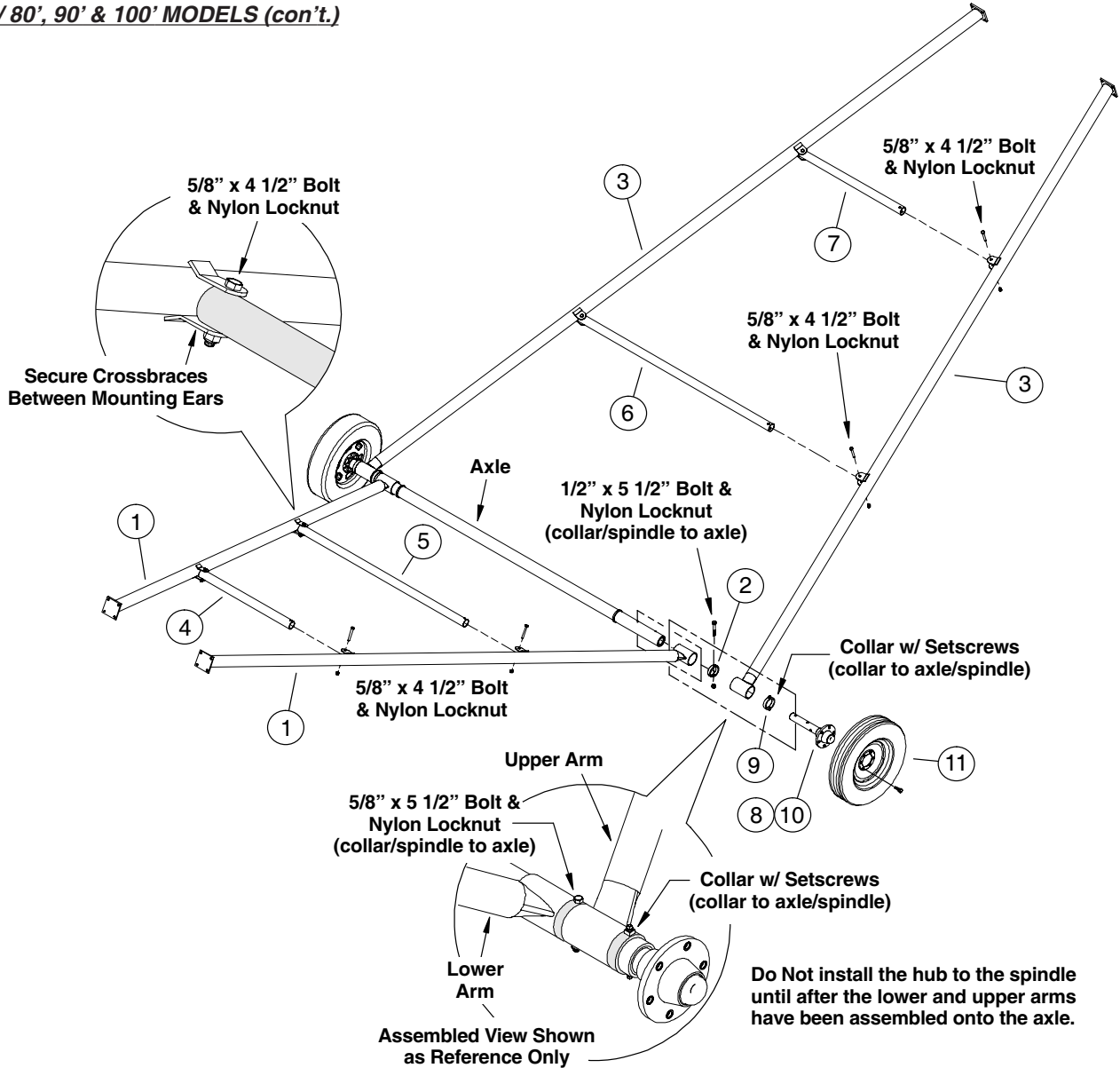

Fig. 32

UNDERCARRIAGE ASSEMBLY
f/ 80', 90' & 100' MODELS (con't.)



Ref. No.

1 Lower Arms

- 80' Models 6973A1, 18'-8 1/2" (5.70 m)
- 90' Models 631079, 21'-11" (6.68 m)
- 100' Models 6971A1, 22'-5" (6.83 m)

3 Upper Arms

- 80' Models 6971A1, 22'-5" (6.83 m)
- 90' Models 631080, 24'-8" (7.52 m)
- 100' Models 6972A1, 26'-4" (8.03 m)

4 Crossbrace, Short (lower arm)

- 80' Models 552748, 39 3/4" (1.01 m)
- 90' Models 51148A1, 42 1/4" (1.07 m)
- 100' Models 552815, 47 11/16" (1.21 m)

Ref. No.

5 Crossbrace, Long (lower arm)

- 80' Models 552750, 72" (1.83 m)
- 90' Models 51172A1, 95 5/8" (2.43 m)
- 100' Models 552817, 90 3/16" (2.29 m)

6 Crossbrace, Long (upper arm)

- 80' Models 552751, 81" (2.06 m)
- 90' Models 51172A1, 95 5/8" (2.43 m)
- 100' Models 552818, 99 5/16" (2.52 m)

7 Crossbrace, Short (upper arm)

- 80' Models 552749, 43 1/2" (1.10 m)
- 90' Models 51148A1, 42 1/4" (1.07 m)
- 100' Models 552816, 56 7/32" (1.43 m)

ASSEMBLY PROCEDURES

UNDERCARRIAGE ASSEMBLY

f/ 80', 90' & 100' MODELS (con't.)

Attach Undercarriage to Conveyor



WARNING! Keep hands, legs and other body parts out from under the conveyor when it is being raised by the hoist or by other means.



Do Not rely solely on hydraulic or mechanical jacks and/or overhead hoist to support the conveyor. Always use jack stands, saw horses or equivalent for support.



WARNING! The slide-and-pulley assembly will be able to roll freely once it has been installed.



To avoid injury, it is recommended to strap the assembly to the upper undercarriage stop to prevent it from rolling during the remainder of the assembly process.

1. Raise the conveyor just high enough to position it over the undercarriage assembly (Do Not raise conveyor by the extreme ends of either the discharge or the inlet end).
2. Attach the lower undercarriage arms to the undercarriage mount as shown on Page 71. Secure each arm using four (4) 5/8" x 2" bolts, lock washers and non-lock nuts.
3. Install the upper slide and pulley assembly. Position the slide and pulley assembly sideways between the tracks near the upper undercarriage stop welded to the tracks.

Rotate the slide-and-pulley assembly to install. Make sure the pulleys are facing towards the inlet end of the conveyor (the slide plate on top of the pulley assembly will be positioned on top of the tracks, the rollers on the slide shaft will be on the bottom side of the tracks, See Page 71).

4. Position the upper undercarriage arms near the pulley assembly strapped to the upper undercarriage stop.

Secure each arm using four (4) 5/8" x 2" bolts, lock washers and non-lock nuts. Remove strap from upper stop and pulley assembly.

If the arms cannot be attached because of the strapping material, carefully remove the strap (the pulley assembly will be able to roll freely, be aware of the pinch point areas). Secure each arm using the 5/8" x 2" bolts, lock washers and non-lock nuts.

ASSEMBLY PROCEDURES

UNDERCARRIAGE ASSEMBLY
f/ 80', 90' & 100' MODELS (con't.)

**Undercarriage Attachment
to Conveyor**
80', 90' & 100' Models

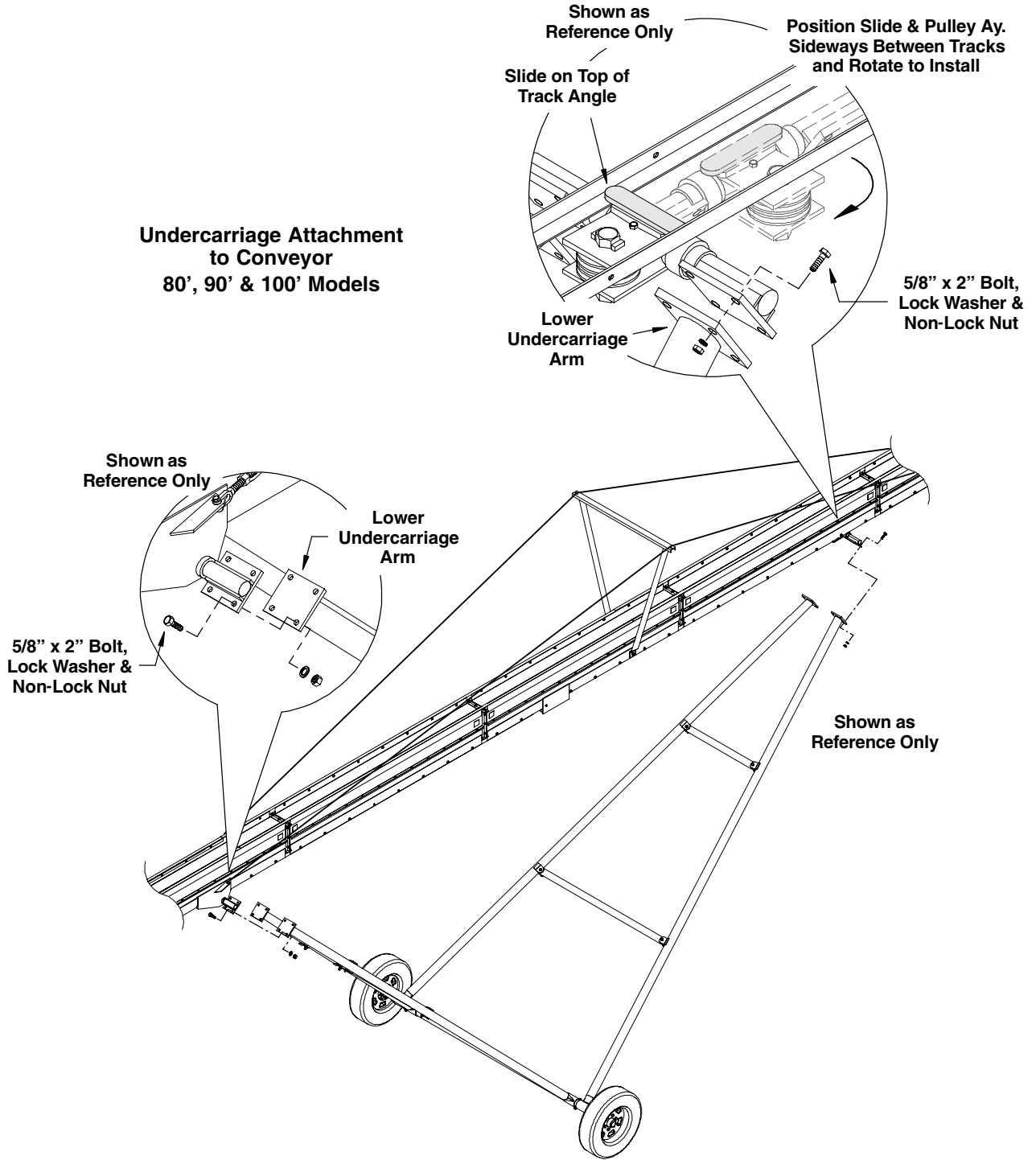



ASSEMBLY PROCEDURES

HYDRAULIC WINCH MOUNT

f/ 70', 80', 90' & 100' MODELS

 **WARNING!** Do Not use hands to guide the cable onto the winch drum during winch operation.

 When raising or lowering the conveyor, be aware and avoid overhead obstructions and electrical power lines. Watch cable to see that it is properly winding onto the winch drum.

 Never fully extend the cable, always keep three (3) complete wraps of cable around the winch drum.

 Keep all guards and shields in place. Do Not operate winch with kinked or damaged cable.

 Do Not continue to raise conveyor after undercarriage trolley reaches track stop. Shut off and lock out power source to adjust, service or clean.

The hydraulic winch will operate in either direction. This depends on which port is connected to pressure. If the drum should rotate in the opposite direction desired, simply reverse the hydraulic hoses on the relief valve.

Note: The direction of drum rotation should be so the cable wraps around the drum in the same direction as it was attached to the drum.

IMPORTANT! Although the winch has been shipped with oil already installed, it is recommended to check oil level before operation.

See Page 22 in the Lubrication and Maintenance Section of this manual for proper filling procedures.

1. After oil has been added, position the winch below the winch mount plate and secure to mount using four (4) 1/2" x 1 3/4" bolts, lock washers and non-lock nuts (See illustration on Page 73).
2. Locate the 3/8" dia. lift cable (see the following chart for cable lengths) and attach cable to winch drum. Make three (3) wraps of cable around the winch drum, then insert the end of the cable into one of the larger holes on the drum (it may be necessary to loosen the setscrew to allow the cable to slide through the opening, See Fig. 33).

Tighten the setscrew to secure end of cable to winch drum. Keep a bit of tension on the cable to help it stay wrapped around the drum.

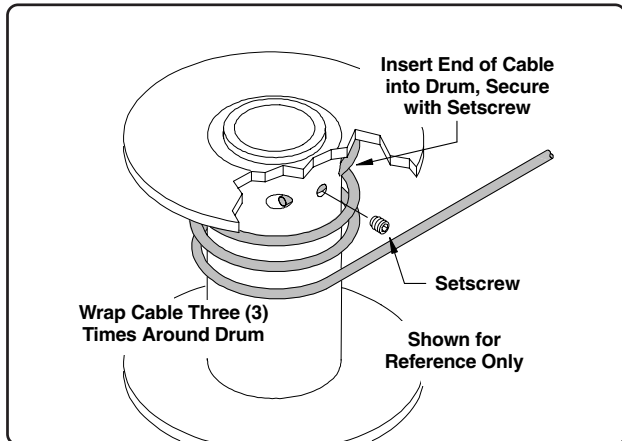

Fig. 33

3. Route the other end of the cable up and around the bottom pulley on the slide and pulley assembly.

Bring the cable back down and around the lower pulley as shown in the illustration on Page 73.

Route the cable back up and around the top pulley on the slide and pulley assembly.

Bring the cable back down and secure it to the anchor next to the lower pulley. Secure the cable using three (3) 3/8" cable clamps making sure the u-bolt portion of the clamp is against the loose end of the cable (See illustration on Page 73).

Cable routing and winch mounting will be the same for the 70', 80', 90' and 100' Models.

Cable Lengths:

- 70' Models - 3/8" dia. x 110' long
(10 mm x 33.53 m)
- 80' Models - 3/8" dia. x 122' long
(10 mm x 37.19 m)
- 90' Models - 3/8" dia. x 143' long
(10 mm x 43.59 m)
- 100' Models - 3/8" dia. x 160' long
(10 mm x 48.77 m)

Refer to Pages 76 and 77 for the hydraulic winch installation on the 40', 50', 60' & 65' Models.

HYDRAULIC WINCH MOUNT
f/ 70', 80', 90' & 100' Models (con't.)

Winch Mount & Cable Routing
for 70', 80' 90' & 100' Models

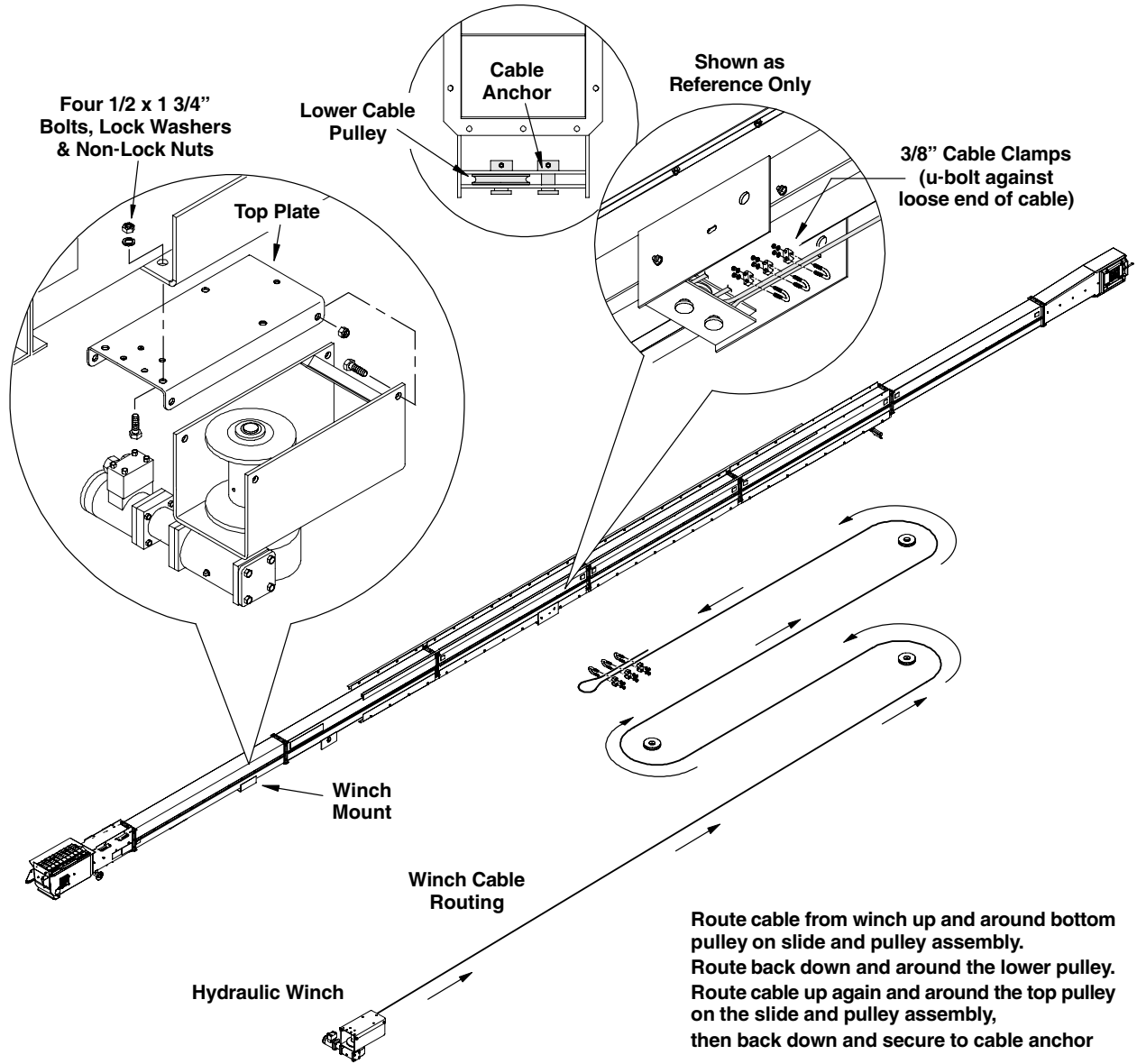



ASSEMBLY PROCEDURES

HYDRAULIC HOSE INSTALLATION

40', 50', 60', 65', 70',

80', 90' & 100' MODELS

 **WARNING!** Hydraulic systems are highly pressurized. Do Not connect or disconnect hydraulic components when there is pressure within the system.

 Escaping hydraulic oil, even an invisible pin hole leak can penetrate body tissues and cause serious injury.

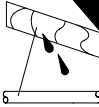
 Use a piece of wood or cardboard when searching for leaks, Never use your hands or other parts of your body.

 If injured by hydraulic oil escaping under pressure, see a doctor immediately. Serious infection or reaction can occur if medical attention is not received at once.

IMPORTANT! Keep hydraulic hoses away from moving parts. Allow hoses to coil in their original shape. Avoid pinching or twisting the hoses that would otherwise restrict the flow of hydraulic oil.

NOTE: The fittings used to connect the hoses to the tractor are not furnished, obtain these fittings locally. The fittings need to connect to a 1/2" NPT male hose end.

1. Apply a thin coat of clean oil to the o-rings on the 90° hose fittings and attach the hoses to the relief valve on the winch (See Fig. 34).

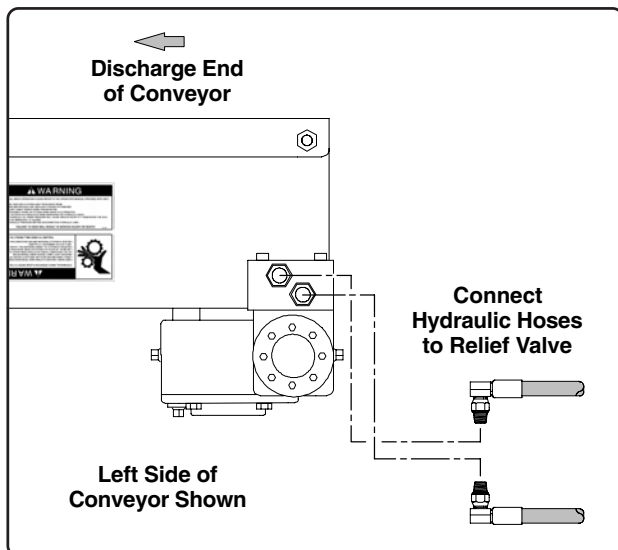

Fig. 34

2. Route the hoses under the conveyor housing, to the right side of the conveyor and towards the inlet end. Using the existing hardware and the clamps provided in the bolt kit, clamp the hoses to the lip of the housing as shown on Page 75 (the clamps can be spaced about every fourth bolt).
3. At the inlet end of the conveyor, remove the lower left nut from the flanged bearing on the inlet boot section (See illustration on Page 75).
4. Locate the "L-shaped" hose clamp from the parts kit (See Page 75). Position the hoses behind the clamp and secure clamp to the bearing bolt from which the nut was previously removed. Reinstall the nut.
5. After the hoses have been properly secured, it is good practice to always keep the excess length of hoses attached to the conveyor when conveyor is not in operation. This will help prevent damage to the hoses during storage and during transport.

The fittings on the hose ends should also remain covered when not in use, this not only helps to keep dirt and other contaminants from collecting in the fittings, but helps protect the threaded portion of the fittings as well.

HYDRAULIC HOSE INSTALLATION

40', 50', 60', 65', 70', 80', 90' & 100' MODELS (con't.)

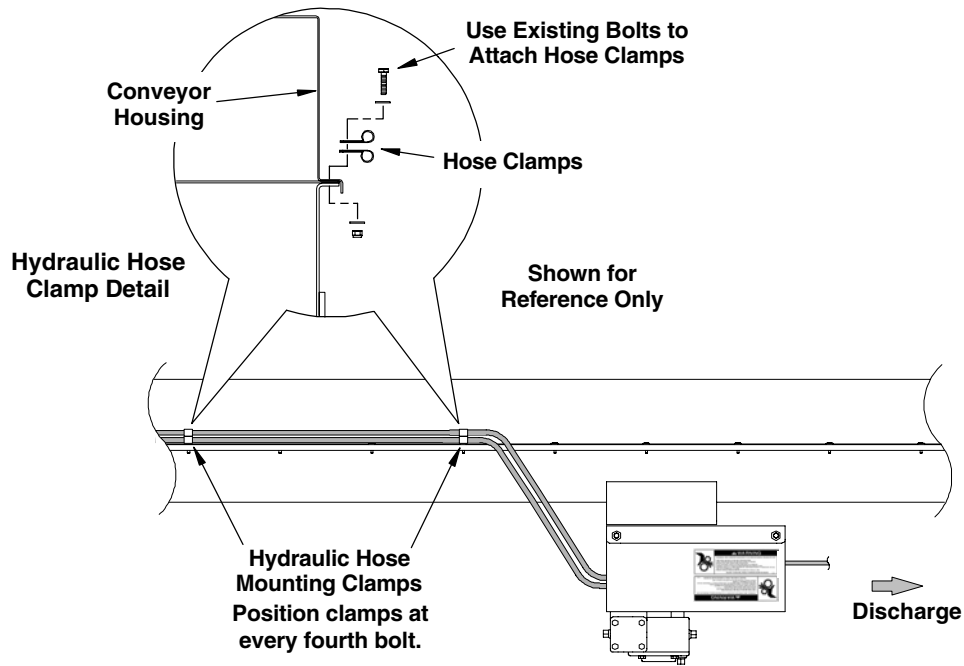



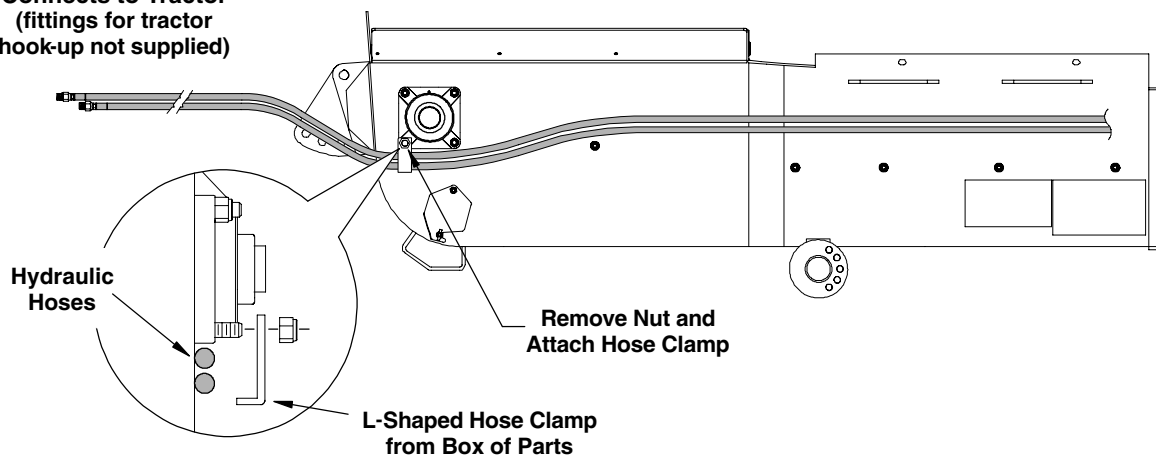



Connects to Tractor
(fittings for tractor
hook-up not supplied)



ASSEMBLY PROCEDURES

ELECTRIC & HYDRAULIC WINCH MOUNT 40', 50', 60', & 65' Models

	<p>WARNING! Do Not use hands to guide the cable onto the winch drum during winch operation.</p> <p>When raising or lowering the conveyor, be aware and avoid overhead obstructions and electrical power lines.</p>
	<p>Watch cable to see that it is properly winding onto the winch drum.</p> <p>Never fully extend the cable, always keep three (3) complete wraps of cable around the winch drum.</p>
	<p>Keep all guards and shields in place.</p> <p>Do Not operate winch with kinked or damaged cable.</p>
	<p>Do Not continue to raise conveyor after undercarriage trolley reaches track stop.</p> <p>Shut off and lock out power source to adjust, service or clean.</p>
	<p>A main power disconnect switch capable of being locked in only the "Off" position shall be used. This shall be locked whenever work is being done to the equipment.</p>
	<p>Hydraulic systems are highly pressurized. Do Not connect or disconnect hydraulic components when there is pressure in the system.</p>

Both the electric and hydraulic winch will mount in the same location and in the same manner on each respective model.

Electric Winch General Information

The electric winch for the 40', 50' 60' & 65' models requires a **dedicated 110 volt, 20 AMP system. Also any power cord over 25' (7.62 m) must be a 10-3 wire. 12-3 is okay for cords less than 25' (7.62 m).**

Electric motors and controls shall be installed by a qualified electrician and must meet the standards set by the National Electric Code and all local and state codes.

Hydraulic Winch General Information

The hydraulic winch will operate in either direction. This depends on which port is connected to the pressure. If the drum rotates in the opposite direction desired, simply reverse the hydraulic hoses on the relief valve.

Electric & Hydraulic Winch Installation

IMPORTANT! Although the electric and hydraulic winches are to have been shipped with oil already installed, it is recommended to check the oil level before operation.

The small electric winch is shipped with a universal mounting plate attached to the top winch plate. This plate can be removed if desired. The winch will still be able to be properly installed without this plate.

1. Remove and retain the four bolts securing the top plate to the winch frame.

Position the top plate below the winch mount plate and secure to mount using four (4) 1/2" x 1 3/4" bolts, lock washers and non-lock nuts (make sure top plate is oriented correctly so the winch faces the discharge end as shown in the illustration on the following page (Page 77).

Reattach the winch to the top plate using the four bolts previously removed (make sure the guide pin is inserted into the winch drum).

2. Locate the 1/4" dia. (6.5 mm) cable and attach cable to winch drum.

Make three (3) wraps of cable around the winch drum, then insert the end of the cable into one of the larger holes on the drum (it may be necessary to loosen the setscrew to allow the cable to slide through the opening, See Fig. 35).

3. Tighten the setscrew to secure end of cable to winch drum. Keep a bit of tension on the cable to help it stay wrapped around the drum.

Note: The direction of drum rotation should be so the cable wraps around the drum in the same direction as it was attached to the drum.

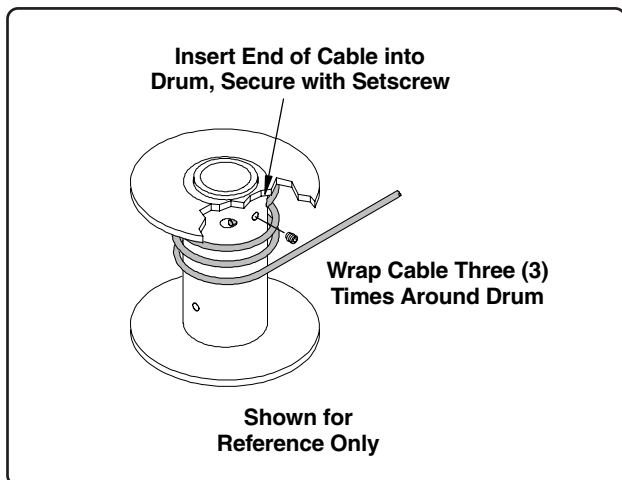

Fig. 35

ELECTRIC & HYDRAULIC WINCH MOUNT **40', 50', 60' & 65' MODELS (con't.)**

Route Lift Cable

1. Keep the cable taut and route it up and around the pulley on the trolley assembly (pass the cable between the pulley and cotter pin).

Route the cable back down and around the lower pulley (keep the cable taut to help prevent it from unraveling off the winch drum, and pass it between the pulley and cotter pin).

Route the cable back up and secure it to the trolley shaft as shown in the illustration below. Secure the cable using two 1/4" cable clamps (make sure the u-bolt portion of the clamp is against the loose end of the cable).

Hydraulic Hose Connection

For units using the hydraulic winch, refer to Pages 74 and 75 for procedures on routing and connecting the hydraulic hoses.

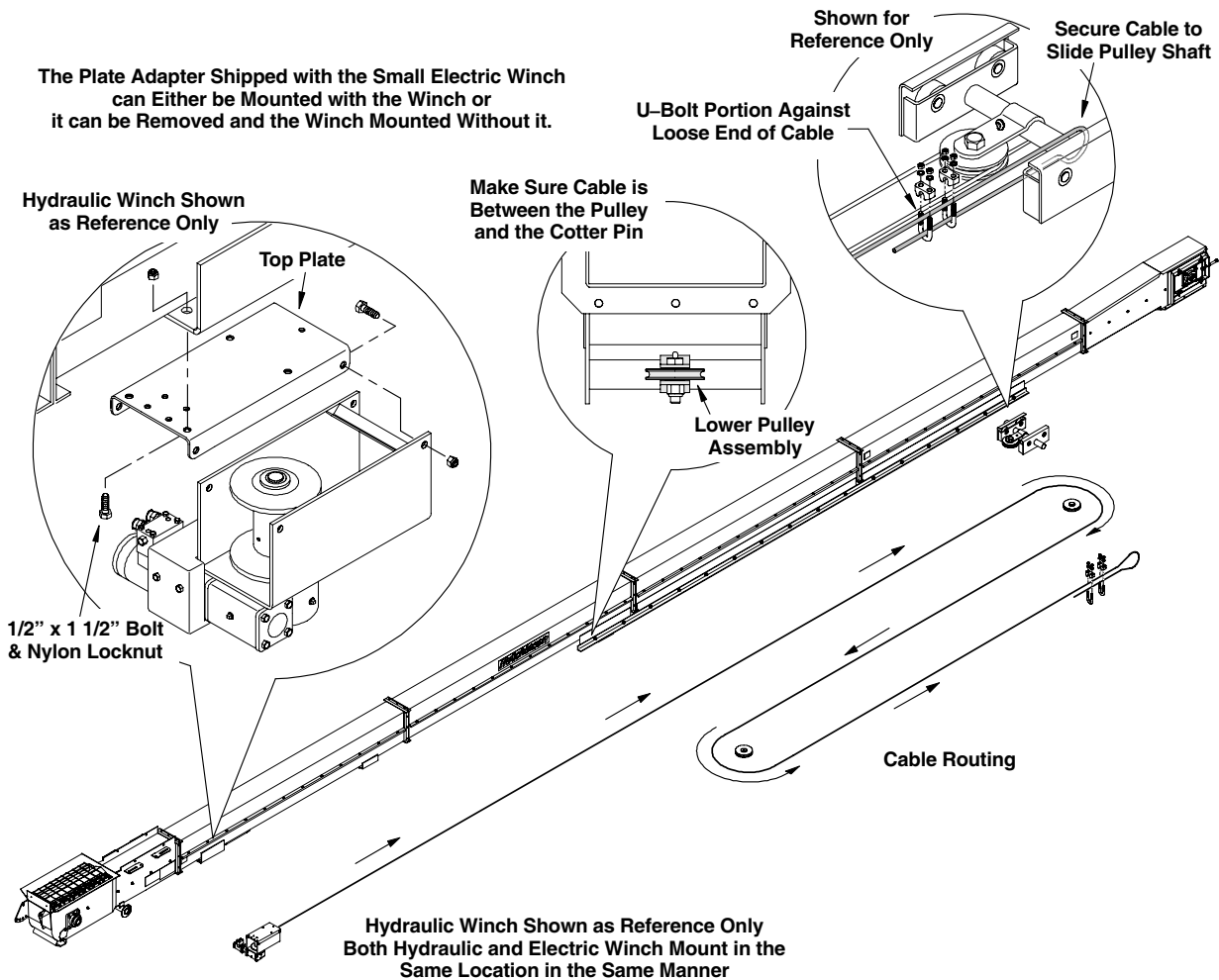

Cable Lengths:

- 40' Models - 1/4" dia. x 51' long (6.5 mm x 15.54 m)
- 50' Models - 1/4" dia. x 70' long (6.5 mm x 21.34 m)
- 60' Models - 1/4" dia. x 82' long (6.5 mm x 24.99 m)
- 65' Models - 1/4" dia. x 93' long (6.5 mm x 28.35 m)

ASSEMBLY PROCEDURES

ELECTRIC WINCH OPERATION

40', 50', 60' & 65' MODELS



WARNING! Shut off power and lockout power source before attempting to adjust, service, clean or repair the winch or any of its components.

Electric motors and controls shall be installed by a qualified electrician and must meet the standards set by the National Electric Code and all local and state codes.

IMPORTANT! The optional 1006526 Winch requires a dedicated 110V, 20 AMP circuit. Also any power cord over 25' (7.62 m) must be a 10-3 wire. 12-3 is okay for cords less than 25' (7.62 m).

A main power disconnect switch capable of being locked in only the "Off" position shall be used. This shall be locked whenever work is being done to the equipment and components.

The pendant control is used to operate the upward and downward motions of the conveyor by depressing either of the buttons labeled "Forward" or "Reverse" on the hand-held pendant.

IMPORTANT! Do Not continuously press buttons back and forth in quick succession, pause at least two seconds before changing winch direction.

Keep pendant cord away from moving parts. To prevent damage to the pendant, store pendant and its cord on provided hangers when not in use. Make sure they are properly secured during transport.

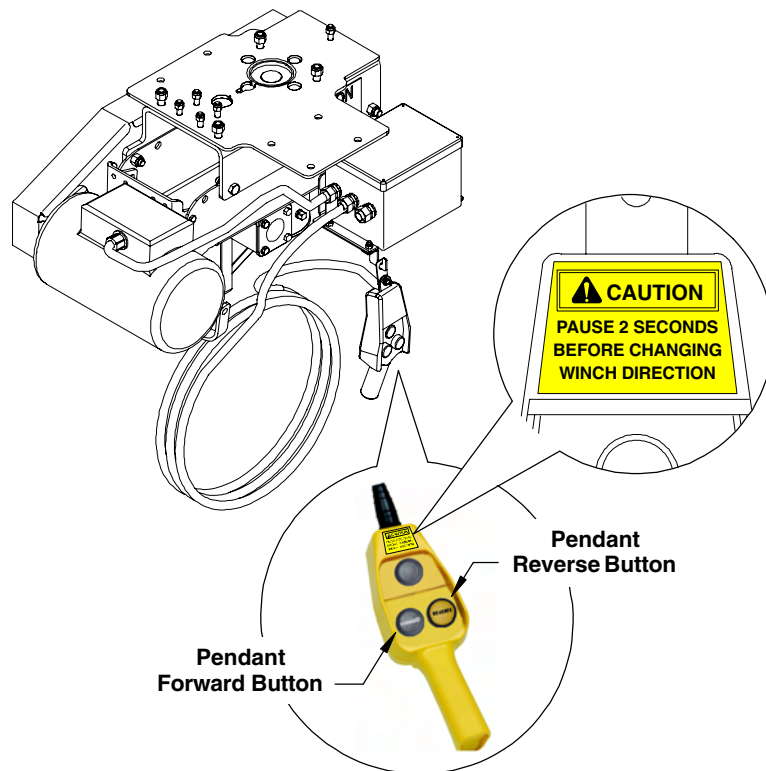

ELECTRIC WINCH MOUNT **70', 80', 90' & 100' MODELS**



WARNING! Do Not use hands to guide the cable onto the winch drum during winch operation.



When raising or lowering the conveyor, be aware and avoid overhead obstructions and electrical power lines. Never fully extend the cable, always keep three (3) complete wraps of cable around the winch drum.



Keep all guards and shields in place. Do Not operate winch with kinked or damaged cable.



Watch cable to see that it is properly winding onto the winch drum.



Do Not continue to raise conveyor after undercarriage trolley reaches track stop.



A main power disconnect switch capable of being locked in only the "Off" position shall be used. This shall be locked whenever work is being done to the equipment. Shut off and lock out power source to adjust, service or clean.

The winch is designed to be connected to a **220 volt electrical power system**.

Electric motors and controls shall be installed by a qualified electrician and must meet the standards set by the National Electric Code and all local and state codes.

IMPORTANT! Although the winch has been shipped with oil already installed, it is recommended to check oil level before operation. Before conveyor operation you must remove the plug from the top of the gearbox and install the vent/fill plug (See Fig. 36).

For future oil level checks and/or adding oil to the winch gearbox, refer to the **Lubrication & Maintenance Section** in this manual.

1. Position the winch below the winch mount plate and secure to mount using six (6) 1/2" x 1 3/4" bolts, lock washers and non-lock nuts (See Fig. 36).
2. Locate the 3/8" dia. x 110' long* (10 mm x 33.53 m) cable (this cable length is for the 70' Models, see the following chart for other model lengths).

Attach cable to winch drum. Make three (3) wraps of cable around the winch drum, then insert the end of the cable into one of the larger holes on the drum (it may be necessary to loosen the setscrew to allow the cable to slide through the opening, See Fig. 37).

3. Tighten the setscrew to secure end of cable to winch drum. Keep a bit of tension on the cable to help it stay wrapped around the drum.

Note: The direction of drum rotation should be so the cable wraps around the drum in the same direction as it was attached to the drum.

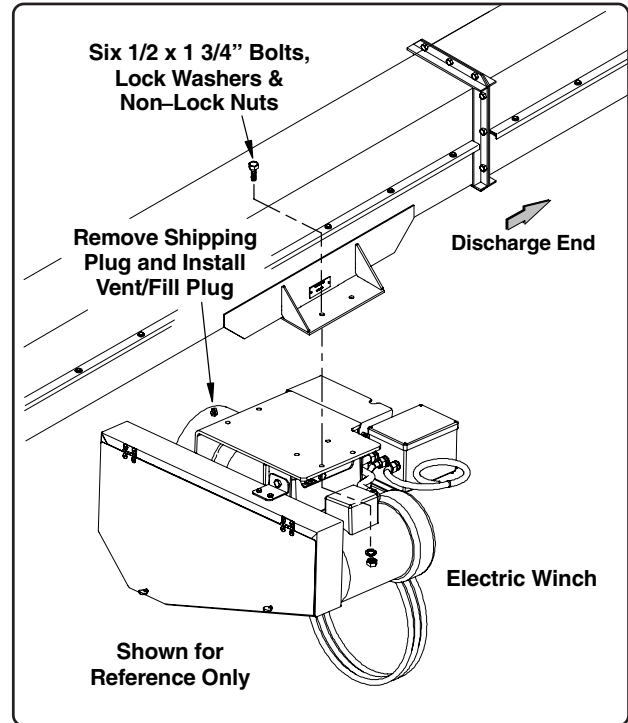

Fig. 36

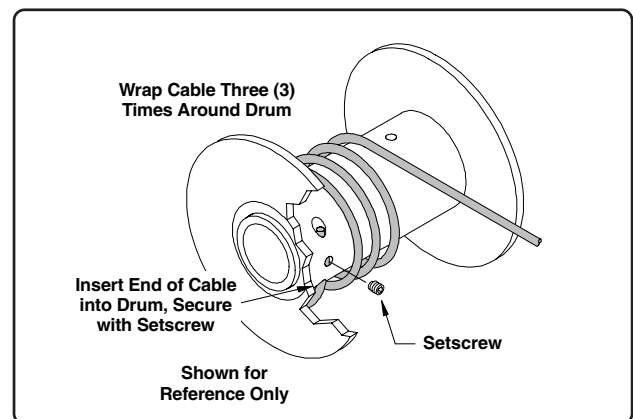

Fig. 37

***Cable Lengths:**

- 70' Models - 3/8" dia. x 110' long (10 mm x 33.53 m)
- 80' Models - 3/8" dia. x 122' long (10 mm x 37.19 m)
- 90' Models - 3/8" dia. x 143' long (10 mm x 43.59 m)
- 100' Models - 3/8" dia. x 160' long (10 mm x 48.77 m)

ASSEMBLY PROCEDURES

ELECTRIC WINCH MOUNT

70', 80', 90' & 100' MODELS (con't.)

4. Route the other end of the cable up and around the bottom pulley on the slide and pulley assembly. Bring the cable back down and around the lower pulley as shown in the illustration below. Route the cable back up and around the top pulley on the slide and pulley assembly. Bring the cable back down and secure it to the anchor next to the lower pulley. Secure the cable using three (3) 3/8" cable clamps making sure the u-bolt portion of the clamp is against the loose end of the cable (See illustration below). Cable routing will be the same for the 70', 80', 90' and 100' Models.

**70' Model Shown as Reference Only,
Cable Routing will be the Same for the
80', 90' & 100' Models**

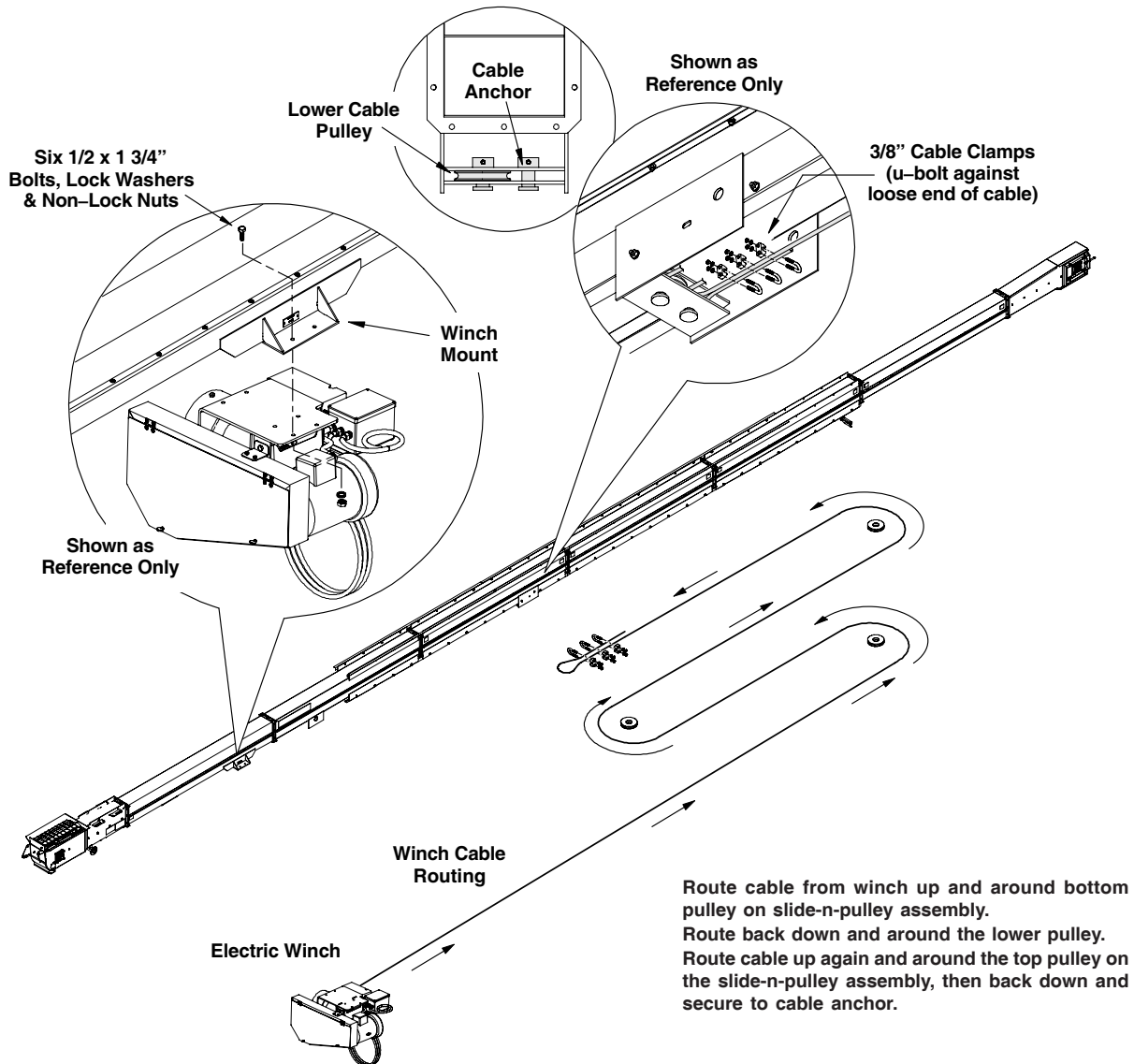

ELECTRIC WINCH OPERATION

70', 80', 90' & 100' MODELS



WARNING! Shut off power and lockout power source before attempting to adjust, service, clean or repair the winch or any of its components.

Electric motors and controls shall be installed by a qualified electrician and must meet the standards set by the National Electric Code and all local and state codes.

A main power disconnect switch capable of being locked in only the "Off" position shall be used. This shall be locked whenever work is being done to the equipment and components.

The pendant control is used to operate the upward and downward motions of the conveyor by depressing either of the buttons labeled "Forward" or "Reverse" on the hand-held pendant.

IMPORTANT! Do Not continuously press buttons back and forth in quick succession, pause at least two seconds before changing winch direction.

Keep pendant cord away from moving parts. To prevent damage to the pendant, store pendant and its cord on provided hangers when not in use. Make sure they are properly secured during transport.

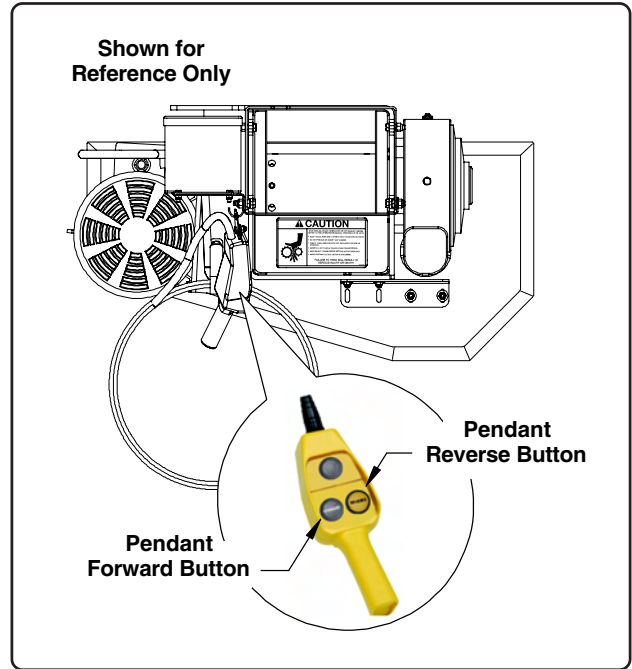
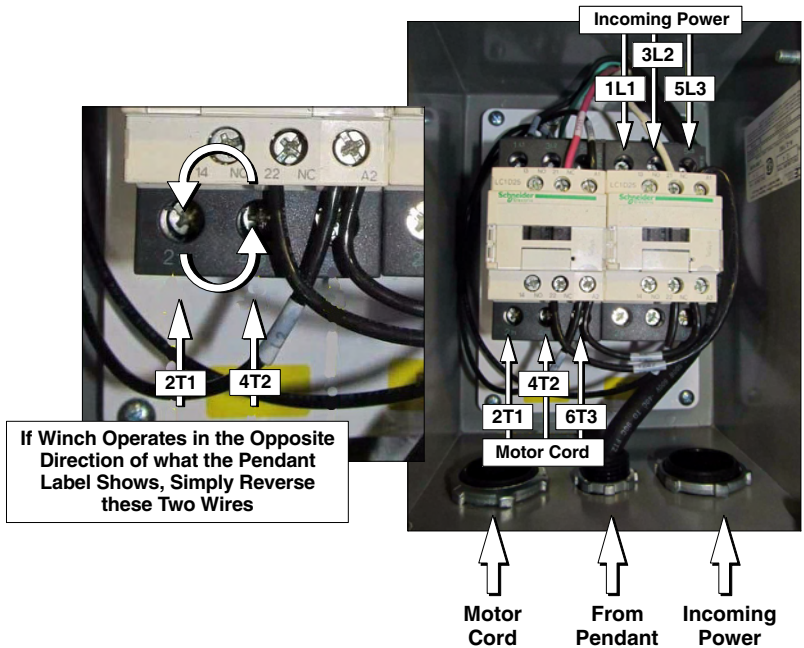
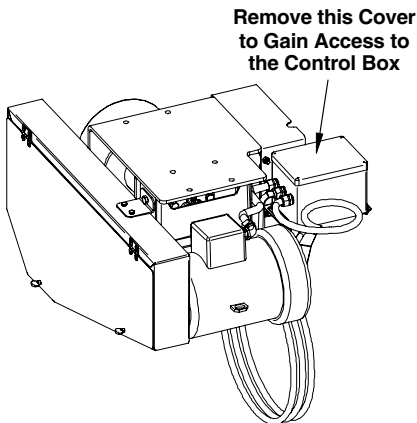

Fig. 38



PARTS LIST TABLE OF CONTENTS

<i>Safety Decals</i>	<i>P-1</i>
<i>Boot, Tracks and Trunk Sections (40', 50' & 60' Models)</i>	<i>P-2</i>
<i>Boot, Tracks and Trunk Sections (65' & 70' Models)</i>	<i>P-3</i>
<i>Boot Components (40', 50', 60', 65' & 70' Models)</i>	<i>P-4</i>
<i>Hitch Assembly (40', 50', 60', 65', 70', 80', 90' & 100' Models)</i>	<i>P-5</i>
<i>Boot, Tracks and Trunk Sections (80', 90' & 100' Models)</i>	<i>P-5 to P-7</i>
<i>Boot Components (80', 90' & 100' Models)</i>	<i>P-8</i>
<i>Hopper Components (40', 50', 60', 65', 70', 80', 90' & 100' Models)</i>	<i>P-9</i>
<i>Truss Components (70' Models)</i>	<i>P-9</i>
<i>Truss Components (80', 90' & 100' Models)</i>	<i>P-10 to P-12</i>
<i>Head Section Components (40', 50', 60', 65', 70', 80', 90' & 100' Models)</i>	<i>P-13</i>
<i>PTO Drive Components (40', 50', 60', 65', 70', 80', 90' & 100' Models)</i>	<i>P-14</i>
<i>PTO Housing Breakdown (40', 50', 60', 65' & 70' Models)</i>	<i>P-15</i>
<i>PTO Housing Breakdown (80', 90' & 100' Models)</i>	<i>P-16</i>
<i>Drop Leg Jack Components (40', 50', 60', 65', 70', 80', 90' & 100' Models)</i>	<i>P-17</i>
<i>Discharge Spouts (40', 50', 60', 65', 70', 80', 90' & 100' Models)</i>	<i>P-17</i>
<i>Electric Components (40', 50', 60', 65', 70', 80', 90' & 100' Models)</i>	<i>P-18 to P-19</i>
<i>Driveline Components (40', 50', 60', 65', 70', 80', 90' & 100' Models)</i>	<i>P-20</i>
<i>Hub Assembly (40', 50', 60', 65', 70', 80', 90' & 100' Models)</i>	<i>P-21</i>
<i>Winch, Undercarriage, Lift Cable (40', 50', 60' & 65' Models)</i>	<i>P-22 to P-23</i>
<i>Winch, Lift Cable & Slide-and-Pulley Assy. (70', 80', 90' & 100' Models)</i>	<i>P-24 to P-25</i>
<i>Undercarriage Components (70' Models)</i>	<i>P-26</i>
<i>Undercarriage Components (80', 90' & 100' Models)</i>	<i>P-27</i>
<i>Hydraulic Winch Components f/ 40', 50', 60', 65', 70', 80', 90' & 100' Models</i>	<i>P-28</i>
<i>Electric Winch Components f/ 40', 50', 60' & 65' Models</i>	<i>P-29</i>
<i>Electric Winch Components f/ 70', 80', 90' & 100' Models</i>	<i>P-30</i>
<i>Manual Winch Components</i>	<i>P-31</i>
<i>Chain and Paddle Assembly</i>	<i>P-32</i>
<i>Reduction Gearbox Breakdown, 4:1 Reducer, Part No. 1028204-1</i>	<i>P-32</i>

SAFETY DECALS & SIGNS

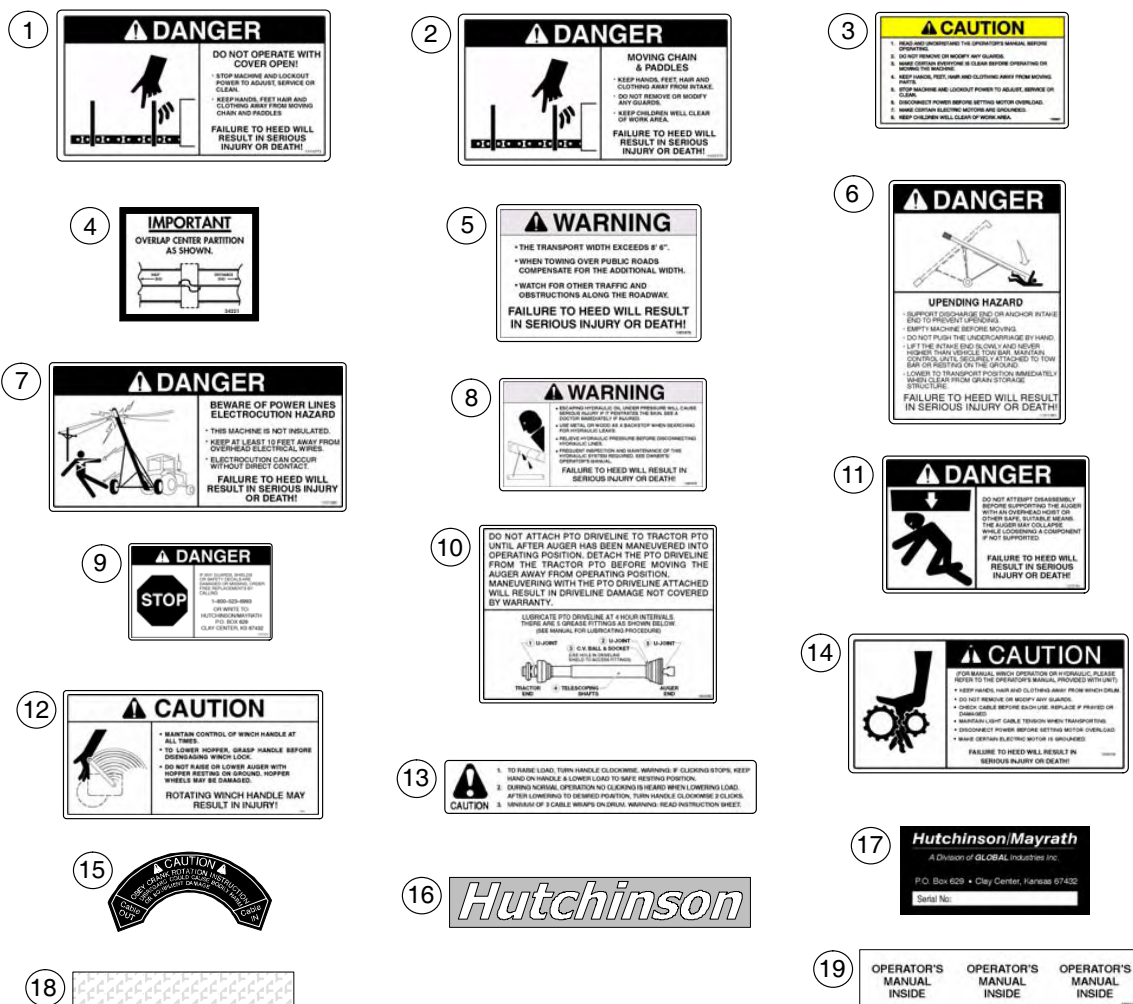

These are decals that may appear on your conveyor.
Not all decals will be on every model.

Ref. No.	Part No.	Description	Ref. No.	Part No.	Description
1	1012872	Danger Decal, Do Not Operate...	11	1001984	Danger Decal, Disassembly...
2	1002311	Danger Decal, Moving Chain...	12	1004460	Caution Decal, Winch Handle
3	1001973	Caution Decal, General Information	13	2169A1	Caution Decal, Winch Operation
4	34221	Decal, Trunk Alignment	14	1006559	Caution Decal, Winch Drum
5	1001975	Warning Decal, Transport Width	15	1002805	Caution Decal, Cable In & Out
6	1001981	Danger Decal, Upending...	16	1001125	Decal, Hutchinson
7	1001980	Danger Decal, Electrocutation...	17	34687	Serial No. Plate
8	1001974	Warning Decal, Hydraulic...	18	1021180	Decal, Yellow Reflective
9	1005324	Danger Decal, Missing Guards...	19	1004461	Decal, Operator's Manual
10	1013783	Decal, PTO Attachment			

PARTS LIST

BOOT, TRACK & TRUNK SECTIONS 40', 50' & 60' MODELS

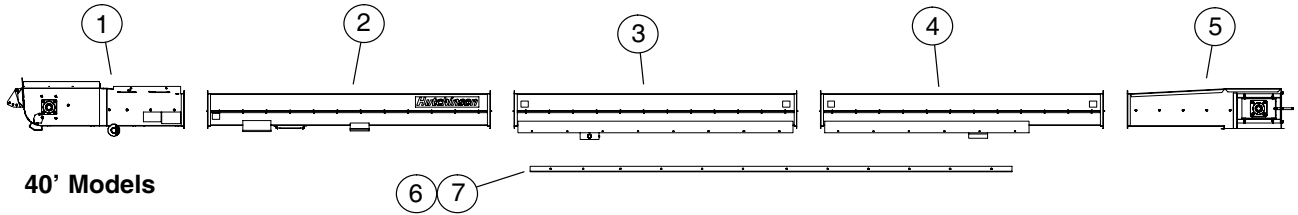

40' Models

Ref. No.	Part No.	Description	Ref. No.	Part No.	Description
1	1045068	Boot Assembly f/ 40' Models	5	1005748	Head Section
2	1005759	First Trunk Section	6	1004808	Track Section, Left, 210" (5.33 m)
3	1005758	Second Trunk Section	7	1004808	Track Section, Right, 210" (5.33 m)
4	1005757	Third Trunk Section			

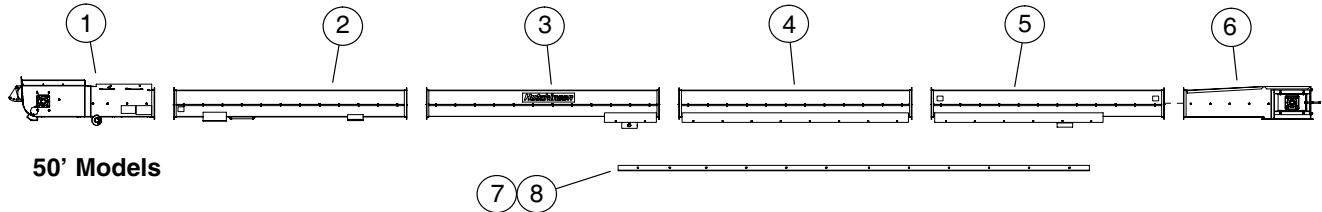

50' Models

Ref. No.	Part No.	Description	Ref. No.	Part No.	Description
1	1045068	Boot Assembly f/ 50' Models	5	1005760	Fourth Trunk Section
2	1005763	First Trunk Section	6	1005748	Head Section
3	1005762	Second Trunk Section	7	552849	Track Section, Left, 240" (6.10 m)
4	1005761	Third Trunk Section	8	552849	Track Section, Right, 240" (6.10 m)

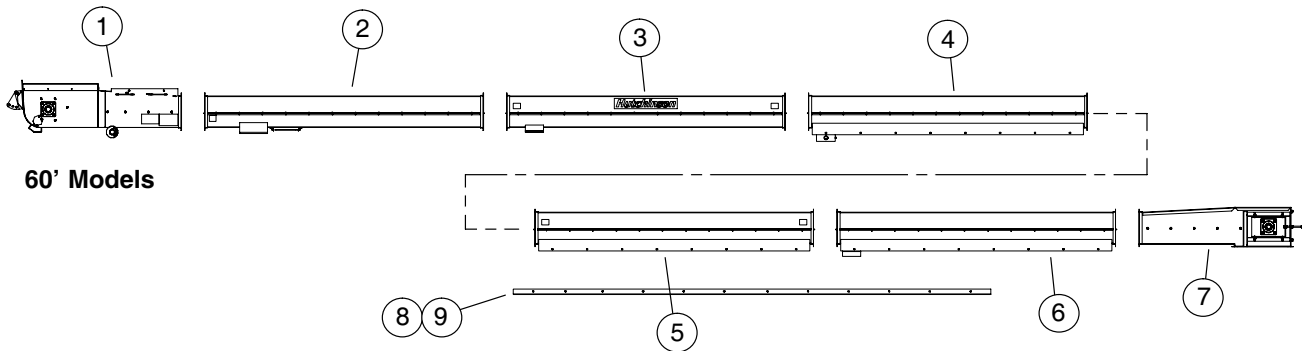

60' Models

Ref. No.	Part No.	Description	Ref. No.	Part No.	Description
1	1045068	Boot Assembly f/ 60' Models	6	1005764	Fifth Trunk Section
2	1005767	First Trunk Section	7	1005748	Head Section
3	1005766	Second Trunk Section	8	631103	Track Section, Left, 300" (7.62 m)
4	1005765	Third Trunk Section	9	552849	Track Section, Right, 300" (7.62 m)
5	1005761	Fourth Trunk Section			

PARTS LIST

BOOT, TRACK & TRUNK SECTIONS 65' & 70' MODELS

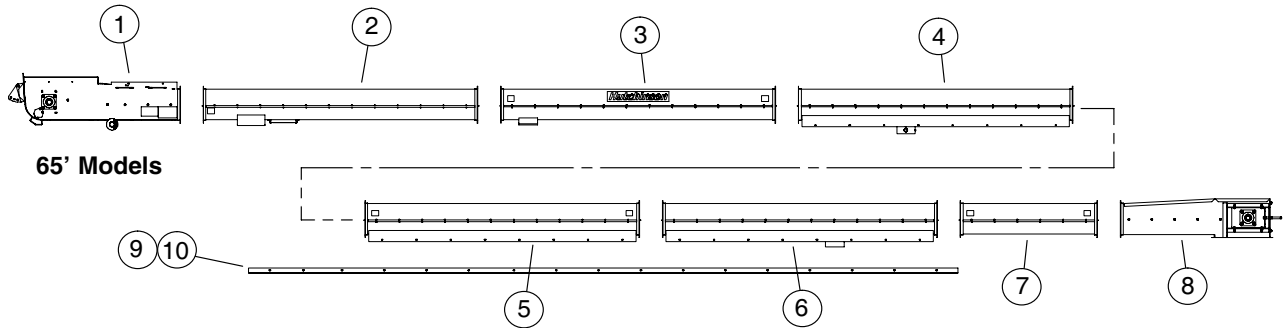

Ref. No.	Part No.	Description	Ref. No.	Part No.	Description
1	1045068	Boot Assembly f/ 65' Models	6	1005768	Fifth Trunk Section
2	1005767	First Trunk Section	7	631335	Sixth Trunk Section
3	1005766	Second Trunk Section	8	1005748	Head Section
4	1005769	Third Trunk Section	9	631104	Track Section, Left, 360" (9.14 m)
5	1005761	Fourth Trunk Section	10	631104	Track Section, Right, 360" (9.14 m)

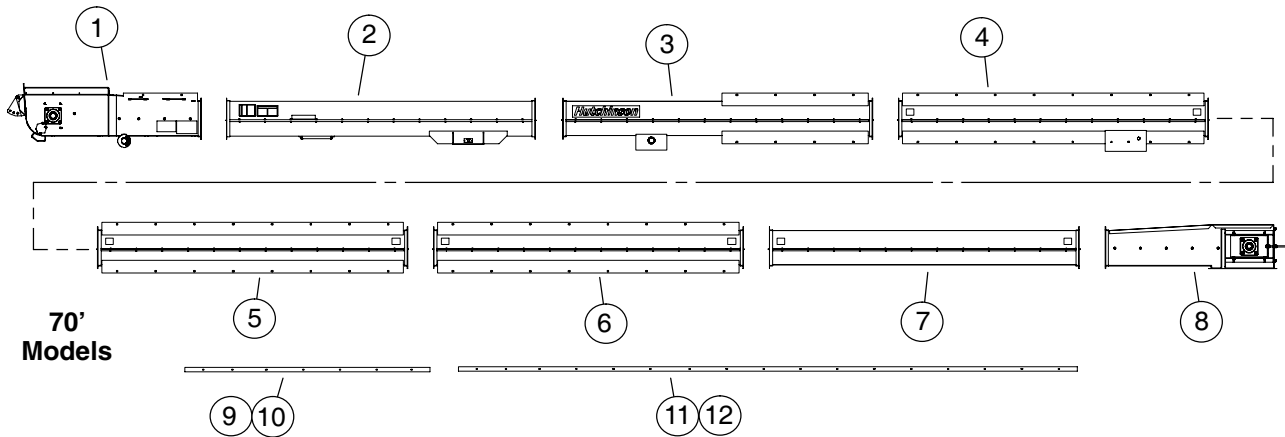

Ref. No.	Part No.	Description	Ref. No.	Part No.	Description
1	1045068	Boot Assembly f/ 70' Models	7	631337	Sixth Trunk Section
2	1007213	First Trunk Section	8	1005748	Head Section
3	1005772	Second Trunk Section	9	552916	Lower Track, Left, 120" (3.05 m)
4	1005771	Third Trunk Section	10	552916	Lower Track, Right, 120" (3.05 m)
5	1005770	Fourth Trunk Section	11	631131	Upper Track, Left, 300" (7.62 m)
6	1005770	Fifth Trunk Section	12	631131	Upper Track, Right, 300" (7.62 m)

PARTS LIST

BOOT ASSEMBLY

f/ 40', 50', 60', 65' & 70' MODELS

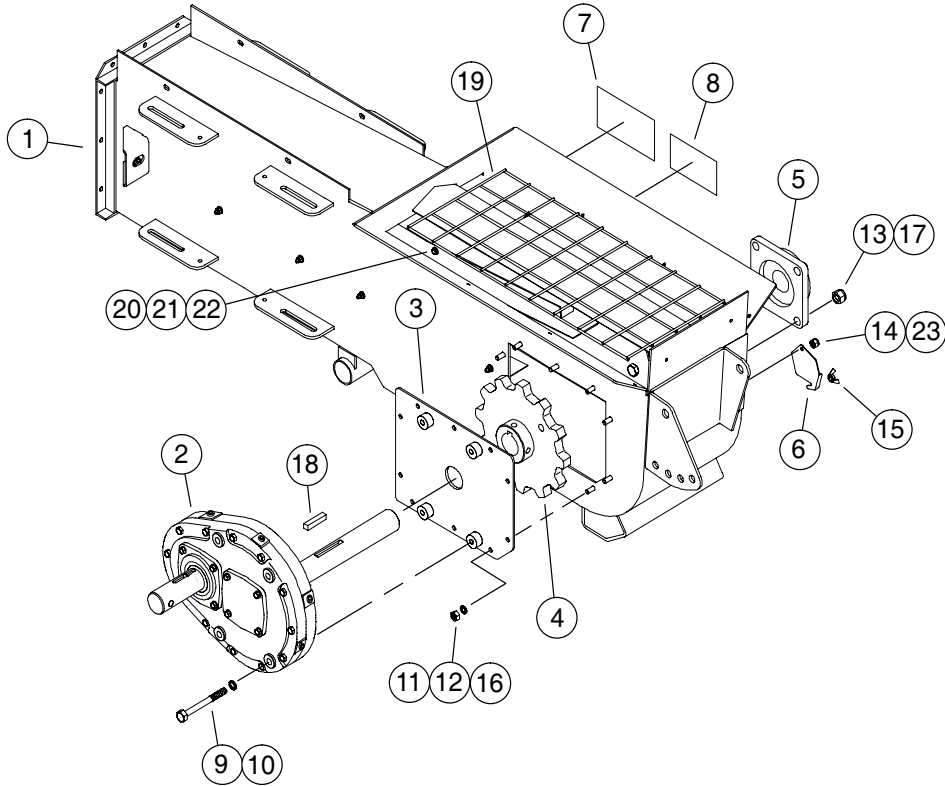

The complete boot assembly can be obtained: Order Part No. 1045068. The complete assembly includes all items referenced below

Ref. No.	Part No.	Description	Ref. No.	Part No.	Description
1	1044778	Boot Weldment f/ 40', 50' 60', 65' & 70' Models	12	D1150	Lock Washer, 3/8"
2	1028204-1	Gearbox, 4:1 reduction	13	33139	Nut, 5/8-11 Nylon Lock
3	1028250	Plate, Gear Cover	14	33135	Nut, 5/16-18 Nylon Lock
4	1005565	Sprocket, 12 T, 2" bore	15	33157	Wingnut, 5/16-18
5	2214C	Bearing, 4-hole flange	16	33060	Bolt, 3/8-16 x 1" G5
6	1004738	Door, Hopper Cleanout	17	33244	Bolt, 5/8-11 x 2" G5
7	1001973	Decal, Caution	18	4021L1	Key, 1/2" sq. x 2 3/4" lg
8	1002311	Decal, Danger, Moving Chain...	19	1028137	Screen Shield
9	33384	Bolt, 1/2-13 x 4 1/2" G5	20	33023	Washer, 5/16" Flat
10	D1143	Lock Washer, 1/2"	21	33144	Washer, 5/16" Lock
11	D1149	Nut, 3/8-16 Non-Lock	22	33046	Bolt, 5/16-18 x 1"
			23	4701-1	Bolt, 5/16-18 x 3/4"

PARTS LIST

HITCH ASSEMBLY

40', 50', 60', 65', 70', 80', 90' & 100' MODELS

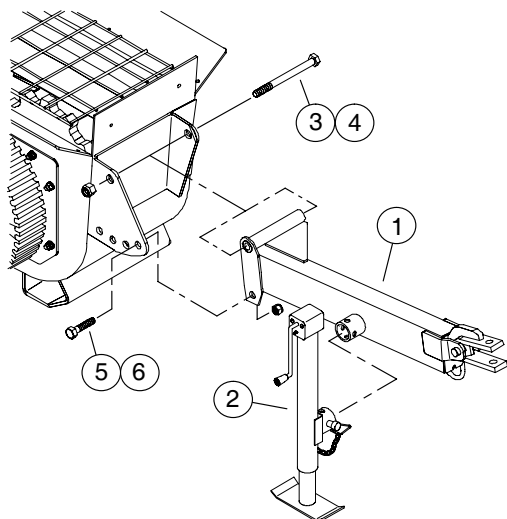

Ref. No.	Part No.	Description
1	1022696	Hitch Weldment (all models)
2	1024776	Screw Jack (15" travel)
3	835058	Bolt, 3/4-10 x 11" G5 PLT
4	33140	Nut, 3/4-10 Nylon Lock PLT
5	33276	Bolt, 5/8-11 x 1 1/2" G5 PLT
6	33139	Nut, 5/8-11 Nylon Lock PLT

BOOT, TRACK & TRUNK SECTIONS

80' MODELS

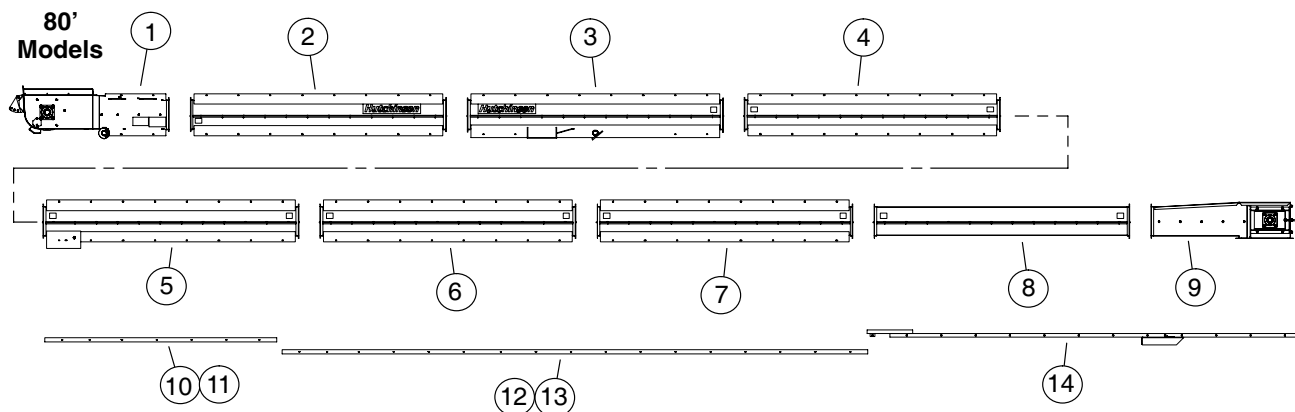

Ref. No.	Part No.	Description	Ref. No.	Part No.	Description
1	1045069	Boot Assembly f/ 80' Models	8	631337	Seventh Trunk Section
2	1005776	First Trunk Section	9	1005748	Head Section
3	1007214	Second Trunk Section	10	552754	Lower Track, Left, 90" (2.29 m)
4	1005770	Third Trunk Section	11	552754	Lower Track, Right, 90" (2.29 m)
5	1005774	Fourth Trunk Section	12	552711	Mid Track, Left, 240" (6.10 m)
6	1005770	Fifth Trunk Section	13	552711	Mid Track, Right, 240" (6.10 m)
7	1005770	Sixth Trunk Section	14	130116	Upper Track Weldment, 190" (4.83 m)

PARTS LIST

BOOT, TRACK & TRUNK SECTIONS

90' MODELS

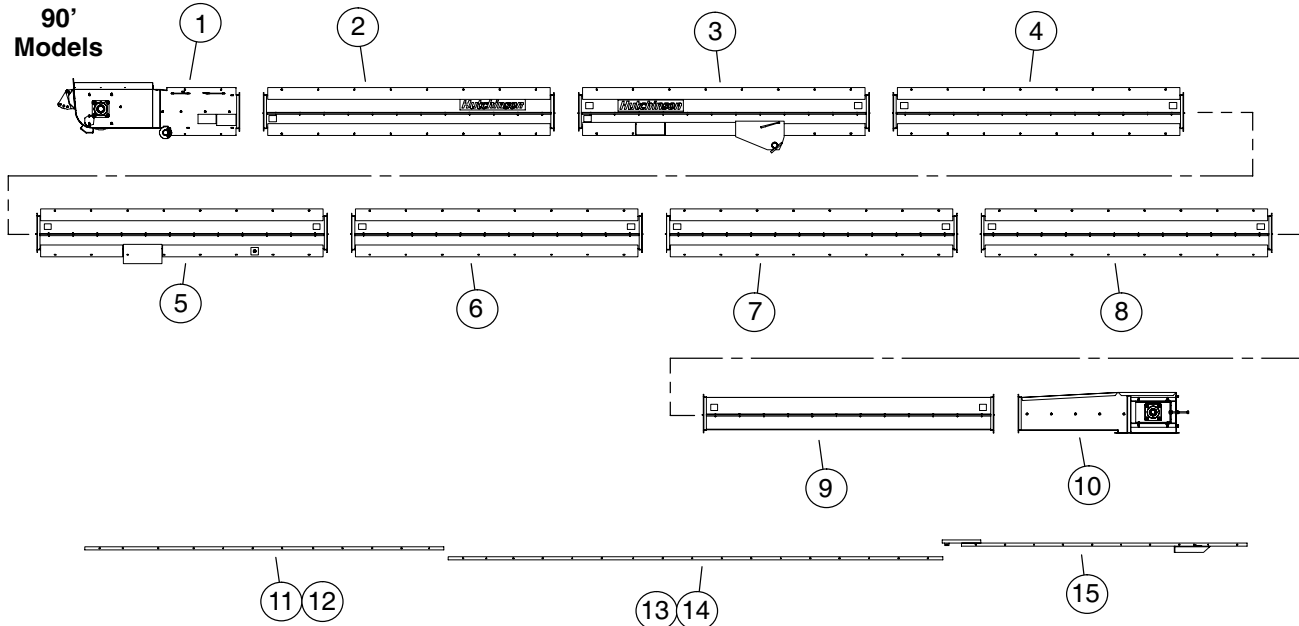

Ref. No.	Part No.	Description	Ref. No.	Part No.	Description
1	1045069	Boot Assembly f/ 80' Models	9	631337	Eighth Trunk Section
2	1005776	First Trunk Section	10	1005748	Head Section
3	1007215	Second Trunk Section	11	552713	Lower Track, Left, 180" (4.57 m)
4	1005770	Third Trunk Section	12	552713	Lower Track, Right, 180" (4.57 m)
5	1005777	Fourth Trunk Section	13	552711	Mid Track, Left, 240" (6.10 m)
6	1005770	Fifth Trunk Section	14	552711	Mid Track, Right, 240" (6.10 m)
7	1005770	Sixth Trunk Section	15	130117	Upper Track Weldment, 150" (3.81 m)
8	1005770	Seventh Trunk Section			

PARTS LIST

BOOT, TRACK & TRUNK SECTIONS

100' MODELS

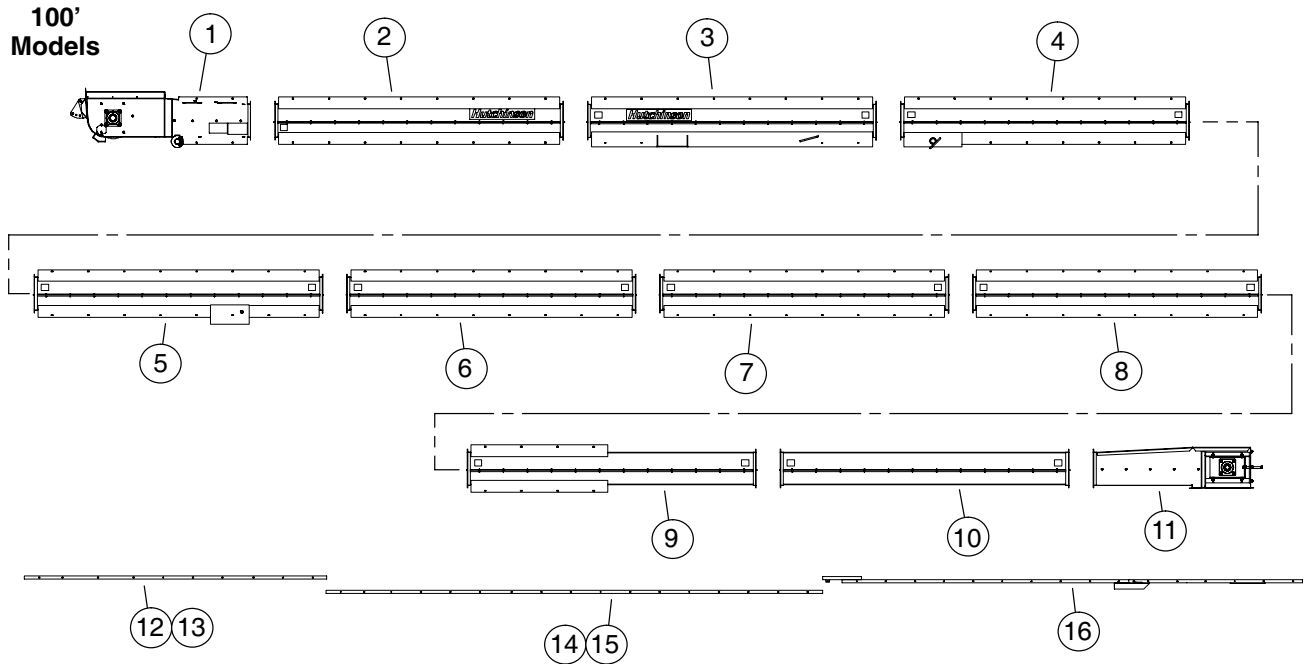

Ref. No.	Part No.	Description	Ref. No.	Part No.	Description
1	1045069	Boot Assembly f/ 80' Models	9	1005779	Eighth Trunk Section
2	1005776	First Trunk Section	10	631337	Ninth Trunk Section
3	1007216	Second Trunk Section	11	1005748	Head Section
4	1005781	Third Trunk Section	12	552824	Lower Track, Left, 150" (3.81 m)
5	1005780	Fourth Trunk Section	13	552824	Lower Track, Right, 150" (3.81 m)
6	1005770	Fifth Trunk Section	14	552711	Mid Track, Left, 240" (6.10 m)
7	1005770	Sixth Trunk Section	15	552711	Mid Track, Right, 240" (6.10 m)
8	1005770	Seventh Trunk Section	16	130138	Upper Track Weldment, 240" (6.10 m)

PARTS LIST

BOOT ASSEMBLY

f/ 80', 90' & 100' MODELS

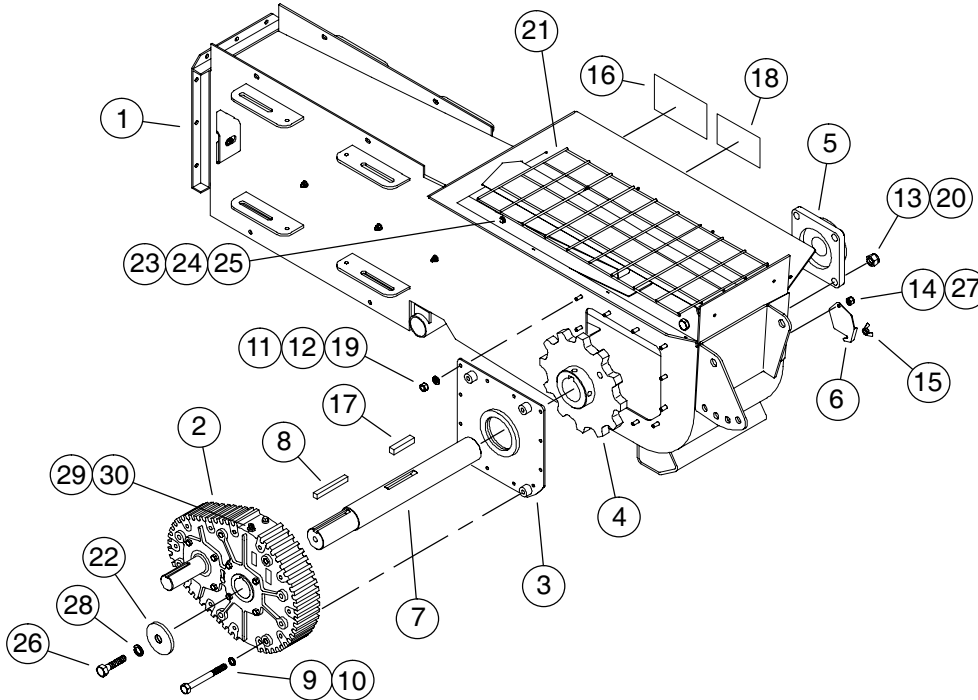

The complete boot assembly can be obtained: Order Part No. 1045069. The complete assembly includes all items referenced below

Ref. No.	Part No.	Description	Ref. No.	Part No.	Description
1	1044779	Boot Weldment f/ 80', 90' & 100' Models	16	1001973	Decal, Caution
2	1031082-1	Gearbox, 8100 4:1 reduction	17	1027214	Key, 5/8" sq. x 3" long
3	1032607	Plate, Gear Cover	18	1002311	Decal, Danger, Moving Chain...
4	1005564	Sprocket, 12 T, 2 7/16" bore	19	33060	Bolt, 3/8-16 x 1" G5
5	3090L1	Bearing, 4-hole flange	20	33244	Bolt, 5/8-11 x 2" G5
6	1004738	Door, Hopper Cleanout	21	1028137	Screen Shield
7	1031912	Shaft, Boot	22	1031922	Washer, 3 1/2" O.D. x 13/16" I.D.
8	1031921	Key, 5/8" sq. x 5 1/4" long	23	33046	Bolt, 5/16-18 x 1
9	1031908	Bolt, 1/2-13 x 4 1/2" G5	24	33023	Washer, 5/16" Flat
10	D1143	Lock Washer, 1/2"	25	33144	Washer, 5/16" Lock
11	D1149	Nut, 3/8-16 Non-Lock	26	33110	Bolt, 3/4-10 x 2"
12	D1150	Lock Washer, 3/8"	27	4701-1	Bolt, 5/16-18 x 3/4"
13	33139	Nut, 5/8-11 Nylon Lock	28	D1153	Washer, 3/4" Lock
14	33135	Nut, 5/16-18 Nylon Lock	29	1030211	Reducer Bushing, 3/8" to 1/8" NPT
15	33157	Wingnut, 5/16-18	30	1015290	Relief Vent, 1-5 PSI, 1/8-27 NPT

PARTS LIST

HOPPER COMPONENTS

f/ 40', 50', 60', 65', 70', 80',
90' & 100' MODELS

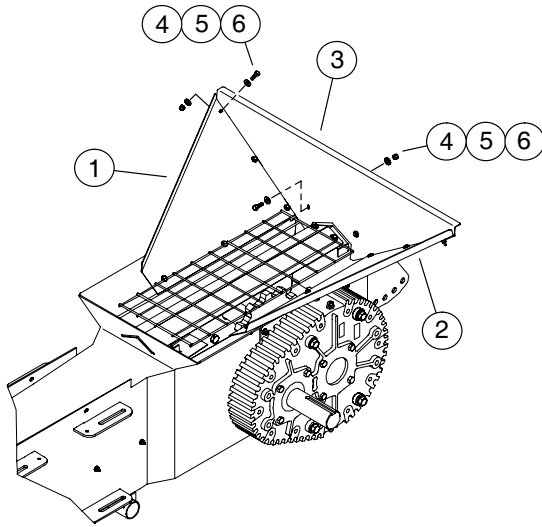

Ref. No.	Part No.	Description
1	1028749	Hopper Plate, Right
2	1028748	Hopper Plate, Left
3	1028747	Hopper Plate, Front
4	4618-1	Bolt, 1/4-20 x 1" G5 PLT
5	33022	Washer, 1/4" Flat PLT
6	4003	Nut, 1/4-20 Nylon Lock PLT

TRUSS COMPONENTS

f/ 70' MODELS

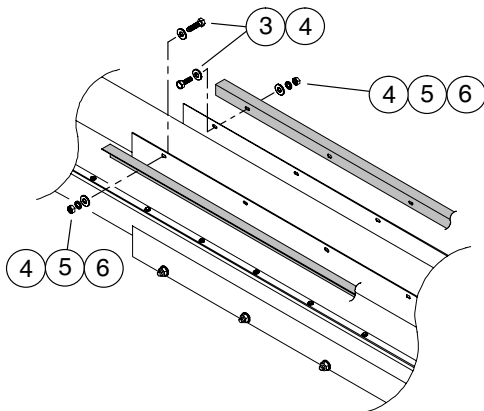
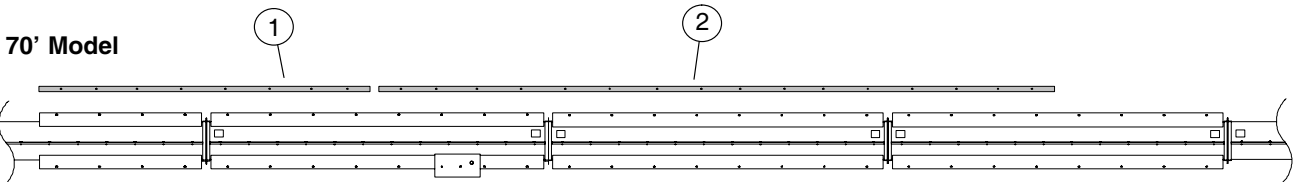

Ref. No.	Part No.	Description
1	552714	Truss Angle, Left 120" (3.05 m)
(1)	552714	Truss Angle, Right 120" (3.05 m)
2	552755	Truss Angle, Upper Left 240" (6.10 m)
(2)	552755	Truss Angle, Upper Right 240" (6.10 m)
3	33060	Bolt, 3/8-16 x 1" G5 PLT
4	33024	Washer, Flat 3/8" PLT
5	D1150	Washer, Lock 3/8" PLT
6	D1149	Nut, 3/8-16 Non-Lock PLT

PARTS LIST

TRUSS COMPONENTS

f/ 80' MODELS

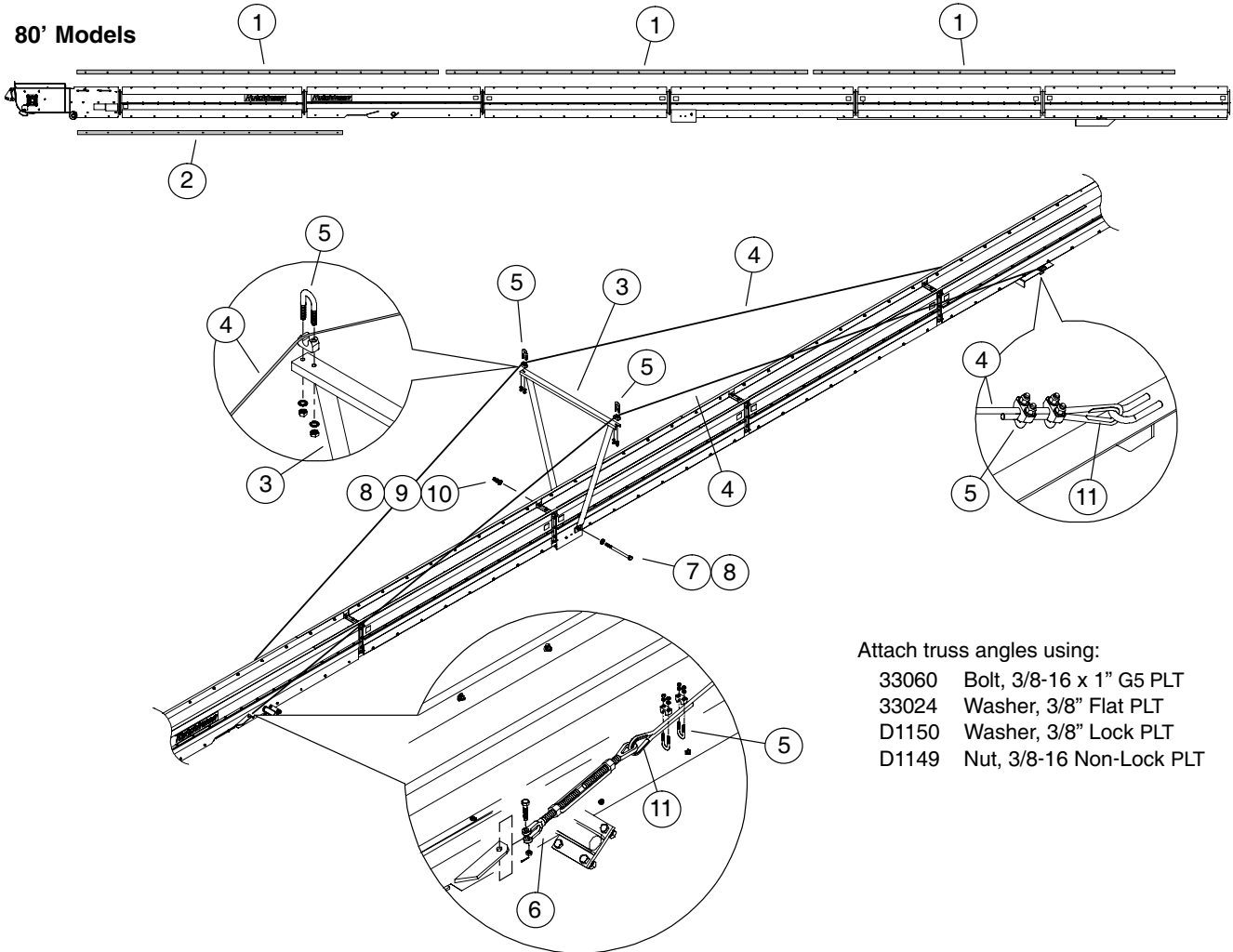

Attach truss angles using:

- 33060 Bolt, 3/8-16 x 1" G5 PLT
- 33024 Washer, 3/8" Flat PLT
- D1150 Washer, 3/8" Lock PLT
- D1149 Nut, 3/8-16 Non-Lock PLT

Ref. No.	Part No.	Description	Ref. No.	Part No.	Description
1	552715	Truss Angle, Left 240" (6.10 m)	5	3010L11	Clamp, Cable f/ 3/8" dia. cable
(1)	552715	Truss Angle, Right 240" (6.10 m)	6	3009L11	Turnbuckle, 5/8" x 12"
2	552755	Truss Angle, Bottom Left 180" (4.57 m)	7	631077	Bolt, 1/2-13 x 12 1/2"
(2)	552755	Truss Angle, Bottom Right 180" (4.57 m)	8	33025	Washer, 1/2" Flat PLT
3	130111	Support, Truss Center	9	D1143	Lock Washer, 1/2" PLT
4	552752	Cable, 3/8" dia. x 43' (13.11 m)	10	33138	Nut, 1/2-13 Nylon Lock PLT
			11	3005L1	Thimble f/ 3/8" cable

TRUSS COMPONENTS

f/ 90' MODELS

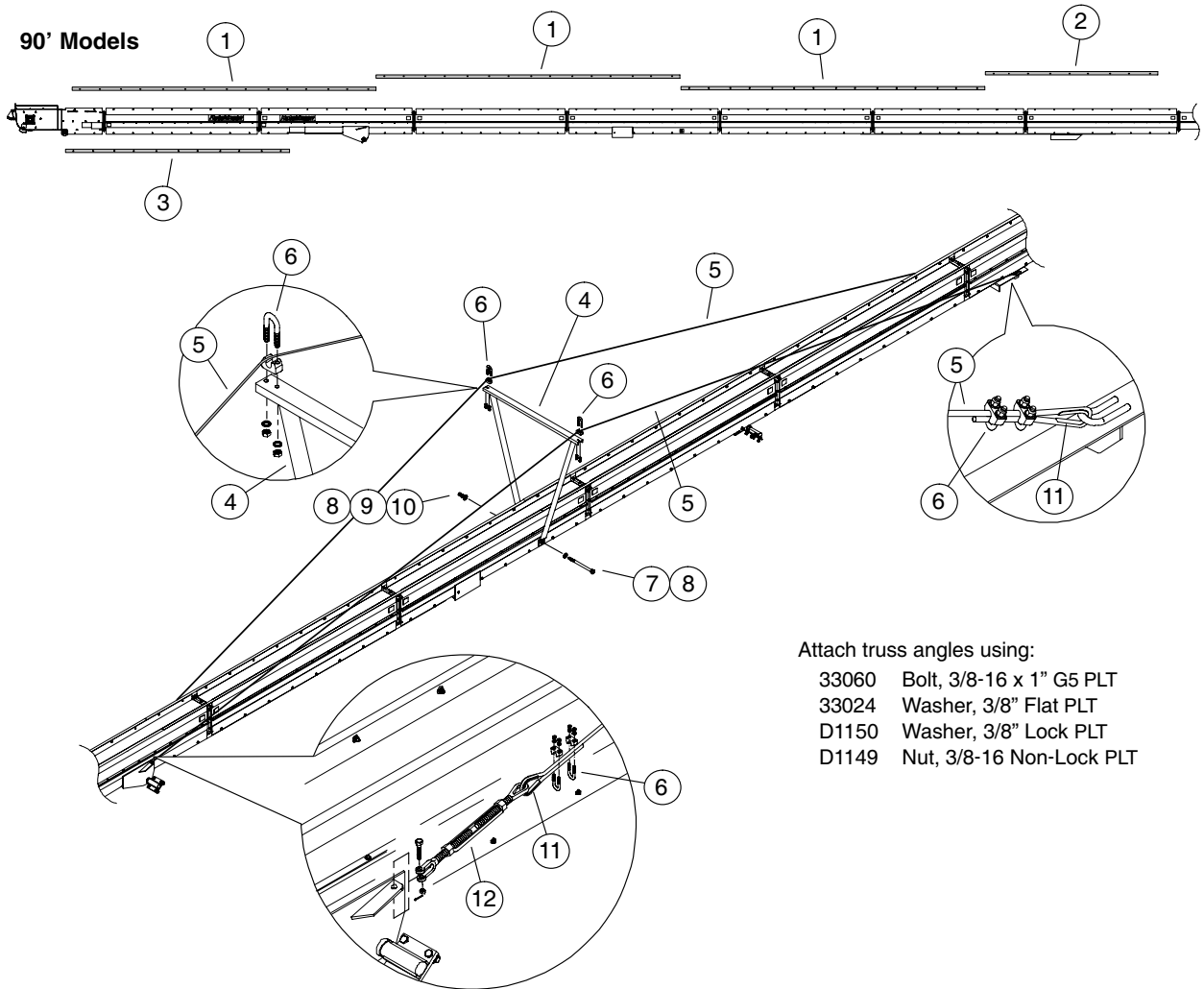

Attach truss angles using:

- 33060 Bolt, 3/8-16 x 1" G5 PLT
- 33024 Washer, 3/8" Flat PLT
- D1150 Washer, 3/8" Lock PLT
- D1149 Nut, 3/8-16 Non-Lock PLT

Ref. No.	Part No.	Description	Ref. No.	Part No.	Description
1	552715	Truss Angle, Left 240" (6.10 m)	4	130111	Support, Truss Center
(1)	552715	Truss Angle, Right 240" (6.10 m)	5	552746	Cable, 3/8" dia. x 47' (14.33 m)
2	552714	Truss Angle, Upper Left 120" (3.05 m)	6	3010L11	Clamp, Cable f/ 3/8" dia. cable
(2)	552714	Truss Angle, Upper Right 120" (3.05 m)	7	631077	Bolt, 1/2-13 x 12 1/2"
3	552709	Truss Angle, Bottom Right 173 1/4" (4.27 m)	8	33025	Washer, 1/2" Flat PLT
(3)	552710	Truss Angle, Bottom Left 173 1/4" (4.27 m)	9	D1143	Lock Washer, 1/2" PLT
			10	33138	Nut, 1/2-13 Nylon Lock PLT
			11	3005L1	Thimble f/ 3/8" cable
			12	3009L11	Turnbuckle, 5/8" x 12"

PARTS LIST

TRUSS COMPONENTS

f/ 100' MODELS

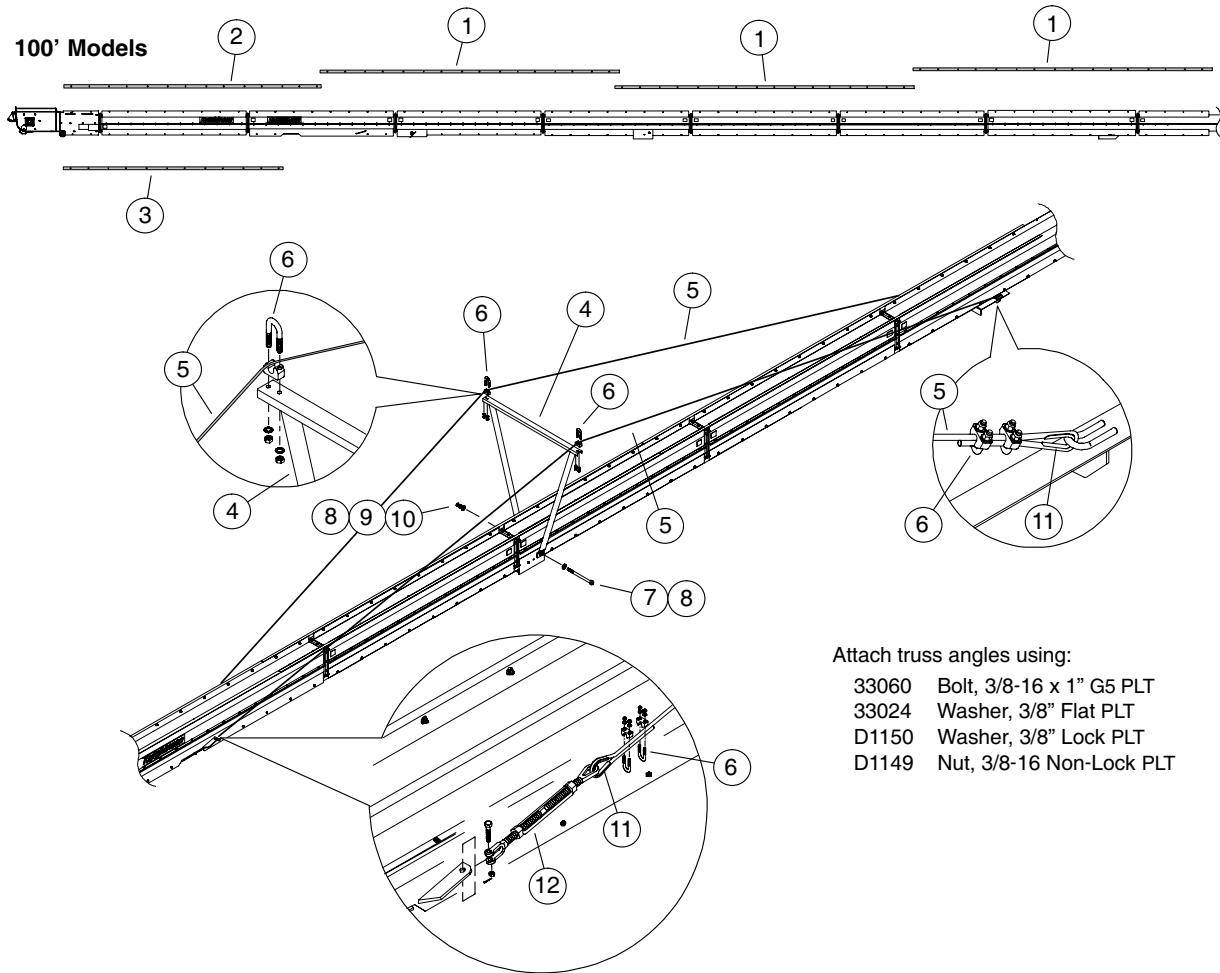

Attach truss angles using:

- 33060 Bolt, 3/8-16 x 1" G5 PLT
- 33024 Washer, 3/8" Flat PLT
- D1150 Washer, 3/8" Lock PLT
- D1149 Nut, 3/8-16 Non-Lock PLT

Ref. No.	Part No.	Description	Ref. No.	Part No.	Description
1	552715	Truss Angle, Left 240" (6.10 m)	4	130111	Support, Truss Center
(1)	552715	Truss Angle, Right 240" (6.10 m)	5	552813	Cable, 3/8" dia. x 53' (16.15 m)
2	552819	Truss Angle, Lower Left 210" (5.33 m)	6	3010L11	Clamp, Cable f/ 3/8" dia. cable
(2)	552819	Truss Angle, Lower Right 210" (5.33 m)	7	631077	Bolt, 1/2-13 x 12 1/2"
3	552755	Truss Angle, Bottom Right 180" (4.57 m)	8	33025	Washer, 1/2" Flat PLT
(3)	552755	Truss Angle, Bottom Left 180" (4.57 m)	9	D1143	Lock Washer, 1/2" PLT
			10	33138	Nut, 1/2-13 Nylon Lock PLT
			11	3005L1	Thimble f/ 3/8" cable
			12	3009L11	Turnbuckle, 5/8" x 12"

PARTS LIST

HEAD COMPONENTS

f/ 40', 50' 60' 65', 70',

80', 90' & 100' MODELS

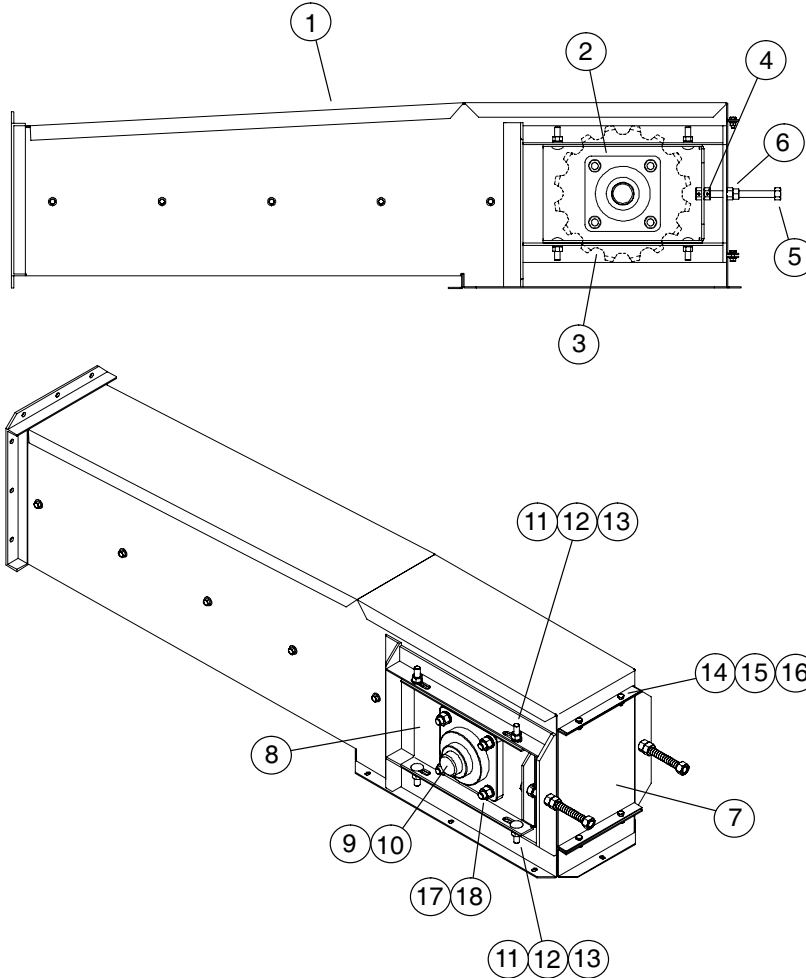

Ref. No.	Part No.	Description	Ref. No.	Part No.	Description
1	1002482	Head Weldment	10	4021L1	Key, 1/2" sq. x 2 3/4" long
2	2214C	Bearing, 4-Hole Flange 2" bore	11	1002243	Bolt, 1/2-13 x 1 1/2" Carriage
3	1005565	Sprocket, 12T 81C	12	D1169	Nut, 1/2-13 Non-Lock PLT
4	31121	Roll Pin, 3/16" x 1"	13	D1143	Washer, 1/2" Lock PLT
5	60951	Bolt, Take-Up Assembly	14	4701-1	Bolt, 5/16-18 x 3/4" G5 PLT
6	D1170	Nut, 5/8-11 Non-Lock PLT	15	33144	Washer, 5/16" Lock PLT
7	50647	Door, Head Assembly	16	33151	Nut, 5/16-18 Non-Lock PLT
8	61223	Slide, Take-Up Assembly	17	D1171	Washer, 5/8" PLT
9	552695	Shaft, 2" f/ Head Assembly	18	D1170	Nut, 5/8-11 Non-Lock PLT

PARTS LIST

PTO DRIVE COMPONENTS

f/ 40', 50', 60', 65'

70', 80', 90' & 100' MODELS

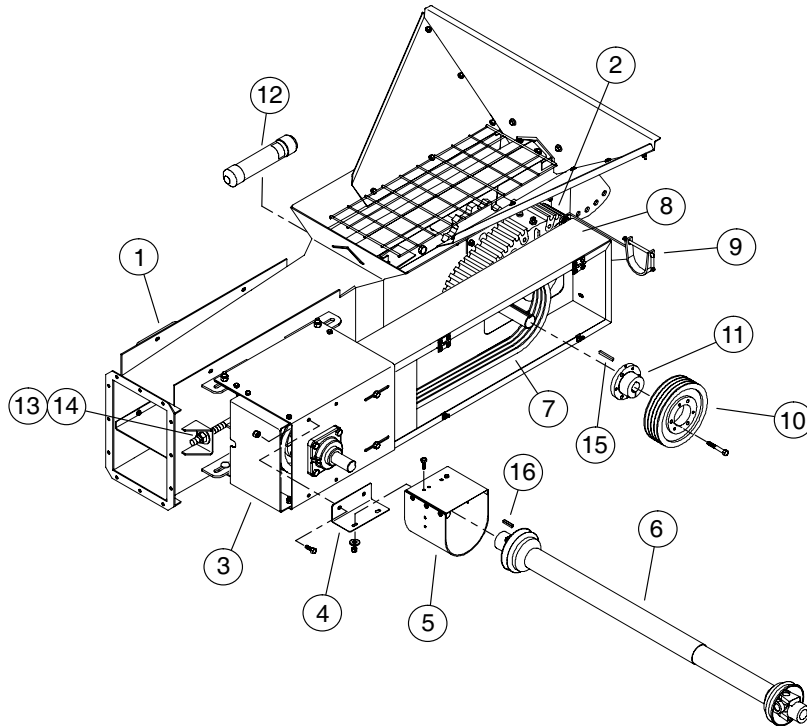

Ref. No.	Part No.	Description	Ref. No.	Part No.	Description
1	1028733	Boot Weldment (40', 50', 60' 65' & 70' Models)	7	40132	Belt, 97B
(1)	1033335	Boot Weldment (80', 90' & 100' Models)	8	1030708	Belt Guard, PTO Housing (40', 50, 60', 65' & 70')
2	1028204-1	Gearbox, Reduction 4:1 ratio (40', 50', 60', 65' & 70')	(8)	1033384	Belt Guard, PTO Housing (80', 90' & 100')
(2)	1031082	Gearbox, Reduction 8100 4:1 ratio (80', 90' & 100')	9	1030763	Support, PTO Driveline (40', 50', 60' 65' & 70' Models)
3	1030681	PTO Housing Assembly (40', 50', 60', 65' & 70')	(9)	1033073	Support, PTO Driveline (80', 90' & 100')
(3)	1033379	PTO Housing Assembly (80', 90' & 100')	10	3270A1	Sheave, QD 3B 8.6" P.D.
4	1033069	PTO Shield Hanger, (40', 50', 60', 65' & 70')	11	3295A1	Bushing, QD SK 1.50" bore (40', 50', 60' 65' & 70' Models)
(4)	1030699	PTO Shield Hanger (80', 90' & 100')	(11)	1032857	Bushing, QD SK 1.75" bore (80', 90' & 100')
5	1026217	U-Joint Shield (40', 50', 60' 65' & 70')	12	1004287	Container, Operator's Manual
(5)	862113	U-Joint Shield (80', 90' & 100')	13	D1152	Nut, 3/4-10 Non-Lock PLT
6	1027696	PTO Shaft, 60" 1.5 35R	14	33027	Washer, 3/4" Flat PLT
			15	4073A1	Key, 3/8" sq. x 3" long
			16	1038D	Key, 3/8" sq. x 2" long

PARTS LIST

PTO DRIVE HOUSING BREAKDOWN

f/ 40', 50', 60', 65' & 70' MODELS

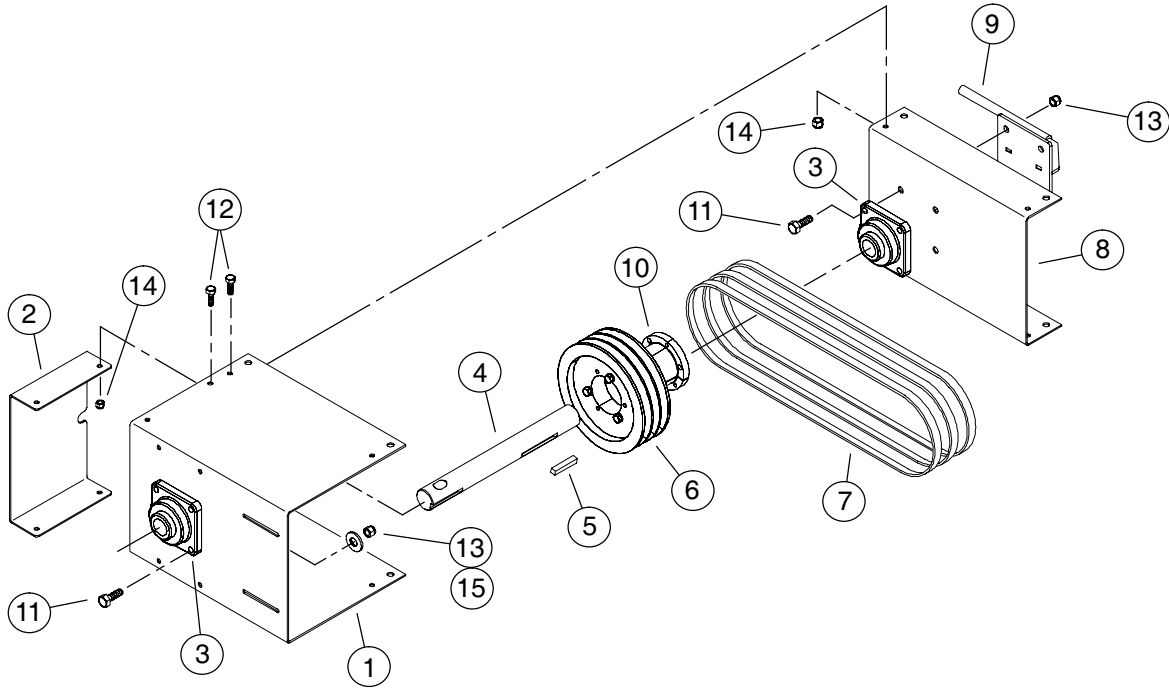

Ref. No.	Part No.	Description
1	1030685	Front PTO Bearing Support
2	1030687	PTO Pulley Shield
3	1010A	Bearing, 4-Hole Flange 1 1/2" bore
4	1030789	PTO Drive Sheave Shaft
5	1038D	Key, 3/8" sq. x 2" long
6	3244A1	Sheave, 7.4" P.D. 3B QD
7	40132	Belt, 97B
8	1030686	Rear PTO Bearing Support

Ref. No.	Part No.	Description
9	1030675	PTO Mount Tightener
10	3295A1	Bushing, QD SK, 1 1/2" bore
11	1002228	Bolt, 1/2-13 x 2" G5 PLT
12	33060	Bolt, 3/8-16 x 1" G5 PLT
13	33138	Nut, 1/2-13 Nylon Lock
14	33136	Nut, 3/8-16 Nylon Lock
15	33025	Washer, 1/2" Flat

PARTS LIST

Page P-16

PTO DRIVE HOUSING BREAKDOWN f/ 80', 90' & 100' MODELS

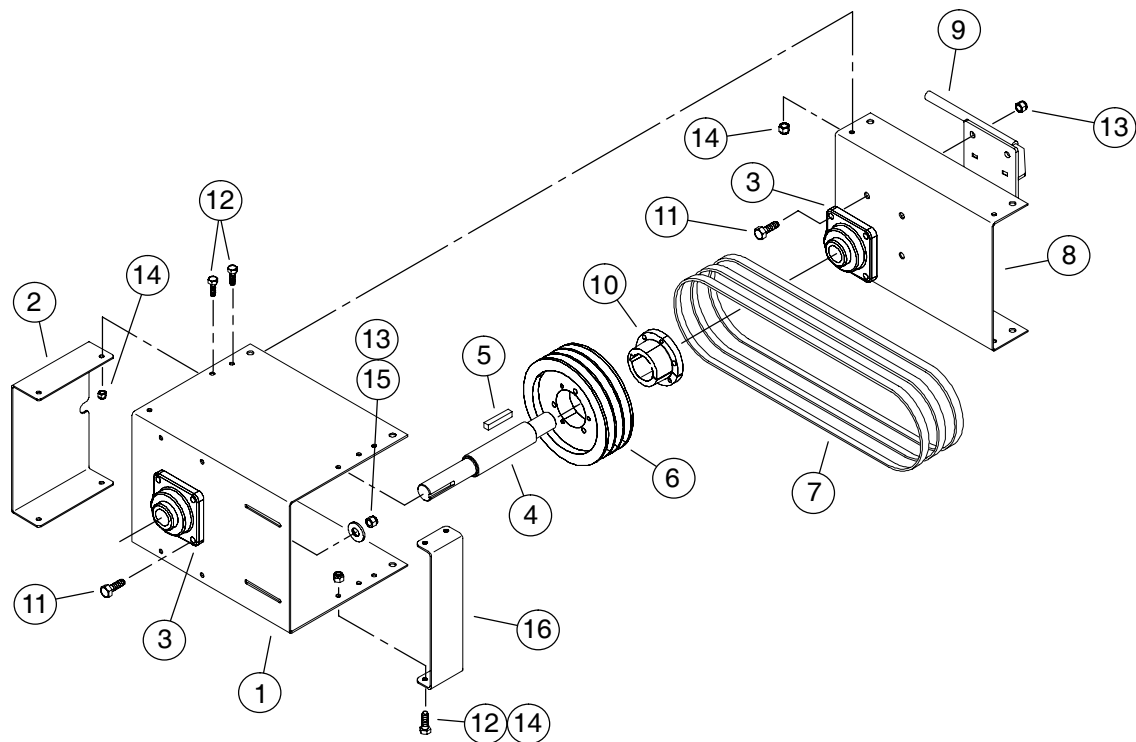

Ref. No.	Part No.	Description
1	1033380	Front PTO Bearing Support
2	1033382	PTO Pulley Shield
3	1010A	Bearing, 4-Hole Flange 1 1/2" bore
4	1033383	PTO Drive Sheave Shaft
5	4050A1	Key, 1/2" sq. x 2" long
6	3244A1	Sheave, 7.4" P.D. 3B QD
7	40132	Belt, 97B
8	1030686	Rear PTO Bearing Support

Ref. No.	Part No.	Description
9	1030675	PTO Mount Tightener
10	3194A1	Bushing, SK, 1 15/16" bore
11	1002228	Bolt, 1/2-13 x 2" G5 PLT
12	33060	Bolt, 3/8-16 x 1" G5 PLT
13	33138	Nut, 1/2-13 Nylon Lock
14	33136	Nut, 3/8-16 Nylon Lock
15	33025	Washer, 1/2" Flat
16	1033381	Short PTO Pulley Shield

DROP LEG JACK COMPONENTS

f/ 40', 50', 60', 65', 70', 80'

90' & 100' MODELS

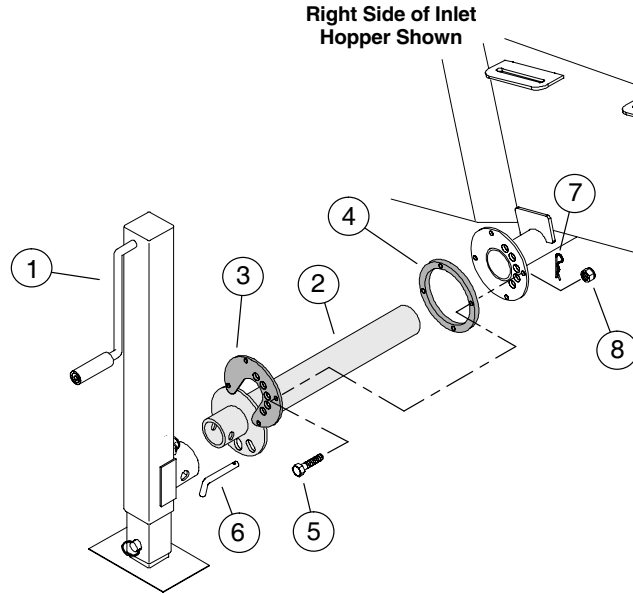

Ref. No.	Part No.	Description	Ref. No.	Part No.	Description
1	1042410	Jack, Drop Leg	5	33064	Bolt, 3/8" -16 x 1 3/4"
2	1042353	Jack Mount Weldment	6	1034329	Bent Pin, 5/8" dia. x 5" long
3	1033167	Outer Angle Plate	7	635164	Hair Pin, .094" dia. x 2" long
4	1033161	Spacer Plate	8	33136	Nut, 3/8"-16 Nylon Lock

DISCHARGE SPOUTS

f/ 40', 50', 60', 65', 70',

80', 90' & 100' MODELS

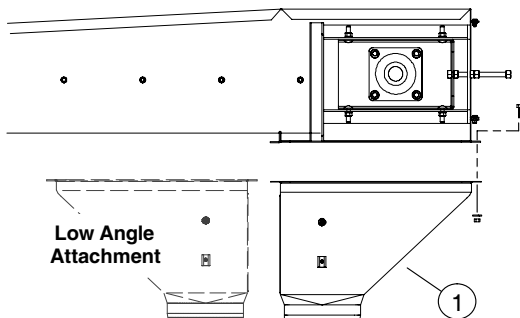

For low angle operation, the Discharge Spout can be attached reversed as shown

Ref. No.	Part No.	Description
1	10943	Spout, Discharge w/ 10" opening
(1)	1027466	Spout, Discharge w/ 12" opening

PARTS LIST

ELECTRIC DRIVE COMPONENTS

f/ 40', 50', 60', 65', 70'

80', 90' & 100' MODELS

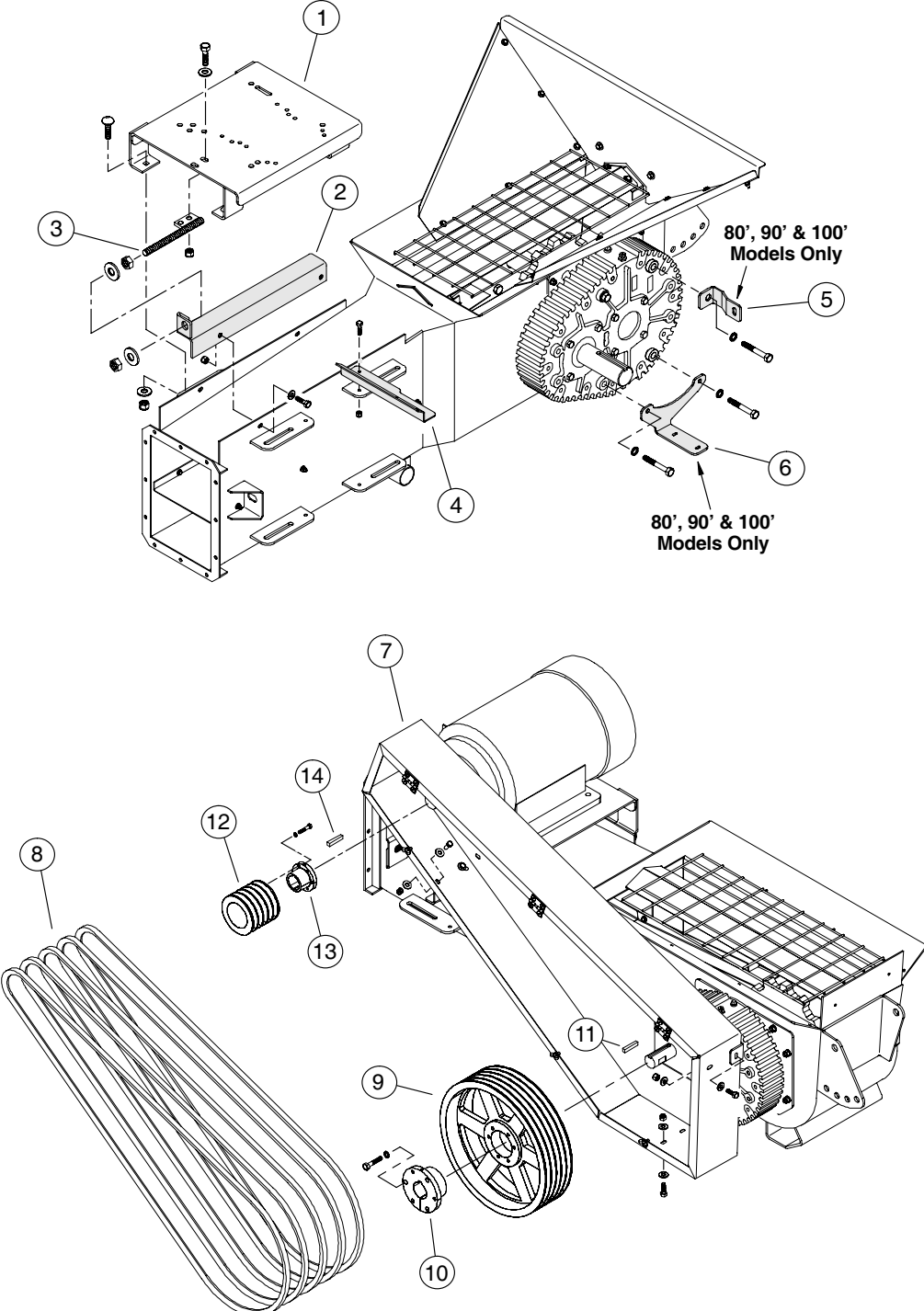

PARTS LIST

ELECTRIC DRIVE COMPONENTS

f/ 40', 50', 60', 65', 70',

80', 90' & 100' MODELS (con't.)

All parts listed are used on all models
unless otherwise noted.

Ref. No.	Part No.	Description
1	1030641	Plate, Motor Mount (40', 50', 60', 65' & 70' Models)
(1)	1033359	Plate, Motor Mount (80', 90' & 100' Models)
2	1030657	Bracket, Motor Mount Tightener
3	1029147	Adjustment Rod Weldment f/ Motor Mount
4	1030656	Bracket, Belt Guard (40', 50', 60', 65' & 70')
(4)	1033376	Bracket, Belt Guard, Upper (80', 90' & 100')
5	1033378	Bracket, Belt Guard, Top (80', 90' & 100')
6	1033375	Bracket, Belt Guard, Lower (80', 90' & 100')
7	1028326	Belt Guard (40', 50', 60', 65' & 70')
(7)	1033371	Belt Guard (80', 90' & 100')
8	40134	Belt, B105 (40', 50', 60', 65' & 70')
(8)	40133	Belt, B100 (80', 90' & 100')
9	3254A1	Sheave, QD 5B 15.4" P.D.
10	3073A1	Bushing, QD SF 1 1/2" (40', 50', 60', 65' & 70')
(10)	1030416	Bushing, QD SF 1 3/7" (80', 90' & 100')
11	1038D	Key, 3/8" sq. x 2" (40', 50', 60', 65' & 70')
(11)	4073A1	Key, 3/8" sq. x 3" (80', 90' & 100')
12	1030755	Sheave, QD 5B 4.2" P.D.
13	3089A1	Bushing, QD SD 1 5/8" (40', 50', 60', 65' & 70')
(13)	3280A1	Bushing, QD SD 1 7/8" (80', 90' & 100')
14	1038D	Key, 3/8" sq. x 2"

PARTS LIST

PTO DRIVELINE COMPONENTS

f/ 40', 50', 60', 65', 70'

80', 90' & 100' MODELS

Specifications:

U-Joint Type – 35R

Conveyor End – 1 1/2" Bore with 3/8" Key Seat

Tractor End – 1 3/8" – 6B Spline with Shear Bolt

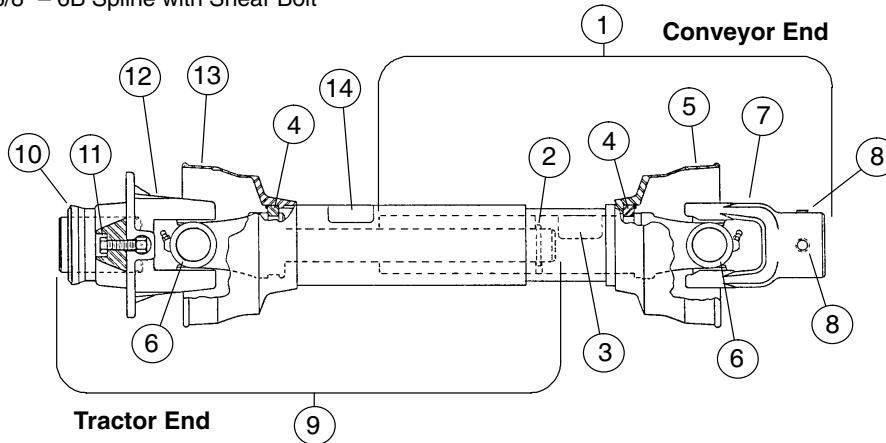

Replacement Parts are Not Lubricated.

Replacement parts must be lubricated at the time of assembly. Refer to the "Lubrication" Section in this manual for proper procedures.

NOTE: Repair parts for PTO drivelines can also be purchased directly from:

Weasler Engineering Inc.
West Bend, WI 53095
Ph: 414-338-2161

REF. NO.	PART NO.	DESCRIPTION	WEASLER PART NO.
--	1027696	PTO Driveline, Complete	242-22829
1	1028781	Joint & Tube Half Assembly	92-22829
		w/Guard (Conveyor End)	
2	1003691	Roll Pin, 1/4" x 1" long	11-10454
3	13-10022	Safety Sign, Inner Guard	13-10022
4	1028784	Inner Shield Bearing Retainer Kit	19-15126
5	1028785	Inner Guard (includes Ref. No. 4)	96-22829
6	1028783	35R U-Joint Cross Repair Kit	03-10045
7	1028787	End Yoke	35041-1572
8	33170	Setscrew, 3/8-16 x 3/8"	11-10215
9	1028782	Joint & Tube Half Assembly	93-22829
		w/Guard (Tractor End)	
10	1028788	Spring Lock Flange Repair Kit	26-15120
11	1018892 *	Shear Bolt and Nut Kit	
12	1028789	Yoke & Ball Shear Assembly	40-30011
13	1028786	Outer Guard (includes Ref. No. 4)	97-22829
14	13-10021	Safety Sign, Outer Guard	13-10021

* Shear Bolt Kit includes: Six (6) 3/8-16 x 1" Grade 8 Bolts and Locknuts.

PARTS LIST

HUB ASSEMBLY

f/ 40', 50', 60', 65',

70', 80', 90' & 100' MODELS

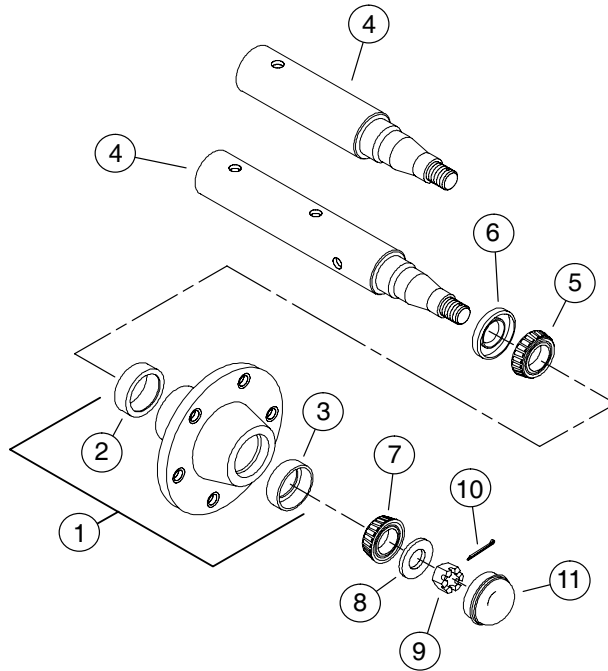

All items listed are used for all models unless otherwise noted.

Ref. No.	Part No.	Description	Ref. No.	Part No.	Description
1	90174	Hub, Wheel, 4-Bolt w/ Bearing Cups f/ 40' Models	6	106245	Grease Seal, HM18 (40' Models)
(1)	1025911	Hub, Wheel, 6-Bolt w/ Bearing Cups	(6)	1026088	Grease Seal, CR1 6289
2	---	•Inner Bearing Cup (40' Models) (Timken No. LM67010)	7	40551	Outer Cone Bearing (40' Models) (Timken No. LM11949)
(2)	1026090	•Inner Bearing Cup (Timken No. JLM506810)	(7)	3079R1	Outer Cone Bearing (Timken No. LM67048)
3	---	•Outer Bearing Cup (40' Models) (Timken No. LM11910)	8	106252	Washer (40' Models)
(3)	3148R1	•Outer Bearing Cup (Timken No. LM67010)	(8)	D1148	Washer
4	1001002	Spindle, f/ 4-Bolt Hub (40' Models)	9	106250	Slotted Nut (40' Models)
(4)	1033414	Spindle, f/ 6-Bolt Hub (50' Models)	(9)	D1147	Slotted Nut
(4)	1026682	Spindle, f/ 6 Bolt Hubs	10	D1146	Cotter Pin, 5/32" x 1 1/4" (40' Models)
5	1026089	Inner Cone Bearing (Timken JL69349)	(10)	107230	Cotter Pin, 5/32" x 1 3/4"
(5)	3079R1	Inner Cone Bearing (40' Models) (Timken No. LM67048)	11	106244	Dust Cap (40' Models)
			(11)	107234	Dust Cap

•Indented Parts Names Indicate these Parts are Included in the Previous Assembly.

PARTS LIST

Page P-22

UNDERCARRIAGE, WINCH, LIFT CABLE,
UPPER STOP, SLIDE & PULLEY ASSEMBLY
f/ 40', 50', 60' & 65' MODELS

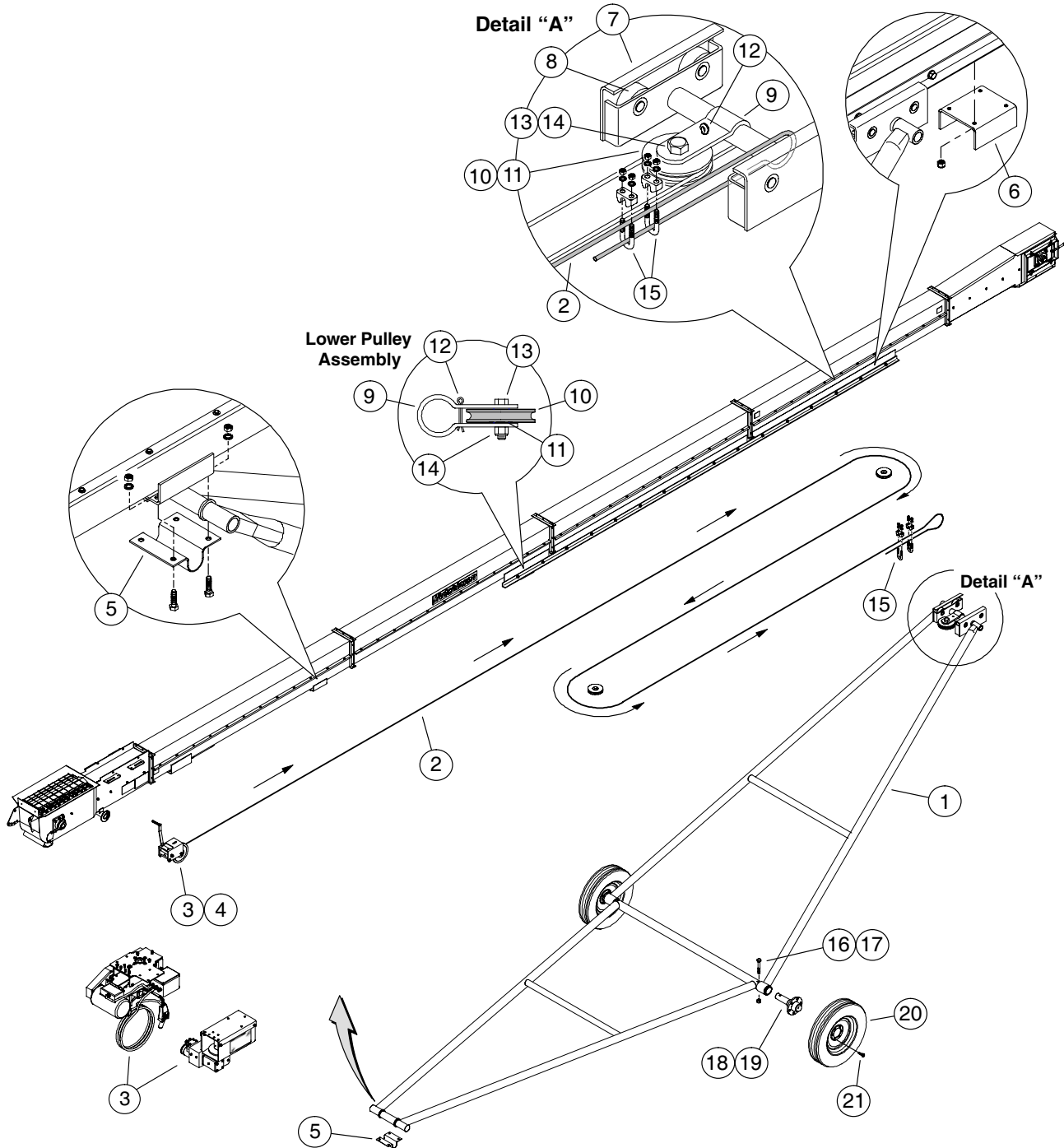

PARTS LIST

**UNDERCARRIAGE, WINCH, LIFT CABLE,
UPPER STOP, SLIDE & PULLEY ASSEMBLY
f/ 40', 50', 60' & 65' MODELS**

All items listed are used for all models unless otherwise noted.

Ref. No.	Part No.	Description	Ref. No.	Part No.	Description
1	1004805	Undercarriage (40' Models)	11	50079A1	Bushing f/ Cable Pulley
(1)	1002185	Undercarriage (50' Models)	12	D1263	Cotter Pin, 1/4" x 2" long
(1)	12668	Undercarriage (60' Models)	13	1002228	Bolt, 1/2-13 x 2" G5 PLT
(1)	6405A1	Undercarriage (65' Models)	14	33138	Nut, 1/2-13 Nylon Lock PLT
2	8381C	Cable, Lift (40' Models) 1/4" dia. x 51' long (6.5 mm x 15.54 m)	15	6369C	Clamp Cable, f/ 1/4" dia. Cable
(2)	551349	Cable, Lift (50' Models) 1/4" dia. x 70' long (6.5 mm x 21.34 m)	16	4911	Bolt, 1/2-13 x 3 1/2" G5 PLT (f/ 40' Models)
(2)	8396C	Cable, Lift (60' Models) 1/4" dia. x 82' long (6.5 mm x 24.99 m)	(16)	1002230	Bolt, 1/2-13 x 4" G5 PLT
(2)	8396C	Cable, Lift (65' Models) 1/4" dia. x 93' long (6.5 mm x 28.35 m)	17	33138	Nut, 1/2-13 Nylon Lock PLT
3	40302	Winch, K2550 Manual	18	1001002	Spindle, f/ 4-Bolt Hub (40' Models)
(3)	1006525	Winch, Hydraulic (6" drum)	(18)	1033414	Spindle, f/ 6-Bolt Hub (50' Models)
(3)	1006526	Winch, Electric (2 HP)	(18)	1026682	Spindle, f/ 6-Bolt Hub (60' & 65' Models)
4	41595	Handle, Winch (f/ K2550)	19	90174	Hub, 4-Bolt, w/ Bearing Cups (40' Models)
5	8387D	Clamp, Undercarriage Mount	(19)	1025911	Hub, 6-Bolt w/ Bearing Cups
6	5373A1P	Upper Stop	20	6393D	Wheel Rim, 15 x 4.5, f/ 4-Bolt
7	630081	Slide Assembly, Undercarriage	(20)	1025912	Wheel Rim, 16" x 6, f/ 6-Bolt
8	54395	Roller, f/ Slide Assembly	(20)	420156	Tire, 15" 205/7515 (40' Models)
9	5120A1	Clevis, Pulley (f/ Undercarriage)	(20)	1025913	Tire, 16" 235/85R16
10	3223A1	Pulley, f/ 1/4" Cable	21	106241	Lug Bolt

PARTS LIST

Page P-24

WINCH, LIFT CABLE,
SLIDE & PULLEY ASSEMBLY
f/ 70', 80', 90' & 100' MODELS

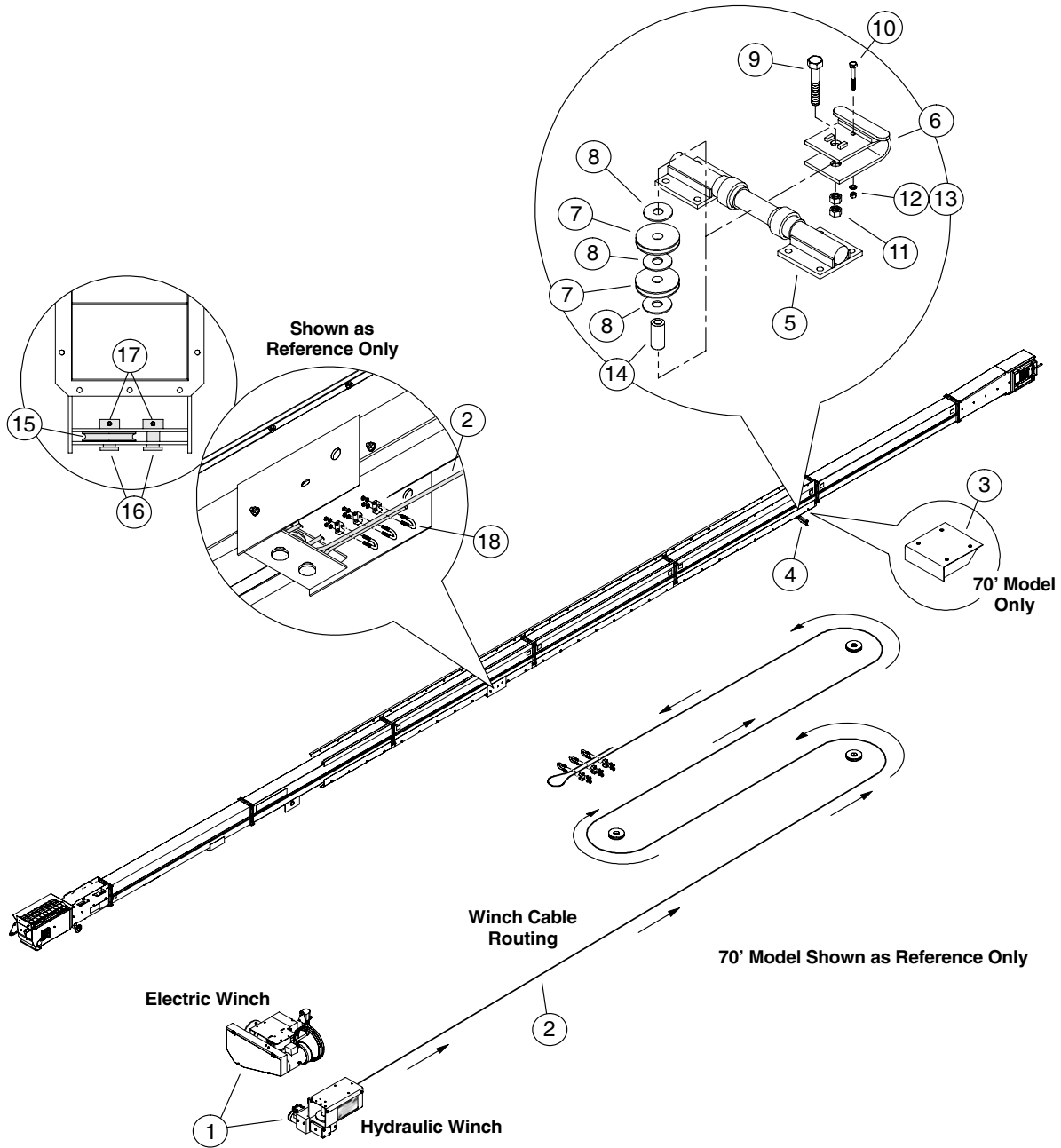

Refer to Page P-28 for Hydraulic Winch Parts Breakdown
 Refer to Page P-29 for Electric Winch Parts Breakdown

PARTS LIST

WINCH, LIFT CABLE,
SLIDE & PULLEY ASSEMBLY
f/ 70', 80', 90' & 100' MODELS

All items listed are used with all models unless otherwise noted.

Ref. No.	Part No.	Description
1	1006525	Winch, Hydraulic
(1)	1032553	Winch, Electric
2	52720	Cable, Lift, f/ 70' Models, 3/8" dia. x 110' long (33.53 m)
(2)	552753	Cable, Lift, f/ 80' Models, 3/8" dia. x 122' long (37.19 m)
(2)	552747	Cable, Lift, f/ 90' Models, 3/8" dia. x 143' long (43.59 m)
(2)	552814	Cable, Lift, f/ 100' Models, 3/8" dia. x 160' long (48.77 m)
3	631130	Upper Stop f/ 70' Models Only
4	631078	Slide and Pulley Assembly
5	631082	•Mounting Shaft f/ Undercarriage Arms
6	631081	•Clevis Weldment w/ Slide
7	1045050	•Pulley f/ 3/8" Cable
8	1028506	•Washer, 1" Flat
9	33377	•Bolt, 1-8 x 4 1/2" G5 PLT
10	4827	•Bolt, 3/8-16 x 3 1/2" G5 PLT
11	D1158	•Nut, 1-8 Non-Lock PLT
12	D1150	•Washer, 3/8" Lock PLT
13	D1149	•Nut, 3/8-16 Non-Lock PLT
14	5056R1	•Bushing, Cable Anchor
15	40305	Pulley f/ 3/8" Cable
16	4127A1	Pin, Pulley Clevis
17	33243	Roll Pin, 5/16" x 1 3/4" long
18	3010L11	Cable Clamp f/ 3/8" Cable

•Indented Parts Names Indicate these Parts are Included in the Previous Assembly.

PARTS LIST

UNDERCARRIAGE COMPONENTS f/ 70' MODELS

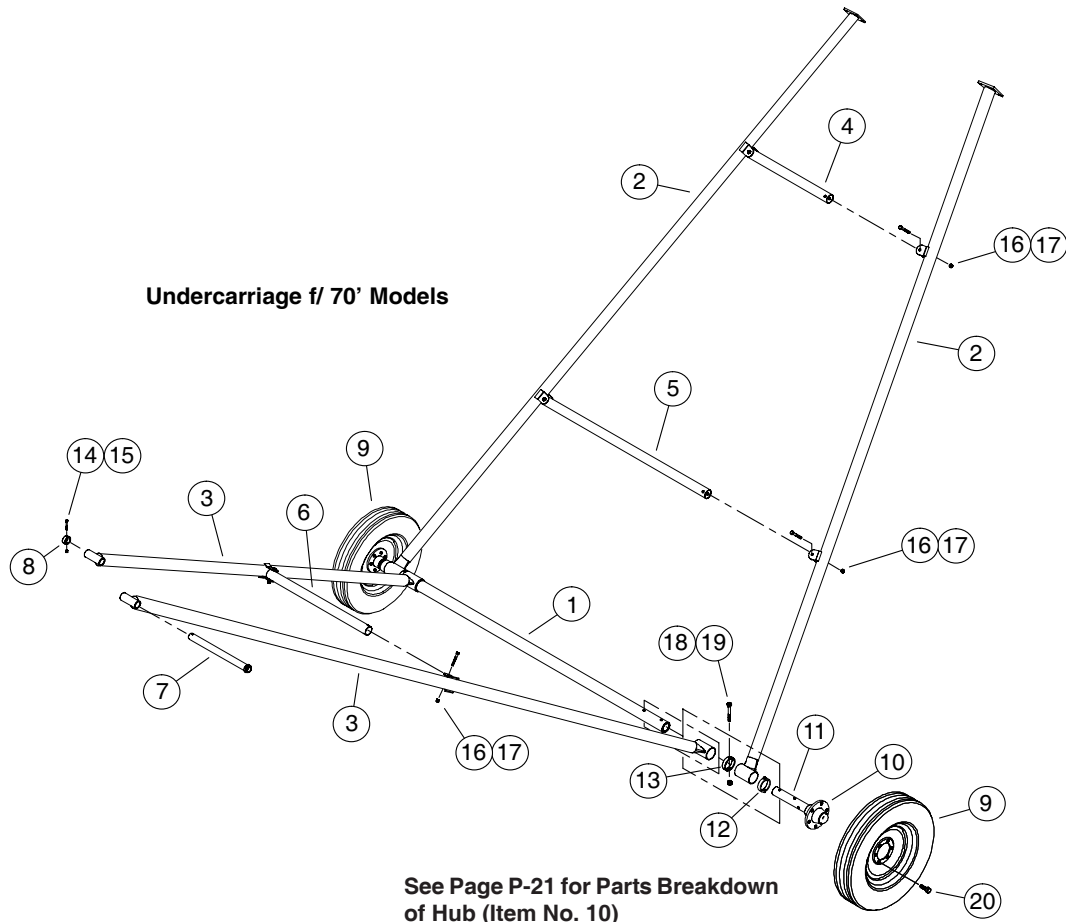

Ref. No.	Part No.	Description	Ref. No.	Part No.	Description
1	631128	Axle, Undercarriage f/ 70' Models	10	1025911	Hub, w/ Bearing cups
2	631129	Arm, Upper f/ 70' Models	11	1026682	Spindle, f/ 16" Wheels & Hubs
3	631127	Arm, Lower f/ 70' Models	12	62892	Collar, w/ Setscrews
4	51148A1	Crossbrace, Upper, 42 1/4" (1.07 m)	13	54732	Collar, f/ axle to spindle
5	552912	Crossbrace, Upper, 76" (1.93 m)	14	33068	Bolt, 3/8-16 x 3" G5 PLT
6	552911	Crossbrace, Lower, 52" (1.32 m)	15	33136	Nut, 3/8-16 Nylon Lock PLT
7	631041	Pin, Undercarriage Mount	16	1002236	Bolt, 5/8-11 x 4 1/2" G5 PLT
8	50807A1	Collar, Undercarriage Mount Pin	17	33139	Nut, 5/8-11 Nylon Lock PLT
9	1026197	Wheel & Tire Assembly, 16"	18	1002230	Bolt, 1/2-13 x 4" G5 PLT
(9)	1025912	•Rim, 16"	19	33138	Nut, 1/2-13 Nylon Lock PLT
(9)	1025913	•Tire, 16" 235/85R16	20	106241	Lug Bolt, 1/2-20

•Indented Parts Names Indicate these Parts are Included in the Previous Assembly.

UNDERCARRIAGE COMPONENTS

f/ 80', 90' & 100' MODELS

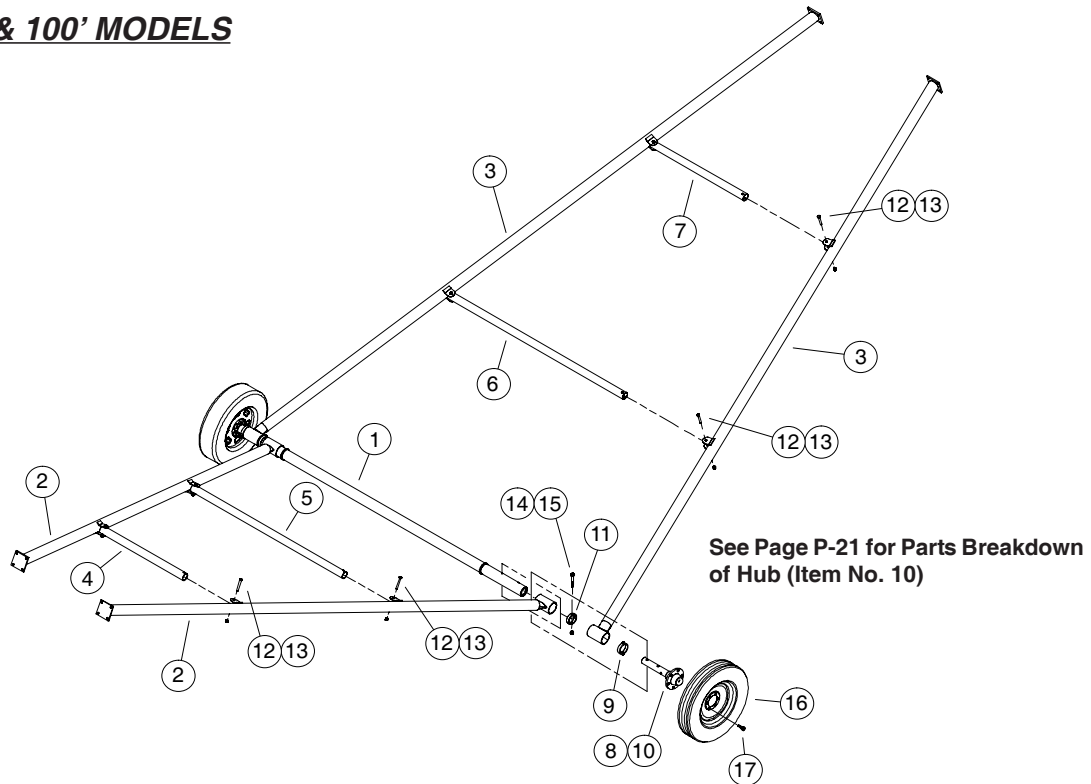

Ref. No.	Part No.	Description	Ref. No.	Part No.	Description
1	6958A1	Axle, Undercarriage f/ 80' Models	(6)	552818	Crossbrace, Long (upper arm) 99 5/16" (2.52 m), f/ 100' Models
(1)	6967A1	Axle, Undercarriage f/ 90' & 100' Models	7	552749	Crossbrace, Short (upper arm) 43 1/2" (1.10 m), f/ 80' Models
2	6973A1	Arm, Lower f/ 80' Models	(7)	51148A1	Crossbrace, Short (upper arm) 42 1/4" (1.07 m), f/ 90' Models
(2)	631079	Arm, Lower f/ 90' Models	(7)	552816	Crossbrace, Short (upper arm) 56 7/32" (1.43 m), f/ 100' Models
(2)	6971A1	Arm, Lower f/ 100' Models	8	1026682	Spindle, f/ 16" Wheels & Hubs
3	6971A1	Arm, Upper f/ 80' Models	9	62892	Collar, w/ Setscrews
(3)	631080	Arm, Upper f/ 90' Models	10	1025911	Hub, 6-Bolt w/ Bearing cups
(3)	6972A1	Arm, Upper f/ 100' Models	11	54732	Collar, f/ axle to spindle
4	552748	Crossbrace, Short (lower arm) 39 3/4" (1.01 m), f/ 80' Models	12	1002236	Bolt, 5/8-11 x 4 1/2" G5 PLT
(4)	51148A1	Crossbrace, Short (lower arm) 42 1/4" (1.07 m), f/ 90' Models	13	33139	Nut, 5/8-11 Nylon Lock PLT
(4)	552815	Crossbrace, Short (lower arm) 47 11/16" (1.21 m), f/ 100' Models	14	1002230	Bolt, 1/2-13 x 4" G5 PLT
5	552750	Crossbrace, Long (lower arm) 72" (1.83 m), f/ 80' Models	15	33138	Nut, 1/2-13 Nylon Lock PLT
(5)	51172A1	Crossbrace, Long (lower arm) 95 5/8" (2.43 m), f/ 90' Models	16	1026197	Wheel & Tire Assembly, 16"
(5)	552817	Crossbrace, Long (lower arm) 90 3/16" (2.29 m), f/ 100' Models	(16)	1025912	•Rim, 16" 6-Bolt
6	552751	Crossbrace, Long (upper arm) 81" (2.06 m), f/ 80' Models	(16)	1025913	•Tire, 16" 235/85R16
(6)	51172A1	Crossbrace, Long (upper arm) 95 5/8" (2.43 m), f/ 90' Models	17	106241	Lug Bolt, 1/2-20

•Indented Parts Names Indicate these Parts are Included in the Previous Assembly.

PARTS LIST

HYDRAULIC WINCH COMPONENTS

f/ 40', 50', 60', 65',

70', 80', 90' & 100' MODELS

Complete Winch Ay.

1006525: 40', 50', 60', 65',
70' & 80' Models

1028865: 90' & 100' Models

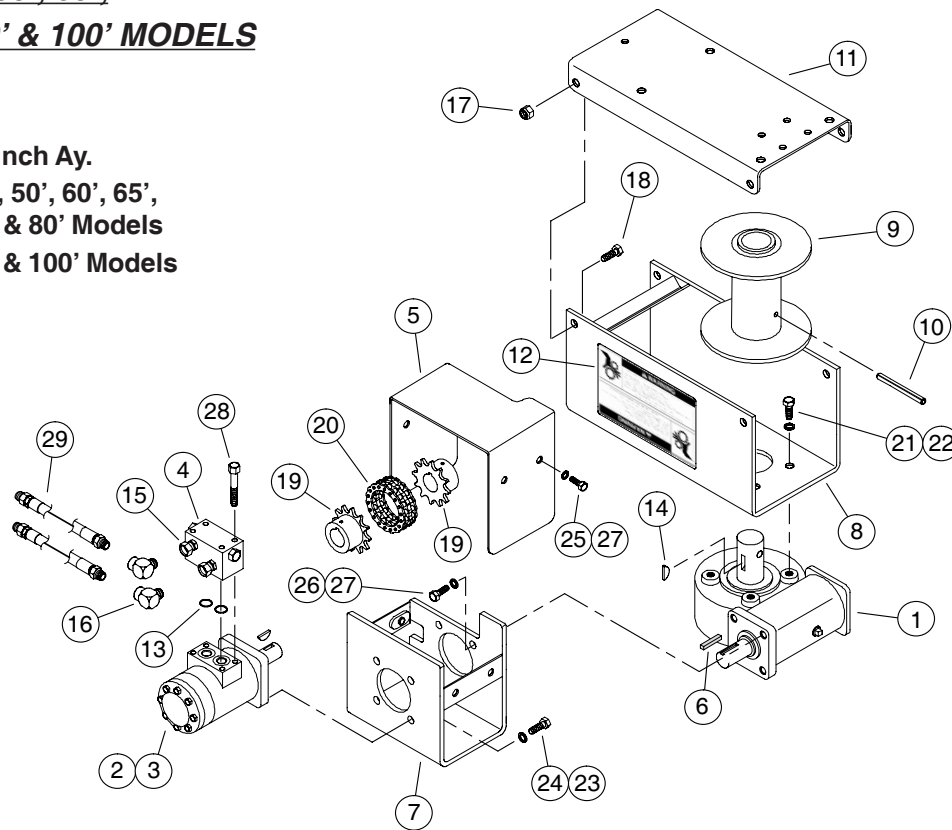

All items listed are used with all models unless otherwise noted.

Ref. No.	Part No.	Description	Ref. No.	Part No.	Description
1	1034615	Superior Gearbox, 20:1	15	1022123	Hydraulic Adapter w/ Restrictor
2	41133	Hydraulic Motor, "H" Series	16	106413	Elbow, 90° Hydraulic (1/2" male to 1/2" female NPT)
3	- - -	Woodruff Key included w/ hydr. motor	17	33138	Nut, 1/2-13 Nylon Lock PLT
4	1022004	Valve, Pressure Relief	18	33082	Bolt, 1/2-13 x 1 1/4" G5 PLT
5	1043177	Shield f/ Hydraulic Winch	19	3198A1	Flex Coupler, RC 1.000 Half
6	8371C	Key, 1/4" sq. x 1 1/2" long	20	3146A91	Chain, RC-60
7	1043180	Hydraulic Motor Mount	21	33294	Bolt, 1/2-13 x 1" G5 PLT
8	1007014	Frame w/ Decal, f/ 40' thru 80'	22	D1143	Lock Washer, 1/2" PLT
(8)	1028868*	Frame f/ 90' & 100' Models	23	33309	Bolt, 3/8-16 x 3/4" G5 PLT
9	1006520	Drum, f/ 40' thru 80' Models	24	D1150	Lock Washer, 3/8"
(9)	1028866	Drum, 8" f/ 90' & 100' Models	25	4701-1	Bolt, 5/16" 18 x 3/4" G5 PLT
10	33190	Roll Pin, 5/16" x 2 1/2" long	26	33046	Bolt, 5/16-18 x 1" G5 PLT
11	1006523	Plate, Frame Top f/ 40' thru 80'	27	33144	Lock Washer, 5/16" PLT
(11)	1028867	Plate, Frame Top f/ 90' & 100'	28	1002217	Bolt, 5/16-18 x 2 1/2" G5 PLT
12	1006559	Warning Decal	29	1032202	Hose, Hydraulic, 3/8" x 18' f/ 40' to 65' models
13	41129	O-Ring f/ Pressure Relief Valve	(29)	1041450	Hose, Hydraulic, 3/8" x 28' f/ 70' to 100' Models
14	1007288	Woodruff Key #1008			

*Order decal separately

ELECTRIC WINCH COMPONENTS f/ 40', 50', 60' & 65' MODELS

IMPORTANT! The 1006526 winch requires a dedicated 110V, 20 amp circuit. Also any power cord over 25' (7.62 m) must be a 10-3 wire. 12-3 is okay for cords less than 25' (7.62 m).

Complete Winch Ay.
1006526: 40', 50', 60', 65' Models

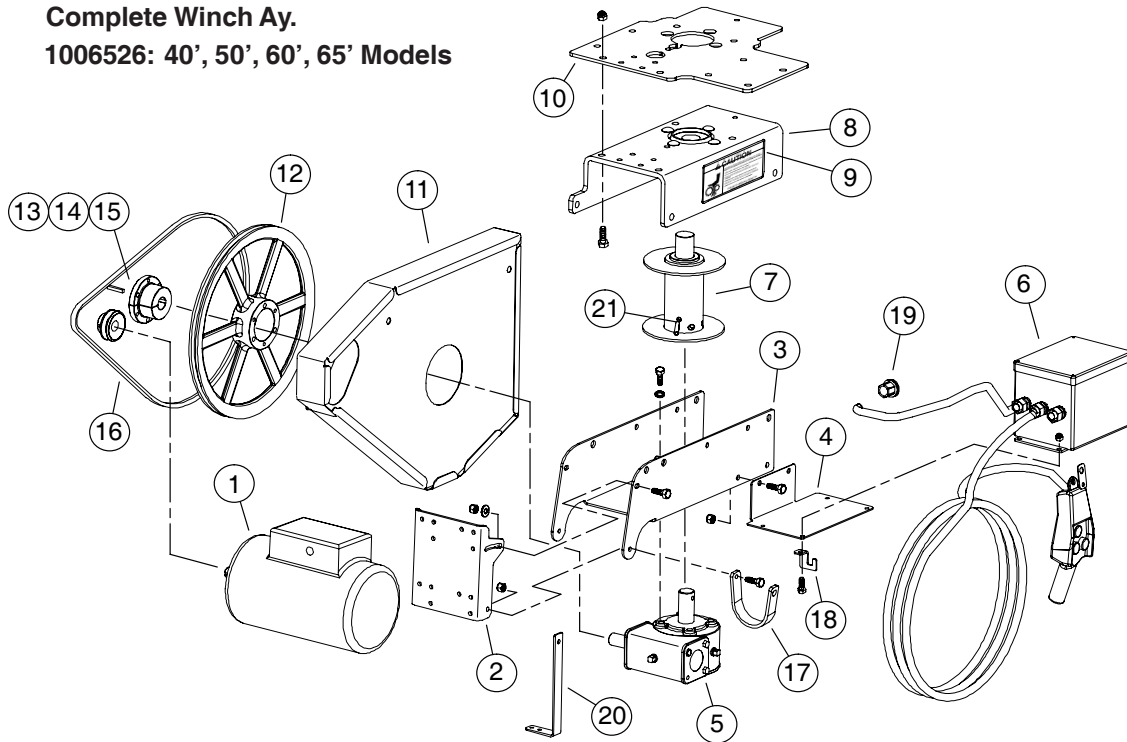

Ref. No.	Part No.	Description	Ref. No.	Part No.	Description
1	1011044	Motor, 2HP, 1PH 120V	12	40681	Sheave, 15.4", 1B
2	1044590	Motor Mount f/ Small Winch	13	3294A1	Bushing, QD SK 1.00"
3	1044644	Bottom Plate f/ Durst Winch	14	40165	Sheave, 2.5", 7/8" Bore
4	1044384	Control Box Mount Plate	15	8371C	Key, 1/4" sq. x 1 1/2" long
5	1034615	Gearbox, Superior 20:1	16	1023004	V-Belt, B-59
6	1042691	Control Box w/ Pendant	17	1035351	Cable Holder Strap
7	1044614	Drum f/ Small Elec. Winch	18	1044372	Hanger f/ Pendant
8	1044612	Top Frame f/ Small Winch	19	1038412	Adapter, 1/2" Conduit
9	1006554	•Decal, Caution	20	1044591	Bracket f/ Belt Guard
10	1038158	Adapter Plate f/ Winch	21	33190	Roll Pin, 5/16" x 2 1/2" long
11	1044627	Belt Guard f/ Small Elec. Winch			

•Indented Parts Names Indicate these Parts are Included in the Previous Assembly.

PARTS LIST

ELECTRIC WINCH COMPONENTS

f/ 70', 80', 90' & 100' MODELS

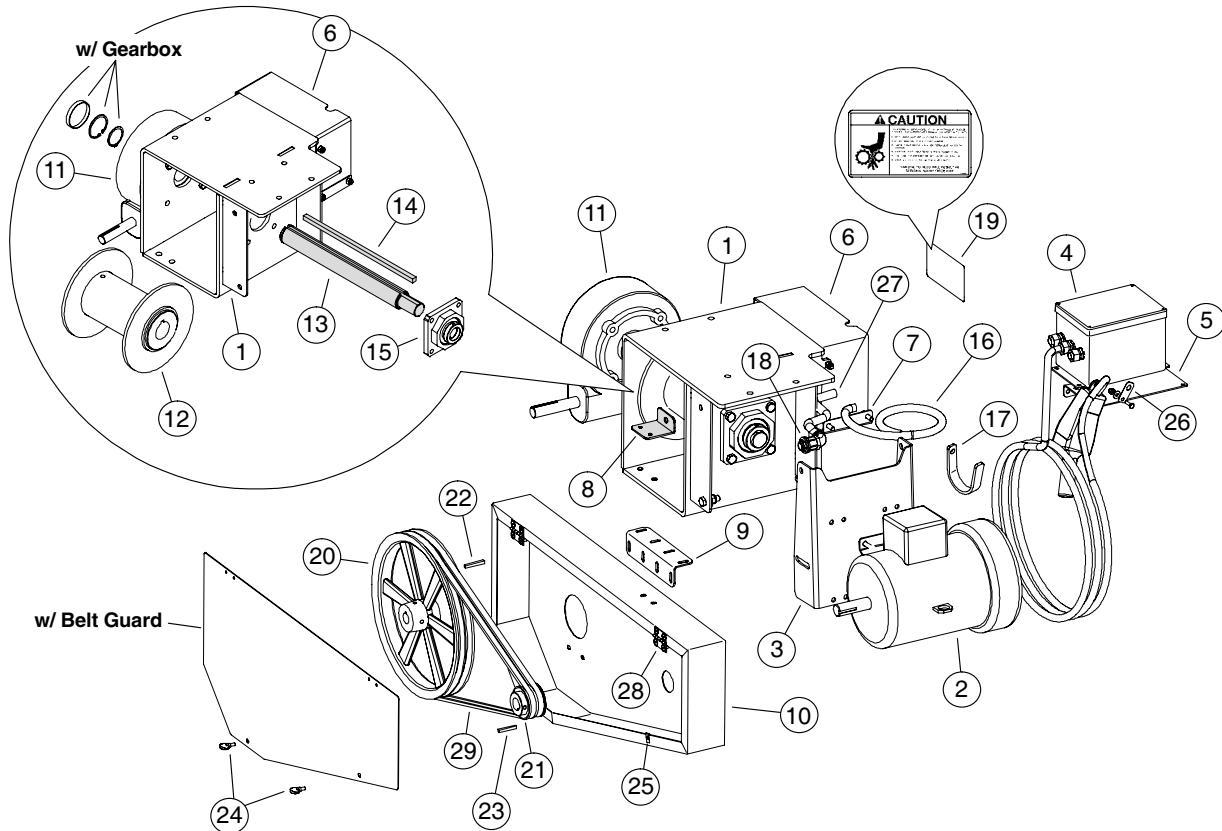

The complete winch assembly (Part No. 1032553) consists of all items listed below.

Ref. No.	Part No.	Description	Ref. No.	Part No.	Description
1	1032539NF	Frame, Winch Weldment	17	1035351	Strap, Pendant Cable Holder
2	1034250	Motor, 5 HP, 3PH (184T frame)	18	1038412	Adapter, Conduit
3	1032555	Plate, Motor Mount	19	1006554	Decal, Caution, f/ Electric Winch
4	1042690	Control Box w/ Pendant	20	40157	Sheave, 15" O.D. x 1" bore 2B
5	1043334	Plate, Control Box Mount	21	40191	Sheave, 3" O.D. x 1 1/8" bore 2B
6	1035366	Guard, Upper Half	22	4045A1	Key, 1/4" sq. x 2" long
7	1035367	Guard, Lower Half	23	8371C	Key, 1/4" sq. x 1 1/2" long
8	1032818	Bracket, Upper Belt Guard	24	1013131	Wing Bolt, 1/4" x 1/2"
9	1032817	Bracket, Bottom Belt Guard	25	1013133	Nut, 1/4" Tinnerman
10	1038341	Belt Guard	26	1043576	Hanger, f/ Pendant
11	1032536-1	Gearbox, 50:1 (LH assembly)	27	1043588	Cord, Electric Motor
12	1032551	Drum, Winch	28	1013215	Hinge, 2" x 1 3/4"
13	1032548	Shaft, f/ Winch	29	1009129	Belt, B-73
14	1032840	Key, 1/2" sq. x 16" long	--	1006763	Clamp, Electric Cord (Not Shown)
15	1029745	Bearing, 1 1/2" (4 hole flange)			
16	1035342	Cable, Power Supply, 12/4-600V 20 amps, .650" x 5' long			

PARTS LIST

MANUAL WINCH COMPONENTS f/ 40', 50', 60' & 65' MODELS

Complete Winch - Part No. 40302 (w/o Handle)
Fulton Model K-2550

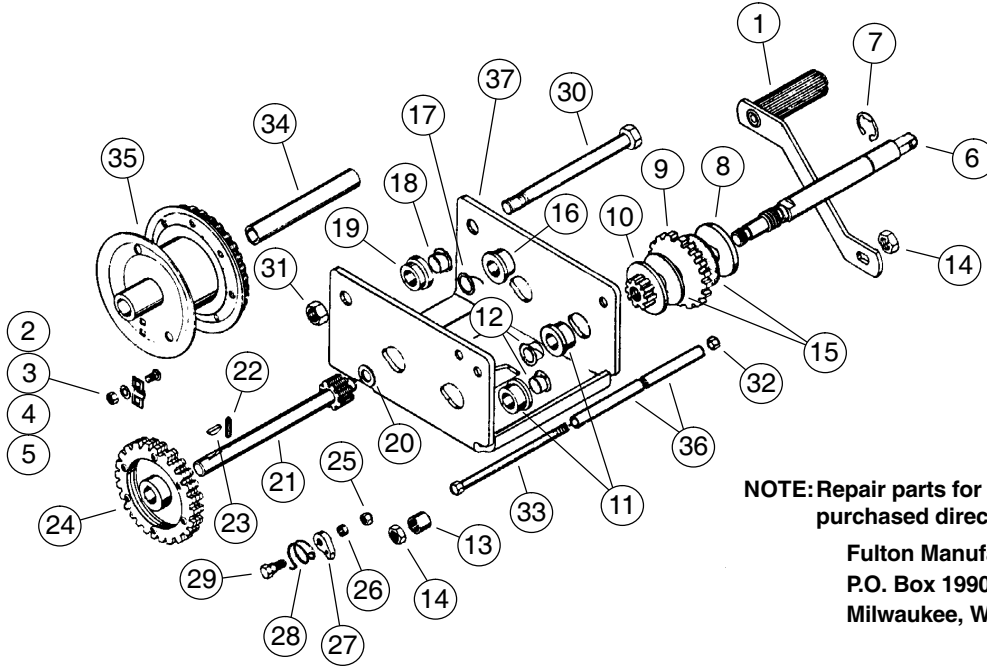

NOTE: Repair parts for winch can also be purchased directly from:

Fulton Manufacturing Co.
P.O. Box 19903
Milwaukee, WI 53219

Items 30 thru 33 are standard hardware items that can be purchased locally.
Items 34 thru 37 are not available as separate parts because of the precision assembly required.
If these parts require replacement, a new winch unit is recommended.
Refer to the materials supplied by the winch manufacturer for more information.

Ref. No.	Description	Hutchinson/Mayrath Part No.	Fulton Part No.
1	Winch Handle	41595	2461S01
2-5	Cable Keeper Kit	41600	5621S01
6-14	Input Shaft Kit	41598	1565S01
15	Friction Disc	41601	1565S01
16-24	Intermediate Shaft Kit	41599	1569S01
25-29	Ratchet Kit	40836	6730S00

PARTS LIST

CHAIN & PADDLE ASSEMBLY

81XHH CHAIN, 48 PITCH

f/ 40', 50', 60', 65', 70',

80', 90' & 100' MODELS

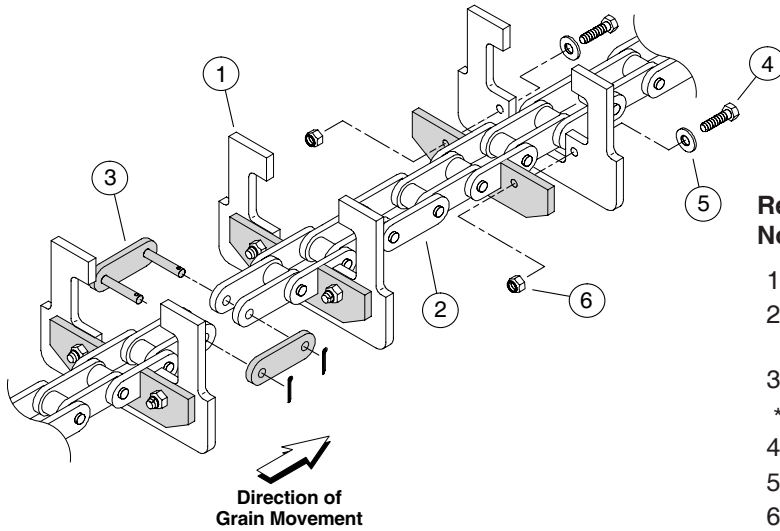

Ref. No.	Part No.	Description
1	1005441	Paddle, 3/8" thick UHMW plastic
2	1038007	Chain w/ Brackets 81XHH, 125 7/32" long (3.18 m) 48 Pitch
3	1017077	Connecting Link f/ 81XHH Chain
*	1034495	Offset Connecting Link
4	4736	Bolt, 5/16-18 x 1 1/2" G5 PLT
5	33023	Washer, 5/16" Flat PLT
6	33135	Nut, 5/16-18 Nylon Lock PLT
* Not Shown		

4:1 REDUCER GEARBOX

f/ 40', 50', 60', 65' & 70' MODELS

Reducer Part No. 1028204-1

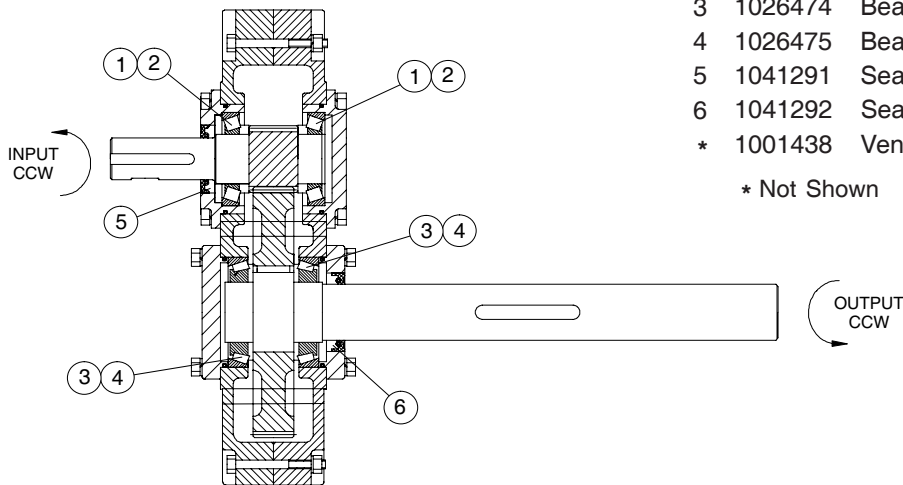

Ref. No.	Part No.	Description
1	1026473	Bearing Cone, 25590
2	1021344	Bearing Cup, 25520
3	1026474	Bearing Cone, 390A
4	1026475	Bearing Cup, 394A
5	1041291	Seal f/ 1.50" Input Shaft
6	1041292	Seal f/ 2.00" Output Shaft
*	1001438	Vent Plug, 3/8" NPT
* Not Shown		



Hutchinson/Mayrath

A Division of GLOBAL Industries Inc.

Hutchinson/Mayrath • P.O. Box 629 • Clay Center, KS. 67432
Ph. 785-632-2161 • Fx. 785-632-5964 • Toll Free 800-523-6993
www.hutchinson-mayrath.com