

# PARTS LIST FOR TRAC-MASSTER

## OWNER'S & OPERATOR'S MANUAL

Effective February 3, 2011

Publication No. 1022405

THIS MANUAL IS FOR UNITS WITH SERIAL NUMBERS OF 912647 OR HIGHER

**HUTCHINSON  MAYRATH **

Hutchinson | Mayrath • P.O. Box 629 • Clay Center, KS. USA 67432

P 785.632.2161 • F 785.632.5964 • TF 800.523.6993

[hutchinson-mayrath.com](http://hutchinson-mayrath.com)

[aggrowth.com](http://aggrowth.com) |

**AGI** 

# **HUTCHINSON | MAYRATH**

## **POLICIES and PROCEDURES**

**Prices:** Prices in effect at time of shipment will apply. Prices are subject to change without notice. All prices are F.O.B. Clay Center, Kansas. Orders shipped from locations other than Clay Center, Kansas will be subject to additional charges, such as back freight and/or additional freight.

**Service Charge:** A service charge will be assessed for all past due balances as permitted by state law not to exceed 1-1/2% per month.

**Minimum Order:** Processing and handling costs necessitate a minimum charge of \$15.00 net on all orders.

**Back Orders:** Back orders will be shipped as they become available. Contact Hutchinson,Mayrath Customer Service for alternative shipping options or if cancellation is desired.

**Damaged Goods:** It is the consignee's responsibility to check all shipments thoroughly upon receipt of goods. If any damage is discovered, it must be noted on the freight bill of lading before signing. The consignee must make necessary claims against the respective freight line. All damage claims must be submitted within 30 days of delivery receipt.

**Shortages:** All shortages must be noted at time of delivery. Shortages must be noted on the freight bill of lading before signing. Hutchinson,Mayrath must be advised of all concealed shortages upon discovery. Once notified of concealed shortages Hutchinson,Mayrath will advise corrective action to be taken.

**Return of Goods:** All returns must be approved by Hutchinson,Mayrath prior to shipment. All return requests will be issued a return authorization number. **NO RETURNS WILL BE ACCEPTED WITHOUT A RETURN AUTHORIZATION NUMBER AND PRIOR AUTHORIZATION FROM THE FACTORY.** All returns must be shipped prepaid. A 15% restocking charge will be applied to all returned merchandise. Custom Products may not be returned for credit. Only current products in new and salable condition may be returned. No safety devices may be returned for credit.

**Modifications:** It is the policy of Hutchinson,Mayrath to improve its product whenever possible and practical to do so. We reserve the right to make changes, improvements and modifications at any time without incurring the obligation to make such changes, improvements and modifications on any equipment sold previously.

**Limited Warranty:** (a) For a period of (1) year after receipt of goods by the original consumer buyer, Hutchinson,Mayrath will supply free of charge replacement parts for parts that prove defective in workmanship or material. Defective parts must be returned freight prepaid to a specified Hutchinson,Mayrath location. Only Hutchinson,Mayrath original repair parts may be used for warranty repairs.

(b) This limited warranty does not extend to parts designed to wear in normal operation and be replaced periodically; or to damage caused by negligence, accident, abuse or improper installation or operation.

(c) **GOODS NOT MANUFACTURED BY HUTCHINSON,MAYRATH CARRY ONLY THE MANUFACTURER'S WARRANTY.**

(d) **THIS UNDERTAKING IS IN LIEU OF ALL OTHER WARRANTIES, EXPRESSED OR IMPLIED, INCLUDING MERCHANTABILITY AND FITNESS FOR A PARTICULAR PURPOSE.**

**FAILURE TO FOLLOW THE INSTRUCTIONS CONTAINED IN THE OWNER'S & OPERATOR'S MANUALS AND THE ITEMS LISTED BELOW WILL RESULT IN THE VOIDING OF THIS LIMITED WARRANTY.**

(1) Improper assembly, including failure to properly install all safety equipment.

(2) Improper installation.

(3) Unauthorized alternations of goods.

(4) Goods operated when obviously in need of repair.

(5) Use of unauthorized repair parts.

(6) Irresponsible operation.

(7) Used to handle materials other than free flowing, nonabrasive and dry materials, as intended.

(8) Damaged through abusive use or accident.

**Limitation of Liability:** BUYER AGREES THAT IN NO EVENT SHALL HUTCHINSON,MAYRATH HAVE LIABILITY FOR DIRECT DAMAGES IN EXCESS OF THE CONTRACT PRICE OF THE GOODS IN RESPECT OF WHICH CLAIM IS MADE. BUYER FURTHER AGREES THAT IN NO EVENT SHALL HUTCHINSON,MAYRATH ON ANY CLAIM OF ANY KIND HAVE LIABILITY FOR LOSS OF USE, LOSS OF PROFITS, OR FOR ANY INDIRECT, INCIDENTAL OR CONSEQUENTIAL DAMAGES.

## TABLE OF CONTENTS

Drive Shaft & Hitch Components .....	2
Hopper Flight Components .....	3
Trunk Section .....	4
Undercarriage Components .....	5-6
Head Components .....	7
Chain & Paddle .....	8
Safety & Maintenance Decals .....	9
Input Driveline Breakdown .....	10
Gearbox Breakdown .....	11-12
Hydraulic Cylinder Breakdown .....	13

## SERIAL NUMBER

To ensure efficient and prompt service, please furnish us with the model and serial number of your Trac-Masster in all correspondence or other contact. The serial plate is located on the intake hopper frame crossmember of the left side.

## SAFETY EQUIPMENT

Please remember safety equipment provides important protection for persons around a Trac-Masster that is in operation. Be sure that **ALL** safety shields and protection devices are installed and properly maintained. If you find any shields or guards damaged or missing, contact your local dealer to obtain the correct items.

# PARTS LIST

## DRIVE SHAFT & HITCH COMPONENTS

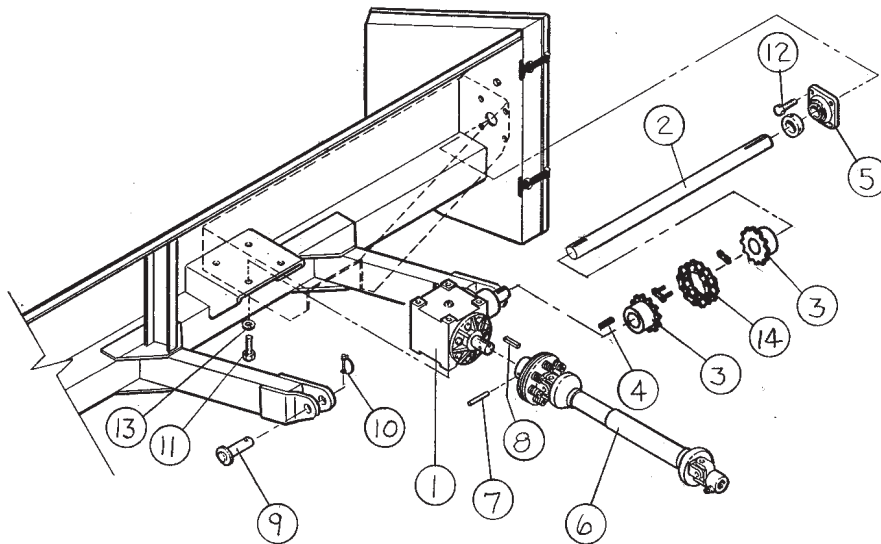

REF. NO.	PART NO.	DESCRIPTION
1	1018914	Gearbox (See pages 11 & 12 for breakdown)
2	1022078	Drive Shaft
3	1022080	Coupler Half, RC80-12T
4	1038D	3/8" x 2" Sq. Key
5	1010A	1 1/2" 4-Hole Flange Bearing
6	1016538	PTO Driveline (See page 10 for breakdown)
7	33190	5/16" x 2 1/2" Roll Pin
8	4048A1	5/16" x 2" Sq. Key
9	631236	1" Washer Head Hitch Pin
10	3093R1	1/4" x 2" Lynch Pin
11	33082	1/2" x 1" HHCS
12	33290	1/2" x 1 1/2" HHCS
13	D1143	1/2" Lock Washers
Not shown	D1169	1/2" Nut
Not shown	33157	5/16" Wing Nut
14	41051	Chain, Flex Coupler, #80 12T w/Conn. Link

### RUBBER LATCH DETAIL

REF. NO.	PART NO.	DESCRIPTION
1	41642	Rubber Handle
2	41639	Pin
3	41780	Washer
4	41638	Retaining Ring
5	41640	Anchor
6	551830	Bracket

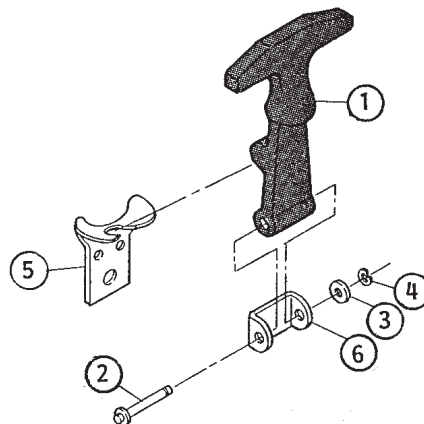

# PARTS LIST

## HOPPER FLIGHT COMPONENTS

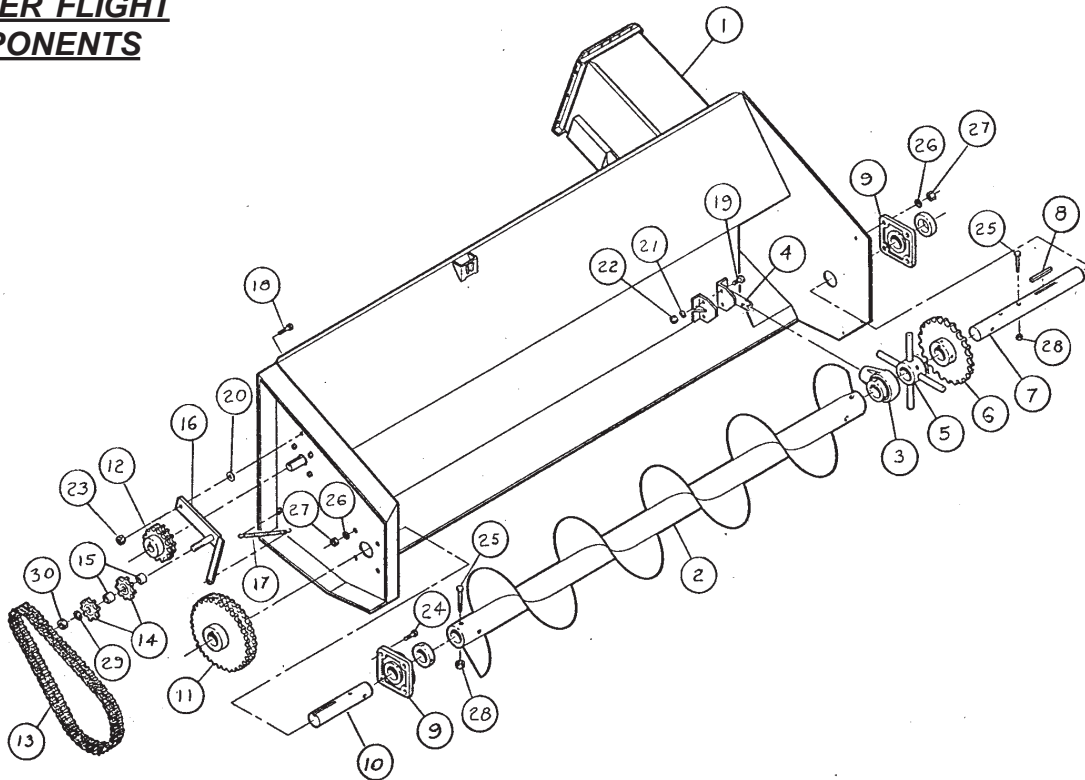

REF. NO.	PART NO.	DESCRIPTION
1	1022478	Boot Housing Weldment
2	631215	Flight Weldment
3	41053	2 7/16" Hanger Bearing
4	631212	Hanger Bearing Mount
5	631294	Spoked Wheel
6	420065	16 Tooth Sprocket w/2 7/16" Bore
7	553229	Boot Shaft
8	53060	5/8" Sq. Key x 3 3/4" Ig.
9	3090L1	2-7/16" - 4-Hole Flange Bearing
10	553230	Drive Stub
11	420110	45 Tooth Double 80 Sprocket w/2-7/16" Bore
12	40210	19 Tooth Double 80 Sprocket w/1-1/2" Bore
13	553373	72 Pitch of Double 8 Chain w/Connecting Link
14	40953	#80 Idler Sprocket
15	553242	Idler Spacer Bushings
16	631214	Idler Arm
17	6823P	Idler Spring
18	33290	1/2" x 1-1/2" HHCS
19	33082	1/2" x 1-1/4" HHCS
20	33025	1/2" Flat Washer
21	D1143	1/2" Lock Washer
22	D1169	1/2" Nut
23	33138	1/2" Lock Nut
24	D1144	5/8" x 2" HHCS
25	33105	5/8" x 4-1/2" HHCS
26	D1171	5/8" Lock Washer
27	D1170	5/8" Nut
28	33139	5/8" Lock Nut
29	D1153	3/4" Lock Washer
30	D1152	3/4" Nut

# PARTS LIST

## TRUNK SECTION

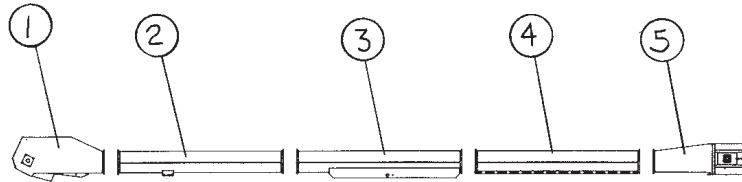

**40' MODEL**

REF. NO.	PART NO.	DESCRIPTION
1	1022082	Complete Boot Hopper w/Assembly (w/Flight, Drive Shaft, Sprocket, Gearbox, Pulley and Belt) NOTE: See page 3 for breakdown of Hopper Components
2	1005740	1st 10'-0" long Trunk Section with Lower Undercarriage Mount used on 40' & 50' unit
3	1005741	2nd 10'-0" long Trunk Section with Lift Arm Mount used on 40' & 50' unit
4	1005742	3rd 10'-0" long Trunk Section used on 40' & 50' unit
5	1005739	Complete Head Section Assembly w/Sprocket, Bearings and Take-up Slide NOTE: See page 7 for Head Components

## UNDERCARRIAGE COMPONENTS

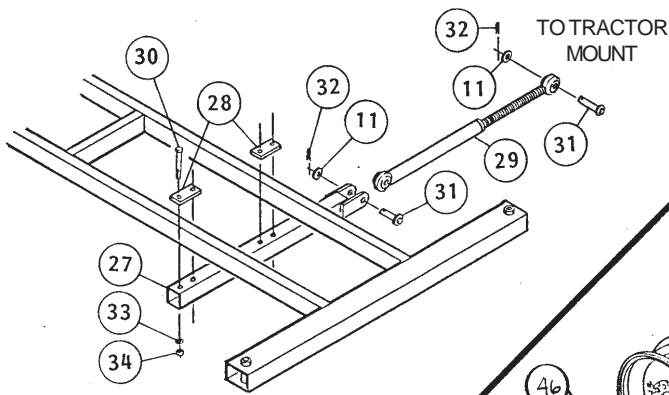
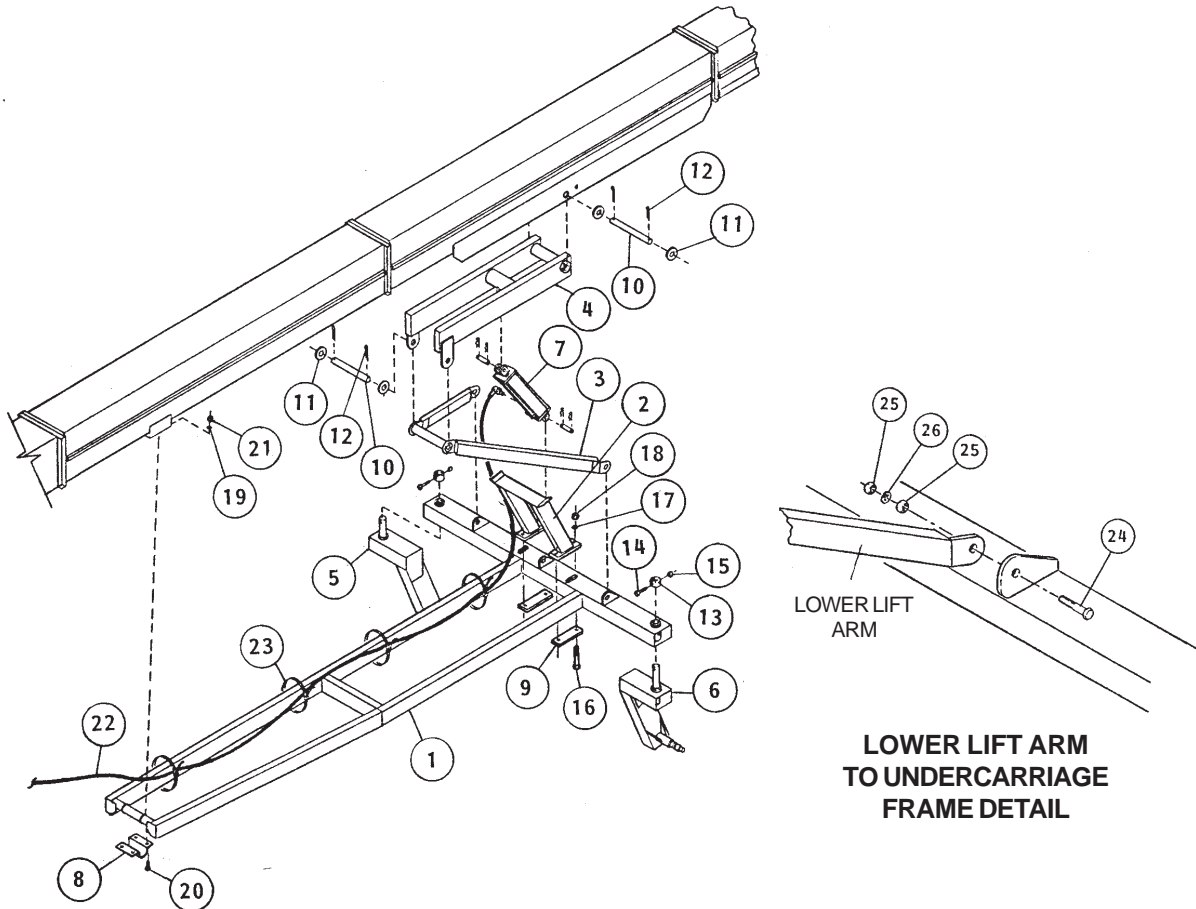

**FRONT ATTACHMENT COMPONENTS**

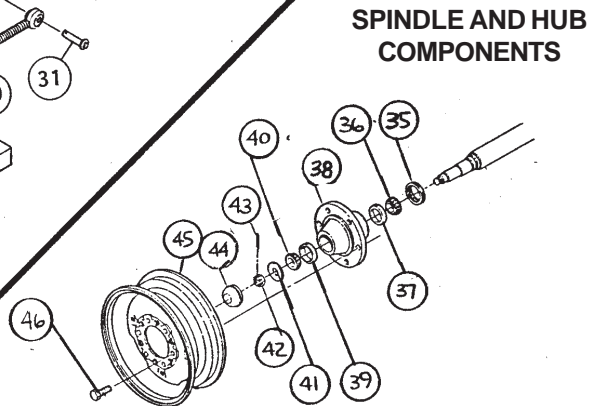

**SPINDLE AND HUB COMPONENTS**

# PARTS LIST

## UNDERCARRIAGE COMPONENTS

REF. NO.	PART NO.	DESCRIPTION
1	130236	Undercarriage Frame Weldment (150" long x 84" wide)
2	631293	Transport Rest Weldment
3	130237	Lower Lift Arm Weldment
4	130238	Upper Lift Arm Weldment
4	631230	Castor Weldment
6	631231	Castor Weldment
7	1004368	Hydraulic Cylinder 3-1/2" dia. x 24" stroke (See page 13 for parts) (1-1/2" dia rod, 1" dia. mounting clevis w/vent plug)
8	8387D	Lower Undercarriage Clamp
9	553456	Clamp Plate for Transport Rest (3" x 9")
10	553297	Pin 1" x 15 3/8" long
11	D1160	Flat Washer 1" I.D.
12	D1263	Cotter Pin 1/4" x 2" long
13	553244	Lock Collar 2" I.D. x 2 7/16" O.D. x 1-1/2" long
14	33091	Bolt 1/2" x 3" long (Grade 5)
15	33138	Lock Nut 1/2"
16	33116	Bolt 3/4" x 6" long (Grade 5)
17	D1153	Lock Washer 3/4"
18	D1152	Nut (non-lock) 3/4"
19	D1143	Lock Washer 1/2"
20	33247	Bolt 1/2" x 1-3/4" long (Grade 5)
21	D1169	Nut (non-lock) 1/2"
22	1002699	Hydraulic Hose 1/2" x 25'-0" long with 90° elbow end w/restrictor
23	40310	Plastic Tie-down
24	631255	Bolt 1" x 4" long
25	D1158	Nut (non-lock) 1"
26	D1159	Lock Washer 1"
27	631233	Attachment Arm 42 1/2" long
28	553279	Clamp Plate for Attachment Arm 2-1/2" x 5"
29	631232	Attach Arm Turnbuckle
30	33280	Bolt 5/8" x 9" long
31	631236	Headed Pin 1" x 5-5/16" Overall Length
32	3093R1	Lynch Pin 1/4" x 2" long
33	D1171	Lock Washer 5/8"
34	D1170	Nut (non-lock) 5/8"
35	D1072	Grease Seal
36	3078R1	Inner Cone (LM48548)
37	3147R1	Inner Cup (LM48510)
38	D1251	6-Bolt Hub (includes cups, Ref. No's 37 & 39)
39	3148R1	Outer Cup (LM67010)
40	3079R1	Outer Cone (LM67048)
41	D1148	7/8" Washer
42	D1147	7/8" Slotted Hex Nut
43	D1146	5/32" x 1-1/4" Cotter Pin
44	40588	Hub Cap
45	D1252	15" x 6" LB 6-Bolt Wheel
46	D1077	Lug Bolt

# PARTS LIST

## HEAD SECTION

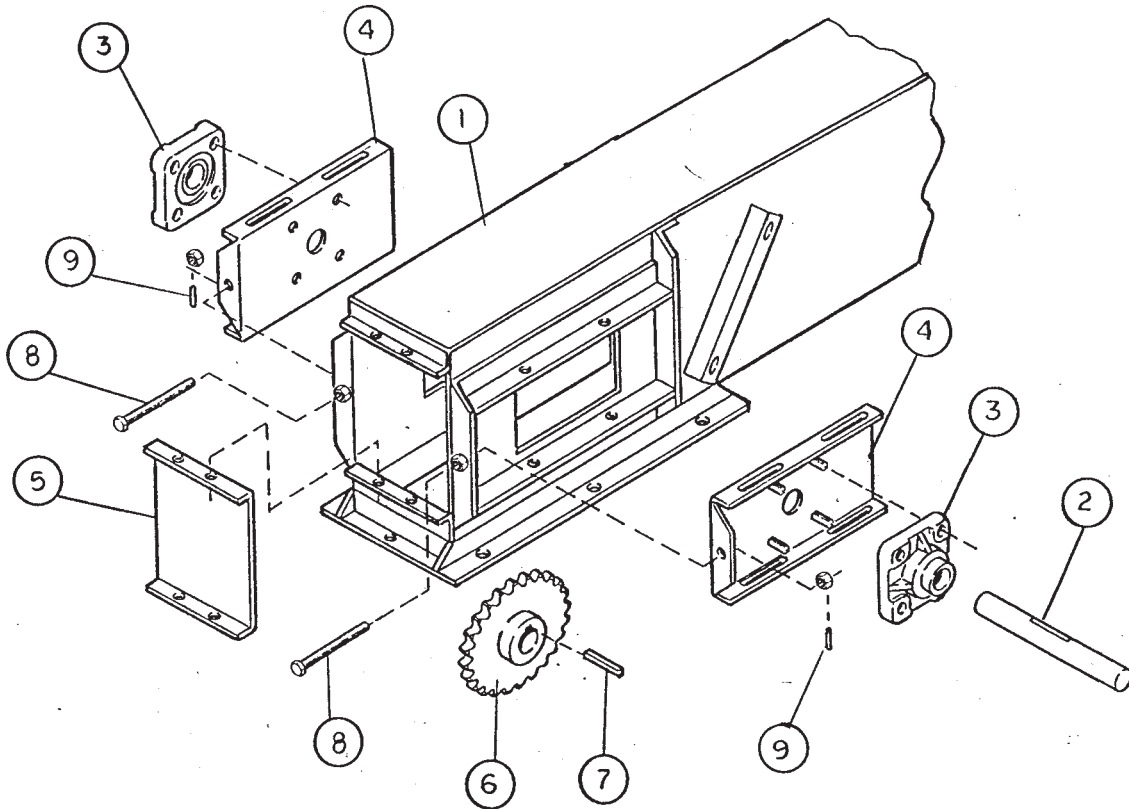

REF. NO.	PART NO.	DESCRIPTION
1	1003830	Head Section Weldment (Includes Door, item no. 5)
2	553276	Head Shaft 2-7/16" x 19-3/8" long (Turn down to 2" on the ends)
3	2214C	2" Bore 4-Hole Flange Bearing
4	61223	Take-up Slide
5	50609	Inspection Door
6	420065	16 Tooth 81 Sprocket 2-7/16" Bore
7	53060	Drive Key 5/8" x 3-3/4"
8	61147	Take-up Bolt w/two nuts
9	31121	Roll Pin 3/16" x 1" long

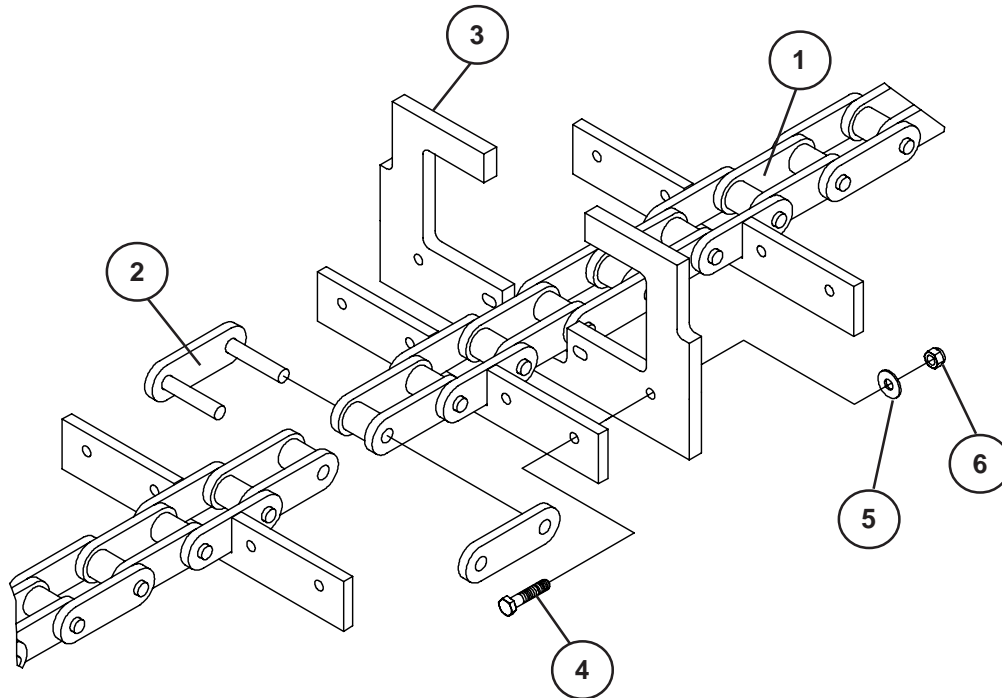
**PARTS LIST****CHAIN & PADDLE**

REF. NO.	PART NO.	DESCRIPTION
1	1038009	Chain 81XHH Roll of 10'-2 7/32" long (48 pitches)
2	1017077	Connecting Link for 81XHH Chain
3	1005588	1/2" Thick Model 85 Plastic Paddle (98 used on 40' Model) (122 used on 50' Model)
4	4736	Bolt 5/16" x 1-1/2" (Grade 5)
5	33023	Flat Washer 5/16"
6	33135	Lock Nut 5/16"
*	1034495	Chain Half Link, f/81XHH Chain

\*Not Shown

## SAFETY AND MAINTENANCE SIGNS

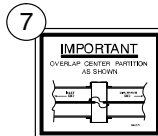
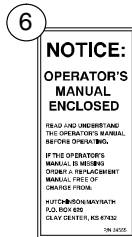
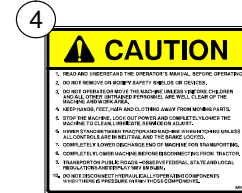
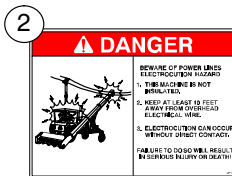
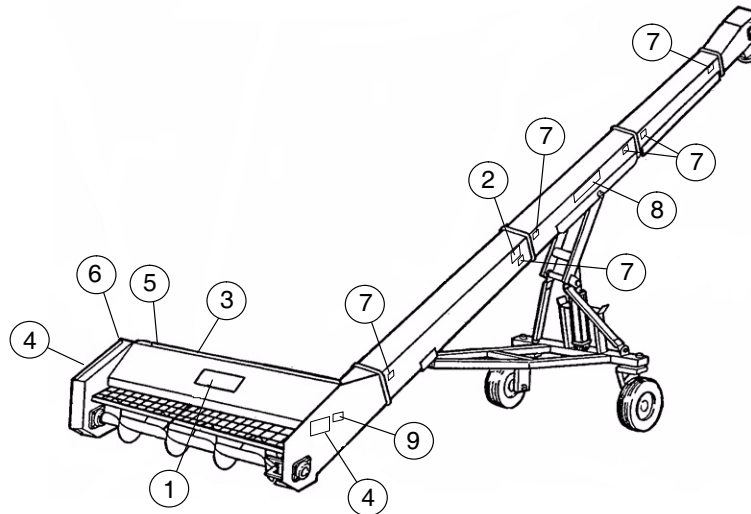

Ref. No.	Part No.	Description
1	34549	Decal: Danger, Keep Away from Rotating Auger...(lrg.)
2	34547	Decal: Danger, Beware of Power Lines
3	1001983	Decal: Rotating Driveline
4	34550	Decal, Caution: General Information
5	34548	Decal: Danger, Keep Away from Rotating Auger...(smll.)
6	34555	Decal: Notice. Operator's Manual Inside
7	34221	Decal, Trunk Alignment
8	1001127	Decal: Hutchinson (49 1/8" long)
9	1041833	Decal: Made in the Heart of America

# PARTS LIST

## PTO DRIVELINE COMPONENTS

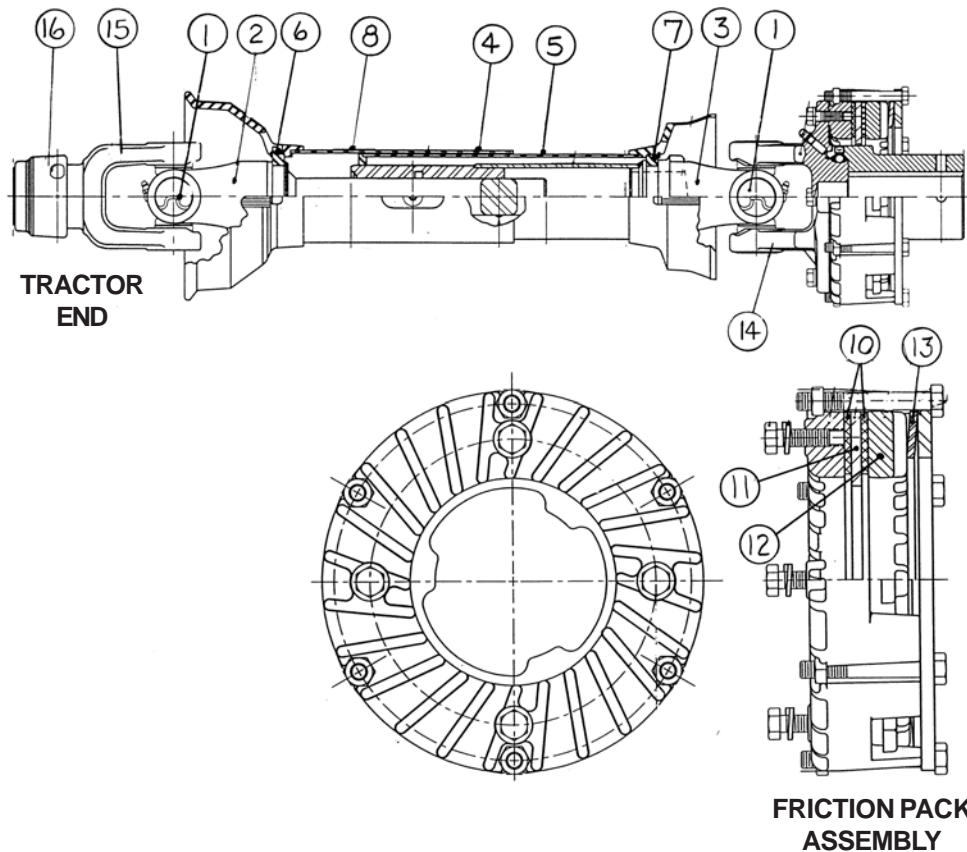

REF. NO.	WEASLER PART NO.	HUTCHINSON/ MAYRATH PART NO.	DESCRIPTION
--	242-11813	1016538	PTO Driveline Assembly w/Clutch
--	38-50014	1023535	Clutch Friction Pack Assembly, 9,000 IN-LB
1	03-10045S	1010563	35R Cross and Bearing Kit
2	93-11813	1022487	Joint and Shaft Half Assembly with Guard
3	92-11813	1022488	Joint and Tube Half Assembly with Guard
4	97-11813	420172	Outer Guard
5	96-11813	420173	Inner Guard
6	19-11104	1010565	Nylon Repair Kit
7	19-11105	1026020	Nylon Repair Kit
8	13-10021	13-10021	Safety Sign
9	13-10022	13-10022	Safety Sign
10	11-11167	1022470	Friction Disc
11	20-15133	1022471	Separator Plate
12	80311-1000	1022472	Pressure Plate
13	23-15039	1023534	Spring
14	38-60016	1022486	Yoke & Free Motion Hub
15	35031-1015	1022491	Safety Slide Yoke Assembly
16	26-15120	1010561	Safety Slide Lock Repair Kit

# PARTS LIST

## GEARBOX COMPONENTS - 1018914

Shown below is a breakdown for Gearbox 1028914 used on current Trac-Masster starting with Serial Number 438549.

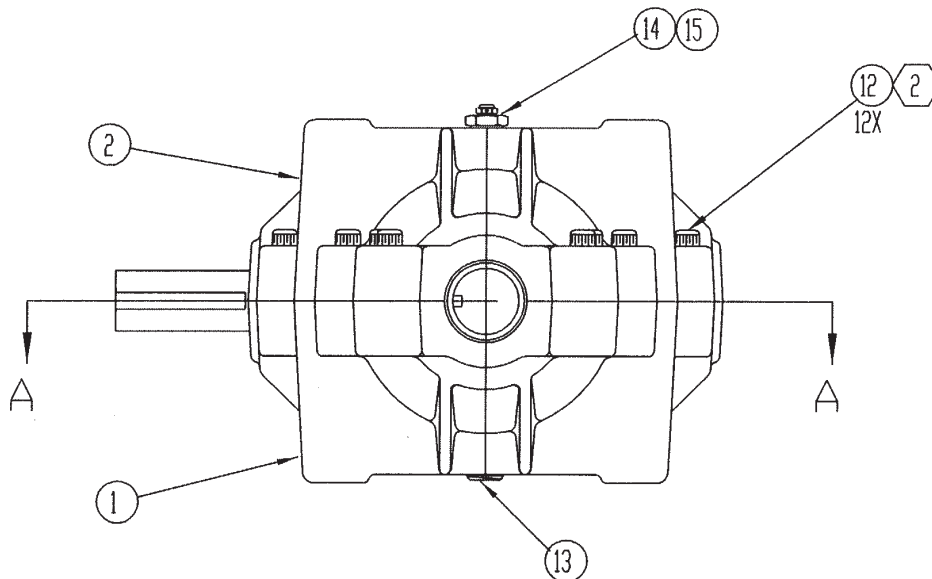
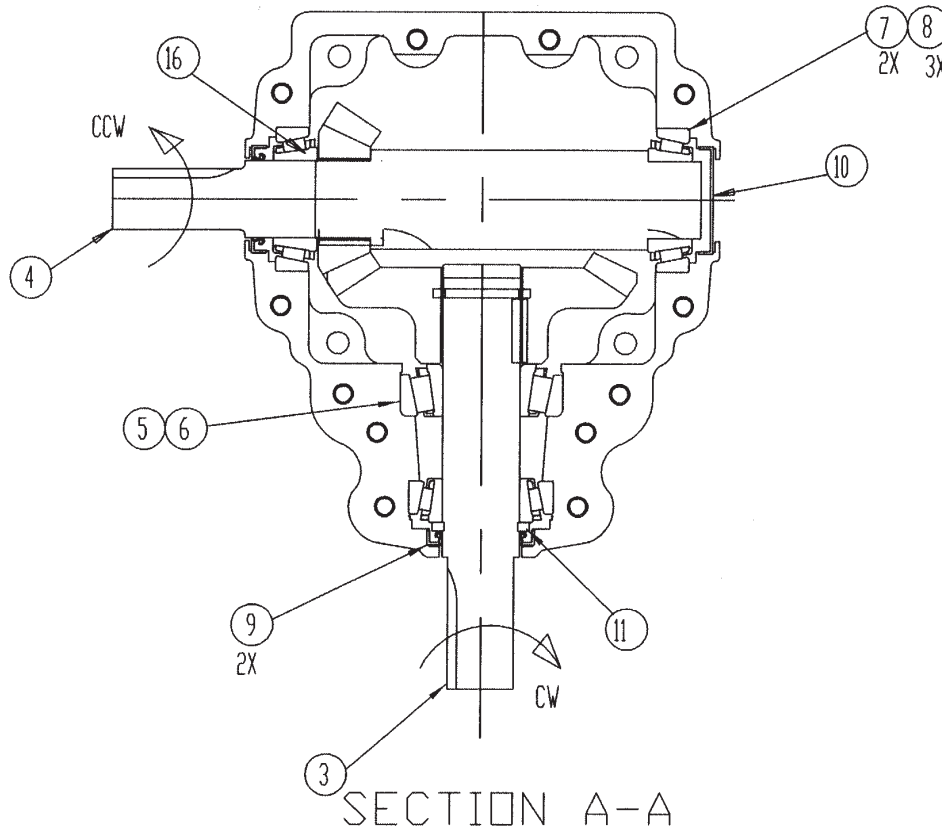

**NOTE: Gearbox oil capacity is 85 oz. of EP 80/90.**

**PARTS LIST****GEARBOX COMPONENTS - 1018914**

Use on current Trac-Master Conveyor starting  
with Serial Number 428549.

REF. NO.	SUPERIOR GEARBOX PART NO.	HUTCHINSON/ MAYRATH PART NO.	DESCRIPTION
1	600003006104	1022439	Housing Half
2	600004006105	1022440	Housing Half
3	R600-8B00-A0388	1022441	Gear and Shaft Assembly
4	R600-8B00-A0389	1022442	Gear and Shaft Assembly
5	603782	1022443	Bearing Cone
6	603720	1022444	Bearing Cup
7	625581	1022445	Bearing Cone
8	625520	1022446	Bearing Cup
9	617285	1022447	Seal
10	600301	1022448	End Cap
11	603493	1022449	Retaining Ring
12	438225	1006232	Bolt, 3/8 - 16 x 2-1/4" SH
13	400300	1022453	Plug, 1/2 - 14 NPT
14	4003VB	1022452	Bushing, 1/2" NPT to 1/8 NPT
15	2003PR	1022451	Vent Plug, 5 PSI
16	625580	1022450	Bearing Cone

## HYDRAULIC CYLINDER COMPONENTS

### PARTS LIST FOR CYLINDER NO. 420027

3-1/2" Bore x 24" Stroke with  
1" Dia. Mounting Pins,  
1-1/2" Dia. Piston Rod,  
3/4 -16 SAE #8 Straight  
Threads O-Ring Ports

**IMPORTANT:**  
The cylinder was manufactured  
by Cross Mfg., Inc.  
Lewis, KS.

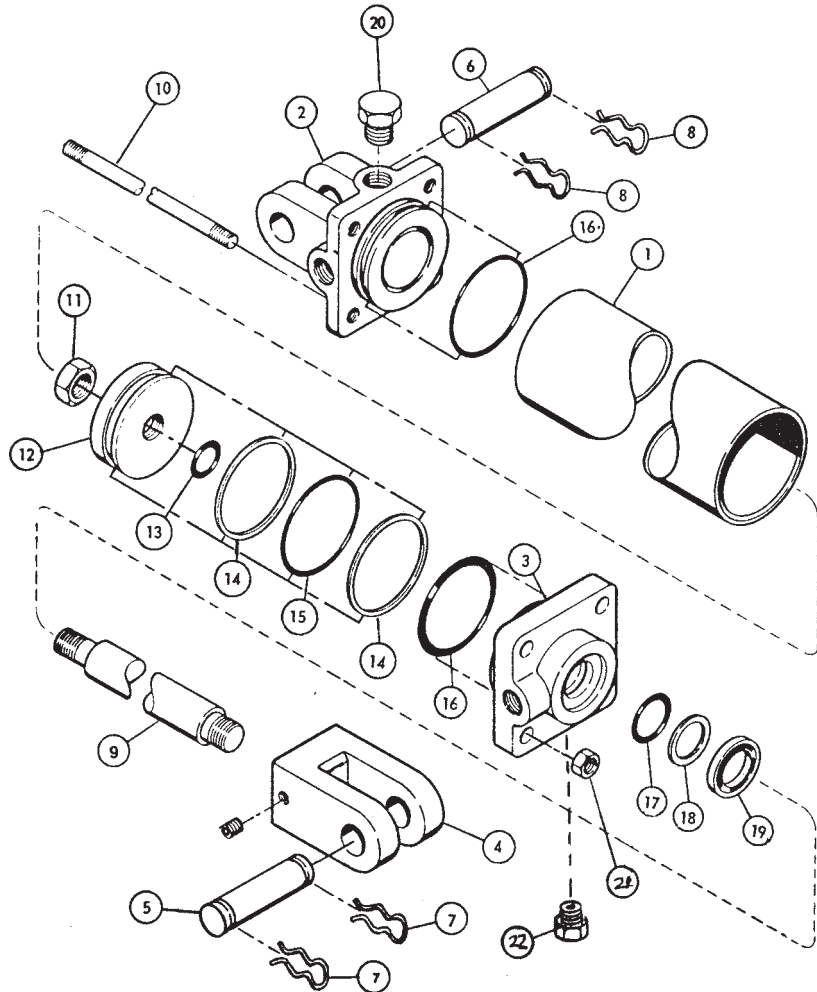

REF. NO.	HUTCHINSON/ MAYRATH PART NO.	CROSS PART NO.	DESCRIPTION
0	420159	1C4631	Seal kit for 3-1/2" x 24" DB Cross Cylinder
1	420199	1D0009-2650	Housing 3-1/2" x 24" DB Cross Cylinder
2	420188	1D1509-8	Base Clevis
3	420194	1D1159-17	Head Gland
4	420197	3C4559	Clevis Assembly
5 & 6	420183	1D1582-16300	Clevis Pin
7 & 8	41222	2A0308-1	Spring Clip
9	420198	1D0222-2862	Piston Rod 1 3/4" Dia.
10	420196	2A0581-2925	Tie Rod
11	420187	1A1141	Piston Nut
12	420189	1D1401-350	Piston
13			O-Ring
14	Available in		Piston Back-up Washer
15	Seal Kits		O-ring, (large)
16	Only		O-ring, (large)
17			O-ring, Base
18			Base, Back-up Washer
19			Wiper Seal
20	420184	2A0354-112	Solid Plug
21	420195	2A0236-9	Nut for Tie Rod
22	420034	--	Vent Plug

# **HUTCHINSON MAYRATH**

MANUFACTURED BY  
**HUTCHINSON | MAYRATH**

P.O. Box 629, 514 W. Crawford Street    **TF** 800.523.6993  
Clay Center, Kansas                      **P** 785.632.2161  
USA 67432                                      **F** 785.632.5964

**[hutchinson-mayrath.com](http://hutchinson-mayrath.com)**