

# MODEL 50 & MODEL 85 STATIONARY MASS-TER MOVER

## OWNER'S & OPERATOR'S MANUAL

Effective January 13, 2016

Publication No. 1039421

This manual is for units with Serial No's. 953499 and higher.

**IMPORTANT!** The gearbox is shipped **Without Oil**.  
***Oil must be added before operation.***  
Refer to the Lubrication Section in this manual.



***Hutchinson/Mayrath***

*A Division of GLOBAL Industries Inc.*

Hutchinson/Mayrath • P.O. Box 629 • Clay Center, KS. 67432  
Ph. 785-632-2161 • Fx. 785-632-5964 • Toll Free 800-523-6993  
[www.hutchinson-mayrath.com](http://www.hutchinson-mayrath.com)



## **Hutchinson/Mayrath**

A Division of **GLOBAL** Industries, Inc.

### **POLICIES AND PROCEDURES**

- Prices:** Prices in effect at time of shipment will apply. Prices are subject to change without notice. All prices are F.O.B. Clay Center, Kansas. Orders shipped from locations other than Clay Center, Kansas will be subject to additional charges, such as back freight and/or additional freight.
- Service Charge:** A service charge will be assessed for all past due balances as permitted by state law not to exceed 1-1/2% per month.
- Minimum Order:** Processing and handling costs necessitate a minimum charge of \$15.00 net on all orders.
- Back Orders:** Back orders will be shipped as they become available. Contact Hutchinson/Mayrath Customer Service for alternative shipping options or if cancellation is desired.
- Damaged Goods:** It is the consignee's responsibility to check all shipments thoroughly upon receipt of goods. If any damage is discovered, it must be noted on the freight bill of lading before signing. The consignee must make necessary claims against the respective freight line. All damage claims must be submitted within 30 days of delivery receipt.
- Shortages:** All shortages must be noted at time of delivery. Shortages must be noted on the freight bill of lading before signing. Hutchinson/Mayrath must be advised of all concealed shortages upon discovery. Once notified of concealed shortages Hutchinson/Mayrath will advise corrective action to be taken.
- Return of Goods:** All returns must be approved by Hutchinson/Mayrath prior to shipment. All return requests will be issued a return authorization number. **NO RETURNS WILL BE ACCEPTED WITHOUT A RETURN AUTHORIZATION NUMBER AND PRIOR AUTHORIZATION FROM THE FACTORY.** All returns must be shipped prepaid. A 15% restocking charge will be applied to all returned merchandise. Custom Products may not be returned for credit. Only current products in new and salable condition may be returned. No safety devices may be returned for credit.
- Modifications:** It is the policy of Hutchinson/Mayrath to improve its product whenever possible and practical to do so. We reserve the right to make changes, improvements and modifications at any time without incurring the obligation to make such changes, improvements and modifications on any equipment sold previously.
- Limited Warranty:**
- (a) For a period of (1) year after receipt of goods by the original consumer buyer, Hutchinson/Mayrath will supply free of charge replacement parts for parts that prove defective in workmanship or material. Defective parts must be returned freight prepaid to a specified Hutchinson/Mayrath location. Only Hutchinson/Mayrath original repair parts may be used for warranty repairs.
  - (b) This limited warranty does not extend to parts designed to wear in normal operation and be replaced periodically; or to damage caused by negligence, accident, abuse or improper installation or operation.
  - (c) **GOODS NOT MANUFACTURED BY HUTCHINSON/MAYRATH CARRY ONLY THE MANUFACTURER'S WARRANTY.**
  - (d) **THIS UNDERTAKING IS IN LIEU OF ALL OTHER WARRANTIES, EXPRESSED OR IMPLIED, INCLUDING MERCHANTABILITY AND FITNESS FOR A PARTICULAR PURPOSE.**
- FAILURE TO FOLLOW THE INSTRUCTIONS CONTAINED IN THE OWNER'S & OPERATOR'S MANUALS AND THE ITEMS LISTED BELOW WILL RESULT IN THE VOIDING OF THIS LIMITED WARRANTY.**
- (1) Improper assembly, including failure to properly install all safety equipment.
  - (2) Improper installation.
  - (3) Unauthorized alternations of goods.
  - (4) Goods operated when obviously in need of repair.
  - (5) Use of unauthorized repair parts.
  - (6) Irresponsible operation.
  - (7) Used to handle materials other than free flowing, nonabrasive and dry materials, as intended.
  - (8) Damaged through abusive use or accident.
- Limitation of Liability:** BUYER AGREES THAT IN NO EVENT SHALL HUTCHINSON/MAYRATH HAVE LIABILITY FOR DIRECT DAMAGES THE EXCESS OF THE CONTRACT PRICE OF THE GOODS IN RESPECT OF WHICH CLAIM IS MADE. BUYER FURTHER AGREES THAT IN NO EVENT SHALL HUTCHINSON/MAYRATH ON ANY CLAIM OF ANY KIND HAVE LIABILITY FOR LOSS OF USE, LOSS OF PROFITS, OR FOR ANY INDIRECT, INCIDENTAL OR CONSEQUENTIAL DAMAGES.

# TABLE OF CONTENTS

<b>POLICIES AND PROCEDURES</b> .....	<b>(Inside Front Cover)</b>
<b>TABLE OF CONTENTS</b> .....	<b>1</b>
<b>SAFETY</b> .....	<b>2 - 4</b>
General Safety Statement, Safety Alert Symbol .....	2
Safety Information (Emergencies, PPE, Grain Bin Safety, etc.) .....	2-4
Safety Decals .....	4
<b>GENERAL INFORMATION</b> .....	<b>5 - 9</b>
Operator Qualifications .....	5
Sign-Off Sheet .....	5
Machine Inspection .....	6
Start-Up & Break-In Information .....	6
Designated Work Area .....	6
Electric Motor Drive Information .....	7
Full Load Operation Information .....	7
Drive Power Calculation .....	8-9
<b>OPERATING PROCEDURES</b> .....	<b>10</b>
Conveyor Operating Procedures .....	10
Shutdown/Lockout .....	10
<b>LUBRICATION &amp; MAINTENANCE</b> .....	<b>11 - 13</b>
General Maintenance Information .....	11
Conveyor Chain .....	11
Gear Reducer .....	12
Bearing Lubrication .....	12-13
Drive Belts .....	13
Trouble Shooting .....	13
<b>ASSEMBLY INSTRUCTIONS</b> .....	<b>14 - 27</b>
Layout and Design .....	14
Conveyor Capacities .....	14
Inlet Information .....	14
Truss Information .....	14
Trunking Assembly .....	15-16
Chain and Paddle Assembly .....	17-18
Head Drive Assembly .....	19
Truss Assembly .....	20-21
Inlet Assemblies .....	22-26
Outlets Assemblies .....	26-27
<b>PARTS LIST TABLE OF CONTENT</b> .....	<b>28</b>
<b>PARTS LIST</b> .....	<b>P-1 - P-71</b>
<b>TORQUE CHART</b> .....	<b>P-72</b>

# SAFETY

## **GENERAL SAFETY STATEMENT**

This manual was written with the safety of the operator and others who work with the equipment as our prime concern. The instructions presented will help the reader learn **SAFE** day to day work practices. We want you as our partner in safety.

It is your responsibility as an owner, operator or supervisor to know what specific safety requirements and precautions exist and to make these known to all other personnel working with the equipment or in the area, so that they too may safely perform their duties and avoid any potentially hazardous situations.

**We suggest the implementation of a Safety Program for all personnel that includes, but is not limited to, the proper use of PPE (personal protective equipment), Fall Protection Systems and Lock Out-Tag Out procedures.**

Please remember safety equipment provides important protection for persons around a grain handling system that is in operation. Be sure **ALL** safety shields and protection devices are installed and properly maintained. If any shields or guards are damaged or missing, contact your dealer to obtain the correct items.

Avoid any alterations of the equipment. Such alterations may create a dangerous situation where serious injury or death may occur.

## **SAFETY ALERT SYMBOL**

**The safety symbol shown is used throughout this manual to alert you to information about unsafe actions or situations, and will be followed by the word DANGER, WARNING, or CAUTION.**

**DANGER** - Indicates immediate hazards that may result in severe injury or death. **WARNING** - Indicates unsafe actions or situations that may cause severe injury, death and/or major equipment or property damage. **CAUTION** - Indicates unsafe actions or situations that may cause injury, and/or minor property damage.

Watch this symbol - it points out important safety precautions. It means - **ATTENTION! Become alert! Your safety and the safety of others is involved!** Read the message that follows the symbol when a warning is given, be alert to the possibility of personal injury or death.



### **Follow Safety Instructions**

Carefully read all safety messages in this manual and safety signs on your machine. Check to ensure all Safety Decals are present and in good condition.

If a decal cannot easily be read for any reason, or has been painted over, replace the decal immediately. Safety decals are offered free of charge, and can be ordered through your Hutchinson/Mayrath dealer or directly from the factory.

Learn how to operate the machine and how to use controls properly.

Keep your machinery in proper working condition. Understand service procedures before doing work. Never lubricate, service or adjust machine while it is in operation.

Keep work area clean, dry and free from of all debris and tools which may cause accidental tripping or falling.



**Read and Understand Manual**

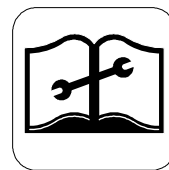

**Understand Service Procedures**



**Keep Work Area Clean**

### **Prepare for Emergencies**

Keep emergency numbers for doctors, ambulance service, hospital and fire department near your telephone.

Keep a first-aid kit and fire extinguisher handy.

Be prepared if a fire starts

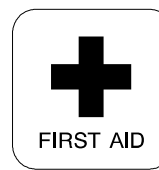

**First Aid Equipment**



**Fire Extinguisher**

## **Wear Proper PPE (Personal Protective Equipment)**

Some materials can create flying debris when they are filed, cut or drilled. Safety glasses should be worn at all times to protect your eyes from such debris.

Hearing protection should be worn when operating power tools or other power equipment that could be harmful to your hearing.

Gloves should be worn to protect your hands from sharp metal and plastic edges, as well as providing protection from the handling of heavy objects.

Wear steel toe boots to protect your feet from falling debris.

Wear a hard hat to help protect your head from falling objects as well as from accidental bumping.

Use caution when working at elevations greater than four (4) feet (1.22 m) above the ground.

Use the appropriate fall protection equipment as set forth by OSHA guidelines and regulations.

A respirator may be needed to prevent breathing potentially toxic fumes and dust, especially when working within a grain bin or storage structure.

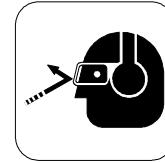

Eye & Hearing Protection



Gloves



Steel Toe Boots



Hard Hat



Fall Protection

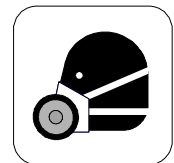

Respirator

## **Operate Electric Motor(s) Properly**

Do not operate electric motor equipped units until motor(s) are properly grounded.

Know how to "Shutdown and Lockout" the power source. Shutdown and lockout power source before performing any service, maintenance or adjustments to the unit.

Disconnect power on electrical driven units before resetting motor overloads.

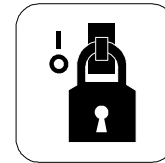

Lockout / Tagout



Electric Shock Hazard

## **Stay Clear of Moving Parts**

Keep all shields, covers and safety devices in place at all times.

Entanglement in moving chains, rotating impeller arms and sprockets will cause serious injury or death.

Wear close fitted clothing. Keep hands, feet and clothing away from moving parts.

Shutdown and lockout power source before making adjustments, cleaning or maintaining the equipment.

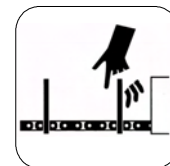

Entanglement Hazards



# SAFETY

## GRAIN BIN SAFETY

The Stationary Mass-Ter Mover System is generally designed to move grain into or from grain bins or other storage structures. **Be aware of the dangers inherent in grain bins.**

Consult the grain bin manufacturer's manual for information on the proper loading and unloading of the bins, structural stress analysis, adequate venting and important safety information.



**WARNING!** Do Not enter the bin if the grain has “Bridged” or has not flowed normally out of the bin, See Example’s 1 & 2. The grain may suddenly break loose and bury resulting in suffocation.



Do Not enter the bin unless all power driven equipment has been shut down and locked out. Never enter the bin unless monitored by another person.

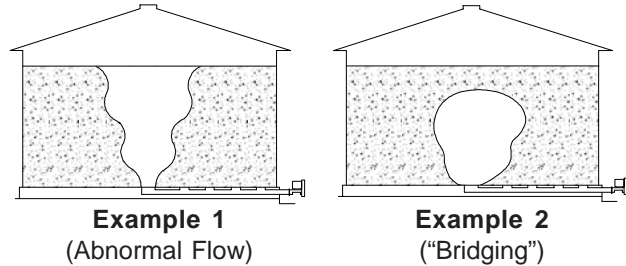

## SAFETY DECALS

Check to ensure all Safety Decals are present and in good condition. If a decal cannot easily be read for any reason, or has been painted over, replace the decal immediately. Safety decals are offered free of charge, and can be ordered through your Hutchinson/Mayrath dealer or directly from the factory.

Refer to the Parts List Section for decal Part No's. and location of decals on components.

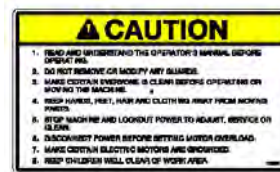

## OPERATOR QUALIFICATIONS



### **WARNING!**

Anyone who will operate or work around this machine shall first read this manual! This manual must be delivered with the equipment to its owner. Failure to read this manual and its safety instructions is a misuse of the equipment.

**Operation of this conveyor system shall be limited to competent and experienced persons. In addition, anyone who will operate or work around a conveyor must use good common sense. In order to be qualified, he must also know and meet all other requirements, such as:**

1. Some regulations specify that no one under the age of 16 may operate power machinery. This includes this conveyor. It is your responsibility to know what these regulations are in your area or situation.
2. Current OSHA regulations state in part: "At the time of initial assignment and at least annually thereafter, the employer shall instruct every employee in safe operation and servicing of all equipment with which the employee is, or will be involved." \*

3. Unqualified persons are to stay out of the work area. See Page 6.
4. A person who has not read and understood all operating and safety instructions is not qualified to operate the machine.
5. Persons operating, servicing or repairing equipment that requires above ground work shall be properly secured with the use of "fall protection" equipment as set forth by OSHA guidelines and regulations.

\*Federal Occupational Safety & Health Standards for Agriculture Subpart D, Section 1928.57 (a) (6).

## **SIGN OFF SHEET**

As a requirement of OSHA, it is necessary for the employer to train the employee in the safe operation and safety procedures with this conveyor. We include this sign off sheet for your convenience and personal record keeping.

<b><u>Training Sign-Off Sheet</u></b>		
<b>Date</b>	<b>Employer Signature</b>	<b>Employee Signature</b>

# GENERAL INFORMATION

## **MACHINE INSPECTION**

After completion of assembly and before each use, inspection of the machine is mandatory. This inspection should include, but not be limited to:

1. Inspect the conveyor for loose bolts, missing chain parts, missing or damaged paddles and the overall chain condition.
2. Check chain tension.
3. Check the condition and tension of drive belts and adjust as necessary.
4. Inspect sheaves for alignment and see that they are securely fastened.
5. Check oil level in drive reducer.
6. Check all safety signs and replace any that are worn, missing or illegible. The safety signs are listed in the front of this manual.
7. Check that all safety devices, guards and shields are installed and that all inspection doors are latched closed.

Obtain any needed replacement parts from your dealer and install before using the machine.

## **START-UP and BREAK-IN INFORMATION**



**WARNING!** During initial start-up and break-in period, the operator shall be aware of any unusual vibrations or noises that would indicate a need for service or repair.



Keep all safety shields and devices in place. Keep hands, feet, and clothing away from moving parts.



The operator should have a full view of the auger work area and check that all personnel are free from designated work areas before adding power.

It is essential to inspect your conveyor and drive components before adding power and to know how to shut down in an emergency. During the operation of your conveyor, one person shall be in a position to monitor the operation.

During the initial start-up and break-in period, the operator should watch for any unusual vibrations or noises.

Any conveyor, when it is new or after it sits idle for a season, should go through a “break-in” period. It should be run at partial capacity at full speed until the inside of the housing becomes polished, before attempting full capacity. A failure will most likely occur when it is run at full capacity before it has a chance to “shine up”.

## **START-UP and BREAK-IN INFORMATION (con't.)**

If at all possible, do not start or stop the Masster-Mover under load, especially before the housing becomes well polished, as this may cause the unit to stall.

## **DESIGNATED WORK AREA**

The area around the conveyor and inside the grain storage units is considered the work area. Use the following to ensure a safe working environment.



**WARNING!** Under no circumstances should persons not involved in the operation be allowed to trespass into the work area.

It shall be the duty of all operators to see that children and/or other persons stay out of the work area! Trespass into the work area by anyone not involved in the actual operation, or trespass into a hazard area by anyone shall result in an immediate shutdown by the operator.



It shall be the responsibility of all operators to see that the work area has secure footing, is clean and free of all debris and tools which might cause accidental tripping and/or falling. It shall also be their responsibility to keep the work area clean and orderly during the operation.



Use caution when working in areas above the ground. Persons operating, servicing or repairing equipment that requires above ground work shall be properly secured with the use of “fall protection” equipment as set forth by OSHA guidelines and regulations.



Metal buildings, scaffolding and other types of work surfaces can become slippery, especially when surfaces are wet and/or oily. This can create hazardous working conditions. Use caution when working, climbing or walking on these surfaces.

## ELECTRIC MOTOR DRIVE INFORMATION



**WARNING! A main power disconnect switch that can be locked in only the "OFF" position shall be provided. This shall be locked whenever work is being done on the conveyor.**



**The reset and starting controls must be located so that the operator has full view of the entire operation.**

**Do Not enter the grain bin unless all power driven equipment has been shut down and locked out.**

**Make certain electric motor is grounded.**



**Disconnect power before resetting motor overloads.**

**Shut off power and lockout whenever cleaning or servicing the conveyor.**

Always use a motor with required HP (kw) as calculated using the tables shown on Pages 8 or 9. Use a 60 kw motor that operates at 1750 rpm (50 hz @ 1460 rpm).

Electrical motor and controls shall be installed by a qualified electrician and must meet the standards set by the National Electrical Code and all local and state codes.

A magnetic starter should be used to protect your motor when starting and stopping. It should stop the motor in case of power interruption, conductor fault, low voltage, circuit interruption or motor overload. Then the motor must be restarted manually.

Some motors have built-in thermal overload protection. If this type motor is used, use only those with a manual reset.

Install with an ammeter on motor or motors, so that the load can always be monitored to prevent overloading.

A main power disconnect switch that can be locked only in the "Off" position shall be provided. This shall be locked whenever work is being done to the conveyor.

## FULL LOAD OPERATION INFORMATION

Operation of the Mass-ter Mover Conveyor will generally include moving grain into or out of various types of storage structures.

Grain will enter the conveyor through a dump hopper or through bin wells in grain bins. There are flow control devices included with these components that should be used to control grain flow rates into the conveyor.

## FULL LOAD OPERATION INFORMATION (con't.)

It is possible to use more than one inlet component at the same time, such as when blending is desired or simply to increase the flow rate into the conveyor.

Grain is discharged from the conveyor through outlets with movable gates for opening and closing the outlets. Optional ground controls are available for operating the gates. All gates should be closed except the one at the selected discharge point.

A sweep auger may be placed in the bin after all the grain has been removed that will gravity-flow through the center well. The grain remaining should appear as in Fig. 3. Shut down and lock out the Mass-Ter Mover before installing the sweep auger.

If intermediate bin wells are being used, they should be opened after grain has stopped flowing into the center well and before the sweep auger is placed in the bin. See Fig. 4. Shut down and lock out the Mass-Ter Mover before installing the sweep auger.



**WARNING! Do Not enter the bin if the grain has "Bridged" or has not flowed normally out of the bin, See Fig's. 1 & 2. The grain may suddenly break loose and bury resulting in suffocation.**



**Do Not enter the bin unless all power driven equipment has been shut down and locked out. Never enter the bin unless monitored by another person.**

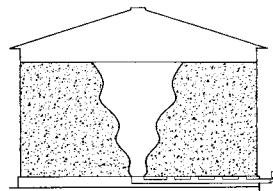

**Fig. 1**  
(Abnormal Flow)

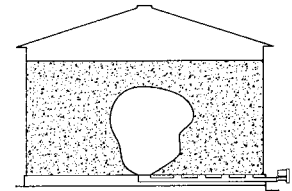

**Fig. 2**  
("Bridging")

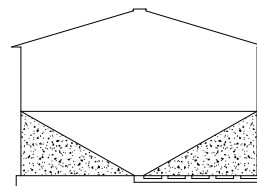

**Fig. 3**  
**Grain Flow Through Center Bin Well**

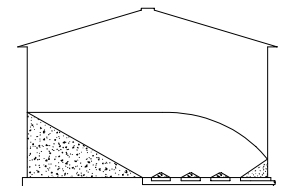

**Fig. 4**  
**Grain Flow Through Intermediate Wells**

# GENERAL INFORMATION

## **DRIVE-POWER CALCULATION**

These conveyors can be made to fit specific requirements. Systems can be situated in a horizontal, inclined, horizontal-to-incline or horizontal-to-vertical. Use the following tables to help determine the proper size motor for your application.

1. Select the desired capacity and closest angle of operation.
2. Using the following tables, determine what the "H.P. per foot" (*kw/m*) is for the selected capacity and angle of operation.
3. Multiply the conveyor length by "H.P. per foot" (*kw/m*) to find required horsepower (*kw*). Use the next larger size standard motor.

**Drive Power Formula:**

Conveyor length x "H.P. per foot" (*kw/m*) = Required H.P. (*kw*).

**Example:**

Model 50

60' (18.29 m) long Conveyor

Angle of Operation - 30°

Capacity - 3300 BPH (89 TPH)

Table Shows - .136 "H.P. per Foot" (.331 *kw/m*)

Length of Conveyor, 60' x .136 = 8.16 H.P. (18.29 m x .331 = 6.05 *kw*)

Use a 10 H.P. (7.5 *kw*) motor

**Model 50 Power Table**

Model 50	Up To 2500 BPH (68 TPH) 150 FPM (45.72 MPM)				Up To 3300 BPH (89 TPH) 200 FPM (60.96 MPM)			
	Horz	15°	30°	45°	Horz	15°	30°	45°
HP Per Foot ( <i>kw/m</i> )	.048 (.117)	.072 (.175)	.103 (.251)	.137 (.334)	.063 (.153)	.095 (.231)	.136 (.331)	.181 (.441)
Maximum Length FT (m)	300' (91)	200' (61)	140' (43)	100' (30)	300' (91)	210' (64)	140' (43)	100' (30)
Max. HP ( <i>kw</i> )	15 (11)	15 (11)	15 (11)	15 (11)	20 (15)	20 (15)	20 (15)	20 (15)

Model 50	Up To 4150 BPH (112 TPH) 250 FPM (76.20 MPM)					Up To 5000 BPH (135 TPH) 300 FPM (91.44 MPM)					
	Horz	15°	30°	45°	60°	Horz	15°	30°	45°	60°	90°
HP Per Foot ( <i>kw/m</i> )	.078 (.190)	.119 (.290)	.169 (.412)	.228 (.556)	.327 (.797)	.095 (.231)	.142 (.346)	.207 (.505)	.275 (.671)	.337 (.822)	.394 (.961)
Maximum Length FT (m)	300' (91)	200' (61)	140' (43)	100' (30)	70' (21)	300' (91)	210' (64)	140' (43)	100' (30)	80' (24)	70' (21)
Max. HP ( <i>kw</i> )	25 (18.5)	25 (18.5)	25 (18.5)	25 (18.5)	25 (18.5)	30 (22)	30 (22)	30 (22)	30 (22)	30 (22)	30 (22)

**DRIVE-POWER CALCULATION (con't.)**

**Model 85 Power Table**

Model 85	Up To 4000 BPH (108 TPH) 150 FPM (45.72 MPM)				Up To 5500 BPH (149 TPH) 200 FPM (60.96 MPM)				Up To 7000 BPH (189 TPH) 250 FPM (76.20 MPM)				
	Horz	15°	30°	45°	Horz	15°	30°	45°	Horz	15°	30°	45°	60°
<b>HP Per Foot (kw/m)</b>	.067 (.163)	.107 (.261)	.158 (.385)	.211 (.514)	.092 (.224)	.147 (.358)	.215 (.524)	.292 (.712)	.118 (.287)	.187 (.456)	.277 (.675)	.372 (.907)	.457 (1.11)
<b>Maximum Length FT (m)</b>	220' (67)	140' (43)	90' (27)	70' (21)	210' (64)	130' (40)	90' (27)	60' (18)	210' (64)	130' (40)	90' (27)	60' (18)	50' (15)
<b>Max. HP (kw)</b>	15 (11)	15 (11)	15 (11)	15 (11)	20 (15)	20 (15)	20 (15)	20 (15)	25 (18.5)	25 (18.5)	25 (18.5)	25 (18.5)	25 (18.5)

Model 85	Up To 8500 BPH (230 TPH) 300 FPM (91.44 MPM)						Up To 10,000 BPH (270 TPH) 400 FPM (121.92 MPM)				
	Horz	15°	30°	45°	60°	90°	Horz	15°	30°	45°	60°
<b>HP Per Foot (kw/m)</b>	.143 (.348)	.227 (.553)	.336 (.819)	.451 (1.10)	.559 (1.36)	.667 (1.623)	.18 (.439)	.28 (.683)	.42 (1.024)	.56 (1.365)	.70 (1.706)
<b>Maximum Length FT (m)</b>	280' (85)	170' (52)	110' (34)	80' (24)	70' (21)	55' (17)	200' (61)	130' (40)	90' (27)	65' (20)	50' (15)
<b>Max. HP (kw)</b>	40 (30)	40 (30)	40 (30)	40 (30)	40 (30)	40 (30)	40 (30)	40 (30)	40 (30)	40 (30)	40 (30)

**Power Requirement for a Conveyor that Includes a Corner Section**

1. Calculate the power for the Inclined Section using the same formula shown on Page 8.
2. Calculate the power for the Horizontal Section.
3. For the Corner Section, calculate the power that would be needed for an additional 20 ft. (6.10 m) of Horizontal Conveyor.
4. Total the power for the Inclined, Horizontal and Corner Sections.  
This is the total H.P. (kw) required.

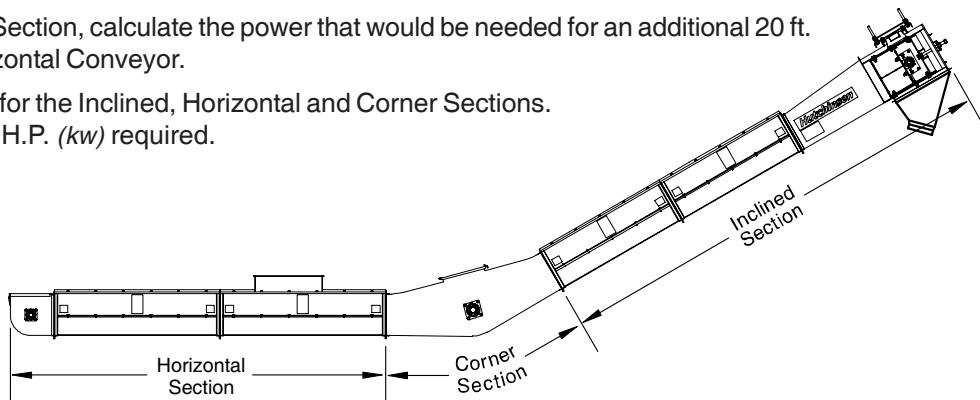

# OPERATING PROCEDURES

## OPERATING PROCEDURES



**WARNING! Make certain everyone is clear before operating the equipment.**

The operator shall be aware of any unusual vibrations or noises that would indicate the need for service or repair.

Keep all safety shields in place.

Keep hands, feet and clothing away from moving parts.



The operator shall have a full view of the entire work area and check that all personnel are clear of the designated work area before adding power.

If the operator must leave the work area, or whenever servicing or adjusting, the conveyor must be stopped and the power source turned off and locked out.



Precaution should be made to prevent anyone from operating the conveyor when the operator is absent from the work area.

The reset and starting controls must be located so that the operator has full view of the entire operation.

Do Not enter the grain bin unless all power driven equipment has been shut down and locked out.

Make certain electric motor is grounded.



Disconnect power before resetting motor overloads.

Shut off power and lockout whenever cleaning or servicing the conveyor.

Never enter the bin when the sweep auger is in operation. Never attempt to control the operation of the sweep auger by pushing on an operating sweep auger with shovels, brooms or other devices.



Do Not attempt to restrain the movement of the sweep auger by attaching ropes, bars or other devices to be held by an operator.

1. Start the conveyor for operation. Open the conveyor outlet gate for the desired discharge point (all gates should be closed except the one at the selected discharge point).

2. If moving grain from bins or storage structures, gradually open the gate in the center well until desired flow is established. **Do Not** overload the conveyor.

If intermediate wells are used, they should be opened **after** grain has stopped flowing into the center well.

When the desired amount of grain has been moved or unloaded, close all bin wells and allow the conveyor to clean itself out. **Shut down and lock out power source.**

3. If moving grain through a dump hopper, begin unloading grain from dump vehicle in small increments and gradually build up to desired flow. **Do Not** overload conveyor.

After grain flow from dump vehicle has stopped, allow the conveyor to clean itself out and close outlet gate. **Shut down and lock out power source.**

### EMERGENCY SHUTDOWN

Should the machine need to be immediately shut down under full load, **disconnect** and **lockout** the power source. Clear as much grain from the hopper and conveyor as possible. Use the release door provided in the standard corner to drain the vertical tube after the dump hopper.

**Never attempt to restart when full. Starting the unit under full load may result in damage.** Such damage is considered abuse of the equipment and will not be warranted.

### NORMAL SHUTDOWN

Close flow controls in bin wells and allow the conveyor to empty before stopping the unit.

**Before the operator leaves the work area, the power source shall be locked out.**

### INTERMITTENT SHUTDOWN

When a conveyor is stopped and started under full load, it may result in damage to the conveyor. Therefore, if intermittent operation is to be carried out, it is advisable to reduce the load level.

If a conveyor is kept from absolute filling, it will make start-up easier and will convey grain more efficiently.

### LOCKOUT

The power source shall have a main disconnect box that can be locked only in the “**Off**” position. This is what “shutdown and lockout” refers to, shut off the main power source and lock handle or breaker switch in the “**Off**” position.

## GENERAL MAINTENANCE INFORMATION



**WARNING!** A main power disconnect switch that can be locked in only the “OFF” position shall be provided. This shall be locked whenever work is being done on the conveyor.



Keep all safety shields and devices in place.

Never clean, adjust or lubricate a machine that is in operation.

Disconnect power before resetting motor overloads.



Shut off power and lockout whenever cleaning or servicing the conveyor.

Keep hands, feet and clothing away from moving parts.

For economical and efficient operation of the Mass-Ter Mover, maintain regular and correct lubrication. Neglect leads to reduced efficiency, excessive wear, and needless down time. Regular inspections should be established in order to ensure that the equipment is in good operating condition at all times. Use the “Machine Inspection” list on Page 6 for guidelines.

The following information will detail the parts that require lubrication and the various conditions that determine the frequency span.

## CONVEYOR CHAIN

It is important not to overtighten the conveyor chain. However, if the chain is not sufficiently tight, it will slip at the lower drive sprocket as capacity is increased. Should this occur, shut off grain flow to the unit and allow conveyor to clean itself out. **Shutdown and lockout the power source (See Page 10).**

To check conveyor chain tension, grasp one of the paddles at the intake end and attempt to rotate it up toward the chain. Proper chain tension should allow only minimum rotation of the paddle (See Fig. 1).

### IMPORTANT SERVICE - MAINTENANCE NOTICE:

**The life of the conveyor chain will be shortened when the chain is allowed to sit in water or is operated in acidic conditions, so avoid these situations as much as possible.**

**To extend chain life, spray a light coat of vegetable oil on the chain after each season’s use.**

Regular inspections should be established in order to ensure that the conveyor chain is in good operating condition at all times.

## CONVEYOR CHAIN (con’t.)

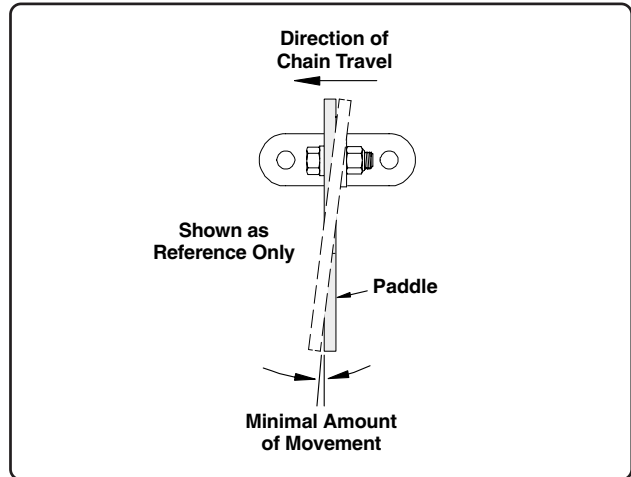

Fig. 1

Inspect the conveyor chain for loose bolts, missing chain parts, missing or damaged chain paddles and overall chain condition.

Check conveyor sprocket to see that it is centered and setscrews are tight.

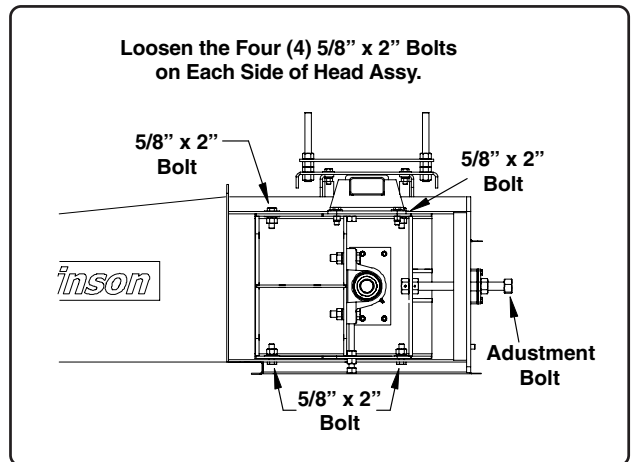

Fig. 2

Loosen the four 5/8 inch x 2 inch bolts on each take-up slide at the discharge end of the unit. Turn the adjustment bolts in desired direction to either loosen or tighten the chain (move adjustment bolts in equal increments so that the sprocket shaft remains straight).

Limit the tightening process to 1/4 inch (6 mm) of travel for conveyors 70 ft. (21 m) and longer and to smaller increments for shorter conveyors. Repeat tightening process as necessary. If chain is still too loose after these adjustments, it may be necessary to remove one or more links from the chain.

**GEAR REDUCER**

**IMPORTANT!** Because the gear reducer is shipped **without oil**, it is necessary to add the proper amount of oil before conveyor operation. Use a high grade petroleum base, rust and oxidation inhibiting (R & D) gear oil. **Follow the recommendations in the instruction manual provided with the reducer, and on the reducer's name plate and warning tags.**

To add oil, remove the level check plug from the side of the reducer (See Fig. 3). Remove the vent/fill plug from the top of the reducer. Add oil until oil begins to flow from the level check hole. Replace both plugs.

Under normal industrial operating conditions, the lubricant should be changed every **2500 hours of operation or every six (6) months**, whichever occurs first. Drain the reducer and flush it with kerosene, clean the magnetic drain plug and refill reducer to its proper level with new lubricant.

**CAUTION: Too much oil will cause overheating and too little oil will result in gear failure. Check oil level regularly**

Under extreme operating conditions, such as rapid rise and fall of temperature, dust, dirt, chemical particles, chemical fumes, or oil pump temperatures above 200°F (93.3°C), the oil should be changed every **1 to 3 months** depending on severity of conditions.

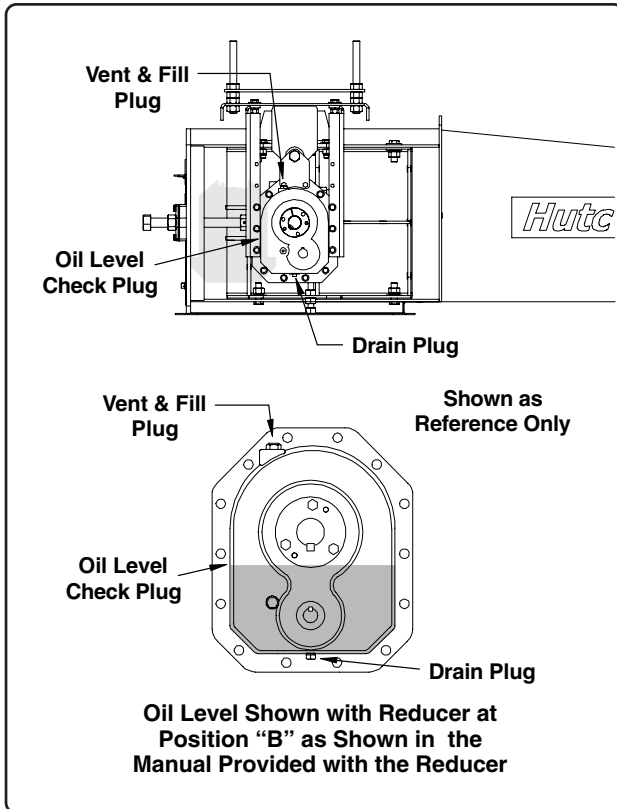

Fig. 3

For reducers operating in ambient temperatures that range between -22°F (-30°C) and 20°F (-6.6°C), the use of a synthetic hydrocarbon lubricant, 100 grade or AGMA 3 grade (for example, Mobil SHC627) is recommended.

**Capacities:**

Note: Capacities are approximate. Units should always be filled until oil runs out of the level check hole.

**Reducer TA0107L15**

f/ 3 & 5 HP (2.2 & 4 kw) systems

approx. **0.5 qts. (0.5 L)**

**Reducer TA1107H15**

f/ 5, 7.5 & 10 HP (4, 5.5 & 7.5 kw) systems

approx. **0.7 qts. (0.7 L)**

**Reducer TA2115H15**

f/ 7.5, 10 & 15 HP (5.5, 7.5 & 11 kw) systems

approx. **1.2 qts. (1.2 L)**

**Reducer TA3203H15**

f/ 10, 15 & 20 HP (7.5, 11 & 15 kw) systems

approx. **1.6 qts. (1.6 L)**

**Reducer TA4207H15**

f/ 15, 20, 25, 30 & 40 HP systems

(11, 15, 18.5, 22 & 30 kw)

approx. **2.6 qts. (2.5 L)**

**Reducer TA5215H15**

f/ 40 HP (30 kw) systems

approx. **4.9 qts. (4.7 L)**

**BEARING LUBRICATION**

The bearings used in the various components of the conveyor system are equipped with lubrication fittings (grease zerks).

These bearings are self-aligning, sealed ball bearings which have been packed at the factory. They should be lubricated at approximately **fifty (50) hour intervals** with an SAE multipurpose type grease (See Fig. 4, Fig. 5 & Fig. 6). **Typically only 1 pump is sufficient, Do Not over grease as this may damage the seals on the bearings.**

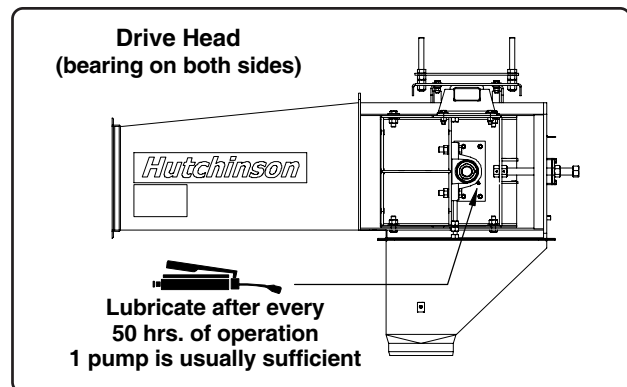

Fig. 4

## BEARING LUBRICATION (con't.)

Inspect bearings closely for wear and/or seal damage. Check that the bearings and lock collars are firmly fastened.

These bearings use an eccentric type lock collar. To tighten this type of lock collar, first slide it against the cam end of the inner ring of the bearing. Rotate collar in the direction of shaft rotation until the cams engage. Tap the collar further into this rotation to lock it, then tighten the setscrew.

Check all setscrews and hardware for tightness.

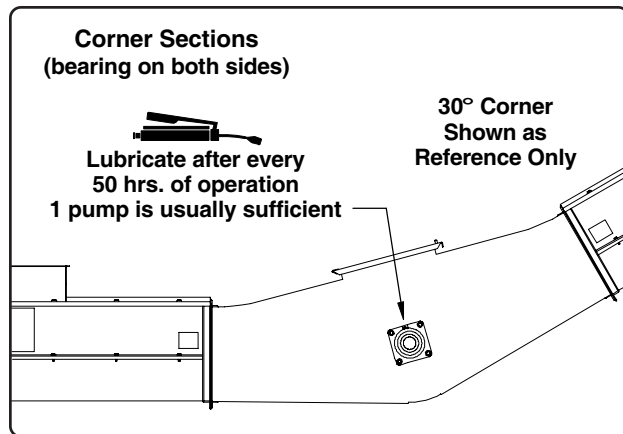

Fig. 5

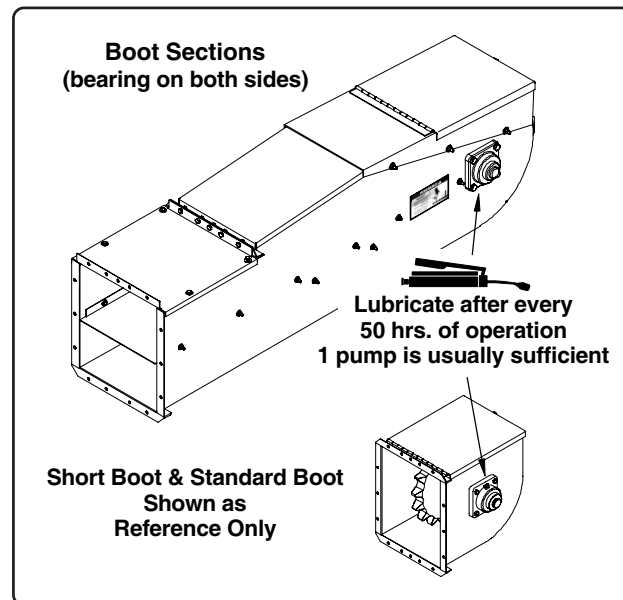

Fig. 6

## DRIVE BELTS

Inspect belts closely for cracks, fraying, stretching or other signs of damage. Replace or tighten belts as necessary.

**Refer to the assembly section for proper tightening procedures.**

## TROUBLE SHOOTING



**WARNING! Never clean, adjust or lubricate a machine that is in operation.**

**Shut off power and lockout whenever cleaning or servicing the conveyor.**

### 1. Extreme noise from housing.

- A. Conveyor chain is too loose. Chain is slipping at drive sprocket. Check chain tension and adjust as necessary.
- B. Improper assembly or misalignment of trunking. Loosen trunk connection(s) that are the source of noise and disassemble. Check for end smoothness and grind, if necessary.
- C. A conveyor sprocket is not centered in a corner unit causing paddles to rub hard on conveyor sides. Sprocket must be moved on shaft to center position and locked.

### 2. Belt slippage on electric drive.

- A. Incorrect belt tension. Turn the adjustment bolts on the motor mount until proper tension is reached.
- B. Unit is plugged. Clear the grain and any obstructions from the machine as is possible.

### 3. Grain returning to the intake.

- A. The discharge spout may be installed backwards. Spout must be mounted so that it slopes back towards the main body of the unit.
- B. Partially blocked discharge; remove obstruction.

### 4. Unit not running to full capacity.

- A. Grain is high in moisture causing lower capacity. Excessive feeding of high moisture grain can cause plugging.
- B. Chain speed is too slow.
- C. Obstruction at intake.

### 5. Paddle breaking or bending.

- A. Paddles may be coming loose from the chain. Keep paddles securely connected to chain.
- B. Trunking misalignment.
- C. Frequent starts under loads. Allow machine to clean out before shutting down.
- D. Sprockets may be off center. Align in center of housing.
- E. Overfeeding; adjust the feeding of the unit to allow less grain to enter while maintaining full speed.

## LAYOUT & DESIGN IDEAS

The Mass-ter Movers will handle a wide range of free flowing grains. It should not be used with highly corrosive material such as fertilizer.

A completed conveyor has a fixed grain flow. Grain is carried in the bottom section to the discharge end, with chain travel toward the inlet (boot) end in the top section. The trunk sections must be assembled with the center partitions overlapped at these connecting points for correct flow direction (refer to the trunk assembly section for proper installation). **The conveyor should never be operated in the reverse direction.**

Conveyor sections are available in solid, welded top construction or a bolt-on cover. The bolt-on cover is convenient for service and/or inspection. **Units must not run without the covers in place.**

Customer preference will govern the style of cover choice. However, when a 15°, 30°, 45° or 90° corner is used, the first section after it (towards discharge end) must be the solid top style. **A bolt-on cover section should never be used as the first section after a corner towards the discharge end.**

A 15°, 30°, 45° or 90° incline section can be used with any unit, however, the horizontal portion should not exceed 40' (12.19 m). See horsepower charts for design limits on the incline section.

If the Mass-Ter Mover is installed out-of-doors, we recommend trunk flange joints & bolt-on covers be sealed with a liquid-tight sealant (such as caulking) to prevent moisture from entering the system.

## CONVEYOR CAPACITY INFORMATION

- The capacity charts for the Mass-Ter Mover reflect actual achievable results (see Pages 8 & 9). However, good design generally will suggest using the next higher speed-capacity rate. This assures capacity without requiring absolute full 100% output.
- The charts also show the recommended maximum lengths for various applications. **Do Not exceed the maximum lengths listed.** Mass-Ter Movers must be adequately supported to be rigid and straight. Supports should be sufficient on 20' (6.10 m) centers (a maximum span for supports is 30' (9.14 m)).
- Overfeeding a Mass-Ter Mover may cause plugging. Intake rate should not exceed the particular capacity of the drive and chain travel speed.

## INLET INFORMATION

- The standard boot contains an inlet cover located approximately 5' (1.52 m) from the end. If this is used as an inlet, you will need to add the inlet adapter. The hinged inspection cover at the extreme end may also be used as an inlet (refer to the Inlet Assembly section for proper installation procedures).
- Center and intermediate bin well inlets allow grain to flow directly into the lower grain conveying section, as a result, it is not necessary to use an inlet adapter or drop through section with them.
- For intermediate inlets, you must use the optional units provided in this manual and in the product catalog. They contain necessary chain and paddle guides and inlet flow control. **Do Not** cut random inlets without using these inlet adapters and/or inlet hoppers (refer to the Inlet Assembly section for further information).
- When intermediate inlets are a significant distance from the inlet (boot end), you may wish to use a drop-through section. This will allow grain to drop through to the lower section without having to travel to the boot end (see "Inlet Assembly" section for further reference).
- The inlet must be located in the first section toward the discharge end from the drop-through section (an inlet will not perform satisfactorily if it is located in the same section as the drop-through).
- **The distance that grain is conveyed "Backward" (through upper trunk section) to a drop-through or to the boot end, should be added to total length to properly determine horsepower requirements.** Use different lengths of conveyor sections to adjust outlet to desired location.

## TRUSS INFORMATION

For supports of spans of up to 50' (15 m) on permanently installed Mass-Ter Mover systems, a truss support system is recommended. **Note: Support rails for the truss system must be welded to the Mass-Ter Mover** (see Truss Assembly section for proper installation procedures).

## TRUNKING ASSEMBLY



**WARNING!** Some system components and parts are heavy, use assistance with lifting and while assembling these parts.



Keep hands, legs and other body parts out from under conveyor sections when sections are being raised by the hoist or by any other means.



Wear the proper personal protective gear (ie. safety glasses, ear protection, gloves, etc.).

Keep the assembly and work area clean and free of tools and objects which could cause unsafe situations.

Assembly of a stationary Mass-Ter Mover Conveyor System is unique with each and every situation. There are some systems that may be comprised of a number of trunk sections (solid or bolt-on covers). Some may have a variety of inlets and outlets, including hoppers, pit hoppers, spouts and inclined sections.

Other systems may be extremely simple comprised of only a hopper, trunk section and discharge.

The following assembly instructions offer information as how to assemble all possible components in any given system, simple or complex.

### Assemble Trunking Sections

The Mass-Ter Mover should be assembled on a level surface that is spacious enough to accommodate the unit when laid out full length. It is recommended that the unit be elevated 3' to 4' (91.4 cm to 1.22 m) above ground level during assembly.

Make sure the support stands or blocks are well anchored to prevent tipping. Assembly area should have access to a chain hoist or other lifting device.

During assembly, all bolts should be tightened to the recommended torque. Refer to the torque chart located at the end of the parts section (Page P-70) for proper torque values in relation to bolt size.

1. Position the trunk and/or corner sections in their respective order as determined by your application.
2. Note the center partition in each of the trunk housings. During assembly, the center partition in the next trunk to be installed will overlap on top of the center partition of the previous section (See Fig. 7). The reason for the over lap is so that the paddles in the upper section (when traveling back to the boot end) will have a smooth transition from trunk section to trunk section.

3. Secure all trunking sections using 3/8" x 1" bolts, lock washers and non-lock nuts (this also includes the connection of the trunk section to the drive head, boot section and corner section).

Fig. 7 shows a trunk section being attached to a corner section. Any trunk section can be attached to a corner section but, **a boot section cannot be attached to a corner section.**

When installing a corner section, ensure that the inspection door is accessible and oriented as shown in Fig. 7, and that the hinge on the access door is facing down.

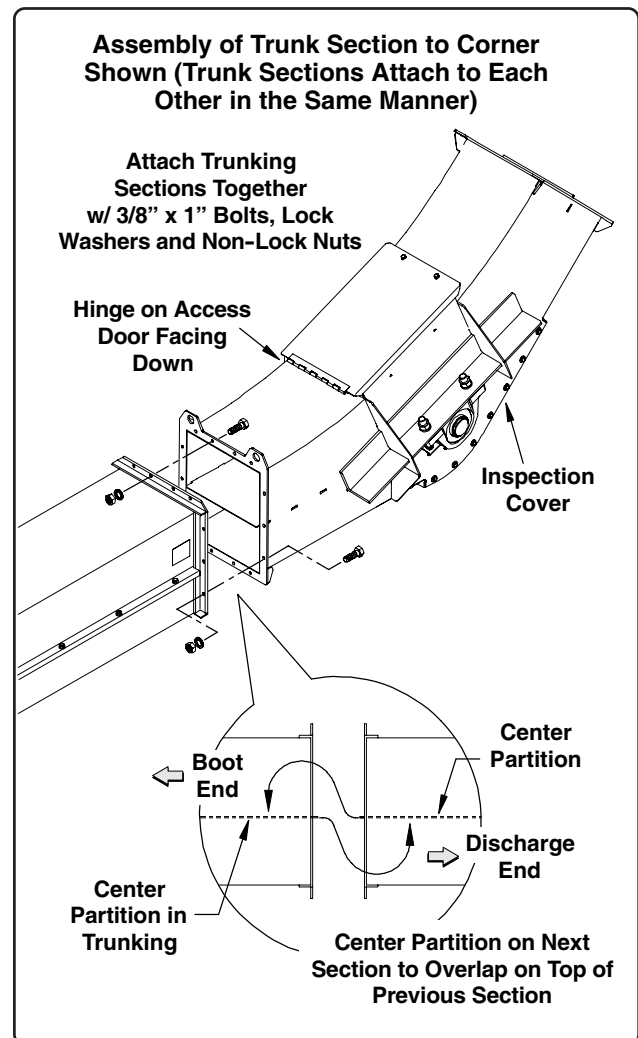

Fig. 7

**Note:** If Mass-Ter Mover is installed out-of-doors, we recommend the trunk flange joints be sealed with a liquid-tight sealant (such as calking) to prevent moisture from entering the system.

# ASSEMBLY INSTRUCTIONS

## TRUNKING ASSEMBLY (con't.)

- For units with bolt-on covers, attach the covers to the trunk sections using 5/16" x 3/4" bolts, lock washers and non-lock nuts. A short splice plate will be installed at each of the trunk section joints as shown in Fig. 8 below.

The trunks are connected using 3/8" x 1" bolts, lock washers and non-lock nuts.

When connecting trunk sections, use the same overlap procedure for the center partition as detailed on Page 15.

### Bolt-On Cover to Bolt-On Cover Trunk Connection

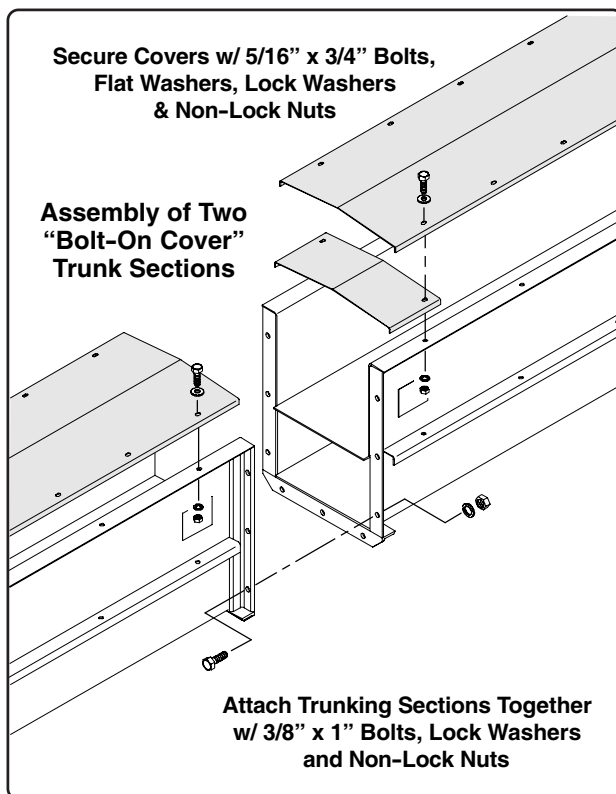

Fig. 8

Note: If the Mass-Ter Mover is installed out-of-doors, we recommend the trunk flange joints and bolt-on covers be sealed with a liquid-tight sealant (such as calking) to prevent moisture from entering the conveyor system.

- A bolt-on cover trunk section can also be connected to a solid cover trunk as shown in Fig. 9 below. The trunks are connected using 3/8" x 1" bolts, lock washers and non-lock nuts.

Use the same overlap procedure for the center partition as detailed on Page 15.

- A cover support bracket will need to be installed when making the bolt-on cover to solid cover connection (See Fig. 9). Secure the support bracket to the solid cover trunk section using 3/8" x 1" bolts, lock washers and non-lock nuts.

### Bolt-On Cover to Solid Cover Trunk Connection

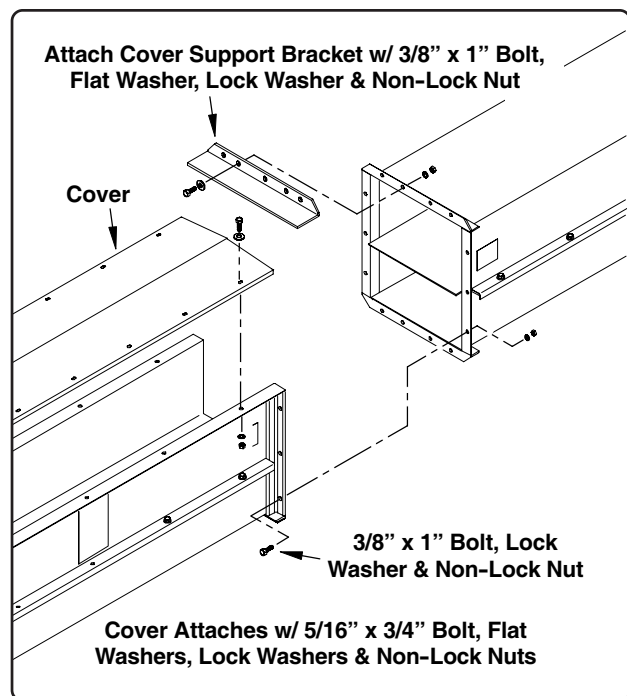

Fig. 9

Note: If the Mass-Ter Mover is installed out-of-doors, we recommend the trunk flange joints and bolt-on covers be sealed with a liquid-tight sealant (such as calking) to prevent moisture from entering the conveyor system.

## CONVEYOR CHAIN & PADDLES



**CAUTION!** The areas around the chain sprockets can create pinch points causing personal injury. Use caution when working around these areas. Keep hands, feet and all body parts away from moving components.

It is important to install the chain so the paddle mounting brackets will be behind the paddles as grain is moved up the trunk (See illustration below).

### IMPORTANT SERVICE-MAINTENANCE NOTICE

The life of the conveyor chain will be shortened when the chain is allowed to sit in water, become saturated for long periods of time, or is operated in acidic conditions, so avoid these situations.

To extend chain life, spray a light coat of a vegetable oil on the chain after each season's use.

Regular inspections should be established in order to ensure that the conveyor chain is in good operating condition at all times.

1. Inspect the conveyor chain for loose bolts, missing chain parts, missing or damaged paddles and the overall condition of the chain.
2. Check chain tension as detailed on Page 11 in the "Lubrication and Maintenance" Section.
3. Check conveyor sprockets to ensure they are properly centered and that setscrews are tight.

Continue with chain and paddle installation on the following page (Page 18).

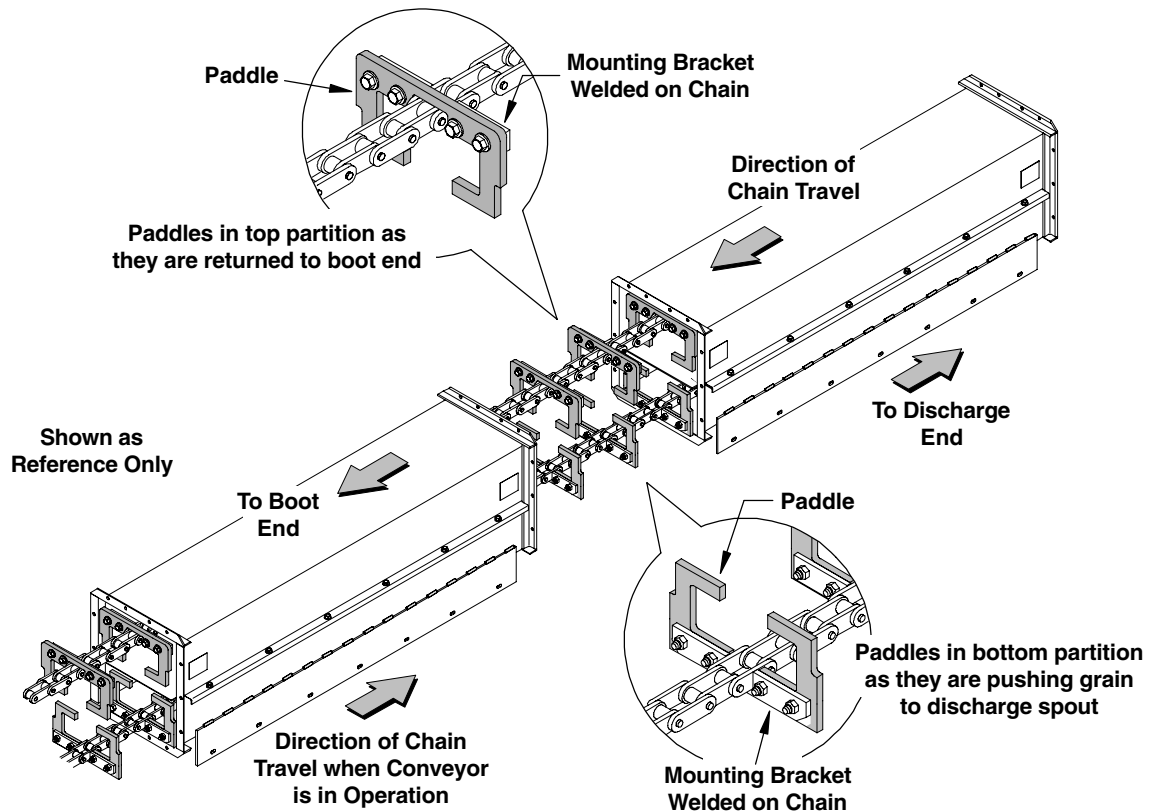

# ASSEMBLY INSTRUCTIONS

## CONVEYOR CHAIN & PADDLES (con't.)

**Note:** Most units will be shipped with the paddles already attached to the chain. If your unit already has the paddles attached, continue with Step 2 below.

If the paddles have not been installed, begin with Step 1 below.

1. Install the paddles so the chain mounting brackets are behind the paddles (See Fig's. 10 & 11).

For Model 50 units attach the paddles to the chain brackets using 5/16" x 1 1/4" bolts, flat washers and nylon locknuts.

For Model 85 units attach the paddles to the chain brackets using 5/16" x 1 1/2" bolts, flat washers and nylon locknuts.

**IMPORTANT!** Do Not overtighten bolts when attaching the paddles to the chain. Excessive tightening can deform the paddles.

Recommended torque on the paddle bolts is 15 to 20 ft. lbs. (20.3 to 27.1 n-m).

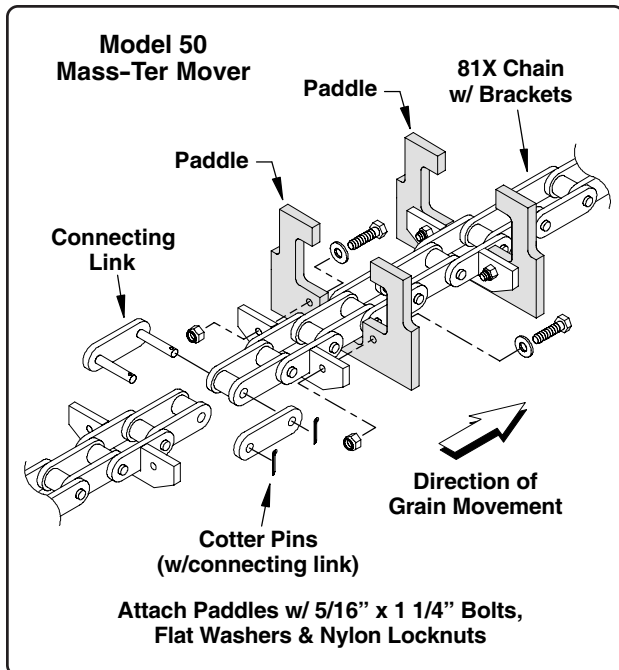

Fig. 10

2. The chain model number is stamped on the sides of the chain links. Be sure **ALL** of the conveyor chain is of the same type.

Start the chain at any of the openings such as the boot end, head end or corner section. Either of these options can also be used for the final chain link connection.

Use an electrical fish tape, wire or rope to pull the chain and paddles through the conveyor.

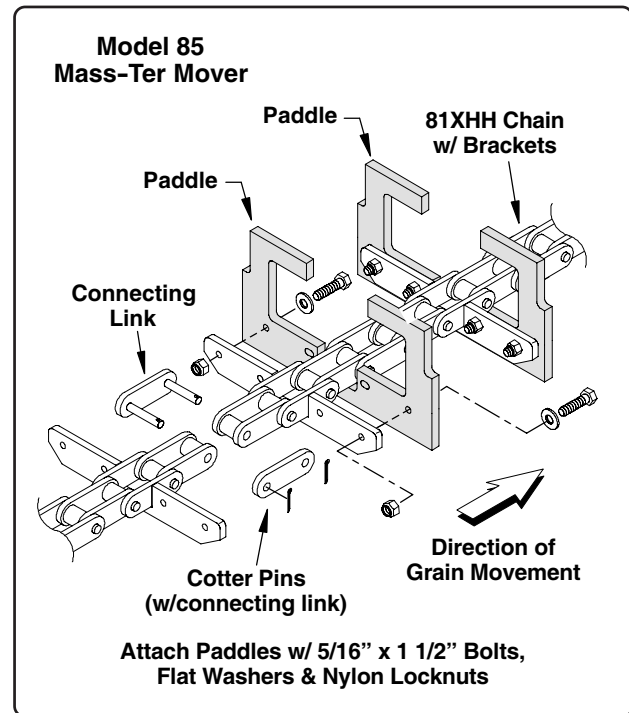

Fig. 11

3. After the chain and paddles have been installed through the conveyor housing and around all the sprockets, connect the ends of the chains together using the connecting link and cotter pins provided (it may be necessary to loosen the take-up slides on the head section in order to connect the ends of the chains together).
4. Once the chain has been properly installed, check chain tension by grasping one of the paddles and attempt to rotate it up towards the chain. Proper tension should allow only minimal movement of the paddle. **Refer to Page 11 for chain tension and proper adjustment procedures.**

## HEAD DRIVE ASSEMBLY



**WARNING!** A main power disconnect switch that can be locked in only the “OFF” position shall be provided. This shall be locked whenever work is being done on the conveyor.

**Shut off power and lockout whenever cleaning or servicing the conveyor.**

The drive components and motor mounts are assembled onto the head section at the factory. The electric motor (not furnished), belt guard, sheaves and drive belt(s) will only need to be installed.

Always use a motor with required HP (*kw*) as calculated using tables shown on Pages 8 & 9. Use a 60 hz motor that operates at 1750 rpm (*50 hz @ 1460 rpm*).

**Electrical motor and controls shall be installed by a qualified electrician and must meet the standards set by the National Electrical Code and all local and state codes.**

**Refer to Page 7 for further motor drive information.**

**Note: The reducer gearbox is shipped without oil. If oil has not been added as of yet, it would be easier to do so now before the belt guard is installed. Refer to Page 12 for proper levels and filling procedures.**

1. Install the electric motor onto the motor mount plate, using the hardware furnished with the motor. Do Not tighten at this time. The motor will be repositioned when aligning the sheaves.

2. Install the belt guard mount brackets as shown in the illustration below. Secure the brackets to the motor mount support angles with 5/16” x 1 1/4” bolts, flat washers and nylon locknuts. **Do Not tighten completely at this time.**
3. Attach the belt guard to the brackets using four (4) 5/16” x 1 1/4” bolts, flat washers and nylon locknuts (use the mounting slots in the belt guard that best line up with the mounting holes in the motor mount support angles).
4. Use the sheaves provided with the unit (if another size sheave is used or substituted, improper chain speed and unsatisfactory operation will occur). Install the sheaves and bushing according to the information provided in the parts section [the parts description will say if its the drive (motor) or driven (reducer) sheave]. Make sure the drive keys are properly installed. Mount the sheaves as close to the back of the belt guard as possible.
5. Align the sheaves using a straight edge placed along the face of the sheaves. Tighten into place.
6. Install the belt(s) and adjust belt tension. Set belt tension using the four adjustment bolts, moving them in equal increments to keep motor plate level. Proper tension should be approx. 9/16” (*15 mm*) of deflection when the belts are firmly pressed in the center of the span between the two sheaves.
7. Tighten all belt guard mounting hardware.

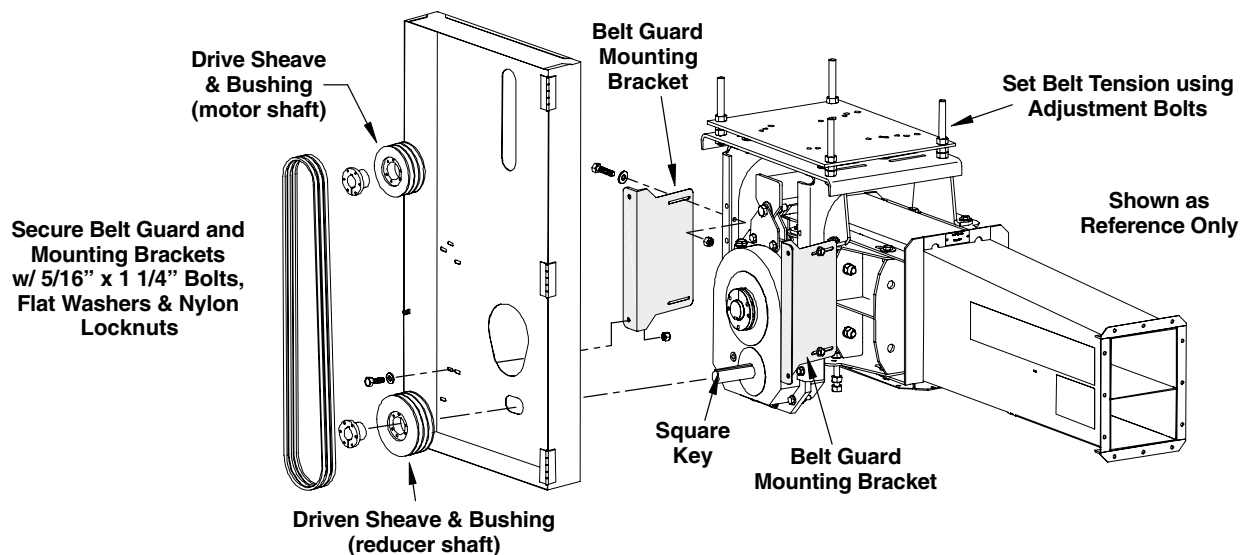

## 40' STATIONARY TRUSS ASSEMBLY

### Model 50 and Model 85

**Note:** Whether your trunk sections are the bolt-on or solid cover type, the truss mounting plates will need to be welded onto the sides of the trunking sections as detailed below.

1. Position the truss plates along the sides of the trunk sections with the holes down and 3 1/2" (89 mm) below the bottom of the trunk. Center the plates between the flanges on the end of each trunk section [when centered there should be approx. 1 5/8" (41 mm) spacing at between the end of the plate and flange, See illustration below].
2. Weld the mounting plates to the sides of the trunk sections with 1/8" (3 mm) fillet welds [1 1/2" (38 mm) long] centered on every eight inches (20.3 cm). After the top of the mount plates have been welded, weld the plates to the bottom sides of the trunk section with the welds staggered between the welds on the sides.

Once all mount plates have been welded into position, apply a coat of a good quality exterior, rust proof paint to all weld seams.

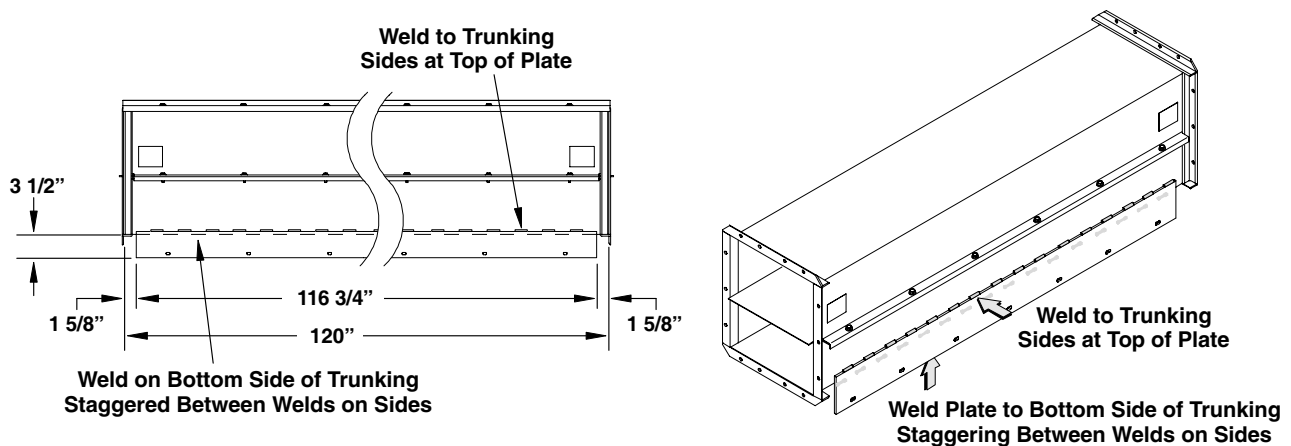

3. The truss sections include two (2) 20' (6.10 m) main truss sections (reference No. 1 in illustration on following page, these sections are identical) and four (4) wing trusses (reference No. 2 on following page, there are two left and two right side wing trusses).

Connect the wing truss sections to the main truss using 3/8" x 1" bolts, lock washers and non-lock nuts (See illustration on following page). Tighten these bolts now (leave all other bolts loose during the remainder of the assembly process, these will be tightened after completion of the truss assembly).

4. Position the truss sections along the trunk sides so they are equally centered across the horizontal span of the trunk sections. Note: There are eleven (11) spacer bars (reference No. 3 on following page) that will be used along the top side of the truss sections. Determine the location you want to install these, spacing them across the length of the truss (typically one at each end and the others staggered in between, See illustration on following page).

Align holes in the truss sections with the holes in the mounting plates. Attach the truss sides to the mount plates placing the spacer bars in between the tops of the truss at their predetermined location.

Secure the truss sections to the mount plates using 3/8" x 1" bolts, flat washers (two per bolt), lock washers and non-lock nuts. Secure the spacer bars using 3/8" x 1 1/4" bolts, flat washers, lock washers and non-lock nuts.

**Do Not** tighten hardware completely at this time.

## 40' STATIONARY TRUSS ASSEMBLY (con't.)

5. Install the two lower connecting plates (reference No. 4 below) to the bottom side of the truss sections (half of the plate will be attached to the flat portion of each main truss section and the other half will attach to the lower portion of each wing truss (See illustration below). Secure the plates using 1/2" x 1 1/4" bolts, lock washers and non-lock nuts, **Do Not** tighten completely at this time.
6. Install the two truss connecting plates (reference No. 5 below) to the two uprights in the middle of the main truss sections as shown in the illustration below. Secure using 3/8" x 3/4" bolts, lock washers and non-lock nuts. Tighten all hardware used to install the truss sections.

### 40' Truss Section Assembly

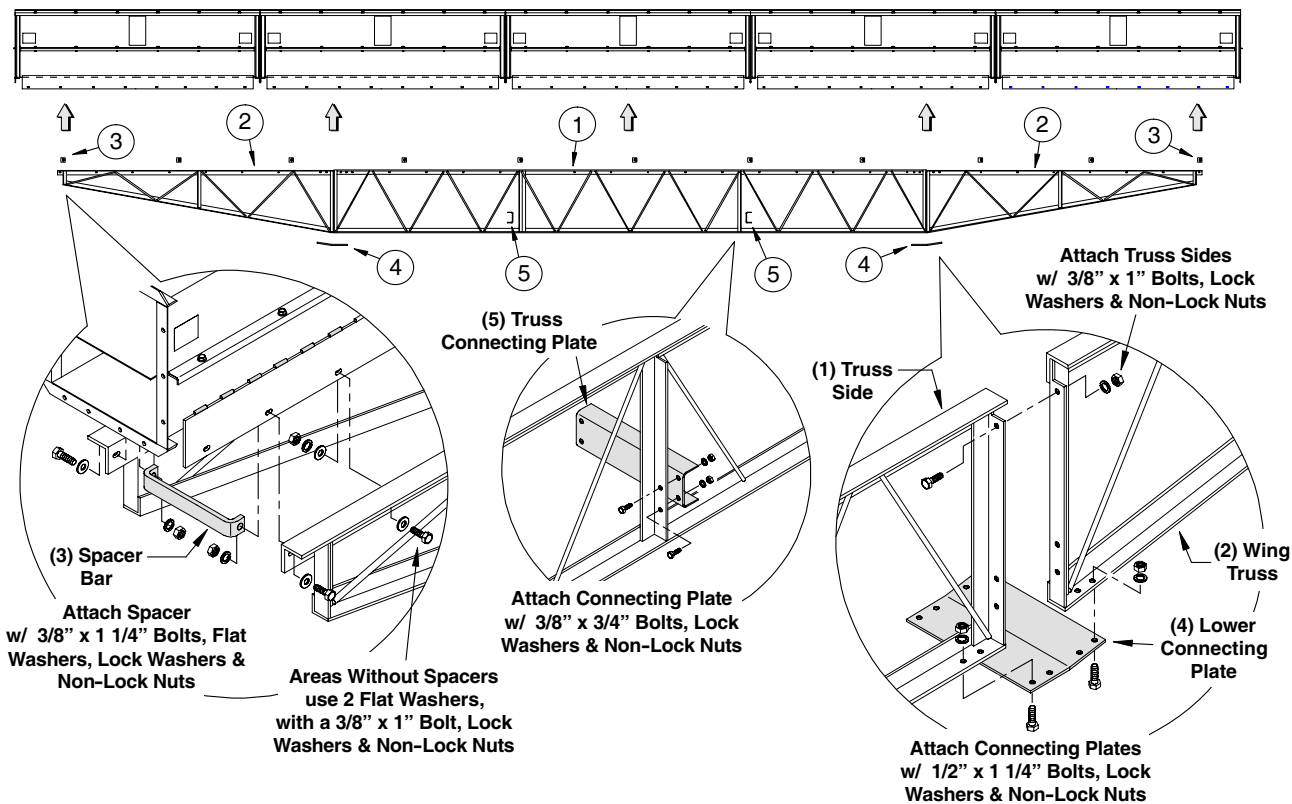

# ASSEMBLY INSTRUCTIONS

## INLET ASSEMBLIES

There are various inlet options that can be installed on the Mass-Ter Mover Conveyor System. These inlets can be installed anywhere along a “Bolt-On Cover” trunk section. Top covers will need to be cut to length after hopper location has been determined.

**IMPORTANT!** The beveled end of the paddle guides on bottom of the inlet must be properly installed to avoid paddle damage. The following illustrations show the correct orientation of the paddle guides.

When an inlet hopper is installed, grain is directed into the upper chamber of the trunk section and travels to the boot end before it enters the bottom chamber. To become more efficient and timely, a drop-through section should be considered, especially if the inlet is a significant distance from the boot end (See illustration on following page).

### Inlet Hopper Installation (24” Wide Inlet)

1. Determine the location for the installation of the inlet. You will need to cut the top cover to length after hopper is located. Install the hopper using 5/16” x 3/4” bolts, flat washers, lock washers and non-lock nuts.

Sealant should be used where covers are attached to the inlet as well as any metal-to-metal contact in which moisture could enter the system. Sealant is also recommended around openings cut in hopper covers for entry of grain from other conveyors or down souets.

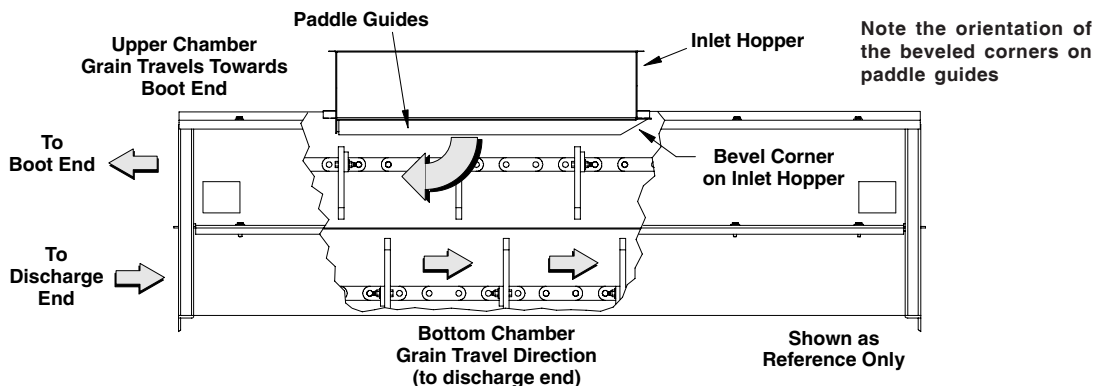
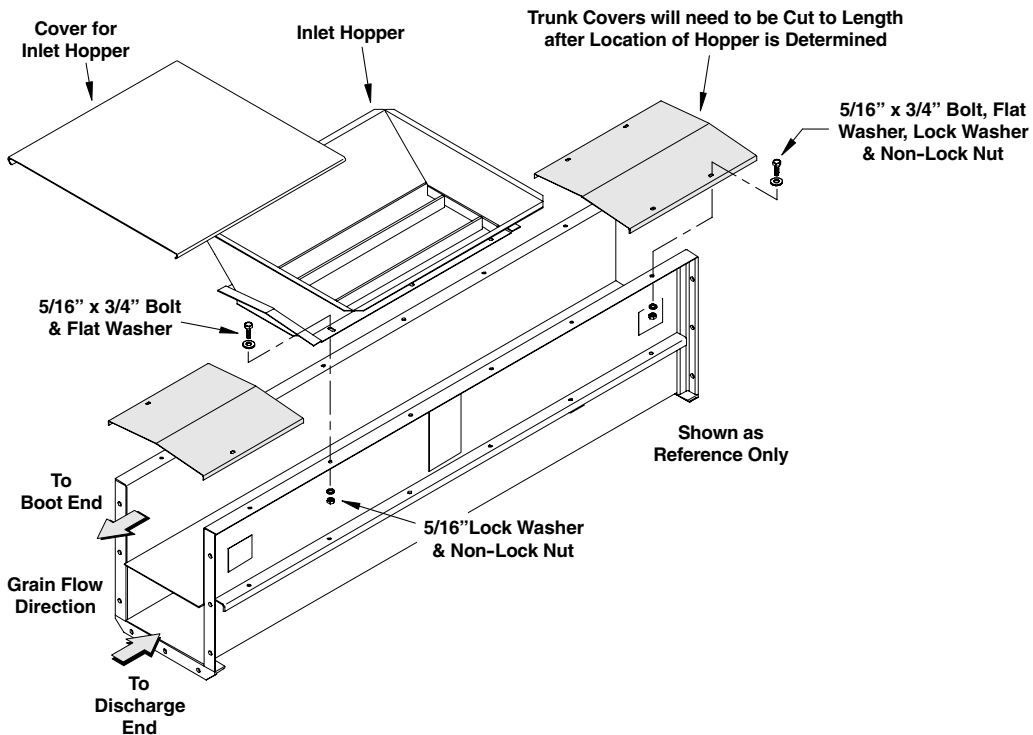

## INLET ASSEMBLIES (con't.)

### Drop-Through Trunk Section

When drop-through sections are used, they should be installed next to the intermediate inlets on the side toward the boot end. This allows grain from the inlet to drop through to the lower chamber at that point, rather than the grain moving to the boot and dropping through there.

The following illustration shows the drop-through section and how the direction of grain travel is affected.

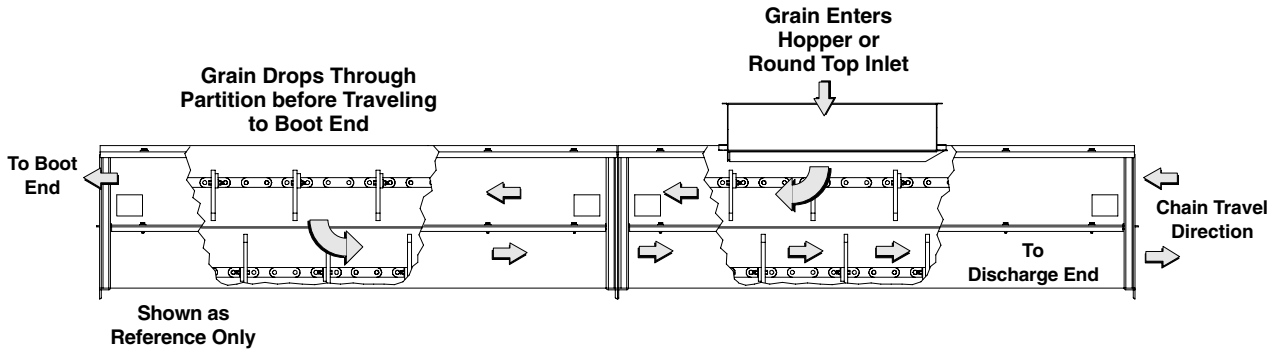

### Inlet Hopper Installation (Round Inlet)

This top inlet hopper can be installed anywhere along a "Bolt-On Cover" trunk section. If bolted next to a trunk flange, a cover support is not needed. The top covers will need to be cut to length after inlet has been located.

1. Install the cover support bracket(s) to the inlet hopper as shown below. Secure support brackets using 3/8" x 1" bolts, flat washers, lock washers and non-lock nuts.

Install the hopper and bolt-on covers using 5/16" x 3/4" bolts, flat washers, lock washers and non-lock nuts.

Sealant should be used where covers are attached to the inlet hopper as well as around the bolt-on covers and support brackets.

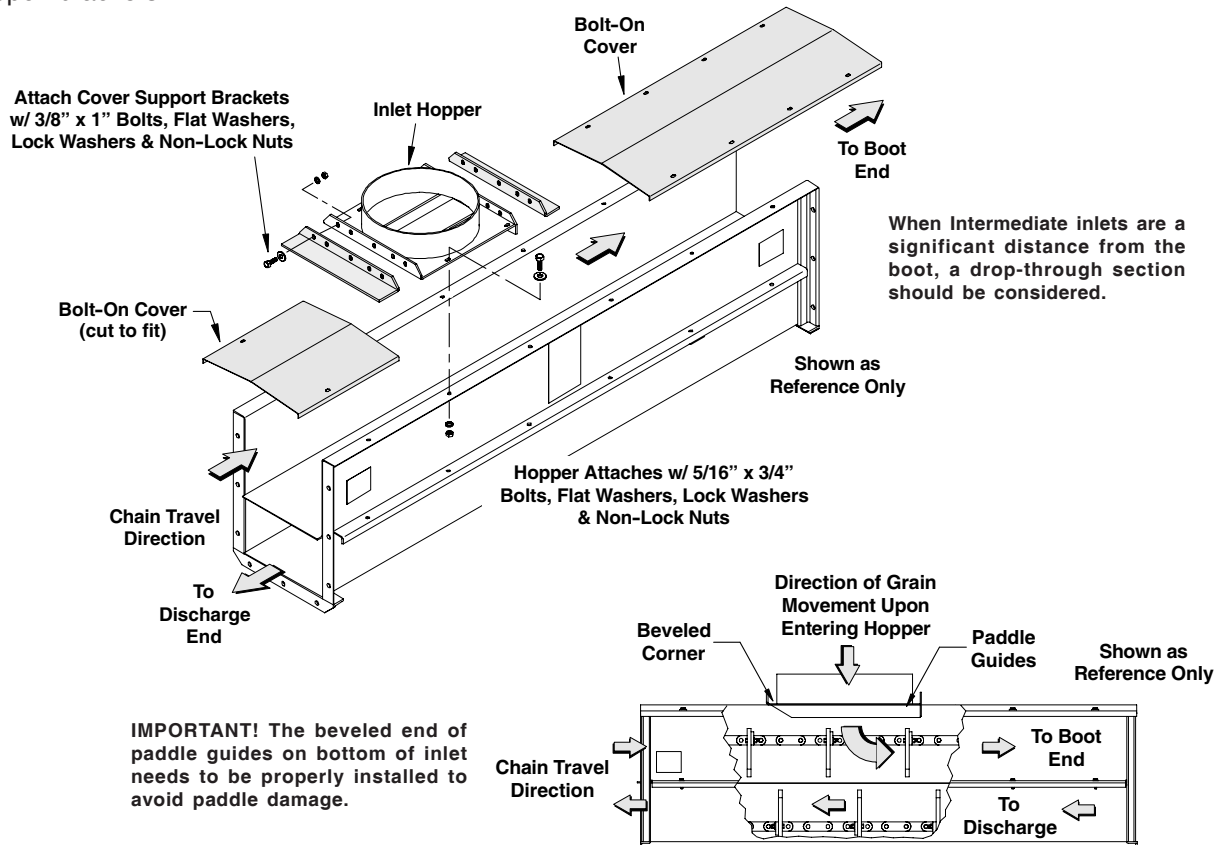

# ASSEMBLY INSTRUCTIONS

## INLET ASSEMBLIES (con't.)

### Inlet Hopper Installation f/ Standard Boot Assembly

Top inlets can also be installed on the boot section. Round inlets can replace either of the hinged covers on the boot assembly (See illustration below).

To replace the long hinged cover at the rear of the boot, loosen the bolts securing the cover to the boot. Remove hinged cover and install the round inlet hopper, securing it with the existing hardware.

To replace the short hinged cover at the front of the boot, remove the hinged cover. Install the cover support brackets to the inlet hopper and secure using 3/8" bolts, flat washers, lock washers and non-lock nuts.

Secure the inlet hopper to the boot using 5/16" x 3/4" bolts, flat washers, lock washers and non-lock nuts.

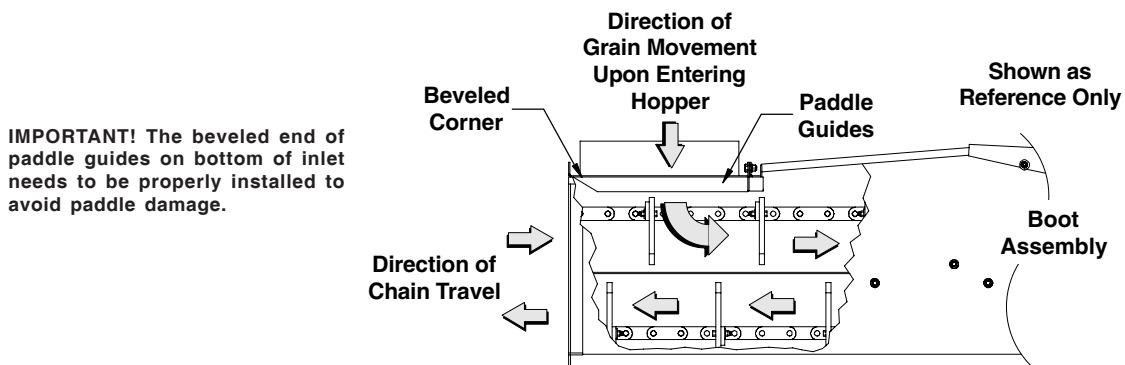
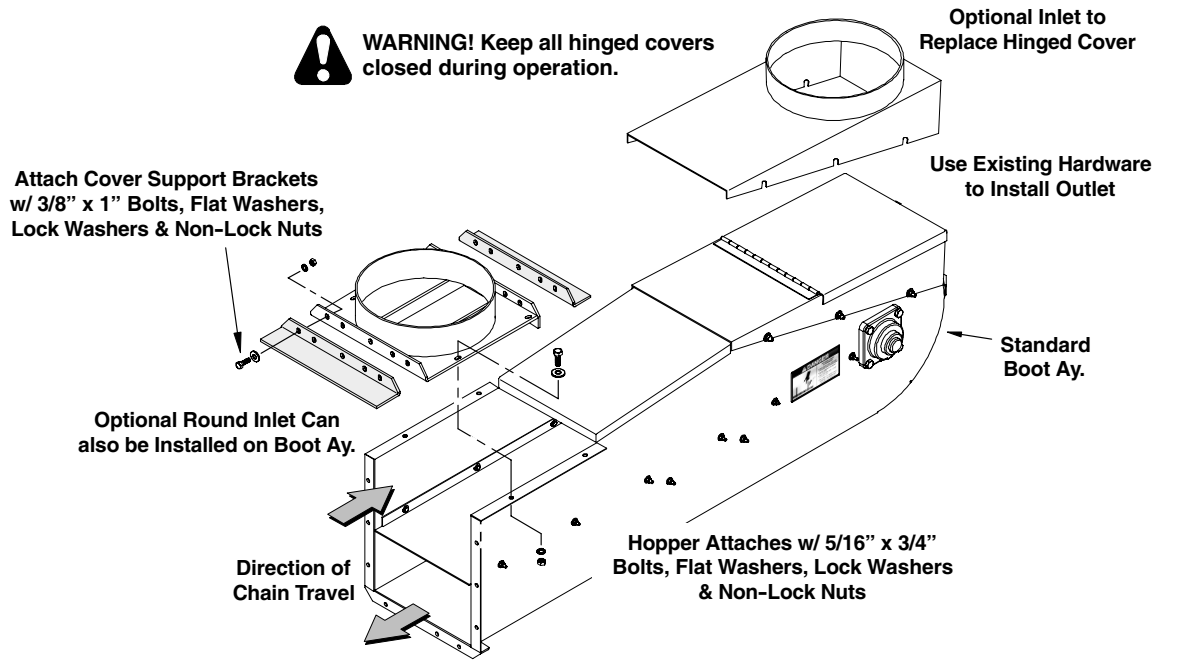

## INLET ASSEMBLIES (con't.)

### Pit Hopper

Pit hoppers are available for drive-over pits. A 5' (1.52 m) and 10' (3.05 m) length is available. One end of the hopper is designed for attachment of the short boot assembly, but can also be adapted to fit a standard trunk section. A flange bracket is available to make this connection (See chart below).

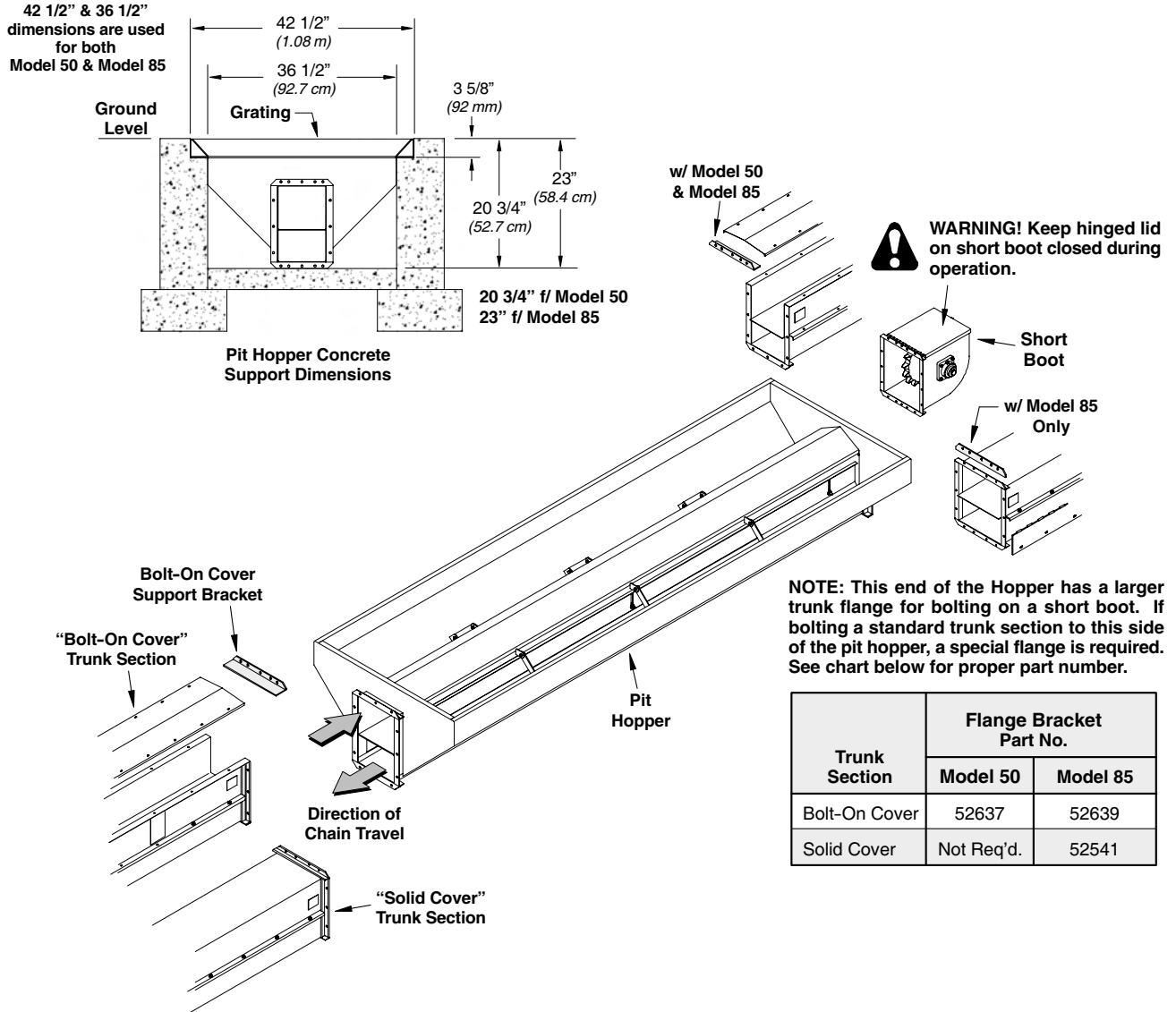

Trunk Section	Flange Bracket Part No.	
	Model 50	Model 85
Bolt-On Cover	52637	52639
Solid Cover	Not Req'd.	52541

On concrete pit dimensions for the length of the hopper, use the 20" (50.8 cm) width of the drive-over grates to ensure that either 3 grates (f/ 5' hopper) or 6 grates (f/ 10' hopper) will fit across the opening.

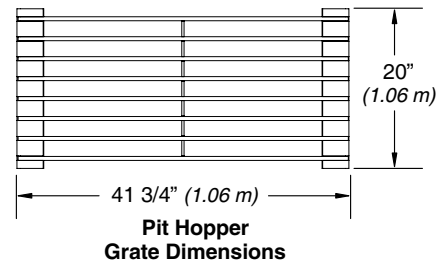
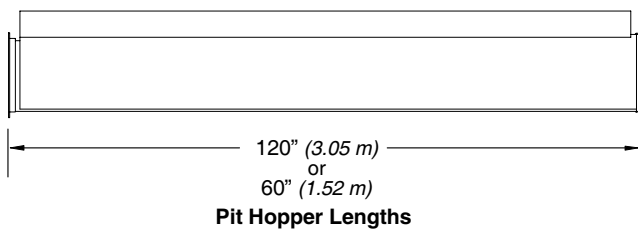

# ASSEMBLY INSTRUCTIONS

## INLET ASSEMBLIES (con't.)

### Flow-Through Hopper

The flow-through hopper should be used at the inlet end of the conveyor when that end is directly above the first discharge point. The bottom gate can be opened for grain to flow without running the conveyor. This method will likely be more convenient than alternative bypass vales and spouts.

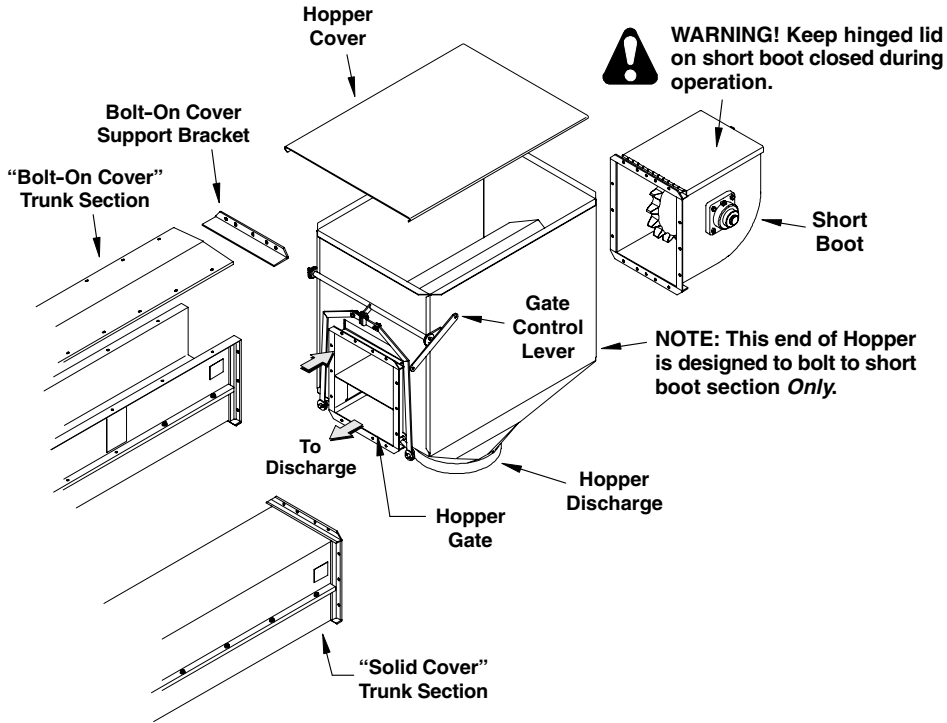

## OUTLETS ASSEMBLY

### Rack & Pinion Controlled Outlet

An intermediate outlet operated by a rack & pinion control device can be used in horizontal and inclined positions.

**IMPORTANT!** When installed on an incline, the outlet should be at the lower end of the conveyor section to insure proper operation of the rack & pinion gate control.

Offset style adapter spout can be used when trunking is horizontal to achieve desired outlet location.

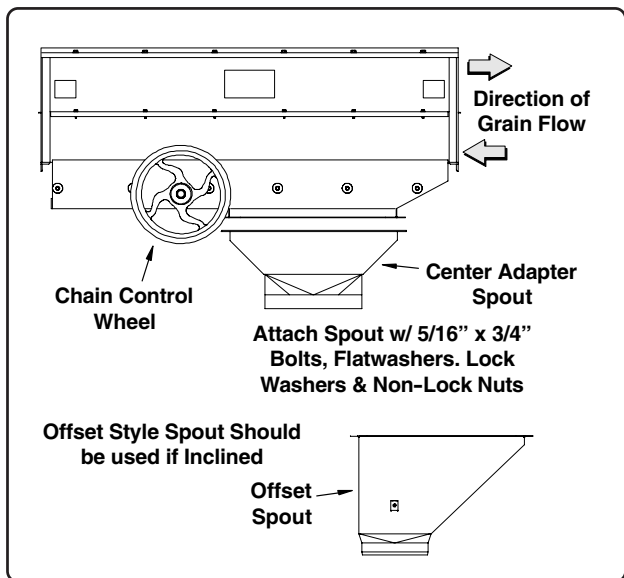

Fig. 12

## OUTLET ASSEMBLIES (con't.)

### Adapter Spout

Adapter spouts for the head drive are available. Model 50 Mass-Ter Mover has a 90° adapter with a 10" (25.4 cm) or 12" (30.5 cm) round opening.

Model 85 Mass-Ter Mover has a 70° and 90° adapter each with a 14" (35.6 cm) round opening.

The adapters are attached using 5/16" x 3/4" bolts, lock washers and non-lock nuts.

**IMPORTANT! When installed on incline units, the adapter spout must be attached as shown in Fig. 13 for grain to discharge properly.**

**If an adapter spout needs to be mounted in another direction than what is shown, it should only be done on horizontal units, not on incline units.**

**It may be necessary to drill additional mounting holes if the spout is mounted in reverse.**

### Optional Bucket Spout

an optional bucket spout is available to help direct the flow of grain.

Place the bucket spout snugly around the adapter spout, slip chain links over the mounting studs on adapter spout and secure with 5/16" flat washers, lock washers and wing nuts (See fig. 13).

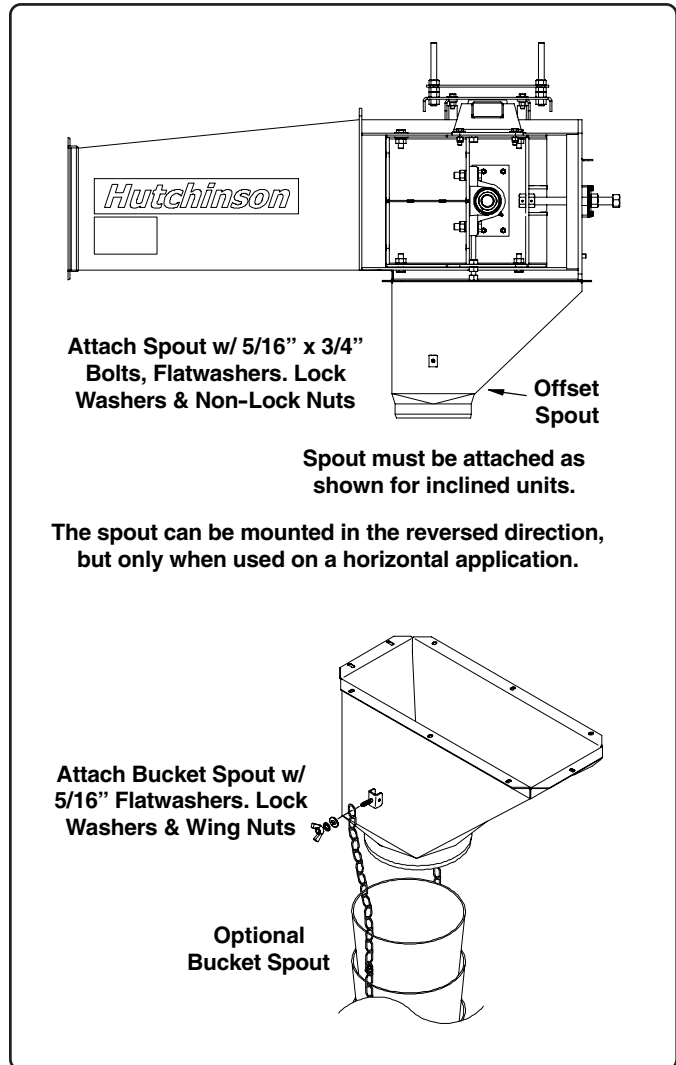

Fig. 13

# PARTS LIST TABLE of CONTENTS

## Model 50 and Model 85 Stationary

### Mass-Ter Mover Conveyor

<b>Decals &amp; Safety Signs .....</b>	<b>P-1</b>
<b>Chain &amp; Paddles .....</b>	<b>P-1</b>
<b>Truss Section (40') .....</b>	<b>P-2</b>
<b>Standard Boot Assembly, Model 50 &amp; Model 85 .....</b>	<b>P-3</b>
<b>Head Section, Model 50 Head Assemblies .....</b>	<b>P-4 to P-13</b>
Head Assembly 1042962 w/ TA0107L15 Reducer .....	P-4 to P-5
Head Assembly 1042963 w/ TA1107H15 Reducer .....	P-6 to P-7
Head Assembly 1042964 w/ TA2115H15 Reducer .....	P-8 to P-9
Head Assembly 1042965 w/ TA3203H15 Reducer .....	P-10 to P-11
Head Assembly 1042966 w/ TA4207H15 Reducer .....	P-12 to P-13
<b>Head Section, Model 85 Head Assemblies .....</b>	<b>P-14 to P-25</b>
Head Assembly 1042956 w/ TA0107L15 Reducer .....	P-14 to P-15
Head Assembly 1042957 w/ TA1107H15 Reducer .....	P-16 to P-17
Head Assembly 1042958 w/ TA2115H15 Reducer .....	P-18 to P-19
Head Assembly 1042959 w/ TA3203H15 Reducer .....	P-20 to P-21
Head Assembly 1042960 w/ TA4207H15 Reducer .....	P-22 to P-23
Head Assembly 1042961 w/ TA5215H15 Reducer .....	P-24 to P-25
<b>Drive Assemblies, Model 50 .....</b>	<b>P-26 to P-35</b>
Drive Assemblies for 1042962 Head Assy. w/ TA0407L15 Reducer .....	P-26 to P-27
Drive Assemblies for 1042963 Head Assy. w/ TA1107H15 Reducer .....	P-28 to P-29
Drive Assemblies for 1042964 Head Assy. w/ TA2115H15 Reducer .....	P-30 to P-31
Drive Assemblies for 1042965 Head Assy. w/ TA3203H15 Reducer .....	P-32 to P-33
Drive Assemblies for 1042966 Head Assy. w/ TA4207H15 Reducer .....	P-34 to P-35
<b>Drive Assemblies, Model 85 .....</b>	<b>P-36 to P-48</b>
Drive Assemblies for 1042956 Head Assy. w/ TA0107L15 Reducer .....	P-36 to P-37
Drive Assemblies for 1042957 Head Assy. w/ TA1107H15 Reducer .....	P-38 to P-39
Drive Assemblies for 1042958 Head Assy. w/ TA2115H15 Reducer .....	P-40 to P-42
Drive Assemblies for 1042959 Head Assy. w/ TA3203H15 Reducer .....	P-43 to P-44
Drive Assemblies for 1042960 Head Assy. w/ TA4207H15 Reducer .....	P-45 to P-47
Drive Assembly for 1042961 Head Assy. w/ TA5215H15 Reducer .....	P-48
<b>Vertical Drive Head Assemblies, Model 50 .....</b>	<b>P-49 to P-54</b>
Vertical Drive Head for 3 HP & 5 HP Units (f/ head assembly 1010116) .....	P-49
Vertical Drive Head for 7 1/2 HP Units (f/ head assembly 1006267) .....	P-50
Vertical Drive Head for 10 HP Units (f/ head assembly 1011594) .....	P-51
Vertical Drive Head for 15 HP Units (f/ head assembly 1012580) .....	P-52
Vertical Drive Head for 20 HP Units (f/ head assembly 1011050) .....	P-53
Vertical Drive Head for 25 HP Units (f/ head assembly 1037258) .....	P-54
<b>Vertical Drive Head Assemblies, Model 85 .....</b>	<b>P-55 to P-57</b>
Vertical Drive Head for 15 HP & 20 HP Units (f/ head assembly 1040633) .....	P-55
Vertical Drive Head for 25 HP & 30 HP Units (f/ head assembly 1040631) .....	P-56
Vertical Drive Head for 40 HP Units (f/ head assembly 1040477) .....	P-57
<b>Boot Drive Assemblies, Model 50 &amp; Model 85 .....</b>	<b>P-58 to P-61</b>
Boot Drive for 5 HP to 20 HP Units (f/ M50 boot assembly 1030729) .....	P-58 to P-59
Boot Drive for 25 HP to 40 HP Units (f/ M85 head assembly 1033241) .....	P-60 to P-61
<b>Corner Assemblies, 30°, 45° &amp; 90°, Model 50 &amp; Model 85 .....</b>	<b>P-62 to P-64</b>
<b>Bin Wells, Center &amp; Intermediate, Model 50 &amp; Model 85 .....</b>	<b>P-65, P-66, P-68</b>
<b>Rack &amp; Pinion Control, Model 50 &amp; Model 85 .....</b>	<b>P-67, P-69</b>
<b>Flow Thru Hopper, Model 50 &amp; Model 85 .....</b>	<b>P-70</b>
<b>Optional Spout Assemblies, 30°, 45° &amp; 90° f/ Model 85 w/ 30" opening .....</b>	<b>P-71</b>
<b>Torque Chart .....</b>	<b>P-72</b>

## SAFETY DECALS & LABELS

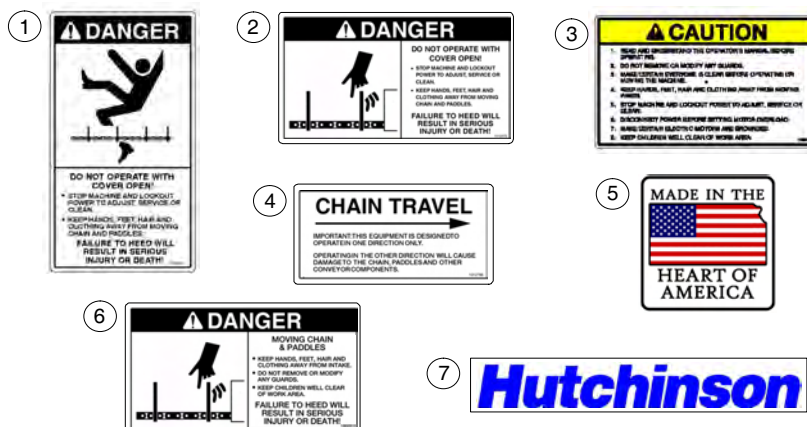

Ref. No.	Part No.	Description
1	1002310	Decal: Danger, Do Not Operate
2	1012872	Decal: Danger, Do Not Operate
3	1002301	Decal: Caution, General Operator
4	1012785	Decal: Chain Travel

Ref. No.	Part No.	Description
5	1041833	Decal: Made in America
6	1002311	Decal: Danger, Moving Paddles
7	1001127	Decal: Hutchinson (rectangle)

## CHAIN & PADDLES

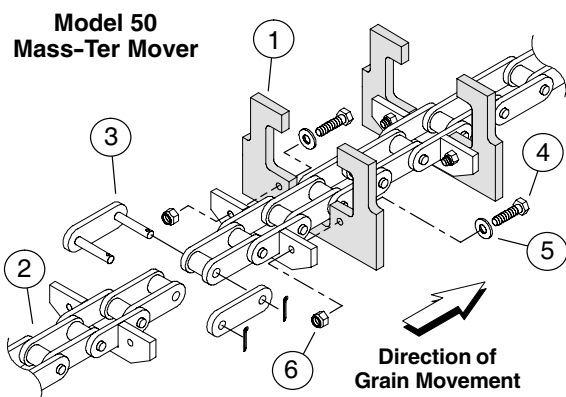

### Model 50 Mass-Ter Mover

Ref. No.	Part No.	Description
1	1005441	Paddle, 3/8" thick UHMW
2	1038004	Chain w/ Brackets, 48 pitch 81X (125 7/32" long)
3	420154	Connecting Link
4	4727-1	Bolt, 5/16"-18 x 1 1/4" G5 PLT
5	33023	Washer, 5/16" Flat PLT
6	33135	Nut, 5/16"-18 Nylon Lock PLT

### Model 85 Mass-Ter Mover

Ref. No.	Part No.	Description
1	1005588	Paddle, 1/2" thick UHMW
2	1038009	Chain w/ Brackets, 48 pitch 81XHH (125 7/32" long)
3	1017077	Connecting Link
4	4736	Bolt, 5/16"-18 x 1 1/2" G5 PLT
5	33023	Washer, 5/16" Flat PLT
6	33135	Nut, 5/16"-18 Nylon Lock PLT

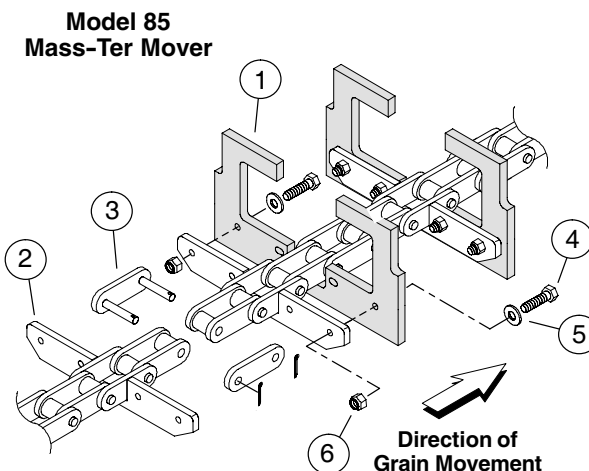

# PARTS LIST

## 40' TRUSS SECTION

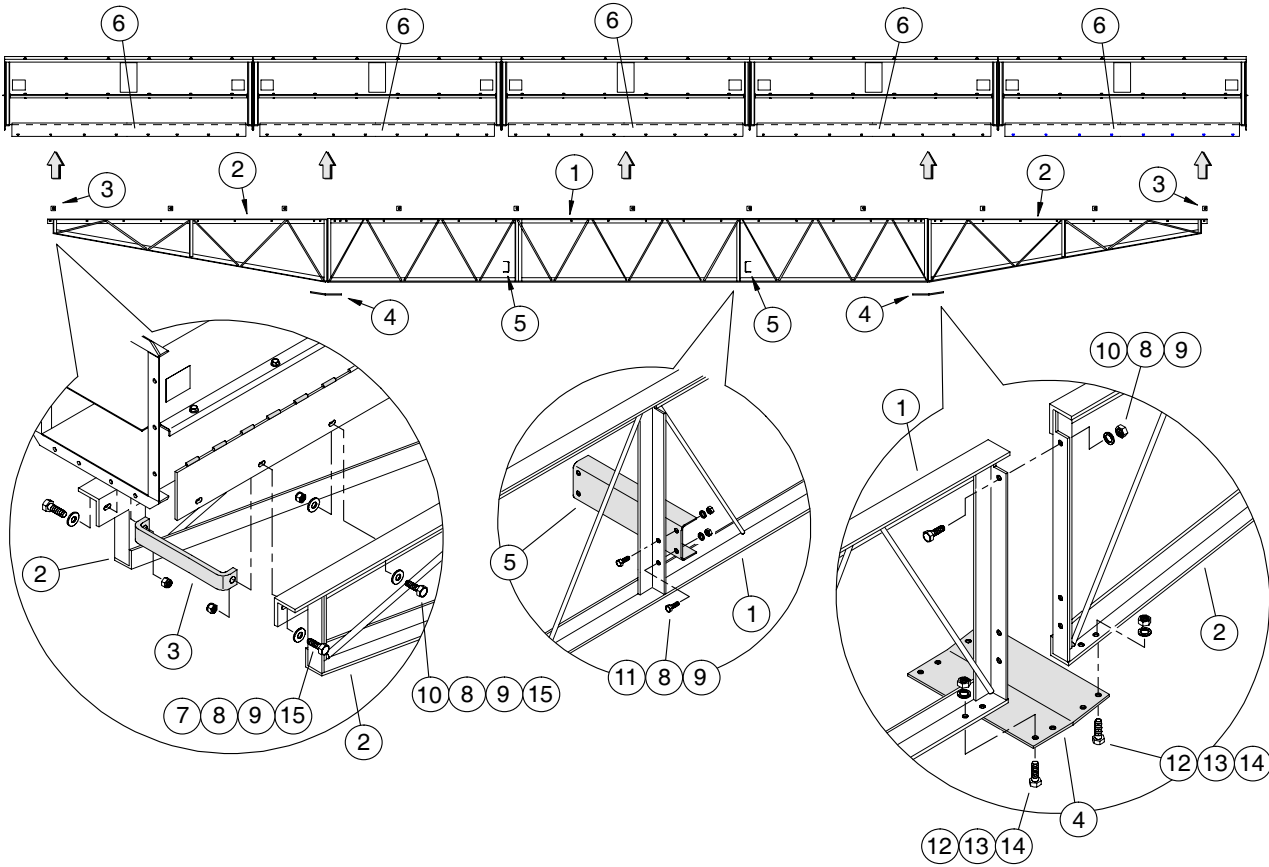

Ref. No.	Part No.	Description	Ref. No.	Part No.	Description
1	6729A1	Truss Side, Center Section	8	D1150	Washer, 3/8" Lock PLT
2	6747A1	Truss Side, Wing Section (left)	9	D1149	Nut, 3/8"-16 Non-Lock PLT
(2)	6748A1	Truss Side, Wing Section (right)	10	33060	Bolt, 3/8"-16 x 1" G5 PLT
3	53947	Spacer, f/ Truss Sides	11	33309	Bolt, 3/8"-16 x 1" G5 PLT
4	53946	Plate, Connecting (wing/center)	12	33082	Bolt, 1/2"-13 x 1 1/4" G5 PLT
5	53945	Plate, Connecting (truss centers)	13	D1143	Washer, 1/2" Lock PLT
6	552630	Plate, Truss Weld-On	14	D1169	Nut, 1/2"-13, Non-Lock
7	33229	Bolt, 3/8"-16 x 1 1/4" G5 PLT	15	33024	Washer, 3/8" Flat PLT

## **STANDARD BOOT & SHORT BOOT ASSEMBLY** **MODEL 50 & MODEL 85**

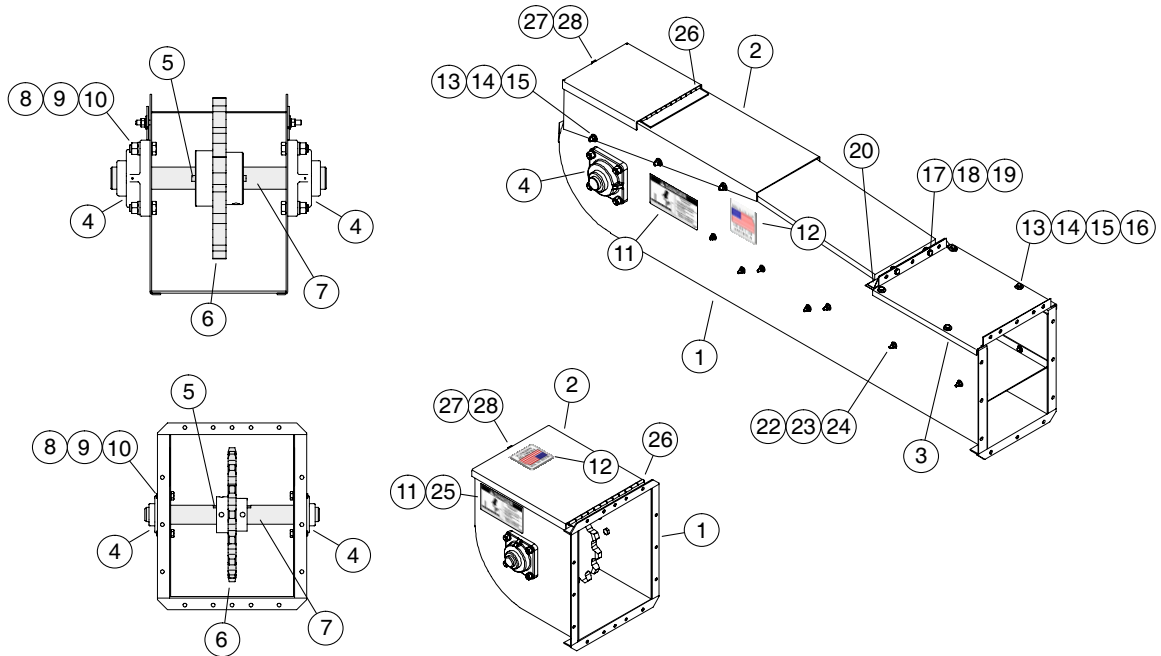

Ref. No.	Part No.	Description	Ref. No.	Part No.	Description
1	1001421	Boot w/ Inlet (Model 50)	8	1002227	Bolt, 1/2"-13 x 1 1/2" G5 PLT
(1)	1001421-AR	Boot w/ Inlet f/ AR Bottom Units	9	D1143	Washer, 1/2" Lock PLT
(1)	1001421-ARS	Boot w/ Inlet f/ ARS Bottom & Side Units	10	D1169	Nut, 1/2"-13 Non-Lock PLT
(1)	1001415	Short Boot (Model 50)	11	1002311	Decal, Danger: Moving Chain...
(1)	1001415-AR	Short Boot f/ AR Bottom Units	12	1041833	Decal, USA Flag
(1)	1001415-ARS	Short Boot f/ ARS Bottom & Side Units	13	33023	Washer, 5/16" Flat PLT
(1)	1001422	Boot w/ Inlet (Model 85)	14	33144	Washer, 5/16" Lock PLT
(1)	1001422-AR	Boot w/ Inlet f/ AR Bottom Units	15	33151	Nut, 5/16"-18 Non-Lock PLT
(1)	1001422-ARS	Boot w/ Inlet f/ ARS Bottom & Side Units	16	4701-1	Bolt, 5/16"-18 x 3/4" G5 PLT
(1)	1001416	Short Boot (Model 85)	17	D1149	Nut, 3/8"-16 Non-Lock PLT
(1)	1001416-AR	Short Boot f/ AR Bottom Units	18	D1150	Washer, 3/8" Lock PLT
(1)	1001416-ARS	Short Boot f/ ARS Bottom & Side Units	19	33309	Bolt, 3/8"-16 x 3/4" G5 PLT
2	61925	Cover, Inspection, Stnd. Boot (M50)	20	52546	Flange (Model 50)
(2)	61840	Cover, Inspection, Stnd. Boot (M85)	(20)	52519	Flange (Model 85)
(2)	52596	Cover, Inspection, Short Boot (M50)	21	53276	Paddle Guide, left (not shown)
(2)	52518	Cover, Inspection, Short Boot (M85)	(21)	53277	Paddle Guide, right (not shown)
3	52591	Cover (Model 50)	22	4618-1	Bolt, 1/4"-20 x 1" G5 PLT
(3)	52520	Cover (Model 85)	23	33022	Washer, 1/4" Flat PLT
4	1010A	Bearing, 1 1/2" 4-hole Flange	24	4003	Nut, 1/4"-20 Nylon Lock PLT
5	4073A1	Key, 3/8" sq x 3" long (Model 50)	25	1002310	Decal, Danger: Do Not Operate... w/ Model 50 Short Boot
(5)	4021L1	Key, 1/2" sq x 2.75" long (Model 85)	26	4145A1	Hinge, w/ Model 50 Short Boot
6	1005566	Sprocket, 81C 12 T (Model 50)	(26)	52515	Hinge, w/ Model 85 Short Boot
(6)	420092	Sprocket, 81C 16T (Model 85)	27	4017A1	Strike Clamp
7	50706	Shaft, Tail (Model 50)	28	4089A1	Clip f/ Strike Clamp
(7)	553595	Shaft, Tail (Model 85)			

**All items listed are used on both the Model 50 and Model 85 Units unless otherwise noted.**

# PARTS LIST

## HEAD SECTION, MODEL 50

Head Assembly 1042962

M50 Assembly f/ TA0107L15 Reducer  
f/ Drive Assemblies

M50300C5, M50305C5, M50310C5,  
M50311C5, M50315C5, M50316C5

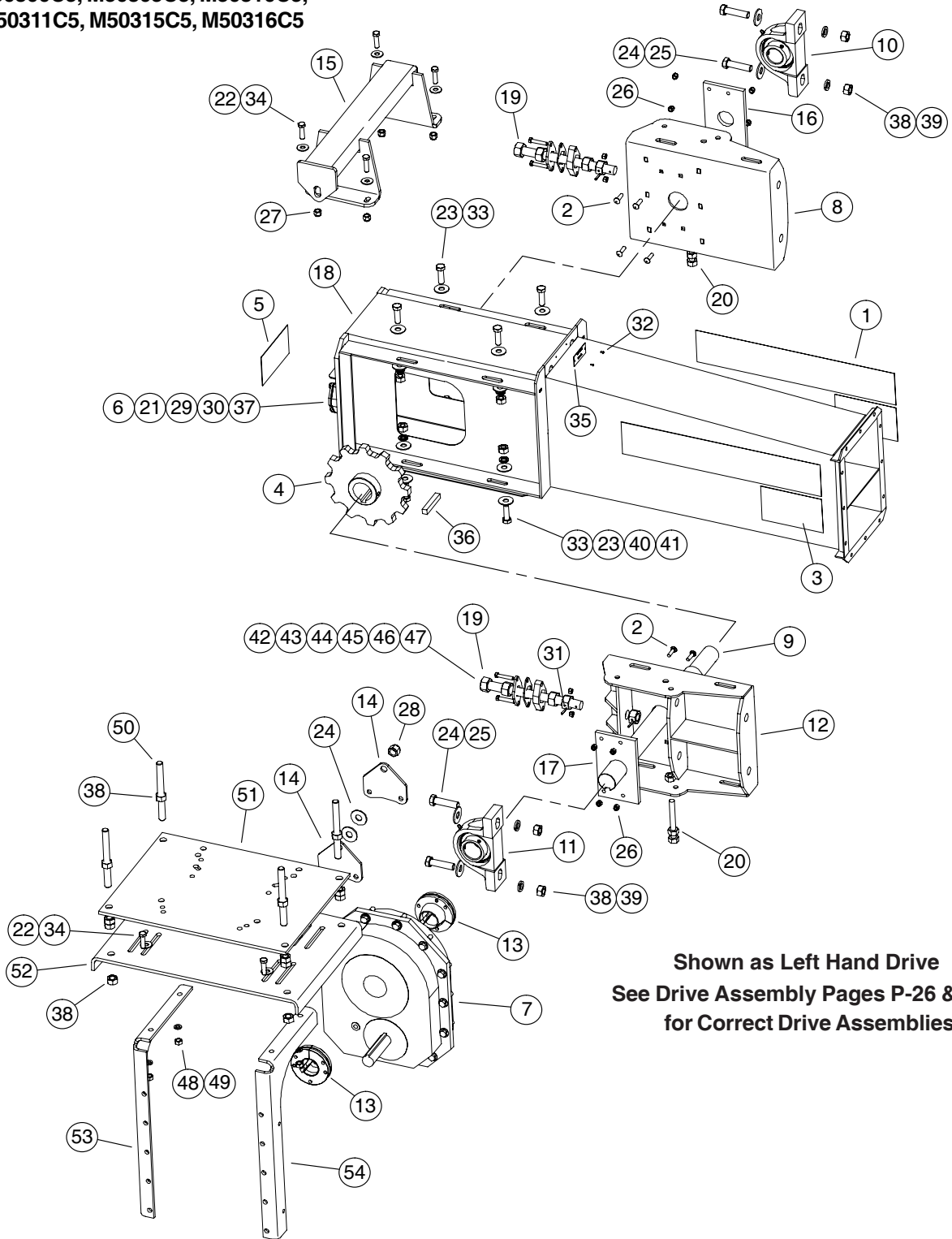

Shown as Left Hand Drive  
See Drive Assembly Pages P-26 & P-27  
for Correct Drive Assemblies

## HEAD SECTION, MODEL 50

**Head Assembly 1042962  
M50 Assembly f/ TA0107L15 Reducer  
f/ Drive Assemblies**

**M50300C5, M50305C5, M50310C5,  
M50311C5, M50315C5, M50316C5**

**The Head Assembly is also available with  
AR and ARS Plating.**

Ref. No.	Part No.	Description	Ref. No.	Part No.	Description
1	1001125	Decal, Hutchinson (rectangle)	28	33140	Nut, 3/4"-10 Nylon Lock PLT
2	1002248	Bolt, 3/8"-16 x 1 1/4" Carriage G5 PLT	29	33142	Washer, 3/16" Lock PLT
3	1002301	Decal, Caution: General Operator	30	33149	Nut, 3/16" Non-Lock PLT
4	1005566	Sprocket, 81C 12T, 1 1/2" bore	31	33158	Roll Pin, 3/16" x 1 1/4" long
5	1012872	Decal, Danger: Do Not Operate...	32	33188	Rivet, 1/8" Drive
6	1017092	Bolt, 3/16" x 1 1/2" Stove G5	33	33244	Bolt, 5/8"-11 x 2" G5 PLT
7	1042850	Reducer, TA0107L15 f/ Torque Arm II	34	33247	Bolt, 1/2"-13 x 1 3/4" G5 PLT
8	1043010	Slide Weldment, 1 1/2" Brng	35	34687	Serial Plate, Hutchinson/Mayrath
9	1042870	Shaft, f/ Head w/ TA0107L15 Reducer	36	4073A1	Key, 3/8" sq x 3" long
10	1042884	Bearing, Pillow Block (1 1/2")	37	90040	Fastener, Quick Release
11	1042884	Bearing, Pillow Block (1 1/2")	38	D1152	Nut, 3/4"-10 Non-Lock PLT
12	1043010	Slide Weldment, 1 1/2" Brng	39	D1153	Washer, 3/4" Lock PLT
13	1042951	Kit, Bushing, f/ TA0107L15 Reducer	40	D1170	Nut, 5/8"-11 Non-Lock PLT
14	1042970	Plate, Torque Arm, f/ TA0107L15 Rdcr	41	D1171	Washer, 5/8" Lock PLT
15	1042994	Torque Arm Weldment	42	1043407	Plate, Spacer f/ 1" Nut Retainer
16	1043044	Seal, Shaft (1 1/2" UMHW)	43	1043435	Plate, Thin Spacer f/ 1" Nut Rtrn.
17	1043044	Seal, f/ 1 1/2" Shaft	44	1043408	Retainer Plate f/ 1" Nut
18	1043050	Head Housing Weldment	45	D1158	Nut, 1"-8 Non-Lock PLT
19	1043078	Adjustment Rod	46	1002199	Bolt, 3/8"-16 x 2" G5 PLT
20	1043183	Rod, Bearing Slide Adjustment	47	1004783	Nut, 3/8"-16 Side Depress PLT
21	33021	Washer, 3/16" Flat PLT	48	D1143	Washer, 1/2" Lock PLT
22	33025	Washer, 1/2" Flat PLT	49	D1169	Nut, 1/2"-13 Non-Lock PLT
23	33026	Washer, 5/8" Flat PLT	50	1039771	Rod, Radius Arm Tension
24	33027	Washer, 3/4" Flat PLT	51	1043507	Plate, Motor Mount f/ TA0107L15
25	33112	Bolt, 3/4"-10 x 3" G5 PLT	52	1043508	Support, Motor Mount
26	33136	Nut, 3/8"-16 Nylon Lock PLT	53	1043488	Angle, Motor Mount Support (left)
27	33138	Nut, 1/2"-13 Nylon Lock PLT	54	1043489	Angle, Motor Mount Support (right)

**See Drive Assembly Pages P-26 & P-27  
for Correct Drive Assemblies**

**Note: Parts Illustration is Shown for the Standard Left Hand Drive. For Right Hand Drive Units, some Components may be Reversed, Particularly Items, 8, 10, 11, 12, 16 & 17.**

**Note: If Item 17 (Shaft Seal) is Larger than Item 16 (Shaft Seal) the Larger Seal will be Located on the Reducer Side.**

# PARTS LIST

## HEAD SECTION, MODEL 50

Head Assembly 1042963  
 M50 Assembly f/ TA1107H15 Reducer  
 f/ Drive Assemblies  
 M50301C5, M50306C5, M50307C5,  
 M50312C5, M50317C5,  
 M50318C5

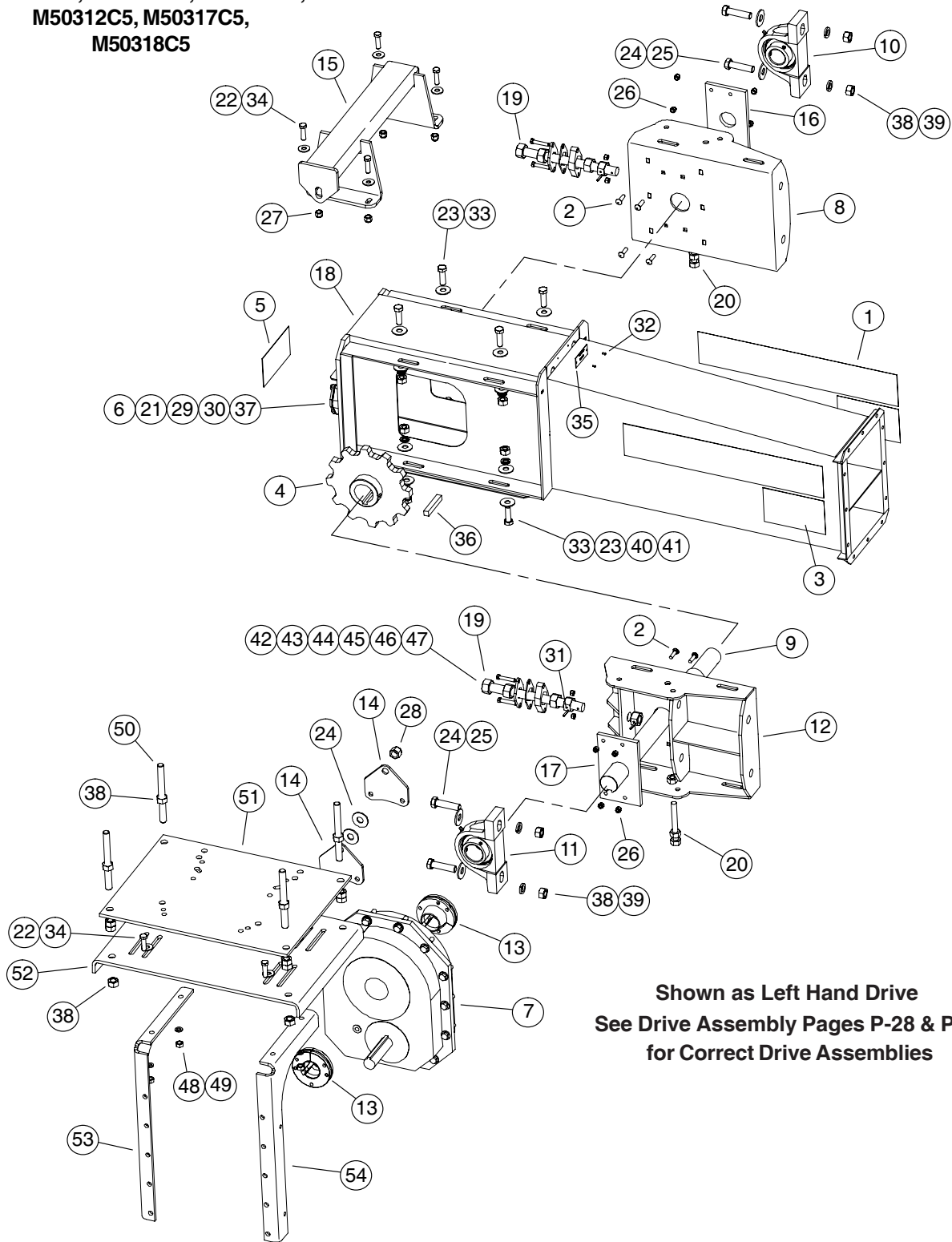

**Shown as Left Hand Drive  
 See Drive Assembly Pages P-28 & P-29  
 for Correct Drive Assemblies**

## **HEAD SECTION, MODEL 50**

**Head Assembly 1042963  
M50 Assembly f/ TA1107H15 Reducer  
f/ Drive Assemblies  
M50301C5, M50306C5, M50307C5,  
M50312C5, M50317C5,  
M50318C5**

**The Head Assembly is also available with  
AR and ARS Plating.**

Ref. No.	Part No.	Description	Ref. No.	Part No.	Description
1	1001125	Decal, Hutchinson (rectangle)	28	33140	Nut, 3/4"-10 Nylon Lock PLT
2	1002248	Bolt, 3/8"-16 x 1 1/4" Carriage G5 PLT	29	33142	Washer, 3/16" Lock PLT
3	1002301	Decal, Caution: General Operator	30	33149	Nut, 3/16" Non-Lock PLT
4	1005565	Sprocket, 81C 12T, 2" bore	31	33158	Roll Pin, 3/16" x 1 1/4" long
5	1012872	Decal, Danger: Do Not Operate...	32	33188	Rivet, 1/8" Drive
6	1017092	Bolt, 3/16" x 1 1/2" Stove G5	33	33244	Bolt, 5/8"-11 x 2" G5 PLT
7	1042851	Reducer, TA1107H15 f/ Torque Arm II	34	33247	Bolt, 1/2"-13 x 1 3/4" G5 PLT
8	1043010	Slide Weldment, 1 1/2" Brng	35	34687	Serial Plate, Hutchinson/Mayrath
9	1042872	Shaft, f/ Head w/ TA1107H15 Reducer	36	4021L1	Key, 1/2" sq x 2 3/4" long
10	1042884	Bearing, Pillow Block (1 1/2")	37	90040	Fastener, Quick Release
11	1042884	Bearing, Pillow Block (1 1/2")	38	D1152	Nut, 3/4"-10 Non-Lock PLT
12	1043010	Slide Weldment, 1 1/2" Brng	39	D1153	Washer, 3/4" Lock PLT
13	1041602	Kit, Bushing, f/ TA1107H15 Reducer	40	D1170	Nut, 5/8"-11 Non-Lock PLT
14	1042971	Plate, Torque Arm, f/ TA1107H15 Rdcr	41	D1171	Washer, 5/8" Lock PLT
15	1042995	Torque Arm Weldment	42	1043407	Plate, Spacer f/ 1" Nut Retainer
16	1043044	Seal, Shaft (1 1/2" UMHW)	43	1043435	Plate, Thin Spacer f/ 1" Nut Rtrn.
17	1043044	Seal, f/ 1 1/2" Shaft	44	1043408	Retainer Plate f/ 1" Nut
18	1043050	Head Housing Weldment	45	D1158	Nut, 1"-8 Non-Lock PLT
19	1043078	Adjustment Rod	46	1002199	Bolt, 3/8"-16 x 2" G5 PLT
20	1043183	Rod, Bearing Slide Adjustment	47	1004783	Nut, 3/8"-16 Side Depress PLT
21	33021	Washer, 3/16" Flat PLT	48	D1143	Washer, 1/2" Lock PLT
22	33025	Washer, 1/2" Flat PLT	49	D1169	Nut, 1/2"-13 Non-Lock PLT
23	33026	Washer, 5/8" Flat PLT	50	1039771	Rod, Radius Arm Tension
24	33027	Washer, 3/4" Flat PLT	51	1043509	Plate, Motor Mount f/ TA1107H15
25	33112	Bolt, 3/4"-10 x 3" G5 PLT	52	1043510	Support, Motor Mount
26	33136	Nut, 3/8"-16 Nylon Lock PLT	53	1043490	Angle, Motor Mount Support (left)
27	33138	Nut, 1/2"-13 Nylon Lock PLT	54	1043491	Angle, Motor Mount Support (rght)

**See Drive Assembly Pages P-28 & P-29  
for Correct Drive Assemblies**

**Note: Parts Illustration is Shown for the Standard Left Hand Drive. For Right Hand Drive Units, some Components may be Reversed, Particularly Items, 8, 10, 11, 12, 16 & 17.**

**Note: If Item 17 (Shaft Seal) is Larger than Item 16 (Shaft Seal) the Larger Seal will be Located on the Reducer Side.**

# PARTS LIST

## HEAD SECTION, MODEL 50

Head Assembly 1042964

M50 Assembly f/ TA2115H15 Reducer  
f/ Drive Assemblies

M50302C5, M50308C5, M50313C5,  
M50314C5, M50319C5

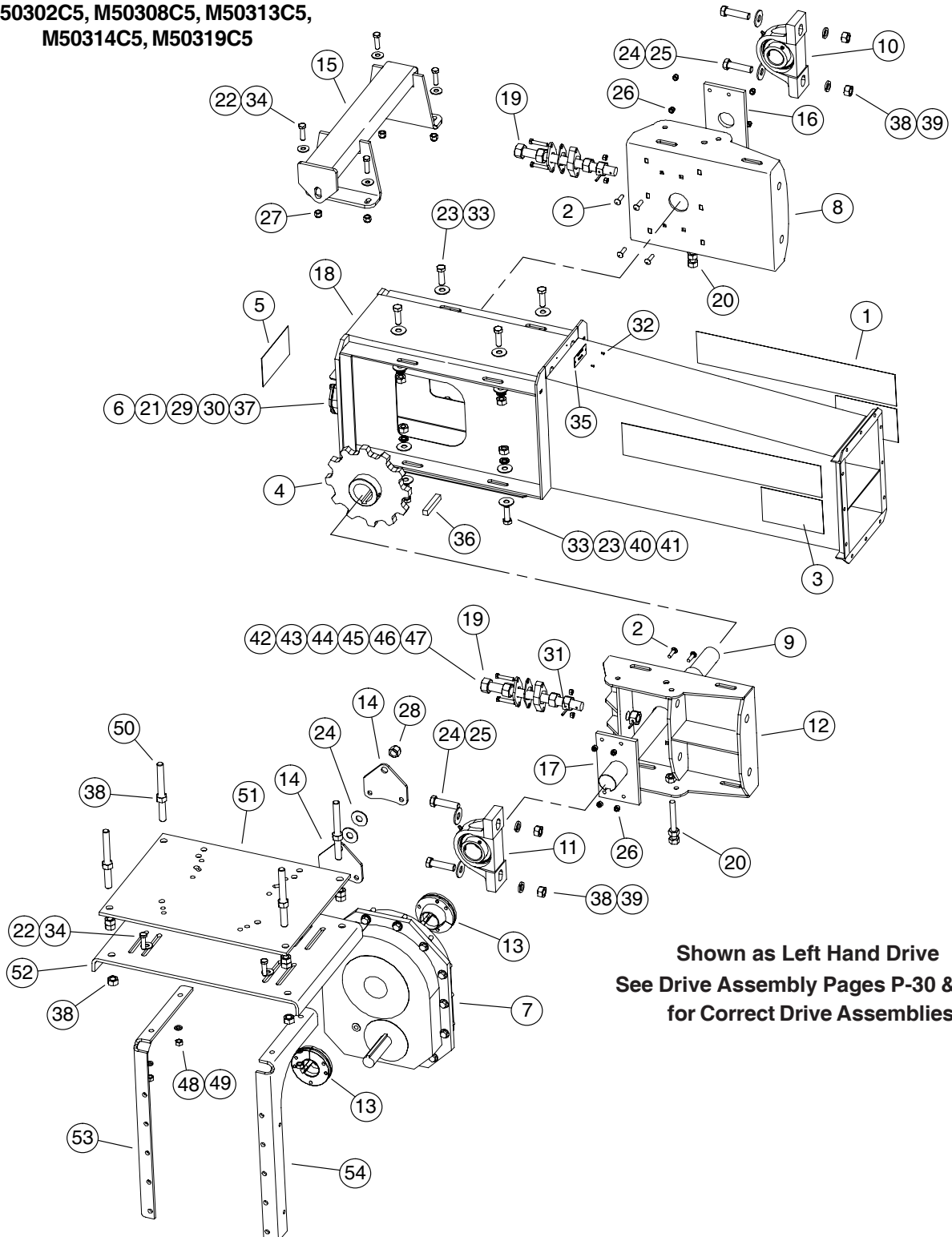

**Shown as Left Hand Drive  
See Drive Assembly Pages P-30 & P-31  
for Correct Drive Assemblies**

## HEAD SECTION, MODEL 50

**Head Assembly 1042964**  
**M50 Assembly f/ TA2115H15 Reducer**  
**f/ Drive Assemblies**  
**M50302C5, M50308C5, M50313C5,**  
**M50314C5, M50319C5**

**The Head Assembly is also available with**  
**AR and ARS Plating.**

Ref. No.	Part No.	Description	Ref. No.	Part No.	Description
1	1001125	Decal, Hutchinson (rectangle)	28	33140	Nut, 3/4"-10 Nylon Lock PLT
2	1002248	Bolt, 3/8"-16 x 1 1/4" Carriage G5 PLT	29	33142	Washer, 3/16" Lock PLT
3	1002301	Decal, Caution: General Operator	30	33149	Nut, 3/16" Non-Lock PLT
4	1005564	Sprocket, 81C 12T, 2 7/16" bore	31	33158	Roll Pin, 3/16" x 1 1/4" long
5	1012872	Decal, Danger: Do Not Operate...	32	33188	Rivet, 1/8" Drive
6	1017092	Bolt, 3/16" x 1 1/2" Stove G5	33	33244	Bolt, 5/8"-11 x 2" G5 PLT
7	1042852	Reducer, TA2115H15 f/ Torque Arm II	34	33247	Bolt, 1/2"-13 x 1 3/4" G5 PLT
8	1043010	Slide Weldment, 1 1/2" Brng	35	34687	Serial Plate, Hutchinson/Mayrath
9	1042874	Shaft, f/ Head w/ TA2115H15 Reducer	36	53060	Key, 5/8" sq x 3 3/4" long
10	1042884	Bearing, Pillow Block (1 1/2")	37	90040	Fastener, Quick Release
11	1042885	Bearing, Pillow Block (2")	38	D1152	Nut, 3/4"-10 Non-Lock PLT
12	1042930	Slide Weldment, 2 1/4" Brng	39	D1153	Washer, 3/4" Lock PLT
13	1040864	Kit, Bushing, f/ TA2115H15 Reducer	40	D1170	Nut, 5/8"-11 Non-Lock PLT
14	1042972	Plate, Torque Arm, f/ TA2115H15 Rdcr	41	D1171	Washer, 5/8" Lock PLT
15	1042996	Torque Arm Weldment	42	1043407	Plate, Spacer f/ 1" Nut Retainer
16	1043044	Seal, Shaft (1 1/2" UMHW)	43	1043435	Plate, Thin Spacer f/ 1" Nut Rtnr.
17	1043045	Seal, f/ 2" Shaft	44	1043408	Retainer Plate f/ 1" Nut
18	1043050	Head Housing Weldment	45	D1158	Nut, 1"-8 Non-Lock PLT
19	1043078	Adjustment Rod	46	1002199	Bolt, 3/8"-16 x 2" G5 PLT
20	1043183	Rod, Bearing Slide Adjustment	47	1004783	Nut, 3/8"-16 Side Depress PLT
21	33021	Washer, 3/16" Flat PLT	48	D1143	Washer, 1/2" Lock PLT
22	33025	Washer, 1/2" Flat PLT	49	D1169	Nut, 1/2"-13 Non-Lock PLT
23	33026	Washer, 5/8" Flat PLT	50	1039771	Rod, Radius Arm Tension
24	33027	Washer, 3/4" Flat PLT	51	1043511	Plate, Motor Mount f/ TA2115H15
25	33112	Bolt, 3/4"-10 x 3" G5 PLT	52	1043512	Support, Motor Mount
26	33136	Nut, 3/8"-16 Nylon Lock PLT	53	1043492	Angle, Motor Mount Support (left)
27	33138	Nut, 1/2"-13 Nylon Lock PLT	54	1043493	Angle, Motor Mount Support (rght)

**See Drive Assembly Pages P-30 & P-31**  
**for Correct Drive Assemblies**

**Note: Parts Illustration is Shown for the Standard Left Hand Drive. For Right Hand Drive Units, some Components may be Reversed, Particularly Items, 8, 10, 11, 12, 16 & 17.**

**Note: If Item 17 (Shaft Seal) is Larger than Item 16 (Shaft Seal) the Larger Seal will be Located on the Reducer Side.**

# PARTS LIST

## HEAD SECTION, MODEL 50

Head Assembly 1042965  
 M50 Assembly f/ TA3203H15 Reducer  
 f/ Drive Assemblies  
 M50303C5, M50309C5, M51305C5,  
 M51311C5, M51316C5

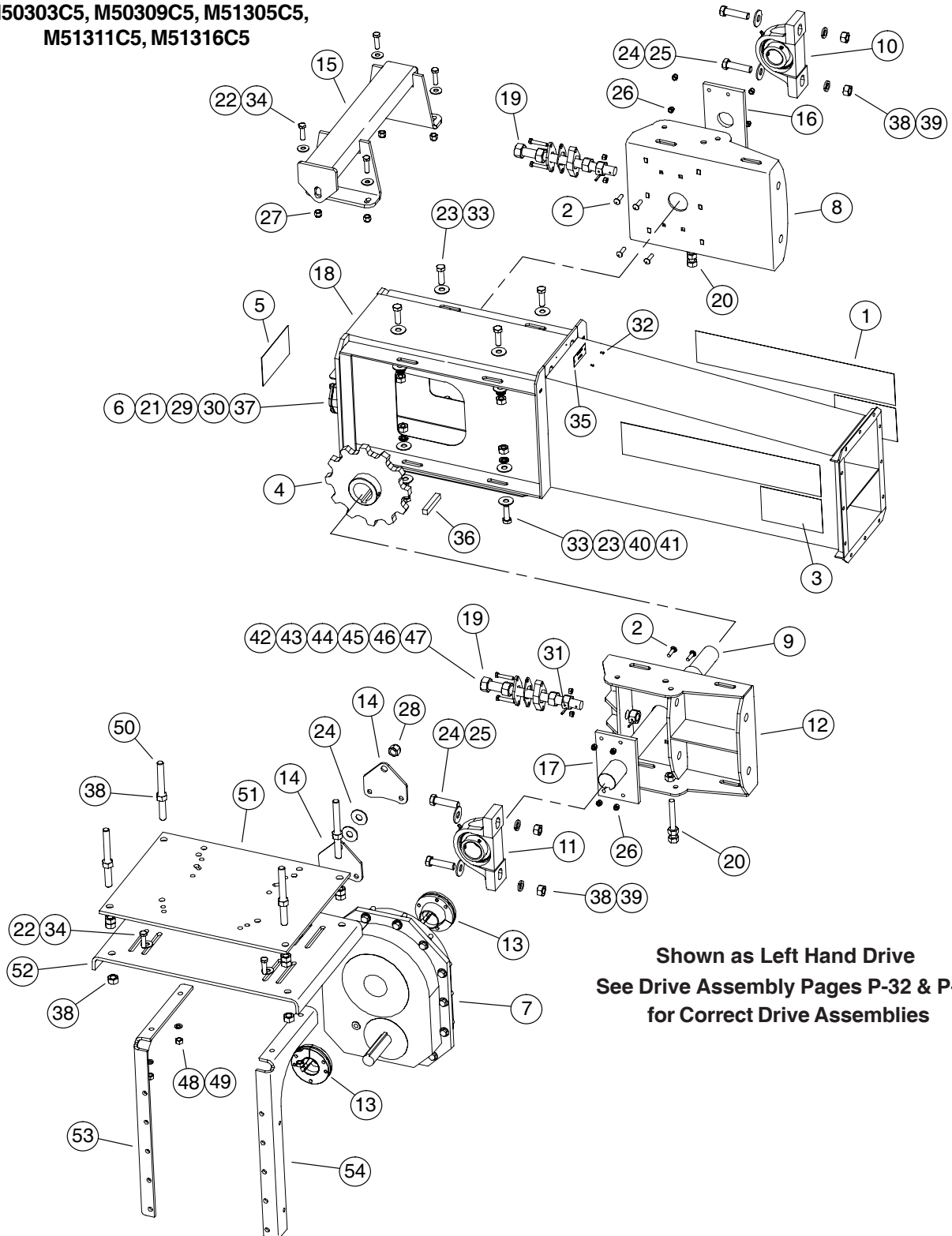

**Shown as Left Hand Drive  
 See Drive Assembly Pages P-32 & P-33  
 for Correct Drive Assemblies**

## HEAD SECTION, MODEL 50

**Head Assembly 1042965**  
**M50 Assembly f/ TA3203H15 Reducer**  
**f/ Drive Assemblies**  
**M50303C5, M50309C5, M51305C5,**  
**M51311C5, M51316C5**

**The Head Assembly is also available with**  
**AR and ARS Plating.**

Ref. No.	Part No.	Description	Ref. No.	Part No.	Description
1	1001125	Decal, Hutchinson (rectangle)	28	33140	Nut, 3/4"-10 Nylon Lock PLT
2	1002248	Bolt, 3/8"-16 x 1 1/4" Carriage G5 PLT	29	33142	Washer, 3/16" Lock PLT
3	1002301	Decal, Caution: General Operator	30	33149	Nut, 3/16" Non-Lock PLT
4	1005564	Sprocket, 81C 12T, 2 7/16" bore	31	33158	Roll Pin, 3/16" x 1 1/4" long
5	1012872	Decal, Danger: Do Not Operate...	32	33188	Rivet, 1/8" Drive
6	1017092	Bolt, 3/16" x 1 1/2" Stove G5	33	33244	Bolt, 5/8"-11 x 2" G5 PLT
7	1036873	Reducer, TA3203H15 f/ Torque Arm II	34	33247	Bolt, 1/2"-13 x 1 3/4" G5 PLT
8	1042930	Slide Weldment, 2 1/4" Brng	35	34687	Serial Plate, Hutchinson/Mayrath
9	1042876	Shaft, f/ Head w/ TA3203H15 Reducer	36	53060	Key, 5/8" sq x 3 3/4" long
10	1042885	Bearing, Pillow Block (2")	37	90040	Fastener, Quick Release
11	1042888	Bearing, Pillow Block (2 1/4")	38	D1152	Nut, 3/4"-10 Non-Lock PLT
12	1042930	Slide Weldment, 2 1/4" Brng	39	D1153	Washer, 3/4" Lock PLT
13	1042952	Kit, Bushing, f/ TA3203H15 Reducer	40	D1170	Nut, 5/8"-11 Non-Lock PLT
14	1042973	Plate, Torque Arm, f/ TA3203H15 Rdcr	41	D1171	Washer, 5/8" Lock PLT
15	1042997	Torque Arm Weldment	42	1043407	Plate, Spacer f/ 1" Nut Retainer
16	1043045	Seal, Shaft (2" UMHW)	43	1043435	Plate, Thin Spacer f/ 1" Nut Rtnr.
17	1043046	Seal, f/ 2 1/4" Shaft	44	1043408	Retainer Plate f/ 1" Nut
18	1043050	Head Housing Weldment	45	D1158	Nut, 1"-8 Non-Lock PLT
19	1043078	Adjustment Rod	46	1002199	Bolt, 3/8"-16 x 2" G5 PLT
20	1043183	Rod, Bearing Slide Adjustment	47	1004783	Nut, 3/8"-16 Side Depress PLT
21	33021	Washer, 3/16" Flat PLT	48	D1143	Washer, 1/2" Lock PLT
22	33025	Washer, 1/2" Flat PLT	49	D1169	Nut, 1/2"-13 Non-Lock PLT
23	33026	Washer, 5/8" Flat PLT	50	1039771	Rod, Radius Arm Tension
24	33027	Washer, 3/4" Flat PLT	51	1043513	Plate, Motor Mount f/ TA3203H15
25	33112	Bolt, 3/4"-10 x 3" G5 PLT	52	1043514	Support, Motor Mount
26	33136	Nut, 3/8"-16 Nylon Lock PLT	53	1043494	Angle, Motor Mount Support (left)
27	33138	Nut, 1/2"-13 Nylon Lock PLT	54	1043495	Angle, Motor Mount Support (right)

**See Drive Assembly Pages P-32 & P-33**  
**for Correct Drive Assemblies**

**Note: Parts Illustration is Shown for the Standard Left Hand Drive. For Right Hand Drive Units, some Components may be Reversed, Particularly Items, 8, 10, 11, 12, 16 & 17.**

**Note: If Item 17 (Shaft Seal) is Larger than Item 16 (Shaft Seal) the Larger Seal will be Located on the Reducer Side.**

# PARTS LIST

## **HEAD SECTION, MODEL 50**

Head Assembly 1042966  
M50 Assembly f/ TA4207H15 Reducer  
f/ Drive Assemblies  
M51317C5, M51321C5, M51322C5,  
M51323C5

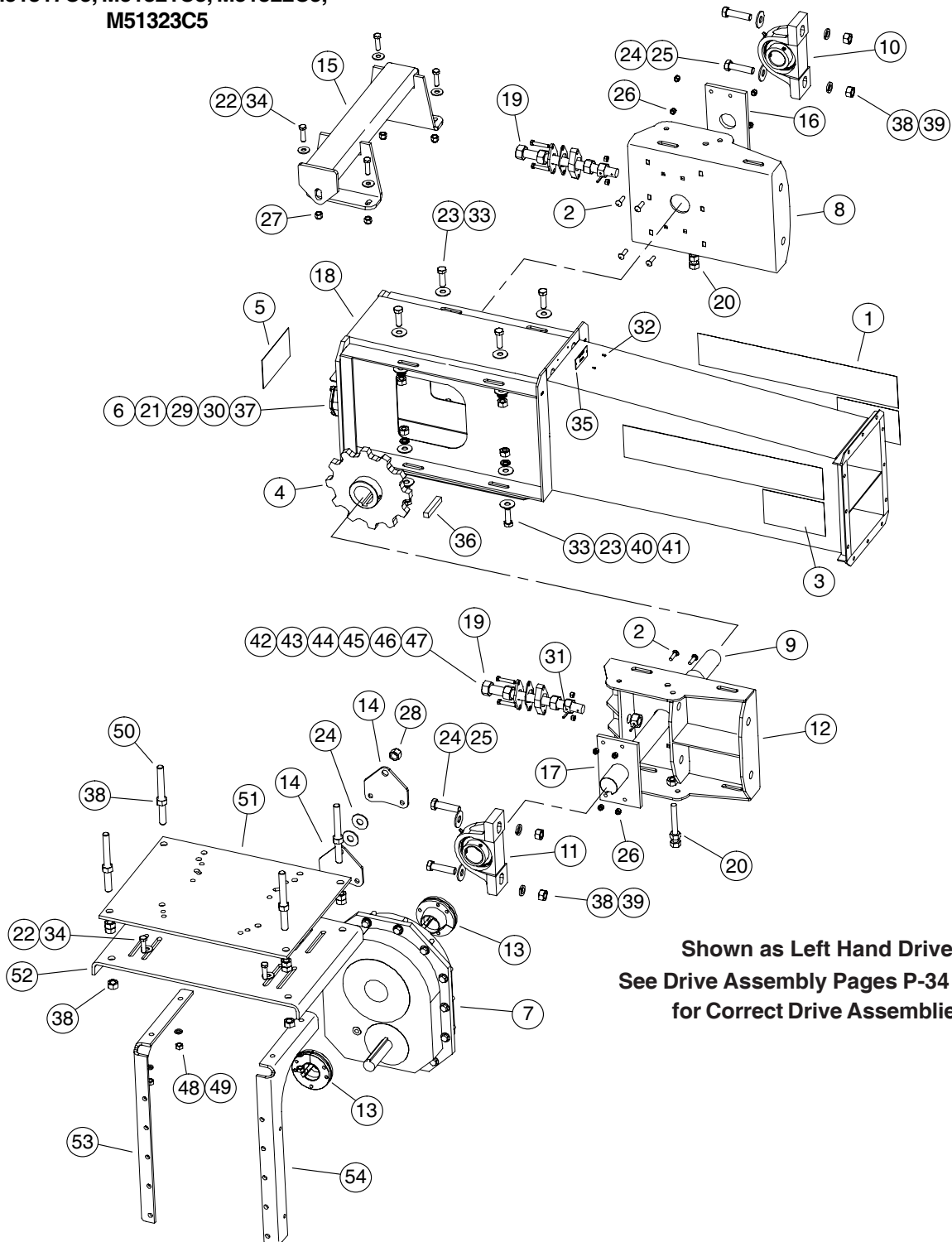

**Shown as Left Hand Drive  
See Drive Assembly Pages P-34 & P-35  
for Correct Drive Assemblies**

## HEAD SECTION, MODEL 50

**Head Assembly 1042966**  
**M50 Assembly f/ TA4207H15 Reducer**  
**f/ Drive Assemblies**  
**M51317C5, M51321C5, M51322C5,**  
**M51323C5**

**The Head Assembly is also available with**  
**AR and ARS Plating.**

Ref. No.	Part No.	Description	Ref. No.	Part No.	Description
1	1001125	Decal, Hutchinson (rectangle)	28	33140	Nut, 3/4"-10 Nylon Lock PLT
2	1002248	Bolt, 3/8"-16 x 1 1/4" Carriage G5 PLT	29	33142	Washer, 3/16" Lock PLT
3	1002301	Decal, Caution: General Operator	30	33149	Nut, 3/16" Non-Lock PLT
4	1005564	Sprocket, 81C 12T, 2 7/16" bore	31	33158	Roll Pin, 3/16" x 1 1/4" long
5	1012872	Decal, Danger: Do Not Operate...	32	33188	Rivet, 1/8" Drive
6	1017092	Bolt, 3/16" x 1 1/2" Stove G5	33	33244	Bolt, 5/8"-11 x 2" G5 PLT
7	1023249	Reducer, TA4207H15 f/ Torque Arm II	34	33247	Bolt, 1/2"-13 x 1 3/4" G5 PLT
8	1042930	Slide Weldment, 2 1/4" Brng	35	34687	Serial Plate, Hutchinson/Mayrath
9	1042876	Shaft, f/ Head w/ TA4207H15 Reducer	36	53060	Key, 5/8" sq x 3 3/4" long
10	1042885	Bearing, Pillow Block (2")	37	90040	Fastener, Quick Release
11	1042888	Bearing, Pillow Block (2 1/4")	38	D1152	Nut, 3/4"-10 Non-Lock PLT
12	1042930	Slide Weldment, 2 1/4" Brng	39	D1153	Washer, 3/4" Lock PLT
13	1042953	Kit, Bushing, f/ TA4207H15 Reducer	40	D1170	Nut, 5/8"-11 Non-Lock PLT
14	1042974	Plate, Torque Arm, f/ TA4207H15 Rdcr	41	D1171	Washer, 5/8" Lock PLT
15	1042998	Torque Arm Weldment	42	1043407	Plate, Spacer f/ 1" Nut Retainer
16	1043045	Seal, Shaft (2" UMHW)	43	1043435	Plate, Thin Spacer f/ 1" Nut Rtnr.
17	1043046	Seal, f/ 2 1/4" Shaft	44	1043408	Retainer Plate f/ 1" Nut
18	1043050	Head Housing Weldment	45	D1158	Nut, 1"-8 Non-Lock PLT
19	1043078	Adjustment Rod	46	1002199	Bolt, 3/8"-16 x 2" G5 PLT
20	1043183	Rod, Bearing Slide Adjustment	47	1004783	Nut, 3/8"-16 Side Depress PLT
21	33021	Washer, 3/16" Flat PLT	48	D1143	Washer, 1/2" Lock PLT
22	33025	Washer, 1/2" Flat PLT	49	D1169	Nut, 1/2"-13 Non-Lock PLT
23	33026	Washer, 5/8" Flat PLT	50	1039771	Rod, Radius Arm Tension
24	33027	Washer, 3/4" Flat PLT	51	1043475	Plate, Motor Mount f/ TA4207H15
25	33112	Bolt, 3/4"-10 x 3" G5 PLT	52	1043476	Support, Motor Mount
26	33136	Nut, 3/8"-16 Nylon Lock PLT	53	1043473	Angle, Motor Mount Support (left)
27	33138	Nut, 1/2"-13 Nylon Lock PLT	54	1043474	Angle, Motor Mount Support (right)

**See Drive Assembly Pages P-34 & P-35**  
**for Correct Drive Assemblies**

**Note: Parts Illustration is Shown for the Standard Left Hand Drive. For Right Hand Drive Units, some Components may be Reversed, Particularly Items, 8, 10, 11, 12, 16 & 17.**

**Note: If Item 17 (Shaft Seal) is Larger than Item 16 (Shaft Seal) the Larger Seal will be Located on the Reducer Side.**

# PARTS LIST

## HEAD SECTION, MODEL 85

Head Assembly 1044679  
M85 Assembly f/ TA0107L15 Reducer  
f/ Drive Assemblies  
M85321C6, M85329C6, M85337C6,  
M85345C6

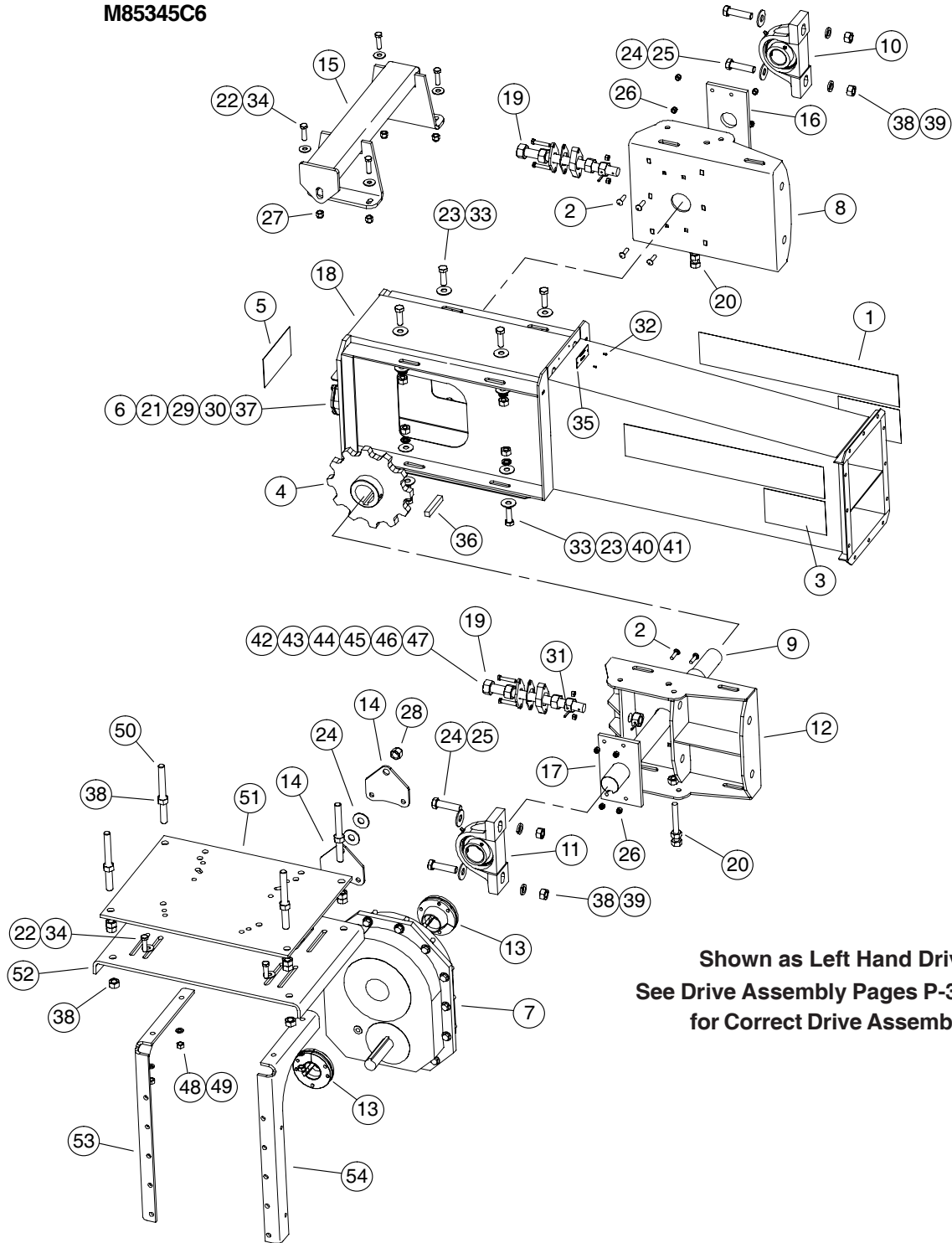

**Shown as Left Hand Drive  
See Drive Assembly Pages P-36 & P-37  
for Correct Drive Assemblies**

## HEAD SECTION, MODEL 85

### Head Assembly 1044679

#### M85 Assembly f/ TA0107L15 Reducer f/ Drive Assemblies

**M85321C6, M85329C6, M85337C6,  
M85345C6**

**The Head Assembly is also available with  
AR and ARS Plating.**

Ref. No.	Part No.	Description	Ref. No.	Part No.	Description
1	1001125	Decal, Hutchinson (rectangle)	28	33140	Nut, 3/4"-10 Nylon Lock PLT
2	1002248	Bolt, 3/8"-16 x 1 1/4" Carriage G5 PLT	29	33142	Washer, 3/16" Lock PLT
3	1002301	Decal, Caution: General Operator	30	33149	Nut, 3/16" Non-Lock PLT
4	420064	Sprocket, 81C 16T, 1 1/2" bore	31	33158	Roll Pin, 3/16" x 1 1/4" long
5	1012872	Decal, Danger: Do Not Operate...	32	33188	Rivet, 1/8" Drive
6	1017092	Bolt, 3/16" x 1 1/2" Stove G5	33	33244	Bolt, 5/8"-11 x 2" G5 PLT
7	1042850	Reducer, TA0107L15 f/ Torque Arm II	34	33247	Bolt, 1/2"-13 x 1 3/4" G5 PLT
8	1043009	Slide Weldment, 1 1/2" Brng	35	34687	Serial Plate, Hutchinson/Mayrath
9	1042871	Shaft, f/ Head w/ TA0107L15 Reducer	36	4073A1	Key, 3/8" sq x 3" long
10	1042884	Bearing, Pillow Block (1 1/2")	37	90040	Fastener, Quick Release
11	1042884	Bearing, Pillow Block (1 1/2")	38	D1152	Nut, 3/4"-10 Non-Lock PLT
12	1043009	Slide Weldment, 1 1/2" Brng	39	D1153	Washer, 3/4" Lock PLT
13	1042951	Kit, Bushing, f/ TA0107L15 Reducer	40	D1170	Nut, 5/8"-11 Non-Lock PLT
14	1042970	Plate, Torque Arm, f/ TA0107L15 Rdcr	41	D1171	Washer, 5/8" Lock PLT
15	1042999	Torque Arm Weldment	42	1043407	Plate, Spacer f/ 1" Nut Retainer
16	1043044	Seal, Shaft (1 1/2" UMHW)	43	1043435	Plate, Thin Spacer f/ 1" Nut Rtrnr.
17	1043044	Seal, f/ 1 1/2" Shaft	44	1043408	Retainer Plate f/ 1" Nut
18	1043023	Head Housing Weldment (24" opening)	45	D1158	Nut, 1"-8 Non-Lock PLT
(18)	1044625	Head Housing Weldment (30" opening)	46	1002199	Bolt, 3/8"-16 x 2" G5 PLT
19	1043078	Adjustment Rod	47	1004783	Nut, 3/8"-16 Side Depress PLT
20	1043183	Rod, Bearing Slide Adjustment	48	D1143	Washer, 1/2" Lock PLT
21	33021	Washer, 3/16" Flat PLT	49	D1169	Nut, 1/2"-13 Non-Lock PLT
22	33025	Washer, 1/2" Flat PLT	50	1039771	Rod, Radius Arm Tension
23	33026	Washer, 5/8" Flat PLT	51	1043507	Plate, Motor Mount f/ TA0107L15
24	33027	Washer, 3/4" Flat PLT	52	1043508	Support, Motor Mount
25	33112	Bolt, 3/4"-10 x 3" G5 PLT	53	1043488	Angle, Motor Mount Support (left)
26	33136	Nut, 3/8"-16 Nylon Lock PLT	54	1043489	Angle, Motor Mount Support (right)
27	33138	Nut, 1/2"-13 Nylon Lock PLT			

**See Drive Assembly Pages P-36 & P-37  
for Correct Drive Assemblies**

**Note: Parts Illustration is Shown for the Standard Left Hand Drive. For Right Hand Drive Units, some Components may be Reversed, Particularly Items, 8, 10, 11, 12, 16 & 17.**

**Note: If Item 17 (Shaft Seal) is Larger than Item 16 (Shaft Seal) the Larger Seal will be Located on the Reducer Side.**

**Note: On serial no's. 953499 and higher, the M85 head discharge opening is 30" (76.2 cm) long compared to the previous 24" (61.0 cm) length.**

# PARTS LIST

## **HEAD SECTION, MODEL 85**

**Head Assembly 1044680**  
**M85 Assembly f/ TA1107H15 Reducer**  
**f/ Drive Assemblies**  
**M85330C6, M85338C6, M85346C6,**  
**M85347C6, M85357C6**

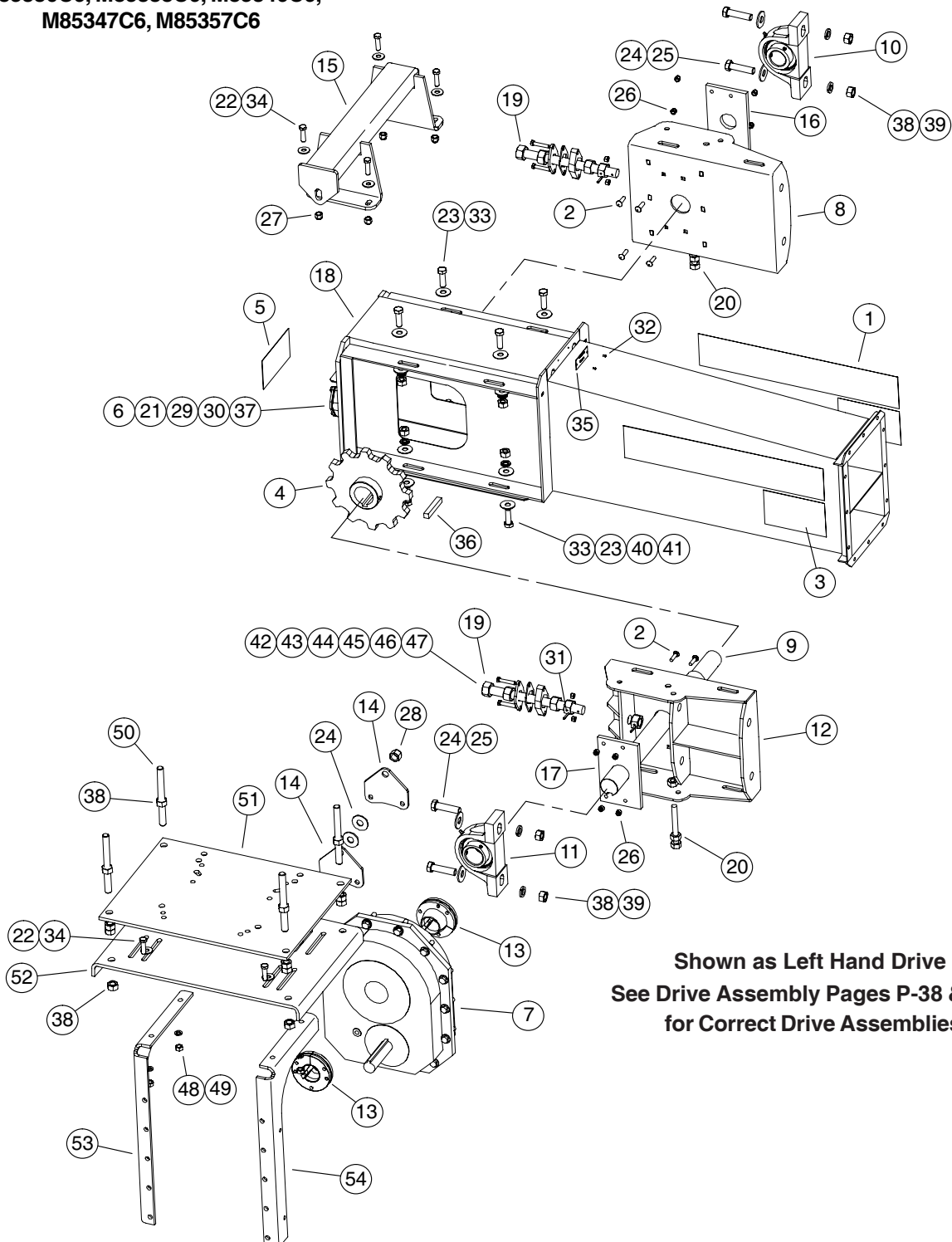

**Shown as Left Hand Drive**  
**See Drive Assembly Pages P-38 & P-39**  
**for Correct Drive Assemblies**

## **HEAD SECTION, MODEL 85**

**Head Assembly 1044680**  
**M85 Assembly f/ TA1107H15 Reducer**  
**f/ Drive Assemblies**  
**M85330C6, M85338C6, M85346C6,**  
**M85347C6, M85357C6**

**The Head Assembly is also available with**  
**AR and ARS Plating.**

Ref. No.	Part No.	Description	Ref. No.	Part No.	Description
1	1001125	Decal, Hutchinson (rectangle)	28	33140	Nut, 3/4"-10 Nylon Lock PLT
2	1002248	Bolt, 3/8"-16 x 1 1/4" Carriage G5 PLT	29	33142	Washer, 3/16" Lock PLT
3	1002301	Decal, Caution: General Operator	30	33149	Nut, 3/16" Non-Lock PLT
4	420092	Sprocket, 81C 16T, 2" bore	31	33158	Roll Pin, 3/16" x 1 1/4" long
5	1012872	Decal, Danger: Do Not Operate...	32	33188	Rivet, 1/8" Drive
6	1017092	Bolt, 3/16" x 1 1/2" Stove G5	33	33244	Bolt, 5/8"-11 x 2" G5 PLT
7	1042851	Reducer, TA1107H15 f/ Torque Arm II	34	33247	Bolt, 1/2"-13 x 1 3/4" G5 PLT
8	1043009	Slide Weldment, 1 1/2" Brng	35	34687	Serial Plate, Hutchinson/Mayrath
9	1042873	Shaft, f/ Head w/ TA1107H15 Reducer	36	4021L1	Key, 1/2" sq x 2 3/4" long
10	1042884	Bearing, Pillow Block (1 1/2")	37	90040	Fastener, Quick Release
11	1042884	Bearing, Pillow Block (1 1/2")	38	D1152	Nut, 3/4"-10 Non-Lock PLT
12	1043009	Slide Weldment, 1 1/2" Brng	39	D1153	Washer, 3/4" Lock PLT
13	1041602	Kit, Bushing, f/ TA1107H15 Reducer	40	D1170	Nut, 5/8"-11 Non-Lock PLT
14	1042971	Plate, Torque Arm, f/ TA1107H15 Rdcr	41	D1171	Washer, 5/8" Lock PLT
15	1043000	Torque Arm Weldment	42	1043407	Plate, Spacer f/ 1" Nut Retainer
16	1043044	Seal, Shaft (1 1/2" UMHW)	43	1043435	Plate, Thin Spacer f/ 1" Nut Rtrn.
17	1043044	Seal, f/ 1 1/2" Shaft	44	1043408	Retainer Plate f/ 1" Nut
18	1043023	Head Housing Weldment (24" opening)	45	D1158	Nut, 1"-8 Non-Lock PLT
(18)	1044625	Head Housing Weldment (30" opening)	46	1002199	Bolt, 3/8"-16 x 2" G5 PLT
19	1043078	Adjustment Rod	47	1004783	Nut, 3/8"-16 Side Depress PLT
20	1043183	Rod, Bearing Slide Adjustment	48	D1143	Washer, 1/2" Lock PLT
21	33021	Washer, 3/16" Flat PLT	49	D1169	Nut, 1/2"-13 Non-Lock PLT
22	33025	Washer, 1/2" Flat PLT	50	1039771	Rod, Radius Arm Tension
23	33026	Washer, 5/8" Flat PLT	51	1043509	Plate, Motor Mount f/ TA1107H15
24	33027	Washer, 3/4" Flat PLT	52	1043510	Support, Motor Mount
25	33112	Bolt, 3/4"-10 x 3" G5 PLT	53	1043490	Angle, Motor Mount Support (left)
26	33136	Nut, 3/8"-16 Nylon Lock PLT	54	1043491	Angle, Motor Mount Support (right)
27	33138	Nut, 1/2"-13 Nylon Lock PLT			

**See Drive Assembly Pages P-38 & P-39**  
**for Correct Drive Assemblies**

**Note: Parts Illustration is Shown for the Standard Left Hand Drive. For Right Hand Drive Units, some Components may be Reversed, Particularly Items, 8, 10, 11, 12, 16 & 17.**

**Note: If Item 17 (Shaft Seal) is Larger than Item 16 (Shaft Seal) the Larger Seal will be Located on the Reducer Side.**

**Note: On serial no's. 953499 and higher, the M85 head discharge opening is 30" (76.2 cm) long compared to the previous 24" (61.0 cm) length.**

# PARTS LIST

## HEAD SECTION, MODEL 85

Head Assembly 1044681

M85 Assembly f/ TA2115H15 Reducer  
f/ Drive Assemblies

M85322C6, M85323C6, M85331C6,  
M85332C6, M85339C6, M85340C6,  
M85348C6, M85361C6

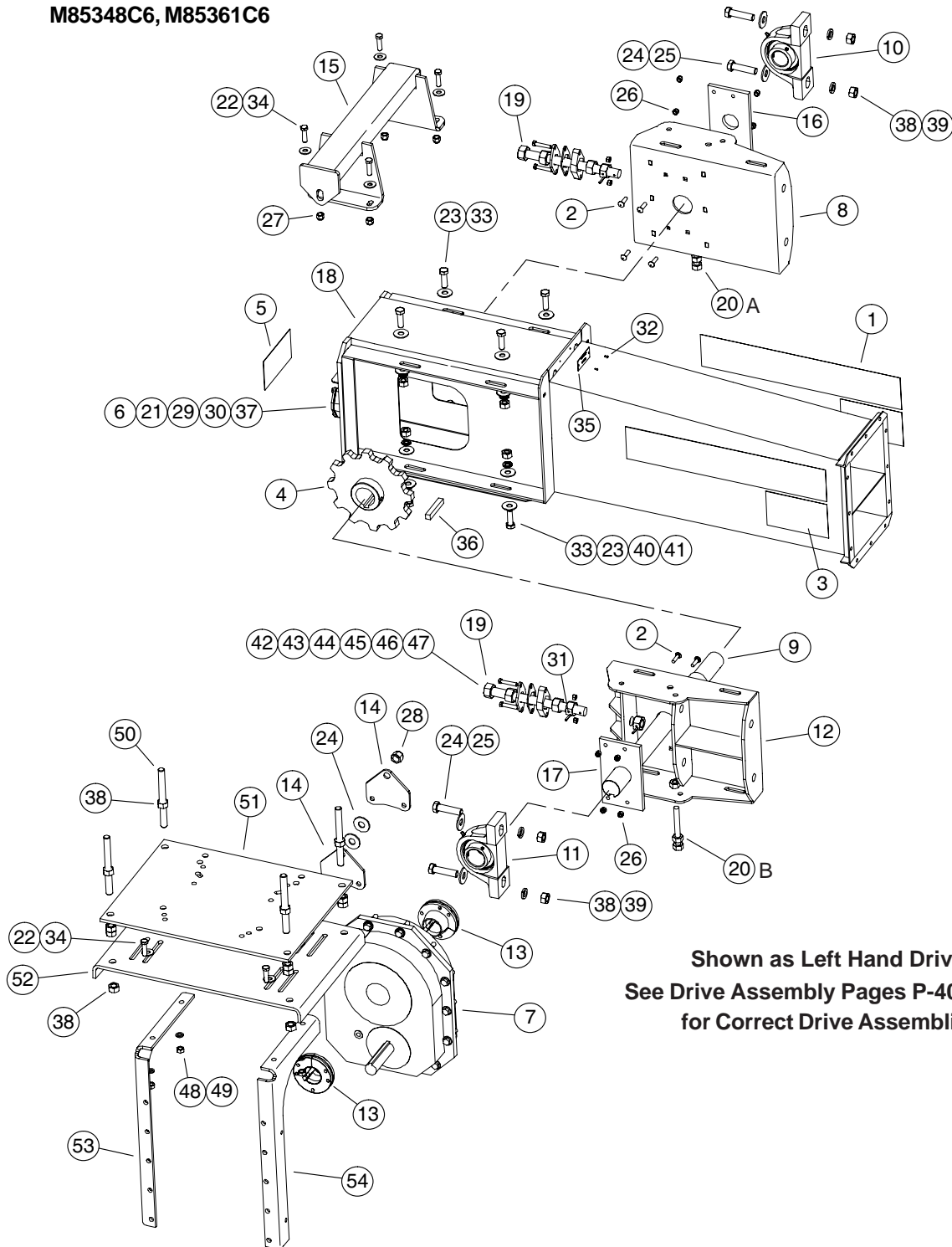

**Shown as Left Hand Drive  
See Drive Assembly Pages P-40 to P-42  
for Correct Drive Assemblies**

## HEAD SECTION, MODEL 85

**Head Assembly 1044681**  
**M85 Assembly f/ TA2115H15 Reducer**  
**f/ Drive Assemblies**  
**M85322C6, M85323C6, M85331C6,**  
**M85332C6, M85339C6, M85340C6,**  
**M85348C6, M85361C6**

**The Head Assembly is also available with**  
**AR and ARS Plating.**

Ref. No.	Part No.	Description	Ref. No.	Part No.	Description
1	1001125	Decal, Hutchinson (rectangle)	28	33140	Nut, 3/4"-10 Nylon Lock PLT
2	1002248	Bolt, 3/8"-16 x 1 1/4" Carriage G5 PLT	29	33142	Washer, 3/16" Lock PLT
3	1002301	Decal, Caution: General Operator	30	33149	Nut, 3/16" Non-Lock PLT
4	420065	Sprocket, 81C 16T, 2 7/16" bore	31	33158	Roll Pin, 3/16" x 1 1/4" long
5	1012872	Decal, Danger: Do Not Operate...	32	33188	Rivet, 1/8" Drive
6	1017092	Bolt, 3/16" x 1 1/2" Stove G5	33	33244	Bolt, 5/8"-11 x 2" G5 PLT
7	1042852	Reducer, TA2115H15 f/ Torque Arm II	34	33247	Bolt, 1/2"-13 x 1 3/4" G5 PLT
8	1043009	Slide Weldment, 1 1/2" Brng	35	34687	Serial Plate, Hutchinson/Mayrath
9	1042875	Shaft, f/ Head w/ TA2115H15 Reducer	36	53060	Key, 5/8" sq x 3 3/4" long
10	1042884	Bearing, Pillow Block (1 1/2")	37	90040	Fastener, Quick Release
11	1042885	Bearing, Pillow Block (2")	38	D1152	Nut, 3/4"-10 Non-Lock PLT
12	1042931	Slide Weldment, 2 1/4" Brng	39	D1153	Washer, 3/4" Lock PLT
13	1040864	Kit, Bushing, f/ TA2115H15 Reducer	40	D1170	Nut, 5/8"-11 Non-Lock PLT
14	1042972	Plate, Torque Arm, f/ TA2115H15 Rdcr	41	D1171	Washer, 5/8" Lock PLT
15	1043001	Torque Arm Weldment	42	1043407	Plate, Spacer f/ 1" Nut Retainer
16	1043044	Seal, Shaft (1 1/2" UMHW)	43	1043435	Plate, Thin Spacer f/ 1" Nut Rtrn.
17	1043045	Seal, f/ 2" Shaft	44	1043408	Retainer Plate f/ 1" Nut
18	1043023	Head Housing Weldment (24" opening)	45	D1158	Nut, 1"-8 Non-Lock PLT
(18)	1044625	Head Housing Weldment (24" opening)	46	1002199	Bolt, 3/8"-16 x 2" G5 PLT
19	1043078	Adjustment Rod	47	1004783	Nut, 3/8"-16 Side Depress PLT
20A	1043183	Rod, Bearing Slide Adjustment (5/8")	48	D1143	Washer, 1/2" Lock PLT
20B	1043181	Rod, Bearing Slide Adjustment (3/4")	49	D1169	Nut, 1/2"-13 Non-Lock PLT
21	33021	Washer, 3/16" Flat PLT	50	1039771	Rod, Radius Arm Tension
22	33025	Washer, 1/2" Flat PLT	51	1043511	Plate, Motor Mount f/ TA2115H15
23	33026	Washer, 5/8" Flat PLT	52	1043512	Support, Motor Mount
24	33027	Washer, 3/4" Flat PLT	53	1043492	Angle, Motor Mount Support (left)
25	33112	Bolt, 3/4"-10 x 3" G5 PLT	54	1043493	Angle, Motor Mount Support (right)
26	33136	Nut, 3/8"-16 Nylon Lock PLT			
27	33138	Nut, 1/2"-13 Nylon Lock PLT			

**See Drive Assembly Pages P-40 to P-42**  
**for Correct Drive Assemblies**

**Note: Parts Illustration is Shown for the Standard Left Hand Drive. For Right Hand Drive Units, some Components may be Reversed, Particularly Items, 8, 10, 11, 12, 16 & 17.**

**Note: If Item 17 (Shaft Seal) is Larger than Item 16 (Shaft Seal) the Larger Seal will be Located on the Reducer Side.**

**Note: On serial no's. 953499 and higher, the M85 head discharge opening is 30" (76.2 cm) long compared to the previous 24" (61.0 cm) length.**

# PARTS LIST

## **HEAD SECTION, MODEL 85**

Head Assembly 1044682

M85 Assembly f/ TA3203H15 Reducer  
f/ Drive Assemblies

M85324C6, M85333C6, M85341C6,  
M85349C6, M85350C6

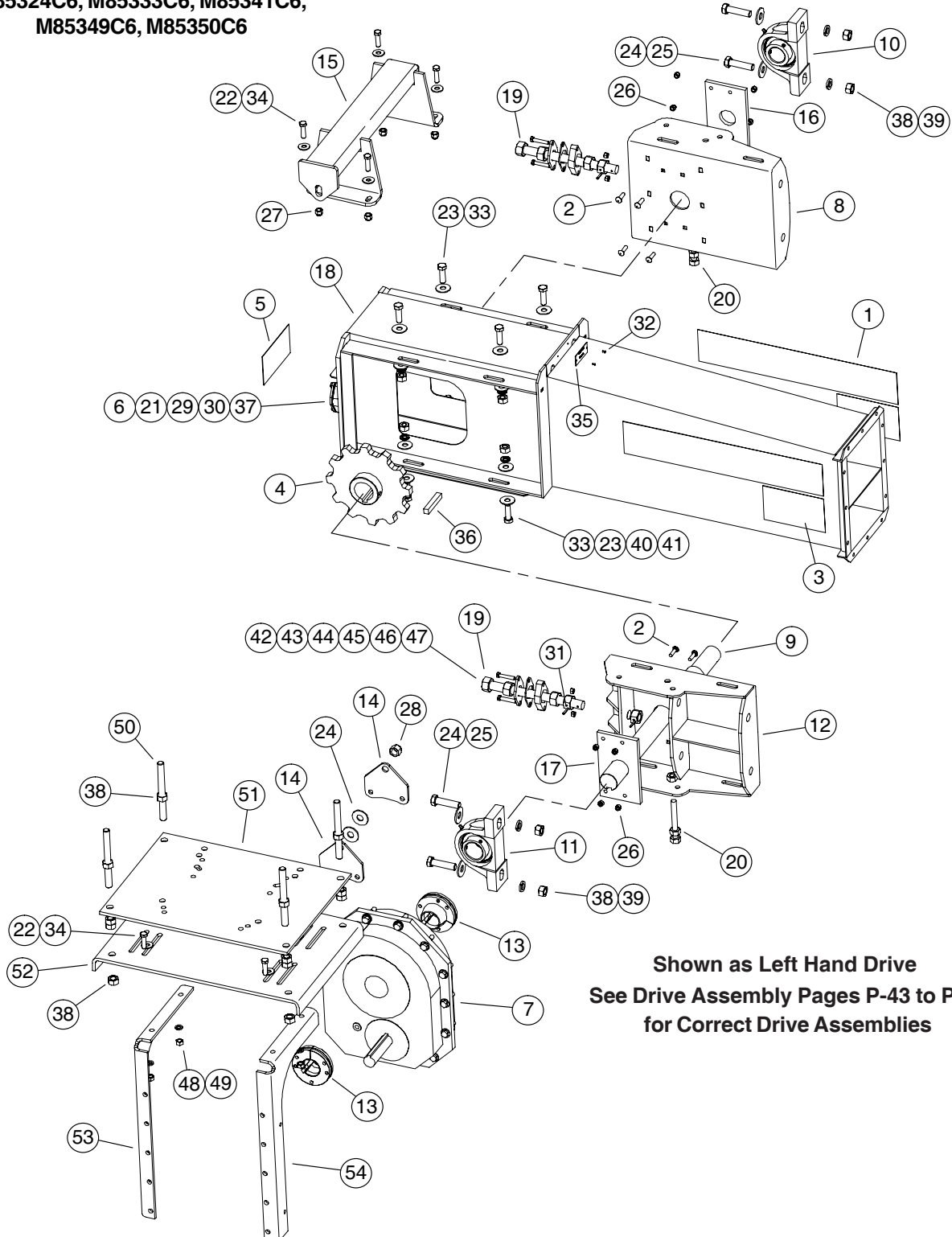

**Shown as Left Hand Drive  
See Drive Assembly Pages P-43 to P-44  
for Correct Drive Assemblies**

## HEAD SECTION, MODEL 85

**Head Assembly 1044682**  
**M85 Assembly f/ TA3203H15 Reducer**  
**f/ Drive Assemblies**  
**M85324C6, M85333C6, M85341C6,**  
**M85349C6, M85350C6**

**The Head Assembly is also available with**  
**AR and ARS Plating.**

Ref. No.	Part No.	Description	Ref. No.	Part No.	Description
1	1001125	Decal, Hutchinson (rectangle)	28	33140	Nut, 3/4"-10 Nylon Lock PLT
2	1002248	Bolt, 3/8"-16 x 1 1/4" Carriage G5 PLT	29	33142	Washer, 3/16" Lock PLT
3	1002301	Decal, Caution: General Operator	30	33149	Nut, 3/16" Non-Lock PLT
4	420065	Sprocket, 81C 16T, 2 7/16" bore	31	33158	Roll Pin, 3/16" x 1 1/4" long
5	1012872	Decal, Danger: Do Not Operate...	32	33188	Rivet, 1/8" Drive
6	1017092	Bolt, 3/16" x 1 1/2" Stove G5	33	33244	Bolt, 5/8"-11 x 2" G5 PLT
7	1036873	Reducer, TA3203H15 f/ Torque Arm II	34	33247	Bolt, 1/2"-13 x 1 3/4" G5 PLT
8	1042931	Slide Weldment, 2 1/4" Brng	35	34687	Serial Plate, Hutchinson/Mayrath
9	1042877	Shaft, f/ Head w/ TA3203H15 Reducer	36	53060	Key, 5/8" sq x 3 3/4" long
10	1042885	Bearing, Pillow Block (2")	37	90040	Fastener, Quick Release
11	1042888	Bearing, Pillow Block (2 1/4")	38	D1152	Nut, 3/4"-10 Non-Lock PLT
12	1042931	Slide Weldment, 2 1/4" Brng	39	D1153	Washer, 3/4" Lock PLT
13	1042952	Kit, Bushing, f/ TA3203H15 Reducer	40	D1170	Nut, 5/8"-11 Non-Lock PLT
14	1042973	Plate, Torque Arm, f/ TA3203H15 Rdcr	41	D1171	Washer, 5/8" Lock PLT
15	1043002	Torque Arm Weldment	42	1043407	Plate, Spacer f/ 1" Nut Retainer
16	1043045	Seal, Shaft (2" UMHW)	43	1043435	Plate, Thin Spacer f/ 1" Nut Rtnr.
17	1043046	Seal, f/ 2 1/4" Shaft	44	1043408	Retainer Plate f/ 1" Nut
18	1043023	Head Housing Weldment (24" opening)	45	D1158	Nut, 1"-8 Non-Lock PLT
(18)	1044625	Head Housing Weldment (30" opening)	46	1002199	Bolt, 3/8"-16 x 2" G5 PLT
19	1043078	Adjustment Rod	47	1004783	Nut, 3/8"-16 Side Depress PLT
20	1043181	Rod, Bearing Slide Adjustment	48	D1143	Washer, 1/2" Lock PLT
21	33021	Washer, 3/16" Flat PLT	49	D1169	Nut, 1/2"-13 Non-Lock PLT
22	33025	Washer, 1/2" Flat PLT	50	1039771	Rod, Radius Arm Tension
23	33026	Washer, 5/8" Flat PLT	51	1043513	Plate, Motor Mount f/ TA3203H15
24	33027	Washer, 3/4" Flat PLT	52	1043514	Support, Motor Mount
25	33112	Bolt, 3/4"-10 x 3" G5 PLT	53	1043494	Angle, Motor Mount Support (left)
26	33136	Nut, 3/8"-16 Nylon Lock PLT	54	1043495	Angle, Motor Mount Support (right)
27	33138	Nut, 1/2"-13 Nylon Lock PLT			

**See Drive Assembly Pages P-43 to P-44**  
**for Correct Drive Assemblies**

**Note: Parts Illustration is Shown for the Standard Left Hand Drive. For Right Hand Drive Units, some Components may be Reversed, Particularly Items, 8, 10, 11, 12, 16 & 17.**

**Note: If Item 17 (Shaft Seal) is Larger than Item 16 (Shaft Seal) the Larger Seal will be Located on the Reducer Side.**

**Note: On serial no's. 953499 and higher, the M85 head discharge opening is 30" (76.2 cm) long compared to the previous 24" (61.0 cm) length.**

# PARTS LIST

## ***HEAD SECTION, MODEL 85***

Head Assembly 1044683

M85 Assembly f/ TA4207H15 Reducer  
f/ Drive Assemblies

M85326C6, M85335C6, M85342C6,  
M85344C6, M85351C6,  
M85352C6, M85355C6, M85356C6,  
M85353C6

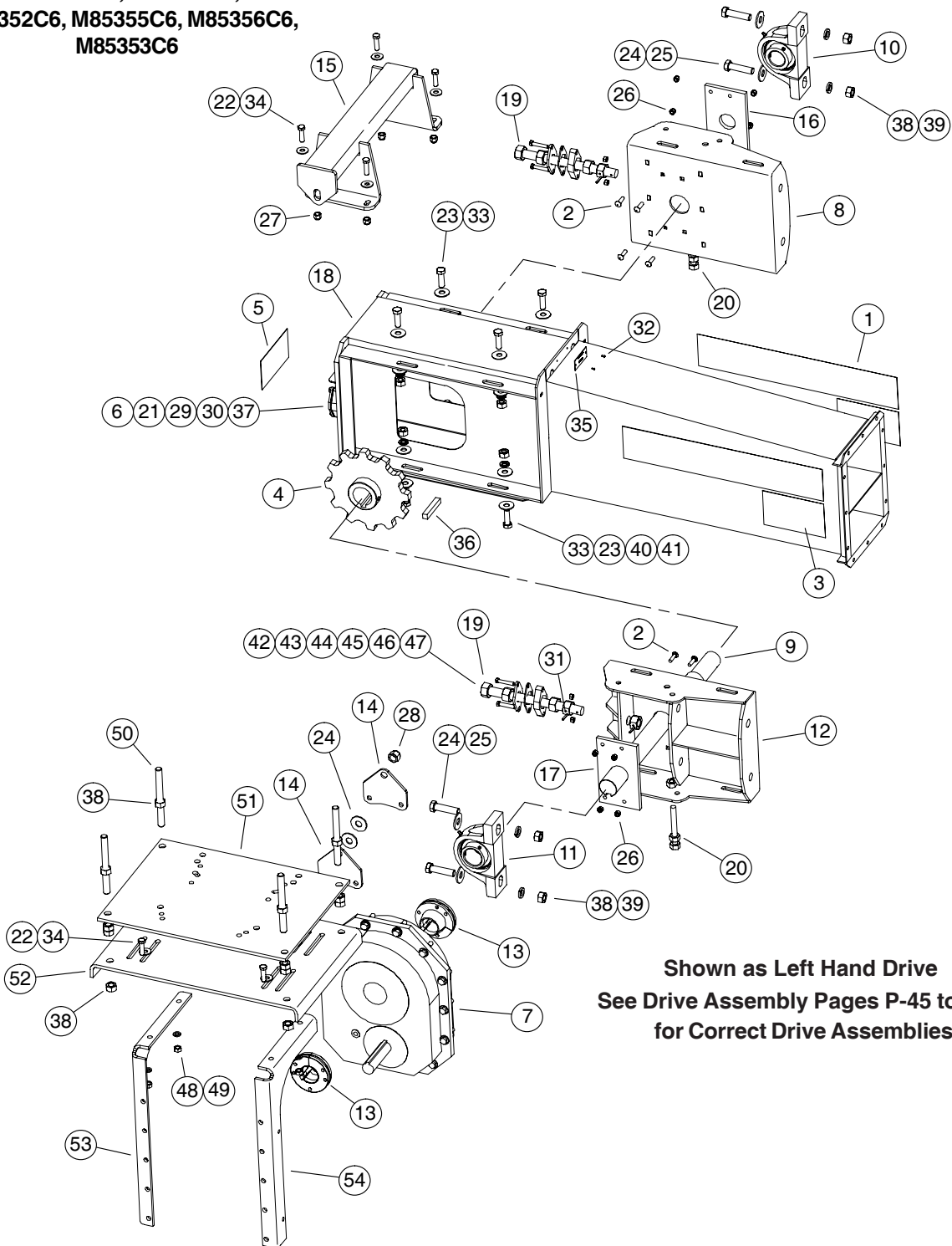

**Shown as Left Hand Drive  
See Drive Assembly Pages P-45 to P-47  
for Correct Drive Assemblies**

## **HEAD SECTION, MODEL 85**

**Head Assembly 1044683**  
**M85 Assembly f/ TA4207H15 Reducer**  
**f/ Drive Assemblies**  
**M85326C6, M85335C6, M85342C6,**  
**M85344C6, M85351C6,**  
**M85352C6, M85355C6, M85356C6,**  
**M85353C6**

**The Head Assembly is also available with**  
**AR and ARS Plating.**

Ref. No.	Part No.	Description	Ref. No.	Part No.	Description
1	1001125	Decal, Hutchinson (rectangle)	28	33140	Nut, 3/4"-10 Nylon Lock PLT
2	1002248	Bolt, 3/8"-16 x 1 1/4" Carriage G5 PLT	29	33142	Washer, 3/16" Lock PLT
3	1002301	Decal, Caution: General Operator	30	33149	Nut, 3/16" Non-Lock PLT
4	420066	Sprocket, 81C 16T, 2 15/16" bore	31	33158	Roll Pin, 3/16" x 1 1/4" long
5	1012872	Decal, Danger: Do Not Operate...	32	33188	Rivet, 1/8" Drive
6	1017092	Bolt, 3/16" x 1 1/2" Stove G5	33	33244	Bolt, 5/8"-11 x 2" G5 PLT
7	1023249	Reducer, TA4207H15 f/ Torque Arm II	34	33247	Bolt, 1/2"-13 x 1 3/4" G5 PLT
8	1042931	Slide Weldment, 2 1/4" Brng	35	34687	Serial Plate, Hutchinson/Mayrath
9	1042878	Shaft, f/ Head w/ TA4207H15 Reducer	36	553512	Key, 3/4" sq x 3 1/2" long
10	1042885	Bearing, Pillow Block (2")	37	90040	Fastener, Quick Release
11	1042886	Bearing, Pillow Block (2 1/2")	38	D1152	Nut, 3/4"-10 Non-Lock PLT
12	1043008	Slide Weldment, 2 1/2" Brng	39	D1153	Washer, 3/4" Lock PLT
13	1042954	Kit, Bushing, f/ TA4207H15 Reducer	40	D1170	Nut, 5/8"-11 Non-Lock PLT
14	1042974	Plate, Torque Arm, f/ TA4207H15 Rdcr	41	D1171	Washer, 5/8" Lock PLT
15	1043003	Torque Arm Weldment	42	1043407	Plate, Spacer f/ 1" Nut Retainer
16	1043045	Seal, Shaft (2" UMHW)	43	1043435	Plate, Thin Spacer f/ 1" Nut Rtnr.
17	1043047	Seal, f/ 2 1/2" Shaft	44	1043408	Retainer Plate f/ 1" Nut
18	1043023	Head Housing Weldment (24" opening)	45	D1158	Nut, 1"-8 Non-Lock PLT
(18)	1044625	Head Housing Weldment (30" opening)	46	1002199	Bolt, 3/8"-16 x 2" G5 PLT
19	1043078	Adjustment Rod	47	1004783	Nut, 3/8"-16 Side Depress PLT
20	1043183	Rod, Bearing Slide Adjustment	48	D1143	Washer, 1/2" Lock PLT
21	33021	Washer, 3/16" Flat PLT	49	D1169	Nut, 1/2"-13 Non-Lock PLT
22	33025	Washer, 1/2" Flat PLT	50	1039771	Rod, Radius Arm Tension
23	33026	Washer, 5/8" Flat PLT	51	1043475	Plate, Motor Mount f/ TA4207H15
24	33027	Washer, 3/4" Flat PLT	52	1043476	Support, Motor Mount
25	33112	Bolt, 3/4"-10 x 3" G5 PLT	53	1043473	Angle, Motor Mount Support (left)
26	33136	Nut, 3/8"-16 Nylon Lock PLT	54	1043474	Angle, Motor Mount Support (right)
27	33138	Nut, 1/2"-13 Nylon Lock PLT			

**See Drive Assembly Pages P-45 to P-47**  
**for Correct Drive Assemblies**

**Note: Parts Illustration is Shown for the Standard Left Hand Drive. For Right Hand Drive Units, some Components may be Reversed, Particularly Items, 8, 10, 11, 12, 16 & 17.**

**Note: If Item 17 (Shaft Seal) is Larger than Item 16 (Shaft Seal) the Larger Seal will be Located on the Reducer Side.**

**Note: On serial no's. 953499 and higher, the M85 head discharge opening is 30" (76.2 cm) long compared to the previous 24" (61.0 cm) length.**

# PARTS LIST

## HEAD SECTION, MODEL 85

Head Assembly 1044684  
M85 Assembly f/ TA5215H15 Reducer  
f/ Drive Assembly  
M85354C6, M85360C6

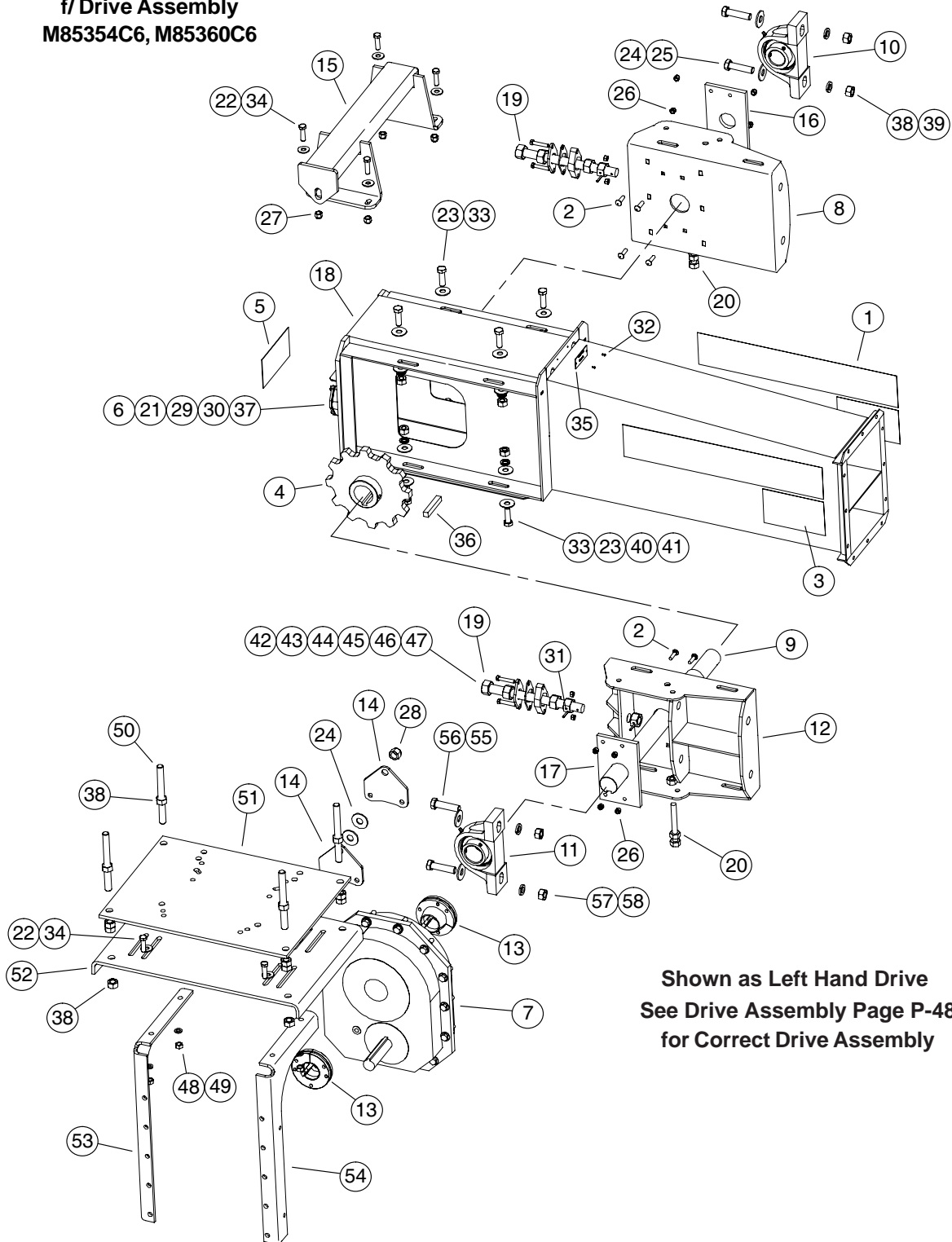

Shown as Left Hand Drive  
See Drive Assembly Page P-48  
for Correct Drive Assembly

## HEAD SECTION, MODEL 85

**Head Assembly 1044684  
M85 Assembly f/ TA5215H15 Reducer  
f/ Drive Assembly  
M85354C6, M85360C6**

**The Head Assembly is also available with  
AR and ARS Plating.**

Ref. No.	Part No.	Description	Ref. No.	Part No.	Description
1	1001125	Decal, Hutchinson (rectangle)	30	33149	Nut, 3/16" Non-Lock PLT
2	1002248	Bolt, 3/8"-16 x 1 1/4" Carriage G5 PLT	31	33158	Roll Pin, 3/16" x 1 1/4" long
3	1002301	Decal, Caution: General Operator	32	33188	Rivet, 1/8" Drive
4	420066	Sprocket, 81C 16T, 2 15/16" bore	33	33244	Bolt, 5/8"-11 x 2" G5 PLT
5	1012872	Decal, Danger: Do Not Operate...	34	33247	Bolt, 1/2"-13 x 1 3/4" G5 PLT
6	1017092	Bolt, 3/16" x 1 1/2" Stove G5	35	34687	Serial Plate, Hutchinson/Mayrath
7	1023780	Reducer, TA5215H15 f/ Torque Arm II	36	553512	Key, 3/4" sq x 3 1/2" long
8	1042931	Slide Weldment, 2 1/4" Brng	37	90040	Fastener, Quick Release
9	1042879	Shaft, f/ Head w/ TA5215H15 Reducer	38	D1152	Nut, 3/4"-10 Non-Lock PLT
10	1042885	Bearing, Pillow Block (2")	39	D1153	Washer, 3/4" Lock PLT
11	1042887	Bearing, Pillow Block (2 3/4")	40	D1170	Nut, 5/8"-11 Non-Lock PLT
12	1043013	Slide Weldment, 2 3/4" Brng	41	D1171	Washer, 5/8" Lock PLT
13	1042955	Kit, Bushing, f/ TA5215H15 Reducer	42	1043407	Plate, Spacer f/ 1" Nut Retainer
14	1042975	Plate, Torque Arm, f/ TA5215H15 Rdcr	43	1043435	Plate, Thin Spacer f/ 1" Nut Rtnr.
15	1043004	Torque Arm Weldment	44	1043408	Retainer Plate f/ 1" Nut
16	1043045	Seal, Shaft (2" UMHW)	45	D1158	Nut, 1"-8 Non-Lock PLT
17	1043048	Seal, f/ 2 3/4" Shaft	46	1002199	Bolt, 3/8"-16 x 2" G5 PLT
18	1043023	Head Housing Weldment (24" opening)	47	1004783	Nut, 3/8"-16 Side Depress PLT
(18)	1044625	Head Housing Weldment (30" opening)	48	D1143	Washer, 1/2" Lock PLT
19	1043078	Adjustment Rod	49	D1169	Nut, 1/2"-13 Non-Lock PLT
20	1043183	Rod, Bearing Slide Adjustment	50	1039771	Rod, Radius Arm Tension
21	33021	Washer, 3/16" Flat PLT	51	1043515	Plate, Motor Mount f/ TA5215H15
22	33025	Washer, 1/2" Flat PLT	52	1043516	Support, Motor Mount
23	33026	Washer, 5/8" Flat PLT	53	1043496	Angle, Motor Mount Support (left)
24	33027	Washer, 3/4" Flat PLT	54	1043497	Angle, Motor Mount Support (rght)
25	33112	Bolt, 3/4"-10 x 3" G5 PLT	55	33285	Washer, 7/8" Flat PLT
26	33136	Nut, 3/8"-16 Nylon Lock PLT	56	1017146	Bolt, 7/8"-9 x 3 1/2" G5 PLT
27	33138	Nut, 1/2"-13 Nylon Lock PLT	57	D1231	Washer, 7/8" Lock PLT
28	33140	Nut, 3/4"-10 Nylon Lock PLT	58	D1232	Nut, 7/8"-9 Non-Lock PLT
29	33142	Washer, 3/16" Lock PLT			

**See Drive Assembly Page P-48  
for Correct Drive Assembly**

**Note: Parts Illustration is Shown for the Standard Left Hand Drive. For Right Hand Drive Units, some Components may be Reversed, Particularly Items, 8, 10, 11, 12, 16 & 17.**

**Note: If Item 17 (Shaft Seal) is Larger than Item 16 (Shaft Seal) the Larger Seal will be Located on the Reducer Side.**

**Note: On serial no's. 953499 and higher, the M85 Head discharge opening is 30" (76.2 cm) long compared to the previous 24" (61.0 cm) length.**

# PARTS LIST

## **DRIVE ASSEMBLIES, MODEL 50**

### **Drive Assemblies**

**M50300C5, M50305C5, M50310C5,  
M50311C5, M50315C5,  
M50316C5**

**f/ Head Assembly 1042962**

**M50 Assembly w/ TA0107L15 Reducer**

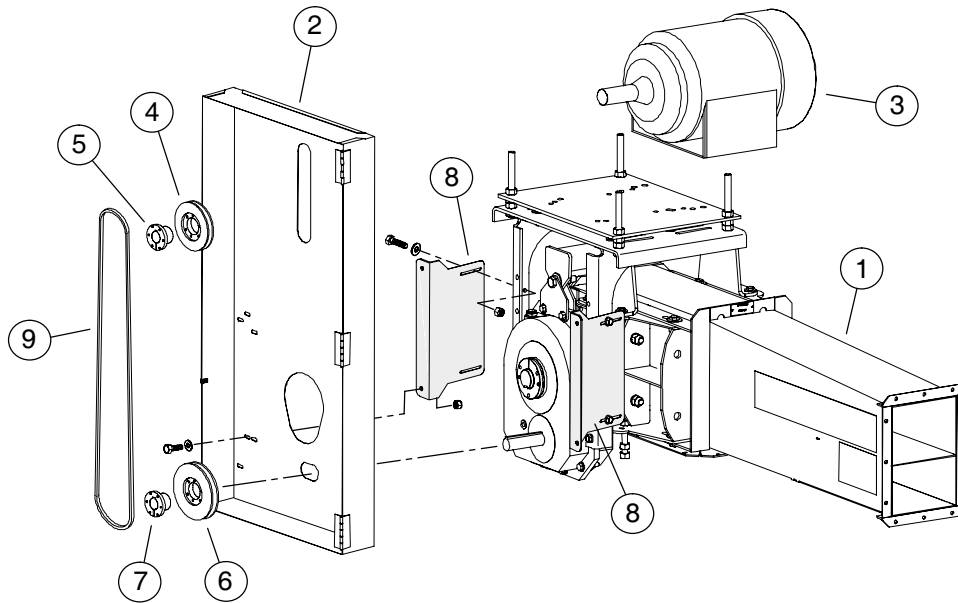

### **M50300C5 - 2500 BPH - 150 FPM - 58 RPM - 3 HP**

Item	Part No.	Description	Qty.
1	1043050	Wldmnt, M50 Mss tr Mvr Hd Hsng f/ Trq Arm II Drvs	1
2	1043083	Belt Grd Wldmnt Lrg f/ Mss Ter Mvr Hd Drv w/ Trq Arm II Red.	1
3	Motor Ref.	3 HP 3 Phs Motor	1
4	3236A1	Sheave - 4.2 - 1B Drive	1
5	3079A1	Bushing - SH 1 1/8" Drive	1
6	3260A1	Sheave, Driven QD 8.6" P.D. 1B	1
7	3047L1	Bushing, Driven QD SDS 1"	1
8	1043087	Bracket, Belt Guard f/ TA0107L15 Torque Arm II Motor Mount	2
9	40125(1)	Belt, B-68 (sheaves 24.75" center-to-center)	1

### **M50305C5 - 3300 BPH - 200 FPM - 77 RPM - 3 HP**

Item	Part No.	Description	Qty.
1	1043050	Wldmnt, M50 Mss tr Mvr Hd Hsng f/ Trq Arm II Drvs	1
2	1043083	Belt Grd Wldmnt Lrg f/ Mss Ter Mvr Hd Drv w/ Trq Arm II Red.	1
3	Motor Ref.	3 HP 3 Phs Motor	1
4	3236A1	Sheave - 4.2 - 1B Drive	1
5	3079A1	Bushing - SH 1 1/8" Drive	1
6	3259A1	Sheave, Driven QD 6.4" P.D. 1B	1
7	3047L1	Bushing, Driven QD SDS 1"	1
8	1043087	Bracket, Belt Guard f/ TA0107L15 Torque Arm II Motor Mount	2
9	40123(1)	Belt, B-64 (sheaves 24.5" center-to-center)	1

# PARTS LIST

Drive Assemblies M50300C5, M50305C5, M50310C5,  
M50311C5, M50315C5, M50316C5 (con't.)

## M50310C5 - 4150 BPH - 250 FPM - 97 RPM - 3 HP

Item	Part No.	Description	Qty.
1	1043050	Wldmnt, M50 Mss tr Mvr Hd Hsng f/ Trq Arm II Drvs	1
2	1043083	Belt Grd Wldmnt Lrg f/ Mss Ter Mvr Hd Drv w/ Trq Arm II Red.	1
3	Motor Ref.	3 HP 3 Phs Motor	1
4	3082A1	Sheave - 3.8 - 1B Drive	1
5	3079A1	Bushing - SH 1 1/8" Drive	1
6	3081A1	Sheave, Driven QD 4.6" P.D. 1B	1
7	3047L1	Bushing, Driven QD SDS 1"	1
8	1043087	Bracket, Belt Guard f/ TA0107L15 Torque Arm II Motor Mount	2
9	40121	Belt, B-60 (sheaves 24.3" center-to-center)	1

## M50311C5 - 4150 BPH - 250 FPM - 97 RPM - 5 HP

Item	Part No.	Description	Qty.
1	1043050	Wldmnt, M50 Mss tr Mvr Hd Hsng f/ Trq Arm II Drvs	1
2	1043083	Belt Grd Wldmnt Lrg f/ Mss Ter Mvr Hd Drv w/ Trq Arm II Red.	1
3	Motor Ref.	5 HP 3 Phs Motor	1
4	3081A1	Sheave - 4.6 - 1B Drive	1
5	3077A1	Bushing - SDS 1 1/8" Drive	1
6	3258A1	Sheave, Driven QD 5.6" P.D. 1B	1
7	3047L1	Bushing, Driven QD SDS 1"	1
8	1043087	Bracket, Belt Guard f/ TA0107L15 Torque Arm II Motor Mount	2
9	40123	Belt, B-64 (sheaves 24.9" center-to-center)	1

## M50315C5 - 5000 BPH - 300 FPM - 116 RPM - 3 HP

Item	Part No.	Description	Qty.
1	1043050	Wldmnt, M50 Mss tr Mvr Hd Hsng f/ Trq Arm II Drvs	1
2	1043083	Belt Grd Wldmnt Lrg f/ Mss Ter Mvr Hd Drv w/ Trq Arm II Red.	1
3	Motor Ref.	3 HP 3 Phs Motor	1
4	3082A1	Sheave - 3.8 - 1B Drive	1
5	3079A1	Bushing - SH 1 1/8" Drive	1
6	3082A1	Sheave, Driven QD 3.8" P.D. 1B	1
7	3304A1	Bushing, Driven QD SH 1"	1
8	1043087	Bracket, Belt Guard f/ TA0107L15 Torque Arm II Motor Mount	2
9	40121	Belt, B-60 (sheaves 24.9" center-to-center)	1

## M50316C5 - 5000 BPH - 300 FPM - 116 RPM - 5 HP

Item	Part No.	Description	Qty.
1	1043050	Wldmnt, M50 Mss tr Mvr Hd Hsng f/ Trq Arm II Drvs	1
2	1043083	Belt Grd Wldmnt Lrg f/ Mss Ter Mvr Hd Drv w/ Trq Arm II Red.	1
3	Motor Ref.	5 HP 3 Phs Motor	1
4	3081A1	Sheave - 4.6 - 1B Drive	1
5	3077A1	Bushing - SDS 1 1/8" Drive	1
6	3081A1	Sheave, Driven QD 4.6" P.D. 1B	1
7	3047L1	Bushing, Driven QD SDS 1"	1
8	1043087	Bracket, Belt Guard f/ TA0107L15 Torque Arm II Motor Mount	2
9	40122	Belt, B-62 (sheaves 24.7" center-to-center)	1

# PARTS LIST

## **DRIVE ASSEMBLIES, MODEL 50**

### **Drive Assemblies**

**M50301C5, M50306C5, M50307C5,  
M50312C5, M50317C5,  
M50318C5**

**f/ Head Assembly 1042963**

**M50 Assembly w/ TA1107H15 Reducer**

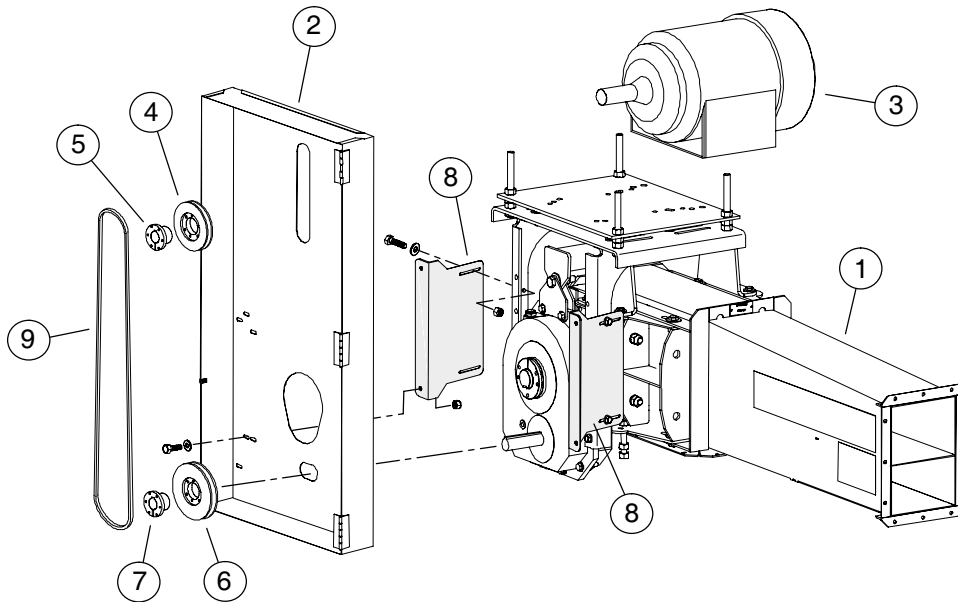

### **M50301C5 - 2500 BPH - 150 FPM - 58 RPM - 5 HP**

Item	Part No.	Description	Qty.
1	1043050	Wldmnt, M50 Mss tr Mvr Hd Hsng f/ Trq Arm II Drvs	1
2	1043083	Belt Grd Wldmnt Lrg f/ Mss Ter Mvr Hd Drv w/ Trq Arm II Red.	1
3	Motor Ref.	5 HP 3 Phs Motor	1
4	3236A1	Sheave - 4.2 - 1B Drive	1
5	3079A1	Bushing - SH 1 1/8" Drive	1
6	3260A1	Sheave, Driven QD 8.6" P.D. 1B	1
7	3047L1	Bushing, Driven QD SDS 1"	1
8	1043088	Bracket, Belt Guard f/ TA1107H15 Torque Arm II Motor Mount	2
9	40126(1)	Belt, B-71 (sheaves 26.25" center-to-center)	1

### **M50306C5 - 3300 BPH - 200 FPM - 77 RPM - 5 HP**

Item	Part No.	Description	Qty.
1	1043050	Wldmnt, M50 Mss tr Mvr Hd Hsng f/ Trq Arm II Drvs	1
2	1043083	Belt Grd Wldmnt Lrg f/ Mss Ter Mvr Hd Drv w/ Trq Arm II Red.	1
3	Motor Ref.	5 HP 3 Phs Motor	1
4	3236A1	Sheave - 4.2 - 1B Drive	1
5	3079A1	Bushing - SH 1 1/8" Drive	1
6	3259A1	Sheave, Driven QD 6.4" P.D. 1B	1
7	3047L1	Bushing, Driven QD SDS 1"	1
8	1043088	Bracket, Belt Guard f/ TA1107H15 Torque Arm II Motor Mount	2
9	40125(1)	Belt, B-68 (sheaves 26.5" center-to-center)	1

# PARTS LIST

Drive Assemblies M50301C5, M50306C5, M50307C5,  
M50312C5, M50317C5, M50318C5 (con't.)

## M50307C5 - 3300 BPH - 200 FPM - 77 RPM - 7.5 HP

Item	Part No.	Description	Qty.
1	1043050	Wldmnt, M50 Mss tr Mvr Hd Hsng f/ Trq Arm II Drvs	1
2	1043083	Belt Grd Wldmnt Lrg f/ Mss Ter Mvr Hd Drv w/ Trq Arm II Red.	1
3	Motor Ref.	7.5 HP 3 Phs Motor	1
4	3258A1	Sheave - 5.6 - 1B Drive	1
5	3087A1	Bushing - SDS 1 3/8" Drive	1
6	3260A1	Sheave, Driven QD 8.6" P.D. 1B	1
7	3047L1	Bushing, Driven QD SDS 1"	1
8	1043088	Bracket, Belt Guard f/ TA1107H15 Torque Arm II Motor Mount	2
9	1009129	Belt, B-73 (sheaves 26.2" center-to-center)	1

## M50312C5 - 4150 BPH - 250 FPM - 97 RPM - 7.5 HP

Item	Part No.	Description	Qty.
1	1043050	Wldmnt, M50 Mss tr Mvr Hd Hsng f/ Trq Arm II Drvs	1
2	1043083	Belt Grd Wldmnt Lrg f/ Mss Ter Mvr Hd Drv w/ Trq Arm II Red.	1
3	Motor Ref.	7.5 HP 3 Phs Motor	1
4	3258A1	Sheave - 5.6 - 1B Drive	1
5	3087A1	Bushing - SDS 1 3/8" Drive	1
6	3310A1	Sheave, Driven QD 6.8" P.D. 1B	1
7	3047L1	Bushing, Driven QD SDS 1"	1
8	1043088	Bracket, Belt Guard f/ TA1107H15 Torque Arm II Motor Mount	2
9	1009128(1)	Belt, B-70 (sheaves 26.2" center-to-center)	1

## M50317C5 - 5000 BPH - 300 FPM - 116 RPM - 7.5 HP

Item	Part No.	Description	Qty.
1	1043050	Wldmnt, M50 Mss tr Mvr Hd Hsng f/ Trq Arm II Drvs	1
2	1043083	Belt Grd Wldmnt Lrg f/ Mss Ter Mvr Hd Drv w/ Trq Arm II Red.	1
3	Motor Ref.	7.5 HP 3 Phs Motor	1
4	3258A1	Sheave - 5.6 - 1B Drive	1
5	3087A1	Bushing - SDS 1 3/8" Drive	1
6	3258A1	Sheave, Driven QD 5.6" P.D. 1B	1
7	3047L1	Bushing, Driven QD SDS 1"	1
8	1043088	Bracket, Belt Guard f/ TA1107H15 Torque Arm II Motor Mount	2
9	40125(1)	Belt, B-68 (sheaves 26.1" center-to-center)	1

## M50318C5 - 5000 BPH - 300 FPM - 116 RPM - 10 HP

Item	Part No.	Description	Qty.
1	1043050	Wldmnt, M50 Mss tr Mvr Hd Hsng f/ Trq Arm II Drvs	1
2	1043083	Belt Grd Wldmnt Lrg f/ Mss Ter Mvr Hd Drv w/ Trq Arm II Red.	1
3	Motor Ref.	10 HP 3 Phs Motor	1
4	3083A1	Sheave - 4.6 - 2B Drive	1
5	3087A1	Bushing - SDS 1 3/8" Drive	1
6	3083A1	Sheave, Driven QD 4.6" P.D. 2B	1
7	3047L1	Bushing, Driven QD SDS 1"	1
8	1043088	Bracket, Belt Guard f/ TA1107H15 Torque Arm II Motor Mount	2
9	40124(2)	Belt, B-66 (sheaves 26.7" center-to-center)	2

# PARTS LIST

## ***DRIVE ASSEMBLIES, MODEL 50***

### **Drive Assemblies**

**M50302C5, M50308C5, M50313C5,**

**M50314C5, M50319C5**

**f/ Head Assembly 1042964**

**M50 Assembly w/ TA2115H15 Reducer**

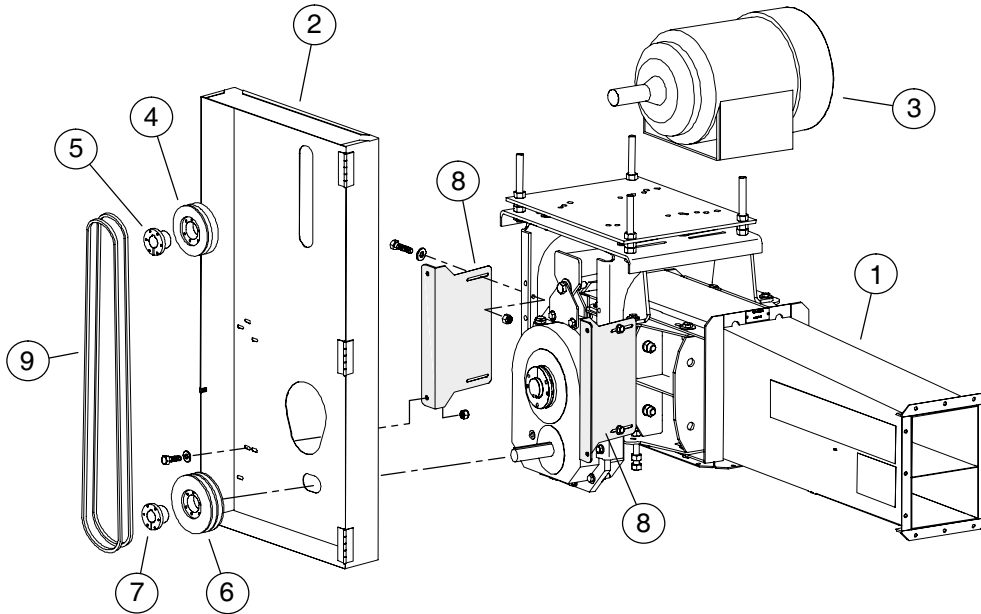

### **M50302C5 - 2500 BPH - 150 FPM - 58 RPM - 7.5 HP**

Item	Part No.	Description	Qty.
1	1043050	Wldmnt, M50 Mss tr Mvr Hd Hsng f/ Trq Arm II Drvs	1
2	1043083	Belt Grd Wldmnt Lrg f/ Mss Ter Mvr Hd Drv w/ Trq Arm II Red.	1
3	Motor Ref.	7.5 HP 3 Phs Motor	1
4	3232A1	Sheave - 3.8 - 2B Drive	1
5	3086A1	Bushing - SH 1 3/8" Drive	1
6	3235A1	Sheave, Driven QD 7.4" P.D. 2B	1
7	3188A1	Bushing, Driven QD SK 1 1/8"	1
8	1043089	Bracket, Belt Guard f/ TA2115H15 Torque Arm II Motor Mount	2
9	1009129(2)	Belt, B-73 (sheaves 28.5" center-to-center)	2

### **M50308C5 - 3300 BPH - 200 FPM - 77 RPM - 10 HP**

Item	Part No.	Description	Qty.
1	1043050	Wldmnt, M50 Mss tr Mvr Hd Hsng f/ Trq Arm II Drvs	1
2	1043083	Belt Grd Wldmnt Lrg f/ Mss Ter Mvr Hd Drv w/ Trq Arm II Red.	1
3	Motor Ref.	10 HP 3 Phs Motor	1
4	3259A1	Sheave - 6.4 - 1B Drive	1
5	3087A1	Bushing - SDS 1 3/8" Drive	1
6	3074A1	Sheave, Driven QD 9.4" P.D. 1B	1
7	3077A1	Bushing, Driven QD SDS 1 1/8"	1
8	1043089	Bracket, Belt Guard f/ TA2115H15 Torque Arm II Motor Mount	2
9	40340(1)	Belt, B-81 (sheaves 29.0" center-to-center)	1

# PARTS LIST

Drive Assemblies M50302C5, M50308C5, M50313C5,  
M50314C5, M50319C5 (con't.)

## M50313C5 - 4150 BPH - 250 FPM - 97 RPM - 10 HP

Item	Part No.	Description	Qty.
1	1043050	Wldmnt, M50 Mss tr Mvr Hd Hsng f/ Trq Arm II Drvs	1
2	1043083	Belt Grd Wldmnt Lrg f/ Mss Ter Mvr Hd Drv w/ Trq Arm II Red.	1
3	Motor Ref.	10 HP 3 Phs Motor	1
4	3083A1	Sheave - 4.6 - 2B Drive	1
5	3087A1	Bushing - SDS 1 3/8" Drive	1
6	3263A1	Sheave, Driven QD 5.4" P.D. 2B	1
7	3077A1	Bushing, Driven QD SDS 1 1/8"	1
8	1043089	Bracket, Belt Guard f/ TA2115H15 Torque Arm II Motor Mount	2
9	40126(2)	Belt, B-71 (sheaves 28.5" center-to-center)	2

## M50314C5 - 4150 BPH - 250 FPM - 97 RPM - 15 HP

Item	Part No.	Description	Qty.
1	1043050	Wldmnt, M50 Mss tr Mvr Hd Hsng f/ Trq Arm II Drvs	1
2	1043083	Belt Grd Wldmnt Lrg f/ Mss Ter Mvr Hd Drv w/ Trq Arm II Red.	1
3	Motor Ref.	15 HP 3 Phs Motor	1
4	3263A1	Sheave - 5.4 - 2B Drive	1
5	3183A1	Bushing - SDS 1 5/8" Drive	1
6	1026409	Sheave, Driven QD 6.2" P.D. 2B	1
7	3077A1	Bushing, Driven QD SDS 1 1/8"	1
8	1043089	Bracket, Belt Guard f/ TA2115H15 Torque Arm II Motor Mount	2
9	40127(2)	Belt, B-75 (sheaves 29.3" center-to-center)	2

## M50319C5 - 5000 BPH - 300 FPM - 116 RPM - 15 HP

Item	Part No.	Description	Qty.
1	1043050	Wldmnt, M50 Mss tr Mvr Hd Hsng f/ Trq Arm II Drvs	1
2	1043083	Belt Grd Wldmnt Lrg f/ Mss Ter Mvr Hd Drv w/ Trq Arm II Red.	1
3	Motor Ref.	15 HP 3 Phs Motor	1
4	3264A1	Sheave - 5.6 - 2B Drive	1
5	3183A1	Bushing - SDS 1 5/8" Drive	1
6	3264A1	Sheave, Driven QD 5.6" P.D. 2B	1
7	3077A1	Bushing, Driven QD SDS 1 1/8"	1
8	1043089	Bracket, Belt Guard f/ TA2115H15 Torque Arm II Motor Mount	2
9	1009129(2)	Belt, B-73 (sheaves 28.6" center-to-center)	2

# PARTS LIST

## ***DRIVE ASSEMBLIES, MODEL 50***

**Drive Assemblies**  
**M50303C5, M51305C5, M50309C5,**  
**M51311C5, M51316C5**  
**f/ Head Assembly 1042965**  
**M50 Assembly w/ TA3203H15 Reducer**

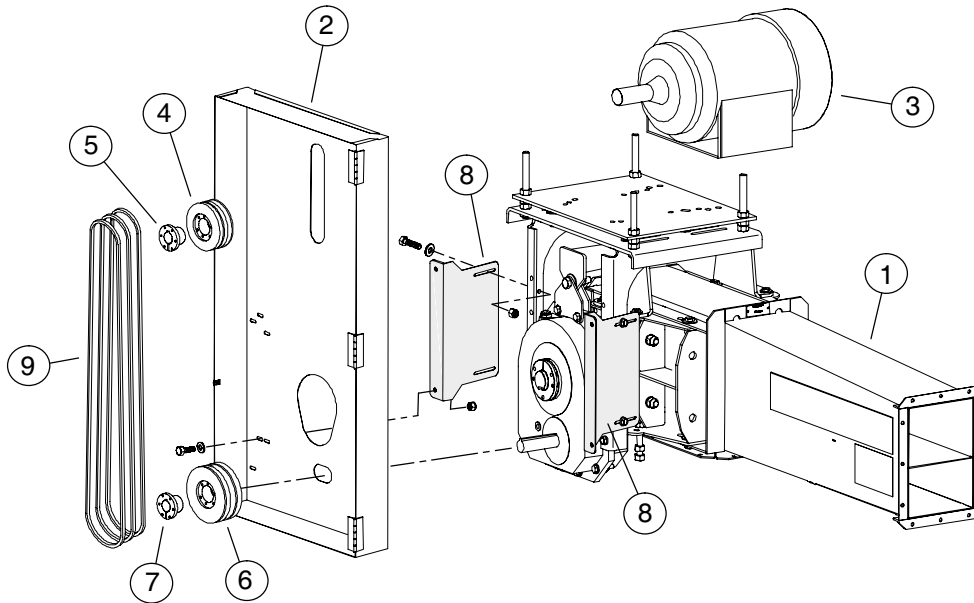

**M50303C5 - 2500 BPH - 150 FPM - 58 RPM - 10 HP**

Item	Part No.	Description	Qty.
1	1043050	Wldmnt, M50 Mss tr Mvr Hd Hsng f/ Trq Arm II Drvs	1
2	1043079	Belt Grd Wldmnt Lrg f/ Mss Ter Mvr Hd Drv w/ Trq Arm II Red.	1
3	Motor Ref.	10 HP 3 Phs Motor	1
4	1024515	Sheave - 4.2 - 2B Drive	1
5	3086A1	Bushing - SH 1 3/8" Drive	1
6	3090A1	Sheave, Driven QD 8.6" P.D. 2B	1
7	3190A1	Bushing, Driven QD SK 1 3/8"	1
8	1043090	Bracket, Belt Guard f/ TA3203H15 Torque Arm II Motor Mount	2
9	40340(2)	Belt, B-81 (sheaves 31.2" center-to-center)	2

**M51305C5 - 2500 BPH - 150 FPM - 58 RPM - 15 HP**

Item	Part No.	Description	Qty.
1	1043050	Wldmnt, M50 Mss tr Mvr Hd Hsng f/ Trq Arm II Drvs	1
2	1043079	Belt Grd Wldmnt Lrg f/ Mss Ter Mvr Hd Drv w/ Trq Arm II Red.	1
3	Motor Ref.	15 HP 3 Phs Motor	1
4	1024516	Sheave - 4.2 - 3B Drive	1
5	40018	Bushing - SH 1 5/8" Drive	1
6	3270A1	Sheave, Driven QD 8.6" P.D. 3B	1
7	3190A1	Bushing, Driven QD SK 1 3/8"	1
8	1043090	Bracket, Belt Guard f/ TA3203H15 Torque Arm II Motor Mount	2
9	40340(3)	Belt, B-81 (sheaves 31.2" center-to-center)	3

# PARTS LIST

**Drive Assemblies M50303C5, M51305C5, M50309C5,  
M51311C5, M51316C5 (con't.)**

**M50309C5 - 3300 BPH - 200 FPM - 77 RPM - 15 HP**

Item	Part No.	Description	Qty.
1	1043050	Wldmnt, M50 Mss tr Mvr Hd Hsng f/ Trq Arm II Drvs	1
2	1043079	Belt Grd Wldmnt Lrg f/ Mss Ter Mvr Hd Drv w/ Trq Arm II Red.	1
3	Motor Ref.	15 HP 3 Phs Motor	1
4	3264A1	Sheave - 5.6 - 2B Drive	1
5	3183A1	Bushing - SDS 1 5/8" Drive	1
6	3090A1	Sheave, Driven QD 8.6" P.D. 2B	1
7	3190A1	Bushing, Driven QD SK 1 3/8"	1
8	1043090	Bracket, Belt Guard f/ TA3203H15 Torque Arm II Motor Mount	2
9	1023084(2)	Belt, B-84 (sheaves 31.7" center-to-center)	2

**M51311C5 - 3300 BPH - 200 FPM - 77 RPM - 20 HP**

Item	Part No.	Description	Qty.
1	1043050	Wldmnt, M50 Mss tr Mvr Hd Hsng f/ Trq Arm II Drvs	1
2	1043079	Belt Grd Wldmnt Lrg f/ Mss Ter Mvr Hd Drv w/ Trq Arm II Red.	1
3	Motor Ref.	20 HP 3 Phs Motor	1
4	3267A1	Sheave - 5.6 - 3B Drive	1
5	3089A1	Bushing - SD 1 5/8" Drive	1
6	3270A1	Sheave, Driven QD 8.6" P.D. 3B	1
7	3190A1	Bushing, Driven QD SK 1 3/8"	1
8	1043090	Bracket, Belt Guard f/ TA3203H15 Torque Arm II Motor Mount	2
9	1023084(3)	Belt, B-84 (sheaves 31.7" center-to-center)	3

**M51316C5 - 4150 BPH - 250 FPM - 97 RPM - 20 HP**

Item	Part No.	Description	Qty.
1	1043050	Wldmnt, M50 Mss tr Mvr Hd Hsng f/ Trq Arm II Drvs	1
2	1043079	Belt Grd Wldmnt Lrg f/ Mss Ter Mvr Hd Drv w/ Trq Arm II Red.	1
3	Motor Ref.	20 HP 3 Phs Motor	1
4	3276A1	Sheave - 5.4 - 3B Drive	1
5	3089A1	Bushing - SD 1 5/8" Drive	1
6	3268A1	Sheave, Driven QD 6.4" P.D. 3B	1
7	3088A1	Bushing, Driven QD SD 1 3/8"	1
8	1043090	Bracket, Belt Guard f/ TA3203H15 Torque Arm II Motor Mount	2
9	40128(3)	Belt, B-78 (sheaves 30.6" center-to-center)	3

# PARTS LIST

## **DRIVE ASSEMBLIES, MODEL 50**

### **Drive Assemblies**

**M51317C5, M51321C5, M51322C5,  
M51323C5**

**f/ Head Assembly 1042966**

**M50 Assembly w/ TA4207H15 Reducer**

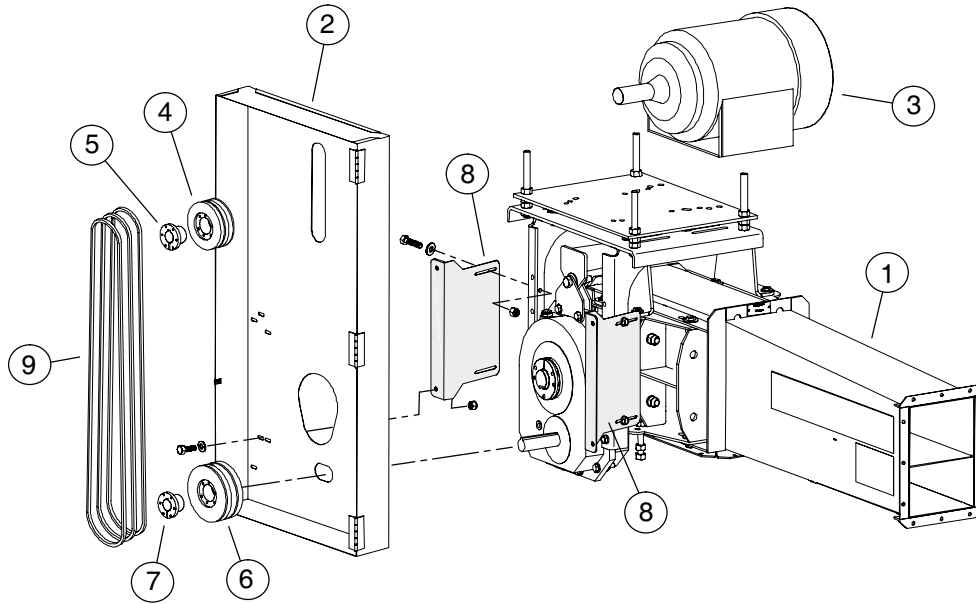

### **M51317C5 - 4150 BPH - 250 FPM - 97 RPM - 25 HP**

Item	Part No.	Description	Qty.
1	1043050	Wldmnt, M50 Mss tr Mvr Hd Hsng f/ Trq Arm II Drvs	1
2	1043079	Belt Grd Wldmnt Lrg f/ Mss Ter Mvr Hd Drv w/ Trq Arm II Red.	1
3	Motor Ref.	25 HP 3 Phs Motor	1
4	3267A1	Sheave - 5.6 - 3B QD Drive	1
5	3280A1	Bushing - SD 1 7/8" Drive	1
6	3269A1	Sheave, Driven 6.8" 3B	1
7	3278A1	Bushing, Driven QD SD 1 7/16"	1
8	1043091	Bracket, Belt Guard f/ TA4207H15 Torque Arm II Motor Mount	2
9	1016262(3)	Belt, B-93 (sheaves 37.7" center-to-center)	3

# PARTS LIST

Drive Assemblies M51317C5, M51321C5,  
M51322C5, M51323C5 (con't.)

## M51321C5 - 5000 BPH - 300 FPM - 116 RPM - 20 HP

Item	Part No.	Description	Qty.
1	1043050	Wldmnt, M50 Mss tr Mvr Hd Hsng f/ Trq Arm II Drvs	1
2	1043079	Belt Grd Wldmnt Lrg f/ Mss Ter Mvr Hd Drv w/ Trq Arm II Red.	1
3	Motor Ref.	20 HP 3 Phs Motor	1
4	3267A1	Sheave - 5.6 - 3B QD Drive	1
5	3089A1	Bushing - SD 1 5/8" Drive	1
6	3267A1	Sheave, Driven 5.6" QD 3B	1
7	3278A1	Bushing, Driven QD SD 1 7/16"	1
8	1043091	Bracket, Belt Guard f/ TA4207H15 Torque Arm II Motor Mount	2
9	40130(3)	Belt, B-88 (sheaves 36.1" center-to-center)	3

## M51322C5 - 5000 BPH - 300 FPM - 116 RPM - 25 HP

Item	Part No.	Description	Qty.
1	1043050	Wldmnt, M50 Mss tr Mvr Hd Hsng f/ Trq Arm II Drvs	1
2	1043079	Belt Grd Wldmnt Lrg f/ Mss Ter Mvr Hd Drv w/ Trq Arm II Red.	1
3	Motor Ref.	25 HP 3 Phs Motor	1
4	3242A1	Sheave - 6.0 - 3B QD Drive	1
5	3280A1	Bushing - SD 1 7/8" Drive	1
6	3242A1	Sheave, Driven 6.0" P.D. QD 3B	1
7	3278A1	Bushing, Driven QD SD 1 7/16"	1
8	1043091	Bracket, Belt Guard f/ TA4207H15 Torque Arm II Motor Mount	2
9	40131(3)	Belt, B-90 (sheaves 36.5" center-to-center)	3

## M51323C5 - 5000 BPH - 300 FPM - 116 RPM - 30 HP

Item	Part No.	Description	Qty.
1	1043050	Wldmnt, M50 Mss tr Mvr Hd Hsng f/ Trq Arm II Drvs	1
2	1043079	Belt Grd Wldmnt Lrg f/ Mss Ter Mvr Hd Drv w/ Trq Arm II Red.	1
3	Motor Ref.	30 HP 3 Phs Motor	1
4	3269A1	Sheave - 6.8 - 3B QD Drive	1
5	3280A1	Bushing - SD 1 7/8" Drive	1
6	3269A1	Sheave, Driven 6.8" P.D. QD 3B	1
7	3278A1	Bushing, Driven QD SD 1 7/16"	1
8	1043091	Bracket, Belt Guard f/ TA4207H15 Torque Arm II Motor Mount	2
9	1016262(3)	Belt, B-93 (sheaves 36.7" center-to-center)	3

# PARTS LIST

## **DRIVE ASSEMBLIES, MODEL 85**

### **Drive Assemblies**

**M85321C6, M85329C6, M85337C6,  
M85345C6**

**f/ Head Assembly 1044679**

**M85 Assembly w/ TA0107L15 Reducer**

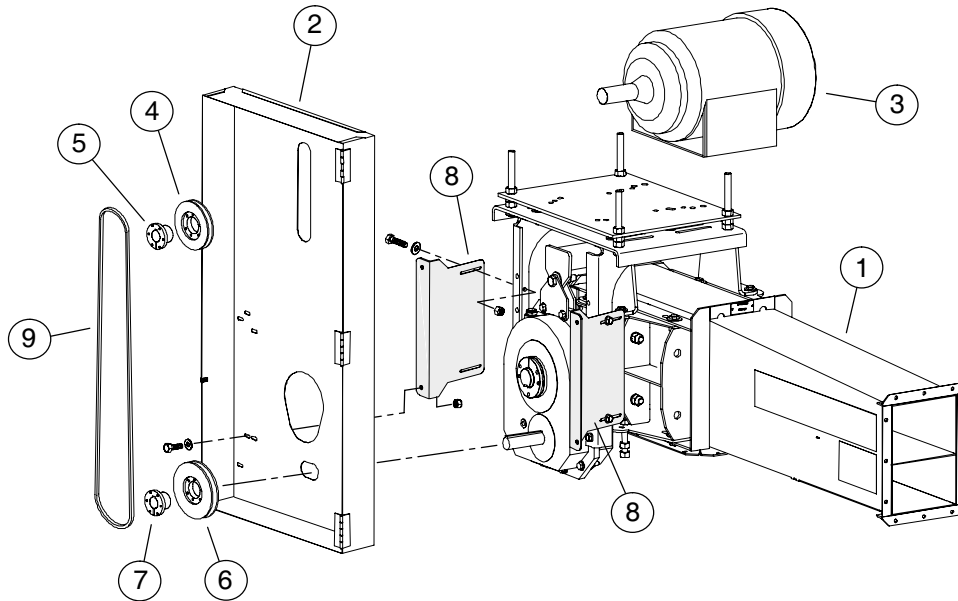

### **M85321C6 - 4000 BPH - 150 FPM - 43 RPM - 3 HP**

Item	Part No.	Description	Qty.
1	1044625	Wldmnt, M85 Mss tr Mvr Hd Hsng f/ Trq Arm II Drvs (30" opening)	1
2	1043083	Belt Grd Wldmnt Lrg f/ Mss Ter Mvr Hd Drv w/ Trq Arm II Red.	1
3	Motor Ref.	3 HP 3 Phs Motor	1
4	3236A1	Sheave - 4.2 - 1B Drive	1
5	3079A1	Bushing - SH 1 1/8" Drive	1
6	3307A1	Sheave, Driven QD 11.0" P.D. 1B	1
7	3047A1	Bushing, Driven QD SDS 1"	1
8	1043087	Bracket, Belt Guard f/ TA0107L15 Torque Arm II Motor Mount	2
9	1009129(1)	Belt, B-73 (sheaves 25.25" center-to-center)	1

# PARTS LIST

**Drive Assemblies M85321C6, M85329C6,  
M85337C6, M85345C6 (con't.)**

**M85329C6 - 5500 BPH - 200 FPM - 57 RPM - 3 HP**

Item	Part No.	Description	Qty.
1	1044625	Wldmnt, M85 Mss tr Mvr Hd Hsng f/ Trq Arm II Drvs (30" opening)	1
2	1043083	Belt Grd Wldmnt Lrg f/ Mss Ter Mvr Hd Drv w/ Trq Arm II Red.	1
3	Motor Ref.	3 HP 3 Phs Motor	1
4	3236A1	Sheave - 4.2 - 1B Drive	1
5	3079A1	Bushing - SH 1 1/8" Drive	1
6	3260A1	Sheave, Driven QD 8.6" P.D. 1B	1
7	3047L1	Bushing, Driven QD SDS 1"	1
8	1043087	Bracket, Belt Guard f/ TA0107L15 Torque Arm II Motor Mount	2
9	40125(1)	Belt, B-68 (sheaves 24.75" center-to-center)	1

**M85337C6 - 7000 BPH - 250 FPM - 72 RPM - 3 HP**

Item	Part No.	Description	Qty.
1	1044625	Wldmnt, M85 Mss tr Mvr Hd Hsng f/ Trq Arm II Drvs (30" opening)	1
2	1043083	Belt Grd Wldmnt Lrg f/ Mss Ter Mvr Hd Drv w/ Trq Arm II Red.	1
3	Motor Ref.	3 HP 3 Phs Motor	1
4	3236A1	Sheave - 4.2 - 1B Drive	1
5	3079A1	Bushing - SH 1 1/8" Drive	1
6	3310A1	Sheave, Driven QD 6.8" P.D. 1B	1
7	3047L1	Bushing, Driven QD SDS 1"	1
8	1043087	Bracket, Belt Guard f/ TA0107L15 Torque Arm II Motor Mount	2
9	40124(1)	Belt, B-66 (sheaves 25.25" center-to-center)	1

**M85345C6 - 8500 BPH - 300 FPM - 86 RPM - 3 HP**

Item	Part No.	Description	Qty.
1	1044625	Wldmnt, M85 Mss tr Mvr Hd Hsng f/ Trq Arm II Drvs (30" opening)	1
2	1043083	Belt Grd Wldmnt Lrg f/ Mss Ter Mvr Hd Drv w/ Trq Arm II Red.	1
3	Motor Ref.	3 HP 3 Phs Motor	1
4	3236A1	Sheave - 4.2 - 1B Drive	1
5	3079A1	Bushing - SH 1 1/8" Drive	1
6	3258A1	Sheave, Driven QD 5.6" P.D. 1B	1
7	3047L1	Bushing, Driven QD SDS 1"	1
8	1043087	Bracket, Belt Guard f/ TA0107L15 Torque Arm II Motor Mount	2
9	40123(1)	Belt, B-64 (sheaves 25.25" center-to-center)	1

# PARTS LIST

## ***DRIVE ASSEMBLIES, MODEL 85***

### **Drive Assemblies**

**M85330C6, M85338C6, M85346C6,**

**M85347C6, M85357C6**

**f/ Head Assembly 1044680**

**M85 Assembly w/ TA1107H15 Reducer**

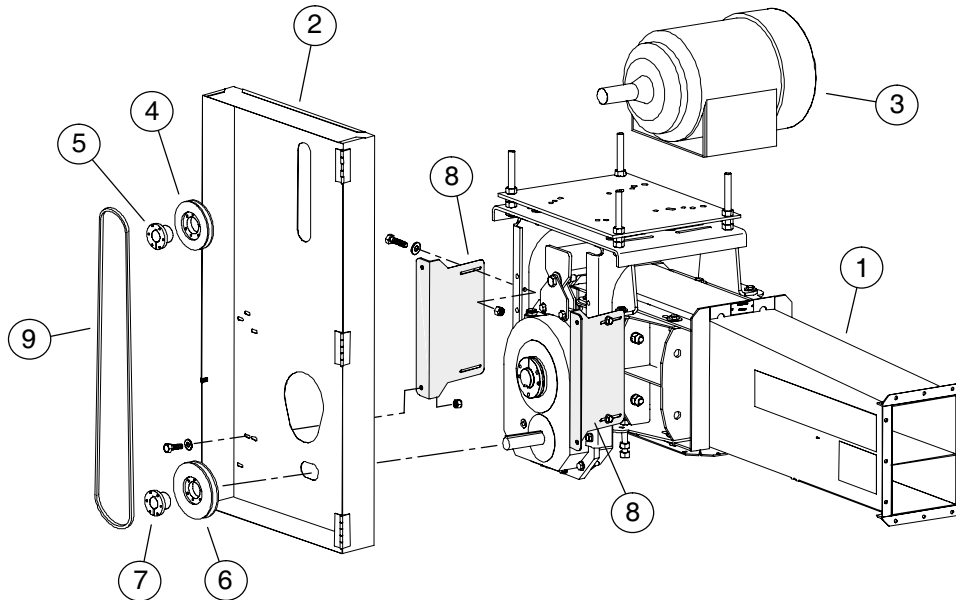

### **M85330C6 - 5500 BPH - 200 FPM - 57 RPM - 5 HP**

Item	Part No.	Description	Qty.
1	1044625	Wldmnt, M85 Mss tr Mvr Hd Hsng f/ Trq Arm II Drvs (30" opening)	1
2	1043083	Belt Grd Wldmnt Lrg f/ Mss Ter Mvr Hd Drv w/ Trq Arm II Red.	1
3	Motor Ref.	5 HP 3 Phs Motor	1
4	3236A1	Sheave - 4.2 - 1B Drive	1
5	3079A1	Bushing - SH 1 1/8" Drive	1
6	3260A1	Sheave, Driven QD 8.6" P.D. 1B	1
7	3047L1	Bushing, Driven QD SDS 1"	1
8	1043088	Bracket, Belt Guard f/ TA1107H15 Torque Arm II Motor Mount	2
9	1009128(1)	Belt, B-70 (sheaves 25.75" center-to-center)	1

### **M85338C6 - 7000 BPH - 250 FPM - 72 RPM - 5 HP**

Item	Part No.	Description	Qty.
1	1044625	Wldmnt, M85 Mss tr Mvr Hd Hsng f/ Trq Arm II Drvs (30" opening)	1
2	1043083	Belt Grd Wldmnt Lrg f/ Mss Ter Mvr Hd Drv w/ Trq Arm II Red.	1
3	Motor Ref.	5 HP 3 Phs Motor	1
4	3236A1	Sheave - 4.2 - 1B Drive	1
5	3079A1	Bushing - SH 1 1/8" Drive	1
6	3310A1	Sheave, Driven QD 6.8" P.D. 1B	1
7	3047L1	Bushing, Driven QD SDS 1"	1
8	1043088	Bracket, Belt Guard f/ TA1107H15 Torque Arm II Motor Mount	2
9	40125(1)	Belt, B-68 (sheaves 26.5" center-to-center)	1

# PARTS LIST

Drive Assemblies M85330C6, M85338C6,  
M85346C6, M85347C6, M85357C6 (con't.)

## M85346C6 - 8500 BPH - 300 FPM - 86 RPM - 5 HP

Item	Part No.	Description	Qty.
1	1044625	Wldmnt, M85 Mss tr Mvr Hd Hsng f/ Trq Arm II Drvs (30" opening)	1
2	1043083	Belt Grd Wldmnt Lrg f/ Mss Ter Mvr Hd Drv w/ Trq Arm II Red.	1
3	Motor Ref.	5 HP 3 Phs Motor	1
4	3081A1	Sheave - 4.6 - 1B Drive	1
5	3077A1	Bushing - SDS 1 1/8" Drive	1
6	1026408	Sheave, Driven QD 6.2" P.D. 1B	1
7	3047L1	Bushing, Driven QD SDS 1"	1
8	1043088	Bracket, Belt Guard f/ TA1107H15 Torque Arm II Motor Mount	2
9	40125(1)	Belt, B-68 (sheaves 26.5" center-to-center)	1

## M85347C6 - 8500 BPH - 300 FPM - 86 RPM - 7.5 HP

Item	Part No.	Description	Qty.
1	1044625	Wldmnt, M85 Mss tr Mvr Hd Hsng f/ Trq Arm II Drvs (30" opening)	1
2	1043083	Belt Grd Wldmnt Lrg f/ Mss Ter Mvr Hd Drv w/ Trq Arm II Red.	1
3	Motor Ref.	7.5 HP 3 Phs Motor	1
4	3083A1	Sheave - 4.6 - 2B Drive	1
5	3087A1	Bushing - SDS 1 3/8" Drive	1
6	1026409	Sheave, Driven QD 6.2" P.D. 2B	1
7	3047L1	Bushing, Driven QD SDS 1"	1
8	1043088	Bracket, Belt Guard f/ TA1107H15 Torque Arm II Motor Mount	2
9	40125(2)	Belt, B-68 (sheaves 26.5" center-to-center)	2

## M85357C6 - 10,000 BPH - 400 FPM - 115 RPM - 10 HP

Item	Part No.	Description	Qty.
1	1044625	Wldmnt, M85 Mss tr Mvr Hd Hsng f/ Trq Arm II Drvs (30" opening)	1
2	1043083	Belt Grd Wldmnt Lrg f/ Mss Ter Mvr Hd Drv w/ Trq Arm II Red.	1
3	Motor Ref.	10 HP 3 Phs Motor	1
4	3259A1	Sheave - 6.4 - 1B Drive	1
5	3087A1	Bushing - SDS 1 3/8" Drive	1
6	3310A1	Sheave, Driven QD 6.8" P.D. 1B	1
7	3047L1	Bushing, Driven QD SDS 1"	1
8	1043088	Bracket, Belt Guard f/ TA1107H15 Torque Arm II Motor Mount	2
9	40126(1)	Belt, B-71 (sheaves 26" center-to-center)	1

# PARTS LIST

## DRIVE ASSEMBLIES, MODEL 85

### Drive Assemblies

M85322C6, M85323C6, M85331C6,  
M85332C6, M85339C6, M85340C6,  
M85348C6, M85361C6

f/ Head Assembly 1044681

M85 Assembly w/ TA2115H15 Reducer

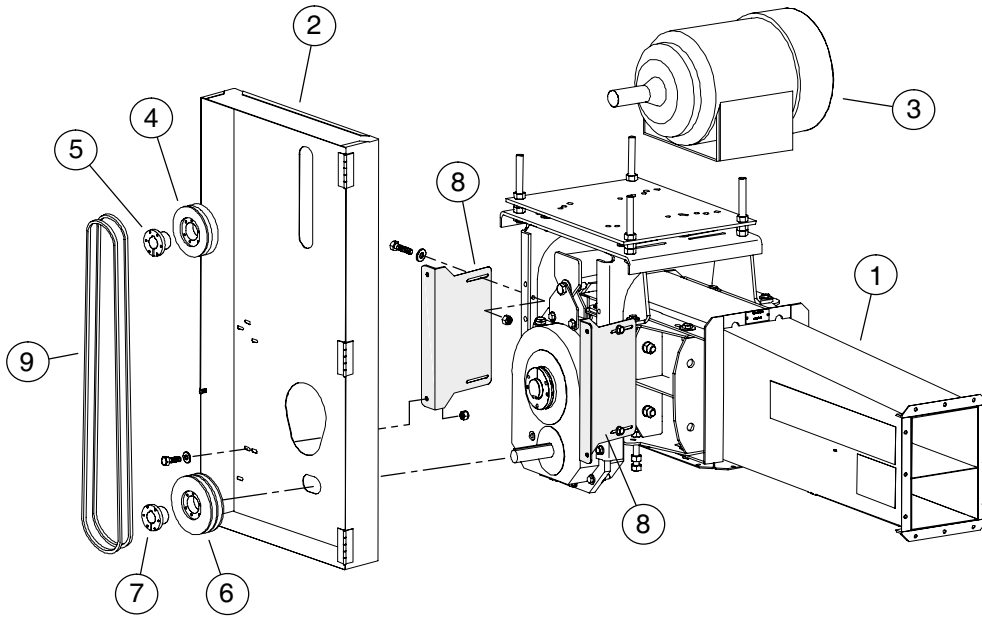

### M85322C6 - 4000 BPH - 150 FPM - 43 RPM - 5 HP

Item	Part No.	Description	Qty.
1	1044625	Wldmnt, M85 Mss tr Mvr Hd Hsng f/ Trq Arm II Drvs (30" opening)	1
2	1043083	Belt Grd Wldmnt Lrg f/ Mss Ter Mvr Hd Drv w/ Trq Arm II Red.	1
3	Motor Ref.	5 HP 3 Phs Motor	1
4	3236A1	Sheave - 4.2 - 1B Drive	1
5	3079A1	Bushing - SH 1 1/8" Drive	1
6	3307A1	Sheave, Driven QD 11.0" P.D. 1B	1
7	3047L1	Bushing, Driven QD SDS 1"	1
8	1043089	Bracket, Belt Guard f/ TA2115H15 Torque Arm II Motor Mount	2
9	40340(1)	Belt, B-81 (sheaves 29.25" center-to-center)	1

### M85323C6 - 4000 BPH - 150 FPM - 43 RPM - 7.5 HP

Item	Part No.	Description	Qty.
1	1044625	Wldmnt, M85 Mss tr Mvr Hd Hsng f/ Trq Arm II Drvs (30" opening)	1
2	1043083	Belt Grd Wldmnt Lrg f/ Mss Ter Mvr Hd Drv w/ Trq Arm II Red.	1
3	Motor Ref.	7.5 HP 3 Phs Motor	1
4	1024515	Sheave - 4.2 - 2B Drive	1
5	3086A1	Bushing - SH 1 3/8" Drive	1
6	3308A1	Sheave, Driven QD 11.0" P.D. 2B	1
7	3188A1	Bushing, Driven QD SK 1 1/8"	1
8	1043089	Bracket, Belt Guard f/ TA2115H15 Torque Arm II Motor Mount	2
9	40340(2)	Belt, B-81 (sheaves 29.25" center-to-center)	2

# PARTS LIST

Drive Assemblies M85322C6, M85323C6, M85331C6, M85332C6,  
M85339C6, M85340C6, M85348C6, M85361C6 (con't.)

## M85331C6 - 5500 BPH - 200 FPM - 57 RPM - 7.5 HP

Item	Part No.	Description	Qty.
1	1044625	Wldmnt, M85 Mss tr Mvr Hd Hsng f/ Trq Arm II Drvs (30° opening)	1
2	1043083	Belt Grd Wldmnt Lrg f/ Mss Ter Mvr Hd Drv w/ Trq Arm II Red.	1
3	Motor Ref.	7.5 HP 3 Phs Motor	1
4	1024515	Sheave - 4.2 - 2B Drive	1
5	3086A1	Bushing - SH 1 3/8" Drive	1
6	3090A1	Sheave, Driven QD 8.6" P.D. 2B	1
7	3188A1	Bushing, Driven QD SK 1 1/8"	1
8	1043089	Bracket, Belt Guard f/ TA2115H15 Torque Arm II Motor Mount	2
9	40128(2)	Belt, B-78 (sheaves 29.75" center-to-center)	2

## M85332C6 - 5500 BPH - 200 FPM - 57 RPM - 10 HP

Item	Part No.	Description	Qty.
1	1044625	Wldmnt, M85 Mss tr Mvr Hd Hsng f/ Trq Arm II Drvs (30° opening)	1
2	1043083	Belt Grd Wldmnt Lrg f/ Mss Ter Mvr Hd Drv w/ Trq Arm II Red.	1
3	Motor Ref.	10 HP 3 Phs Motor	1
4	1024515	Sheave - 4.2 - 2B Drive	1
5	3086A1	Bushing - SH 1 3/8" Drive	1
6	3090A1	Sheave, Driven QD 8.6" P.D. 2B	1
7	3188A1	Bushing, Driven QD SK 1 1/8"	1
8	1043089	Bracket, Belt Guard f/ TA2115H15 Torque Arm II Motor Mount	2
9	40128(2)	Belt, B-78 (sheaves 29.75" center-to-center)	2

## M85339C6 - 7000 BPH - 250 FPM - 72 RPM - 7.5 HP

Item	Part No.	Description	Qty.
1	1044625	Wldmnt, M85 Mss tr Mvr Hd Hsng f/ Trq Arm II Drvs (30° opening)	1
2	1043083	Belt Grd Wldmnt Lrg f/ Mss Ter Mvr Hd Drv w/ Trq Arm II Red.	1
3	Motor Ref.	7.5 HP 3 Phs Motor	1
4	1024515	Sheave - 4.2 - 2B Drive	1
5	3086A1	Bushing - SH 1 3/8" Drive	1
6	3265A1	Sheave, Driven QD 6.4" P.D. 2B	1
7	3077A1	Bushing, Driven QD SDS 1 1/8"	1
8	1043089	Bracket, Belt Guard f/ TA2115H15 Torque Arm II Motor Mount	2
9	1009129(2)	Belt, B-73 (sheaves 29" center-to-center)	2

## M85340C6 - 7000 BPH - 250 FPM - 72 RPM - 10 HP

Item	Part No.	Description	Qty.
1	1044625	Wldmnt, M85 Mss tr Mvr Hd Hsng f/ Trq Arm II Drvs (30° opening)	1
2	1043083	Belt Grd Wldmnt Lrg f/ Mss Ter Mvr Hd Drv w/ Trq Arm II Red.	1
3	Motor Ref.	10 HP 3 Phs Motor	1
4	1024515	Sheave - 4.2 - 2B Drive	1
5	3086A1	Bushing - SH 1 3/8" Drive	1
6	3265A1	Sheave, Driven QD 6.4" P.D. 2B	1
7	3077A1	Bushing, Driven QD SDS 1 1/8"	1
8	1043089	Bracket, Belt Guard f/ TA2115H15 Torque Arm II Motor Mount	2
9	1009129(2)	Belt, B-73 (sheaves 29" center-to-center)	2

continued on Page P-42

# PARTS LIST

Drive Assemblies M85322C6, M85323C6, M85331C6, M85332C6, M85339C6, M85340C6, M85348C6, M85361C6 (con't.)

**Drive Assemblies**

**M85322C6, M85323C6, M85331C6,  
M85332C6, M85339C6, M85340C6,  
M85348C6, M85361C6**

f/ Head Assembly 1044681

**M85 Assembly w/ TA2115H15 Reducer**

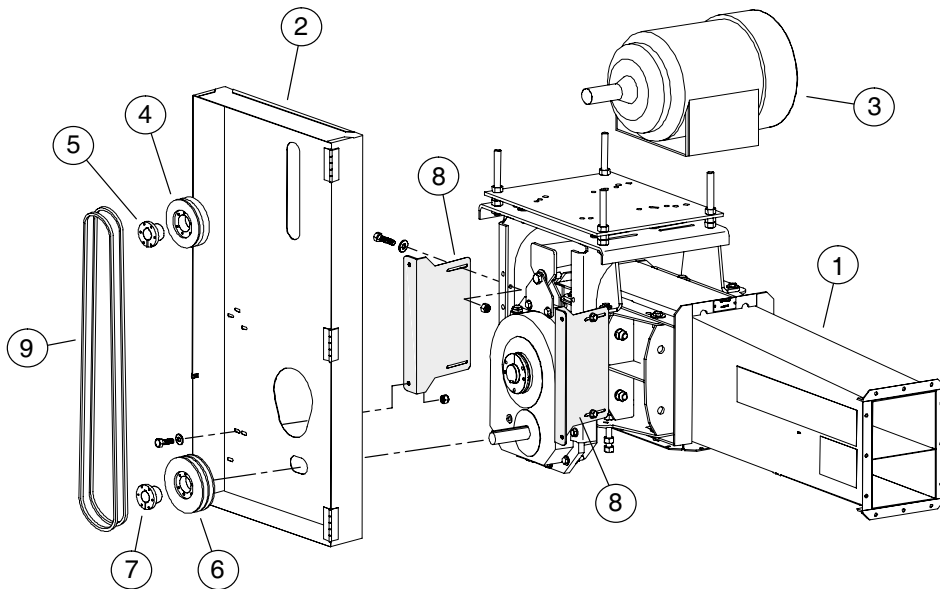

**M85348C6 - 8500 BPH - 300 FPM - 86 RPM - 10 HP**

Item	Part No.	Description	Qty.
1	1044625	Wldmnt, M85 Mss tr Mvr Hd Hsng f/ Trq Arm II Drvs (30° opening)	1
2	1043083	Belt Grd Wldmnt Lrg f/ Mss Ter Mvr Hd Drv w/ Trq Arm II Red.	1
3	Motor Ref.	10 HP 3 Phs Motor	1
4	3083A1	Sheave - 4.6 - 2B Drive	1
5	3087A1	Bushing - SDS 1 3/8" Drive	1
6	3233A1	Sheave, Driven QD 6.0" P.D. 2B	1
7	3077A1	Bushing, Driven QD SDS 1 1/8"	1
8	1043089	Bracket, Belt Guard f/ TA2115H15 Torque Arm II Motor Mount	2
9	1009129(2)	Belt, B-73 (sheaves 29" center-to-center)	2

**M85361C6 - 10,000 BPH - 400 FPM - 115 RPM - 15 HP**

Item	Part No.	Description	Qty.
1	1044625	Wldmnt, M85 Mss tr Mvr Hd Hsng f/ Trq Arm II Drvs (30° opening)	1
2	1043083	Belt Grd Wldmnt Lrg f/ Mss Ter Mvr Hd Drv w/ Trq Arm II Red.	1
3	Motor Ref.	15 HP 3 Phs Motor	1
4	3265A1	Sheave - 6.4 - 2B Drive	1
5	3183A1	Bushing - SDS 1 5/8" Drive	1
6	1026409	Sheave, Driven QD 6.2" P.D. 2B	1
7	3077A1	Bushing, Driven QD SDS 1 1/8"	1
8	1043089	Bracket, Belt Guard f/ TA2115H15 Torque Arm II Motor Mount	2
9	40127(2)	Belt, B-75 (sheaves 28.5" center-to-center)	2

## **DRIVE ASSEMBLIES, MODEL 85**

**Drive Assemblies**  
**M85324C6, M85333C6, M85341C6,**  
**M85349C6, M85350C6**  
**f/ Head Assembly 1044682**  
**M85 Assembly w/ TA3203H15 Reducer**

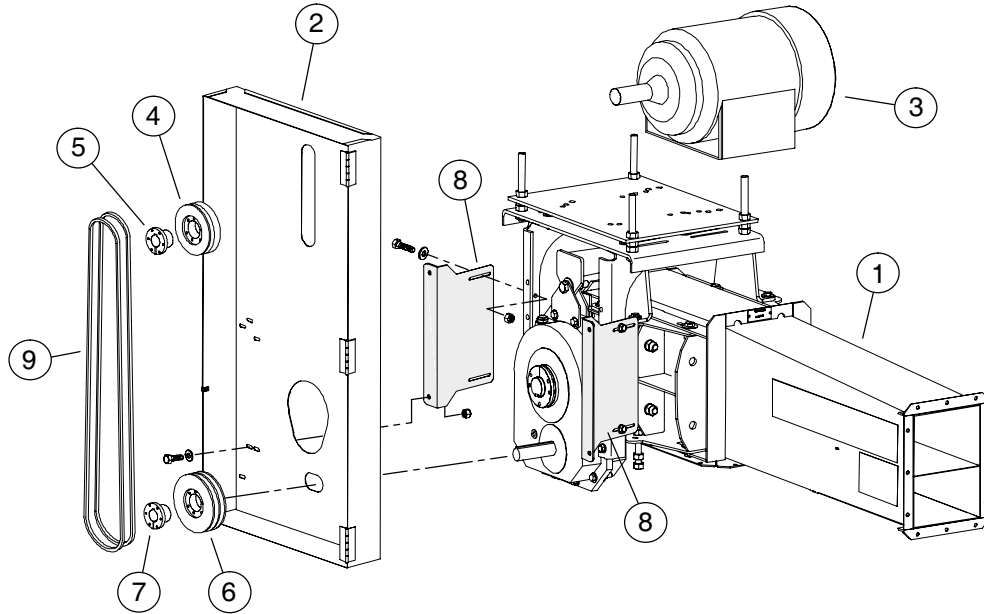

**M85324C6 - 4000 BPH - 150 FPM - 43 RPM - 10 HP**

Item	Part No.	Description	Qty.
1	1044625	Wldmnt, M85 Mss tr Mvr Hd Hsng f/ Trq Arm II Drvs (30" opening)	1
2	1043079	Belt Grd Wldmnt Lrg f/ Mss Ter Mvr Hd Drv w/ Trq Arm II Red.	1
3	Motor Ref.	10 HP 3 Phs Motor	1
4	1024515	Sheave - 4.2 - 2B Drive	1
5	3086A1	Bushing - SH 1 3/8" Drive	1
6	3308A1	Sheave, Driven QD 11.0" P.D. 2B	1
7	3190A1	Bushing, Driven QD SK 1 3/8"	1
8	1043090	Bracket, Belt Guard f/ TA3203H15 Torque Arm II Motor Mount	2
9	1023084(2)	Belt, B-84 (sheaves 30.75" center-to-center)	2

continued on Page P-44

# PARTS LIST

**Drive Assemblies M85324C6, M85333C6,  
M85341C6, M85349C6, M85350C6 (con't.)**
**M85333C6 - 5500 BPH - 200 FPM - 57 RPM - 15 HP**

Item	Part No.	Description	Qty.
1	1044625	Wldmnt, M85 Mss tr Mvr Hd Hsng f/ Trq Arm II Drvs (30° opening)	1
2	1043079	Belt Grd Wldmnt Lrg f/ Mss Ter Mvr Hd Drv w/ Trq Arm II Red.	1
3	Motor Ref.	15 HP 3 Phs Motor	1
4	1024516	Sheave - 4.2 - 3B Drive	1
5	40018	Bushing - SH 1 5/8" Drive	1
6	3270A1	Sheave, Driven QD 8.6" P.D. 3B	1
7	3190A1	Bushing, Driven QD SK 1 3/8"	1
8	1043090	Bracket, Belt Guard f/ TA3203H15 Torque Arm II Motor Mount	2
9	40340(3)	Belt, B-81 (sheaves 31.25" center-to-center)	3

**M85341C6 - 7000 BPH - 250 FPM - 72 RPM - 15 HP**

Item	Part No.	Description	Qty.
1	1044625	Wldmnt, M85 Mss tr Mvr Hd Hsng f/ Trq Arm II Drvs (30° opening)	1
2	1043079	Belt Grd Wldmnt Lrg f/ Mss Ter Mvr Hd Drv w/ Trq Arm II Red.	1
3	Motor Ref.	15 HP 3 Phs Motor	1
4	3263A1	Sheave - 5.4 - 2B Drive	1
5	3183A1	Bushing - SDS 1 5/8" Drive	1
6	3090A1	Sheave, Driven QD 8.6" P.D. 2B	1
7	3190A1	Bushing, Driven QD SK 1 3/8"	1
8	1043090	Bracket, Belt Guard f/ TA3203H15 Torque Arm II Motor Mount	2
9	1023084(2)	Belt, B-84 (sheaves 31.875" center-to-center)	2

**M85349C6 - 8500 BPH - 300 FPM - 86 RPM - 15 HP**

Item	Part No.	Description	Qty.
1	1044625	Wldmnt, M85 Mss tr Mvr Hd Hsng f/ Trq Arm II Drvs (30° opening)	1
2	1043079	Belt Grd Wldmnt Lrg f/ Mss Ter Mvr Hd Drv w/ Trq Arm II Red.	1
3	Motor Ref.	15 HP 3 Phs Motor	1
4	3263A1	Sheave - 5.4 - 2B Drive	1
5	3183A1	Bushing - SDS 1 5/8" Drive	1
6	3235A1	Sheave, Driven QD 7.4" P.D. 2B	1
7	3190A1	Bushing, Driven QD SK 1 3/8"	1
8	1043090	Bracket, Belt Guard f/ TA3203H15 Torque Arm II Motor Mount	2
9	40340(2)	Belt, B-81 (sheaves 31.375" center-to-center)	2

**M85350C6 - 8500 BPH - 300 FPM - 86 RPM - 20 HP**

Item	Part No.	Description	Qty.
1	1044625	Wldmnt, M85 Mss tr Mvr Hd Hsng f/ Trq Arm II Drvs (30° opening)	1
2	1043079	Belt Grd Wldmnt Lrg f/ Mss Ter Mvr Hd Drv w/ Trq Arm II Red.	1
3	Motor Ref.	20 HP 3 Phs Motor	1
4	3276A1	Sheave - 5.4 - 3B Drive	1
5	3089A1	Bushing - SD 1 5/8" Drive	1
6	3244A1	Sheave, Driven QD 7.4" P.D. 3B	1
7	3190A1	Bushing, Driven QD SK 1 3/8"	1
8	1043090	Bracket, Belt Guard f/ TA3203H15 Torque Arm II Motor Mount	2
9	40340(3)	Belt, B-81 (sheaves 31.375" center-to-center)	3

## DRIVE ASSEMBLIES, MODEL 85

**Drive Assemblies**  
**M85326C6, M85335C6, M85342C6,**  
**M85344C6, M85351C6,**  
**M85352C6, M85355C6, M85356C6,**  
**M85353C6**  
**f/ Head Assembly 1044683**  
**M85 Assembly w/ TA4207H15 Reducer**

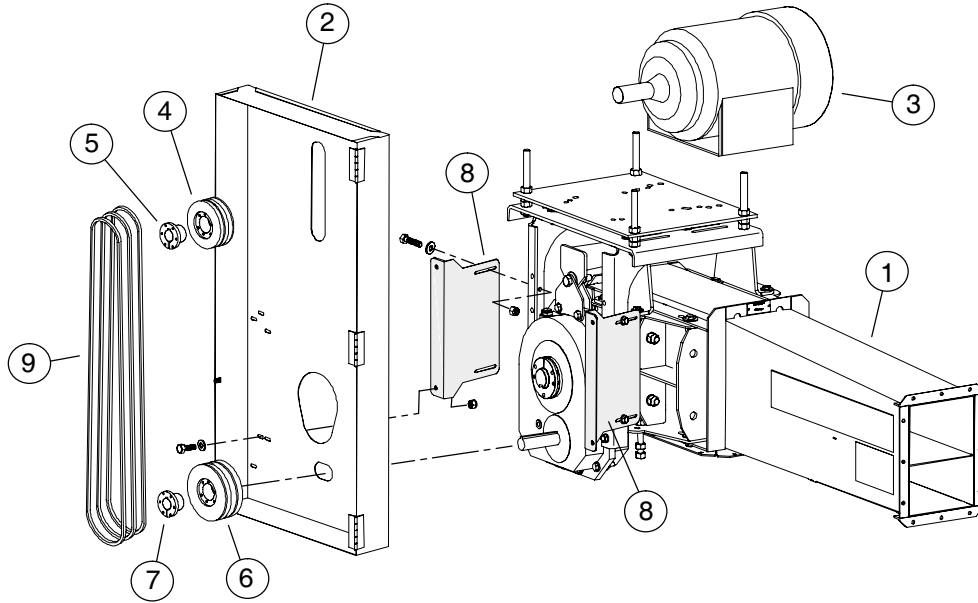

### M85326C6 - 4000 BPH - 150 FPM - 43 RPM - 15 HP

Item	Part No.	Description	Qty.
1	1044625	Wldmnt, M85 Mss tr Mvr Hd Hsng f/ Trq Arm II Drvs (30° opening)	1
2	1043079	Belt Grd Wldmnt Lrg f/ Mss Ter Mvr Hd Drv w/ Trq Arm II Red.	1
3	Motor Ref.	15 HP 3 Phs Motor	1
4	1024516	Sheave - 4.2 - 3B Drive	1
5	40018	Bushing - SH 1 5/8" Drive	1
6	3271A1	Sheave, Driven QD 11.0" P.D. 3B	1
7	3191A1	Bushing, Driven QD SK 1 7/16"	1
8	1043091	Bracket, Belt Guard f/ TA4207H15 Torque Arm II Motor Mount	2
9	40132(3)	Belt, B-97 (sheaves 37.31" center-to-center)	3

continued on Page P-46

# PARTS LIST

**Drive Assemblies M85326C6, M85335C6,  
M85342C6, M85344C6, M85351C6, M85352C6,  
M85355C6, M85356C6, M85353C6 (con't.)**

### M85335C6 - 5500 BPH - 200 FPM - 57 RPM - 20 HP

Item	Part No.	Description	Qty.
1	1044625	Wldmnt, M85 Mss tr Mvr Hd Hsng f/ Trq Arm II Drvs (30° opening)	1
2	1043079	Belt Grd Wldmnt Lrg f/ Mss Ter Mvr Hd Drv w/ Trq Arm II Red.	1
3	Motor Ref.	20 HP 3 Phs Motor	1
4	3248A1	Sheave - 4.2 - 4B Drive	1
5	3189A1	Bushing - SD 1 5/8" Drive	1
6	3273A1	Sheave, Driven QD 8.6" P.D. 4B	1
7	3191A1	Bushing, Driven QD SK 1 7/16"	1
8	1043091	Bracket, Belt Guard f/ TA4207H15 Torque Arm II Motor Mount	2
9	1016262(4)	Belt, B-93 (sheaves 37.29" center-to-center)	4

### M85342C6 - 7000 BPH - 250 FPM - 72 RPM - 20 HP

Item	Part No.	Description	Qty.
1	1044625	Wldmnt, M85 Mss tr Mvr Hd Hsng f/ Trq Arm II Drvs (30° opening)	1
2	1043079	Belt Grd Wldmnt Lrg f/ Mss Ter Mvr Hd Drv w/ Trq Arm II Red.	1
3	Motor Ref.	20 HP 3 Phs Motor	1
4	3276A1	Sheave - 5.4 - 3B Drive	1
5	3089A1	Bushing - SD 1 5/8" Drive	1
6	3270A1	Sheave, Driven QD 8.6" P.D. 3B	1
7	3191A1	Bushing, Driven QD SK 1 7/16"	1
8	1043091	Bracket, Belt Guard f/ TA4207H15 Torque Arm II Motor Mount	2
9	1016262(3)	Belt, B-93 (sheaves 36.375" center-to-center)	3

### M85344C6 - 7000 BPH - 250 FPM - 72 RPM - 25 HP

Item	Part No.	Description	Qty.
1	1044625	Wldmnt, M85 Mss tr Mvr Hd Hsng f/ Trq Arm II Drvs (30° opening)	1
2	1043079	Belt Grd Wldmnt Lrg f/ Mss Ter Mvr Hd Drv w/ Trq Arm II Red.	1
3	Motor Ref.	25 HP 3 Phs Motor	1
4	3242A1	Sheave - 6.0 - 3B Drive	1
5	3280A1	Bushing - SD 1 7/8" Drive	1
6	3080A1	Sheave, Driven QD 9.4" P.D. 3B	1
7	3191A1	Bushing, Driven QD SK 1 7/16"	1
8	1043091	Bracket, Belt Guard f/ TA4207H15 Torque Arm II Motor Mount	2
9	40132(3)	Belt, B-97 (sheaves 37.25" center-to-center)	3

### M85351C6 - 8500 BPH - 300 FPM - 86 RPM - 25 HP

Item	Part No.	Description	Qty.
1	1044625	Wldmnt, M85 Mss tr Mvr Hd Hsng f/ Trq Arm II Drvs (30° opening)	1
2	1043079	Belt Grd Wldmnt Lrg f/ Mss Ter Mvr Hd Drv w/ Trq Arm II Red.	1
3	Motor Ref.	25 HP 3 Phs Motor	1
4	3276A1	Sheave - 5.4 - 3B Drive	1
5	3280A1	Bushing - SD 1 7/8" Drive	1
6	3244A1	Sheave, Driven QD 7.4" P.D. 3B	1
7	3191A1	Bushing, Driven QD SK 1 7/16"	1
8	1043091	Bracket, Belt Guard f/ TA4207H15 Torque Arm II Motor Mount	2
9	1016262(3)	Belt, B-93 (sheaves 37.375" center-to-center)	3

continued on Page P-47

# PARTS LIST

Drive Assemblies M85326C6, M85335C6,  
M85342C6, M85344C6, M85351C6, M85352C6,  
M85355C6, M85356C6, M85353C6 (con't.)

## M85352C6 - 8500 BPH - 300 FPM - 86 RPM - 30 HP

Item	Part No.	Description	Qty.
1	1044625	Wldmnt, M85 Mss tr Mvr Hd Hsng f/ Trq Arm II Drvs (30" opening)	1
2	1043079	Belt Grd Wldmnt Lrg f/ Mss Ter Mvr Hd Drv w/ Trq Arm II Red.	1
3	Motor Ref.	30 HP 3 Phs Motor	1
4	3268A1	Sheave - 6.4 - 3B Drive	1
5	3280A1	Bushing - SD 1 7/8" Drive	1
6	3270A1	Sheave, Driven QD 8.6" P.D. 3B	1
7	3191A1	Bushing, Driven QD SK 1 7/16"	1
8	1043091	Bracket, Belt Guard f/ TA4207H15 Torque Arm II Motor Mount	2
9	40132(3)	Belt, B-97 (sheaves 37.625" center-to-center)	3

## M85355C6 - 10,000 BPH - 400 FPM - 115 RPM - 20 HP

Item	Part No.	Description	Qty.
1	1044625	Wldmnt, M85 Mss tr Mvr Hd Hsng f/ Trq Arm II Drvs (30" opening)	1
2	1043079	Belt Grd Wldmnt Lrg f/ Mss Ter Mvr Hd Drv w/ Trq Arm II Red.	1
3	Motor Ref.	20 HP 3 Phs Motor	1
4	3266A1	Sheave - 6.8 - 2B Drive	1
5	3183A1	Bushing - SDS 1 5/8" Drive	1
6	3266A1	Sheave, Driven QD 6.8" P.D. 2B	1
7	3277A1	Bushing, Driven QD SDS 1 7/16"	1
8	1043091	Bracket, Belt Guard f/ TA4207H15 Torque Arm II Motor Mount	2
9	1016262(2)	Belt, B-93 (sheaves 36.75" center-to-center)	2

## M85356C6 - 10,000 BPH - 400 FPM - 115 RPM - 25 HP

Item	Part No.	Description	Qty.
1	1044625	Wldmnt, M85 Mss tr Mvr Hd Hsng f/ Trq Arm II Drvs (30" opening)	1
2	1043079	Belt Grd Wldmnt Lrg f/ Mss Ter Mvr Hd Drv w/ Trq Arm II Red.	1
3	Motor Ref.	25 HP 3 Phs Motor	1
4	3269A1	Sheave - 6.8 - 3B Drive	1
5	3280A1	Bushing - SD 1 7/8" Drive	1
6	3269A1	Sheave, Driven QD 6.8" P.D. 3B	1
7	3278A1	Bushing, Driven QD SD 1 7/16"	1
8	1043091	Bracket, Belt Guard f/ TA4207H15 Torque Arm II Motor Mount	2
9	1016262(3)	Belt, B-93 (sheaves 36.75" center-to-center)	3

## M85353C6 - 10,000 BPH - 400 FPM - 115 RPM - 40 HP

Item	Part No.	Description	Qty.
1	1044625	Wldmnt, M85 Mss tr Mvr Hd Hsng f/ Trq Arm II Drvs (30" opening)	1
2	1043079	Belt Grd Wldmnt Lrg f/ Mss Ter Mvr Hd Drv w/ Trq Arm II Red.	1
3	Motor Ref.	40 HP 3 Phs Motor	1
4	3270A1	Sheave - 8.6 - 3B Drive	1
5	3281A1	Bushing - SK 2 1/8" Drive	1
6	3270A1	Sheave, Driven QD 8.6" P.D. 3B	1
7	3191A1	Bushing, Driven QD SK 1 7/16"	1
8	1043091	Bracket, Belt Guard f/ TA4207H15 Torque Arm II Motor Mount	2
9	40133(3)	Belt, B-100 (sheaves 37.375" center-to-center)	3

# PARTS LIST

## **DRIVE ASSEMBLIES, MODEL 85**

**Drive Assembly  
M85354C6, M85360C6  
f/ Head Assembly 1044684**

**M85 Assembly w/ TA5215H15 Reducer**

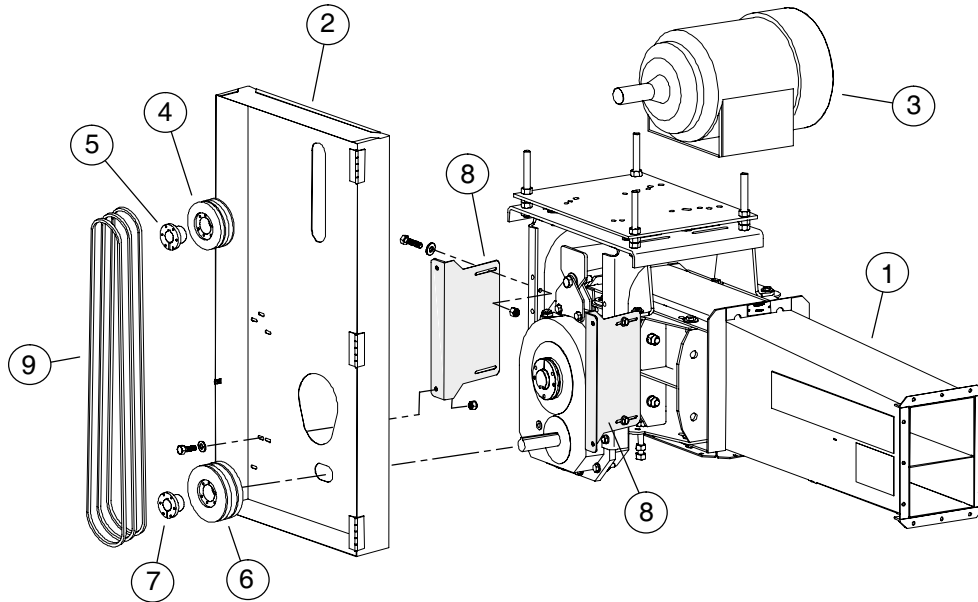

**M85354C6 - 8500 BPH - 300 FPM - 86 RPM - 40 HP**

Item	Part No.	Description	Qty.
1	1044625	Wldmnt, M85 Mss tr Mvr Hd Hsng f/ Trq Arm II Drvs (30" opening)	1
2	1043079	Belt Grd Wldmnt Lrg f/ Mss Ter Mvr Hd Drv w/ Trq Arm II Red.	1
3	Motor Ref.	40 HP 3 Phs Motor	1
4	1006114	Sheave - 8.0 - 3B Drive	1
5	3281A1	Bushing - SK 2 1/8" Drive	1
6	3271A1	Sheave, Driven QD 11.0" P.D. 3B	1
7	3192A1	Bushing, Driven QD SK 1 5/8"	1
8	1043092	Bracket, Belt Guard f/ TA5215H15 Torque Arm II Motor Mount	2
9	40133(3)	Belt, B-100 (sheaves 36" center-to-center)	3

**M85360C6 - 10,000 BPH - 400 FPM - 115 RPM - 50 HP**

Item	Part No.	Description	Qty.
1	1044625	Wldmnt, M85 Mss tr Mvr Hd Hsng f/ Trq Arm II Drvs (30" opening)	1
2	1043079	Belt Grd Wldmnt Lrg f/ Mss Ter Mvr Hd Drv w/ Trq Arm II Red.	1
3	Motor Ref.	50 HP 3 Phs Motor	1
4	3080A1	Sheave - QD 9.4 - 3B Drive	1
5	3281A1	Bushing - SK 2 1/8" Drive	1
6	3080A1	Sheave, Driven QD 9.4" P.D. 3B	1
7	3192A1	Bushing, Driven QD SK 1 5/8"	1
8	1043092	Bracket, Belt Guard f/ TA2115H15 Torque Arm II Motor Mount	2
9	40133(3)	Belt, B-100 (sheaves 36 1/8" center-to-center)	3

## **MODEL 50 VERTICAL DRIVE HEAD**

**f/ 3 HP & 5 HP UNITS**

**M50515C4 & M50516C4**

**f/ Head Assembly**

**1010116**

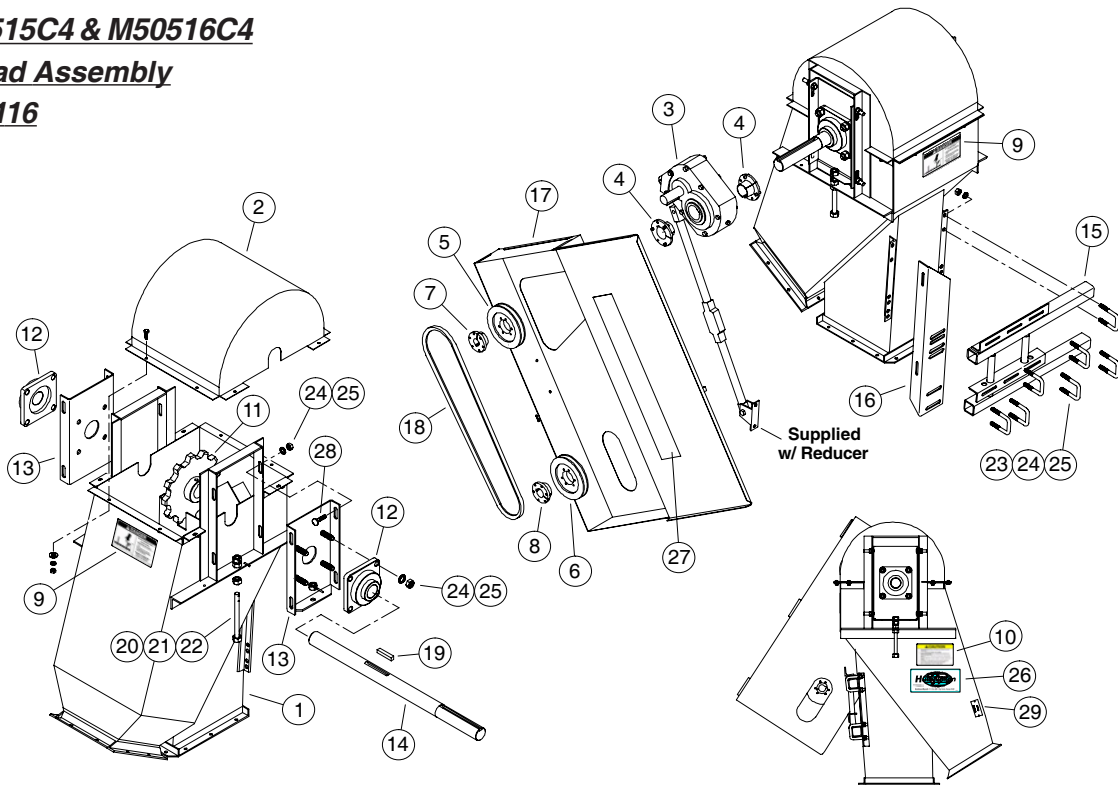

Ref. No.	Part No.	Description
1	1004921	Head, Vertical Drive
(1)	1004921-AR	Head, Vertical Drive
(1)	1004921-ARS	Head, Vertical Drive
2	630203	Cover f/ Vertical Head Drive
3	3001L91	Reducer, TXT 115 (3 & 5 hp)
4	3009L91	Reducer Bushing Kit (3 & 5 hp)
5	3309A1	Sheave, QD 1-B 5.2"
6	3257A1	Sheave, QD 1-B 5.4"
7	3182A1	Bushing, QD SDS 3/4"
8	3077A1	Bushing, QD SDS 1 1/8"
9	1002311	Decal, Danger: Moving Chain...
10	1002301	Decal, Caution: General Operator
11	1005566	Sprocket, 12T 1 1/2" bore
12	1010A	Bearing, 1 1/2" Flange 4-Hole
13	62263	Slide Take-Up
14	550308	Shaft, 1 1/2" dia.

Ref. No.	Part No.	Description
15	631332	Frame, Motor Mount (3 & 5 hp)
16	553575	Bracket, Belt Guard Mount
17	130258	Belt Guard (f/ 3 & 5 hp)
18	40123	Belt, B-64
19	4073A1	Key, 3/8" sq. x 3" long
20	60951	Bolt, Bearing Take-Up
21	31121	Roll Pin, 3/16" x 1" long
22	D1170	Nut, 5/8"-11 Non-Lock PLT
23	33240	U-Bolt, 1/2" w/ 2 1/8" spread
24	D1143	Washer, 1/2" Lock PLT
25	D1169	Nut, 1/2"-13 Non-Lock PLT
26	1001128	Decal, Hutchinson Globe
27	1001125	Decal, Hutchinson (rectangle)
28	1002243	Bolt, 1/2"-13 x 1 1/2" Carriage
29	34687	Serial Number Plate

The Belt Guard (Item 17) and Cover (Item 2) are attached using:

- 4701-1 5/16"-18 x 3/4" Bolts
- 33023 5/16" Flat Washers
- 33144 5/16" Lock Washers
- 33151 5/16"-18 Non-Lock Nuts

The Complete Assembly can be Obtained, Order Part No. 1010116 (complete assembly includes all items shown)

# PARTS LIST

## **MODEL 50 VERTICAL DRIVE HEAD**

### **f/ 7 1/2 HP UNITS**

#### **M50517C4**

#### **f/ Head Assembly**

#### **1006267**

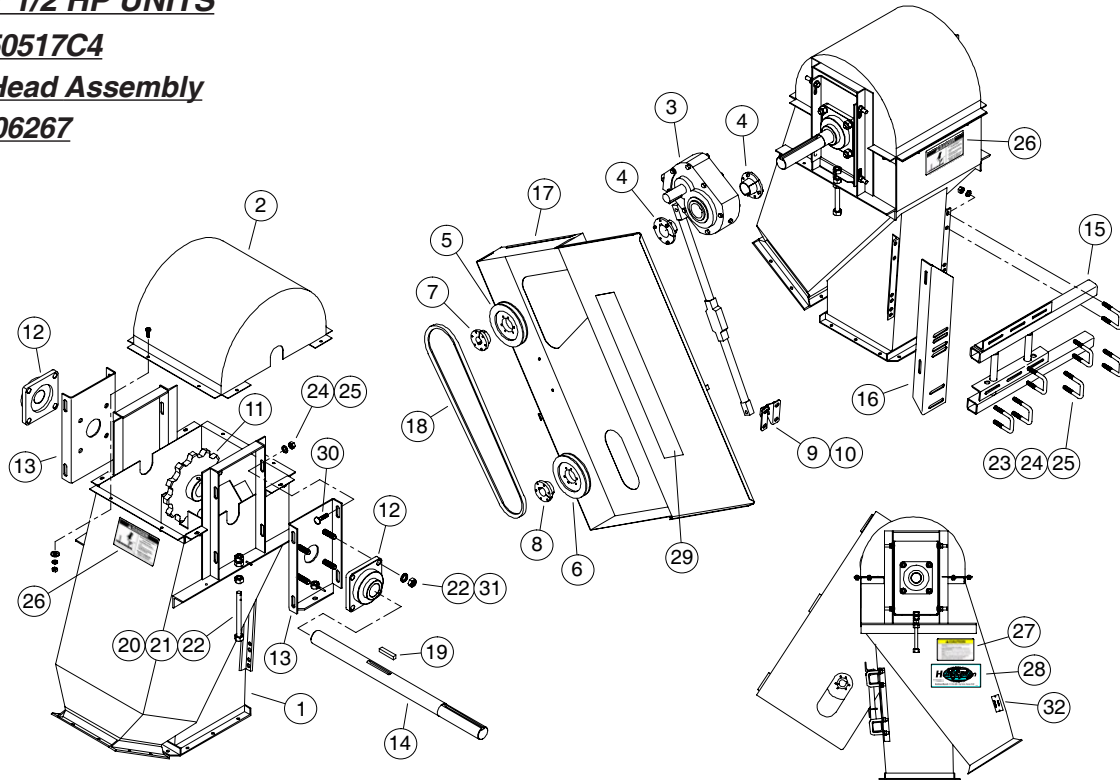

Ref. No.	Part No.	Description	Ref. No.	Part No.	Description
1	1004921	Head, Vertical Drive	16	553575	Bracket, Belt Guard Mount
(1)	1004921-AR	Head, Vertical Drive	17	130288	Belt Guard f/ 7.5 hp Units
(1)	1004921-ARS	Head, Vertical Drive	18	40125	Belt, B-68
2	630203	Cover f/ Vertical Head Drive	19	4021L1	Key, 1/2" sq. x 2 3/4" long
3	3002L91	Reducer, TXT 215 (7.5 hp)	20	60951	Bolt Take-Up Assembly
4	3010L91	Reducer Bushing Kit (7.5 hp)	21	31121	Roll Pin, 3/16" x 1" long
5	3259A1	Sheave, QD 1-B 6.4"	22	D1170	Nut, 5/8"-10 Non-Lock PLT
6	3239A1	Sheave, QD 1-B 6.0"	23	33240	U-Bolt, 1/2" w/ 2 1/8" spread
7	3077A1	Bushing QD SDS 1 1/8"	24	D1143	Washer, 1/2" Lock PLT
8	3087A1	Bushing, QD SDS 1 3/8"	25	D1169	Nut, 1/2"-13 Non-Lock PLT
9	1015236	Bracket, Bolt-On left	26	1002311	Decal, Danger: Moving Chain...
10	1015235	Bracket, Bolt-On right	27	1002301	Decal, Caution: General Operator
11	1005565	Sprocket, 12T 2" bore	28	1001128	Decal, Hutchinson Globe
12	2214C	Bearing, 2" Flange	29	1001125	Decal, Hutchinson (rectangle)
13	61223	Slide Take-Up	30	1002243	Bolt, 1/2"-13 x 1 1/2" Carriage
14	552625	Shaft, 2" dia.	31	D1171	Washer, 5/8" Lock PLT
15	631332	Frame, Motor Mount (7.5 hp)	32	34687	Serial Plate

The Belt Guard (Item 17) and Cover (Item 2) are attached using:

- 4701-1 5/16"-18 x 3/4" Bolts
- 33023 5/16" Flat Washers
- 33144 5/16" Lock Washers
- 33151 5/16"-18 Non-Lock Nuts

The Complete Assembly can be Obtained, Order Part No. 1006267 (complete assembly includes all items shown)

## MODEL 50 VERTICAL DRIVE HEAD

f/ 10 HP UNITS

M50518C4

f/ Head Assembly

1011594

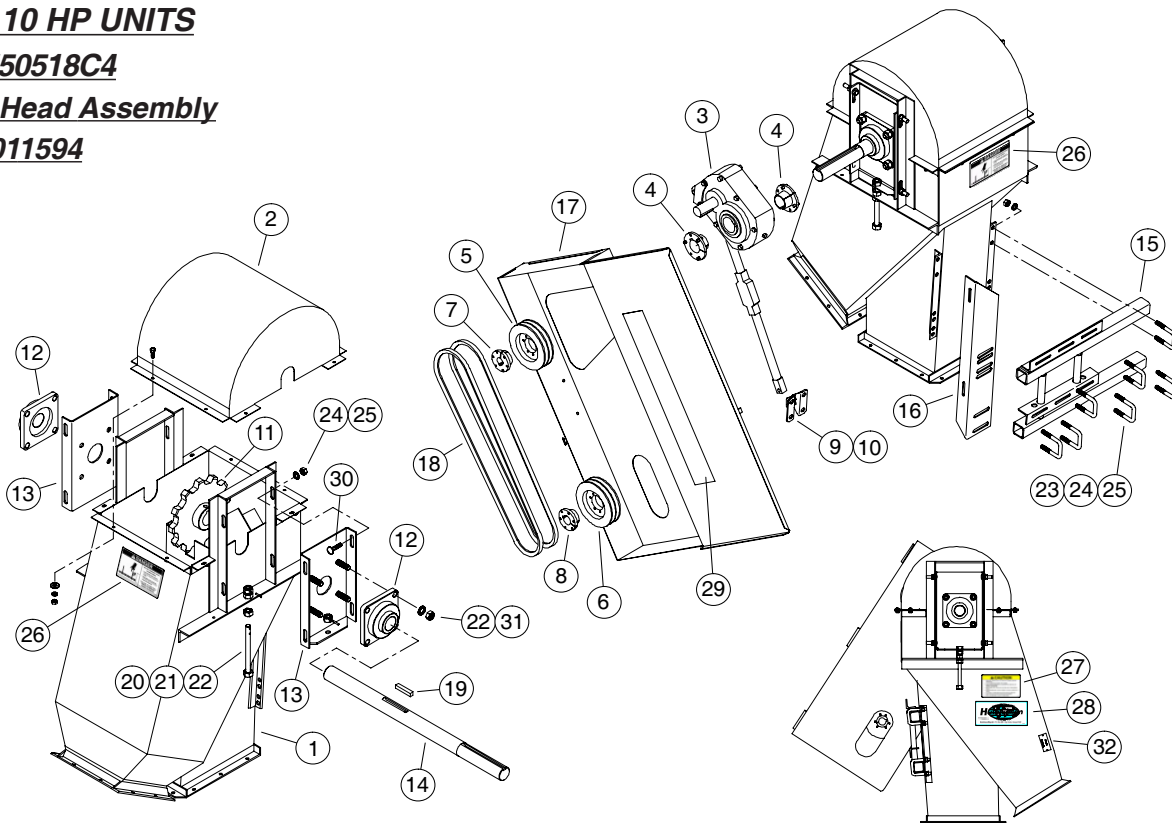

Ref. No.	Part No.	Description
1	1004921	Head, Vertical Drive
(1)	1004921-AR	Head, Vertical Drive (10 hp)
(1)	1004921-ARS	Head, Vertical Drive (10 hp)
2	630203	Cover f/ Vertical Head Drive
3	3002L91	Reducer, TXT 215 (10 hp)
4	3010L91	Reducer Bushing Kit (10 hp)
5	3266A1	Sheave, QD 2-B 6.8"
6	3265A1	Sheave, QD 2-B 6.4"
7	3077A1	Bushing QD SDS 1 1/8"
8	3087A1	Bushing, QD SDS 1 3/8"
9	1015236	Bracket, Bolt-On (left)
10	1015235	Bracket, Bolt-On (right)
11	1005565	Sprocket, 12T 2" bore
12	2214C	Bearing, 2" Flange 4-Hole
13	61223	Slide Take-Up
14	552625	Shaft, 2" dia. (10 hp)
15	631332	Frame, Motor Mount
16	553575	Mount, Belt Guard

Ref. No.	Part No.	Description
17	130288	Belt Guard f/ 10 hp Units
18	40127	Belt, B-75, 78" long
19	4021L1	Key, 1/2" sq. x 2 3/4" long
20	60951	Bolt Take-Up Assembly
21	31121	Roll Pin, 3/16" x 1" long
22	D1170	Nut, 5/8"-10 Non-Lock PLT
23	33240	U-Bolt, 1/2" w/ 2 1/8" spread
24	D1143	Washer, 1/2" Lock PLT
25	D1169	Nut, 1/2"-13 Non-Lock PLT
26	1012872	*Decal, Danger: Do Not Operate...
27	1002301	*Decal, Caution: General Operator
28	1001128	Decal, Hutchinson Globe
29	1001125	Decal, Hutchinson (rectangle)
30	1002243	Bolt, 1/2"-13 x 1 1/2" Carriage
31	D1171	Washer, 5/8" Lock PLT
32	34687	Serial Plate

The Belt Guard (Item 17) and Cover (Item 2) are attached using:

- 4701-1 5/16"-18 x 3/4" Bolts
- 33023 5/16" Flat Washers
- 33144 5/16" Lock Washers
- 33151 5/16"-18 Non-Lock Nuts

The Complete Assembly can be Obtained, Order Part No. 1011594 (complete assembly includes all items shown)

\*Decal locations may vary.

# PARTS LIST

## **MODEL 50 VERTICAL DRIVE HEAD**

### **f/ 15 HP UNITS**

### **M50519C4**

### **f/ Head Assembly**

### **1012580**

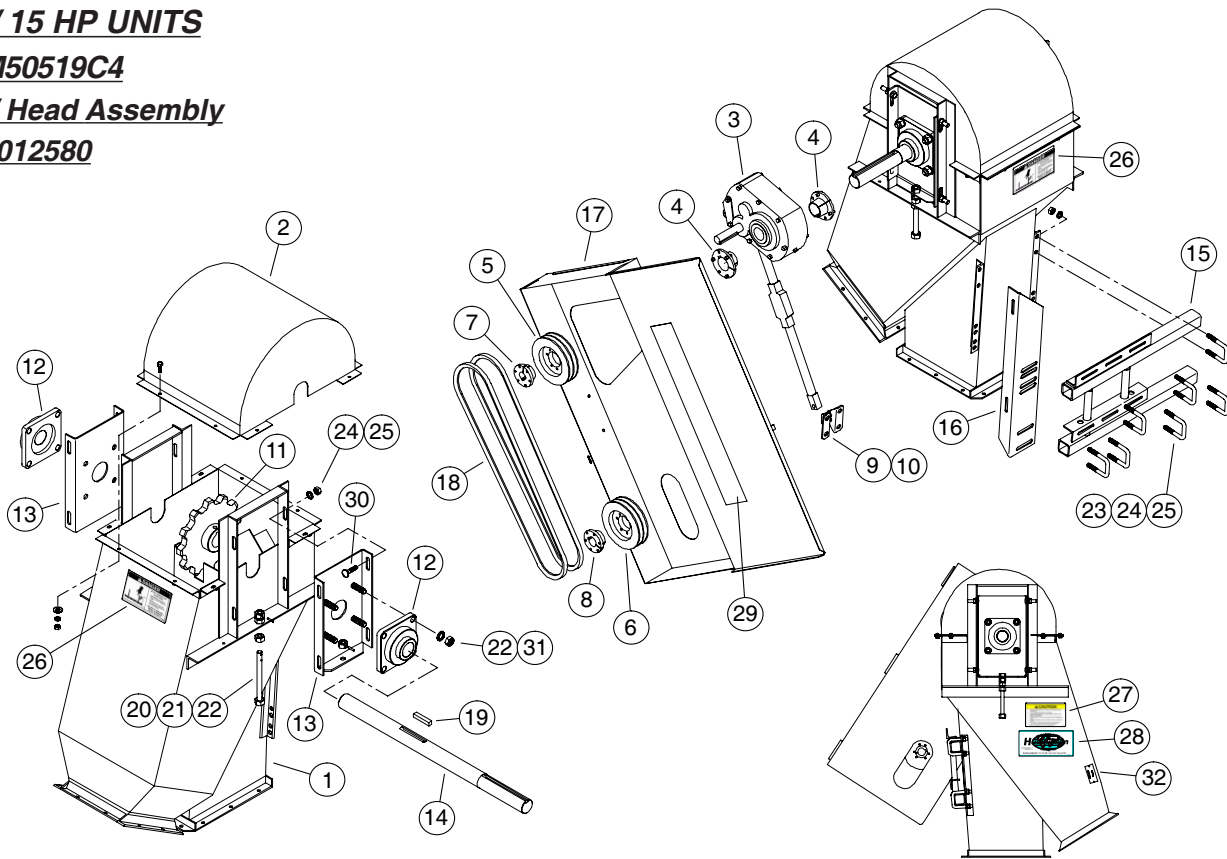

Ref. No.	Part No.	Description
1	1004921	Head, Vertical Drive
(1)	1004921-AR	Head, Vertical Drive
(1)	1004921-ARS	Head, Vertical Drive
2	630203	Cover f/ Vertical Head Drive
3	3004L91	Reducer, TXT 415 (15 hp)
4	40673	Reducer Bushing Kit (15 hp)
5	3265A1	Sheave, QD 2-B 6.4"
6	3265A1	Sheave, QD 2-B 6.4"
7	3277A1	Bushing, QD SDS 1 7/16"
8	3183A1	Bushing, QD SDS 1 5/8"
9	1015236	Bracket, Bolt-On (left)
10	1015235	Bracket, Bolt-On (right)
11	1005565	Sprocket, 12T 2" bore
12	2214C	Bearing, 2" Flange 4-Hole
13	61223	Slide Take-Up
14	550311	Shaft, 2" dia. x 36" long
15	631333	Frame, Motor Mount (15 hp)

Ref. No.	Part No.	Description
16	553575	Mount, Belt Guard
17	130288	Belt Guard f/ 15 hp Units
18	40127	Belt, B-75, 78" long
19	4021L1	Key, 1/2" sq. x 2 3/4" long
20	60951	Bolt Take-Up Assembly
21	31121	Roll Pin, 3/16" x 1" long
22	D1170	Nut, 5/8"-10 Non-Lock PLT
23	33240	U-Bolt, 1/2" w/ 2 1/8" spread
24	D1143	Washer, 1/2" Lock PLT
25	D1169	Nut, 1/2"-13 Non-Lock PLT
26	1012872	*Decal, Danger: Do Not Operate...
27	1002301	*Decal, Caution: General Operator
28	1001128	Decal, Hutchinson Globe
29	1001125	Decal, Hutchinson (rectangle)
30	1002243	Bolt, 1/2"-13 x 1 1/2" Carriage
31	D1171	Washer, 5/8" Lock PLT
32	34687	Serial Plate

The Belt Guard (Item 17) and Cover (Item 2) are attached using:

- 4701-1 5/16"-18 x 3/4" Bolts
- 33023 5/16" Flat Washers
- 33144 5/16" Lock Washers
- 33151 5/16"-18 Non-Lock Nuts

The Complete Assembly can be Obtained, Order Part No. 1012580 (complete assembly includes all items shown)

\*Decals and decal locations may vary.

## **MODEL 50 VERTICAL DRIVE HEAD**

### **f/ 20 HP UNITS**

### **M51521C4**

### **f/ Head Assembly**

### **1011050**

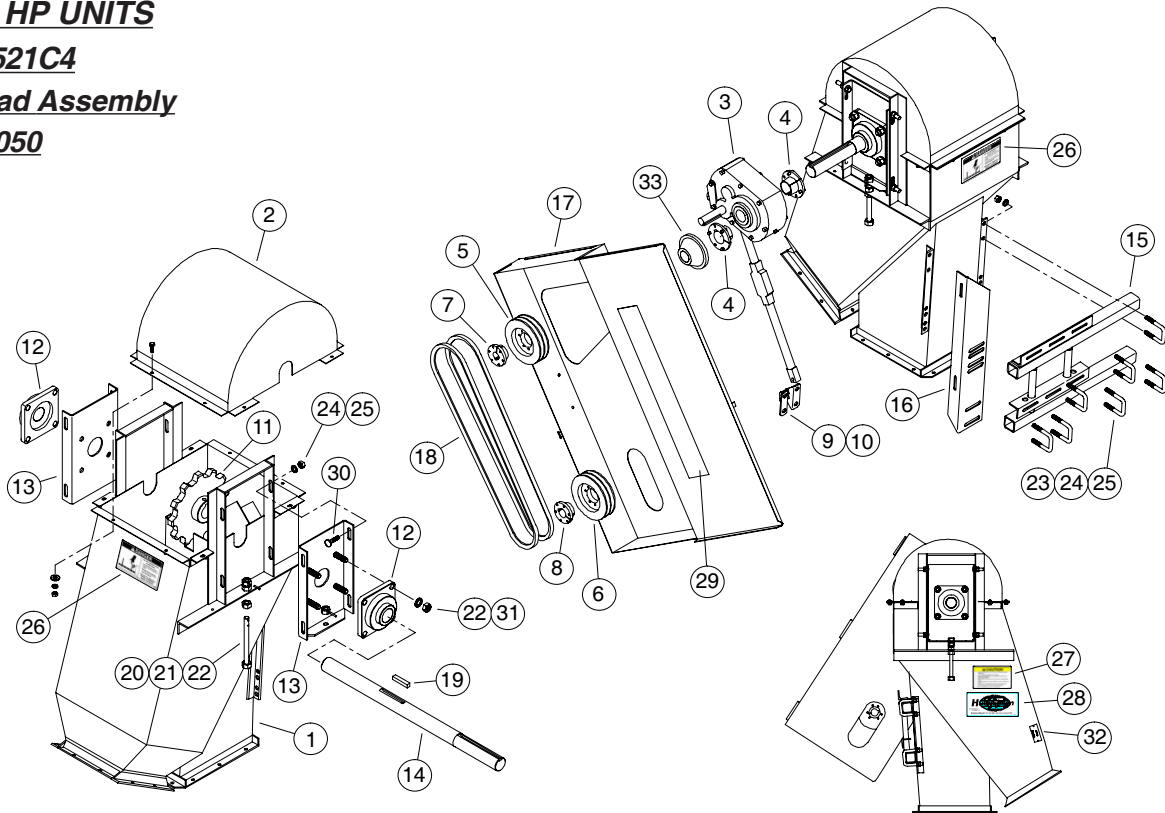

Ref. No.	Part No.	Description	Ref. No.	Part No.	Description
1	1004921	Head, Vertical Drive	17	130288	Belt Guard f/ 20 hp Units
(1)	1004921-AR	Head, Vertical Drive	18	40127	Belt, B-75, 78" long
(1)	1004921-ARS	Head, Vertical Drive	19	4021L1	Key, 1/2" sq. x 2 3/4" long
2	630203	Cover f/ Vertical Head Drive	20	60951	Bolt Take-Up Assembly
3	3004L91	Reducer, TXT 415 (20 hp)	21	31121	Roll Pin, 3/16" x 1" long
4	40673	Reducer Bushing Kit (20 hp)	22	D1170	Nut, 5/8"-10 Non-Lock PLT
5	3235A1	Sheave, QD 2-B 7.4"	23	33240	U-Bolt, 1/2" w/ 2 1/8" spread
6	3235A1	Sheave, QD 2-B 7.4"	24	D1143	Washer, 1/2" Lock PLT
7	3191A1	Bushing, QD SK 1 7/16"	25	D1169	Nut, 1/2"-13 Non-Lock PLT
8	3192A1	Bushing, QD SK 1 5/8"	26	1012872	*Decal, Danger: Do Not Operate...
9	1015236	Bracket, Bolt-On (left)	27	1002301	*Decal, Caution: General Operator
10	1015235	Bracket, Bolt-On (right)	28	1001128	Decal, Hutchinson Globe
11	1005565	Sprocket, 12T 2" bore	29	1001125	Decal, Hutchinson (rectangle)
12	2214C	Bearing, 2" Flange 4-Hole	30	1002243	Bolt, 1/2"-13 x 1 1/2" Carriage
13	61223	Slide Take-Up	31	D1171	Washer, 5/8" Lock PLT
14	550311	Shaft, 2" dia. x 36" long	32	34687	Serial Plate
15	631333	Frame, Motor Mount (20 hp)	33	41884	Cooling Fan
16	553575	Mount, Belt Guard			

The Belt Guard (Item 17) and Cover (Item 2) are attached using:

- 4701-1 5/16"-18 x 3/4" Bolts
- 33023 5/16" Flat Washers
- 33144 5/16" Lock Washers
- 33151 5/16"-18 Non-Lock Nuts

The Complete Assembly can be Obtained, Order Part No. 1011050 (complete assembly includes all items shown)

\*Decals and decal locations may vary.

# PARTS LIST

## **MODEL 50 VERTICAL DRIVE HEAD**

### **f/ 25 HP UNITS**

### **M51522C4**

### **f/ Head Assembly**

### **1037258**

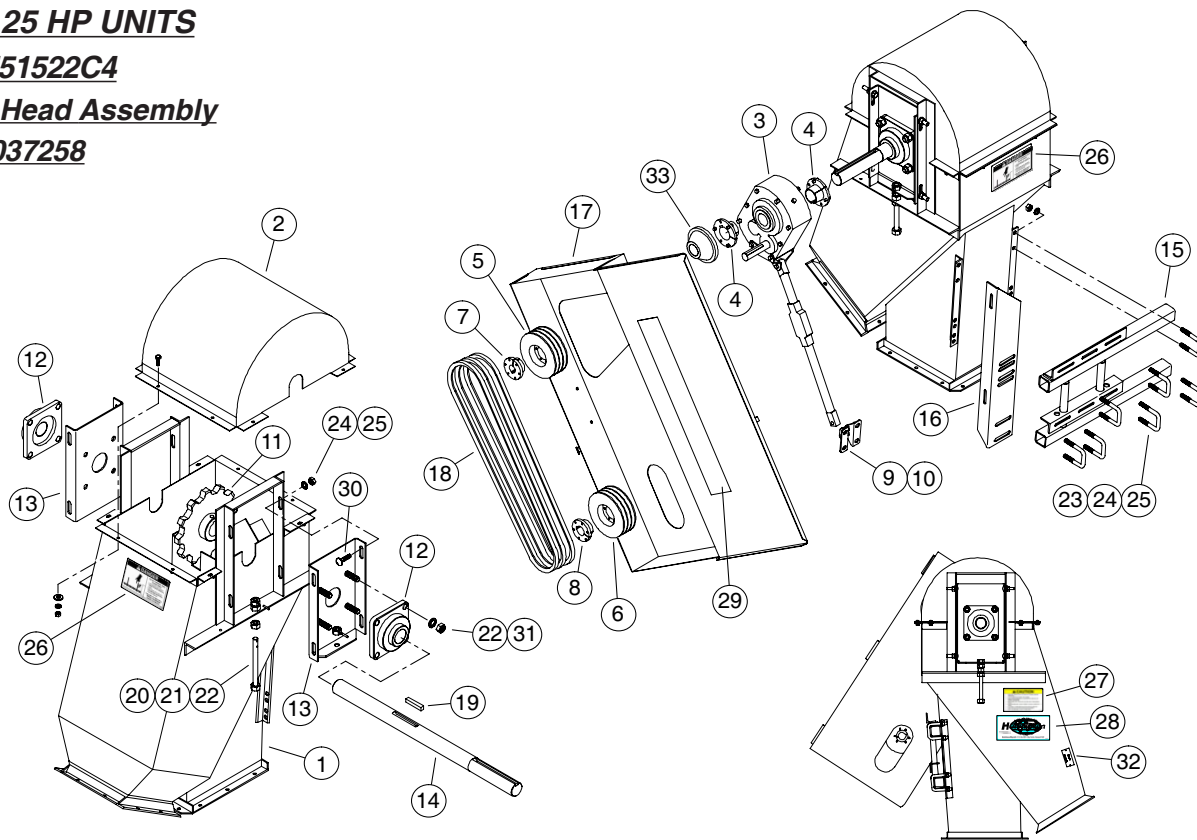

Ref. No.	Part No.	Description	Ref. No.	Part No.	Description
1	1004921	Head, Vertical Drive	17	130288	Belt Guard f/ 25 hp Units
(1)	1004921-AR	Head, Vertical Drive	18	40127	Belt, B-75, 78" long
(1)	1004921-ARS	Head, Vertical Drive	19	4021L1	Key, 1/2" sq. x 2 3/4" long
2	630203	Cover f/ Vertical Head Drive	20	60951	Bolt Take-Up Assembly
3	3004L91	Reducer, TXT 415 (25 hp)	21	31121	Roll Pin, 3/16" x 1" long
4	40673	Reducer Bushing Kit (25 hp)	22	D1170	Nut, 5/8"-10 Non-Lock PLT
5	3269A1	Sheave, QD 3-B 6.8"	23	33240	U-Bolt, 1/2" w/ 2 1/8" spread
6	3269A1	Sheave, QD 3-B 6.8"	24	D1143	Washer, 1/2" Lock PLT
7	3278A1	Bushing, QD SD 1 7/16"	25	D1169	Nut, 1/2"-13 Non-Lock PLT
8	3280A1	Bushing, QD SD 1 7/8"	26	1012872	*Decal, Danger: Do Not Operate...
9	1015236	Bracket, Bolt-On (left)	27	1002301	*Decal, Caution: General Operator
10	1015235	Bracket, Bolt-On (right)	28	1001128	Decal, Hutchinson Globe
11	1005565	Sprocket, 12T 2" bore	29	1001125	Decal, Hutchinson (rectangle)
12	2214C	Bearing, 2" Flange 4-Hole	30	1002243	Bolt, 1/2"-13 x 1 1/2" Carriage
13	61223	Slide Take-Up	31	D1171	Washer, 5/8" Lock PLT
14	550311	Shaft, 2" dia. x 36" long	32	34687	Serial Plate
15	631333	Frame, Motor Mount (25 hp)	33	41884	Cooling Fan
16	553575	Mount, Belt Guard			

The Belt Guard (Item 17) and Cover (Item 2) are attached using:

- 4701-1 5/16"-18 x 3/4" Bolts
- 33023 5/16" Flat Washers
- 33144 5/16" Lock Washers
- 33151 5/16"-18 Non-Lock Nuts

The Complete Assembly can be Obtained, Order Part No. 1037258 (complete assembly includes all items shown)

\*Decals and decal locations may vary.

**MODEL 85 VERTICAL HEAD DRIVE**  
**f/ 15 - 20 HP UNITS**

**M85549C4**

**f/ Head Assembly**

**1040633**

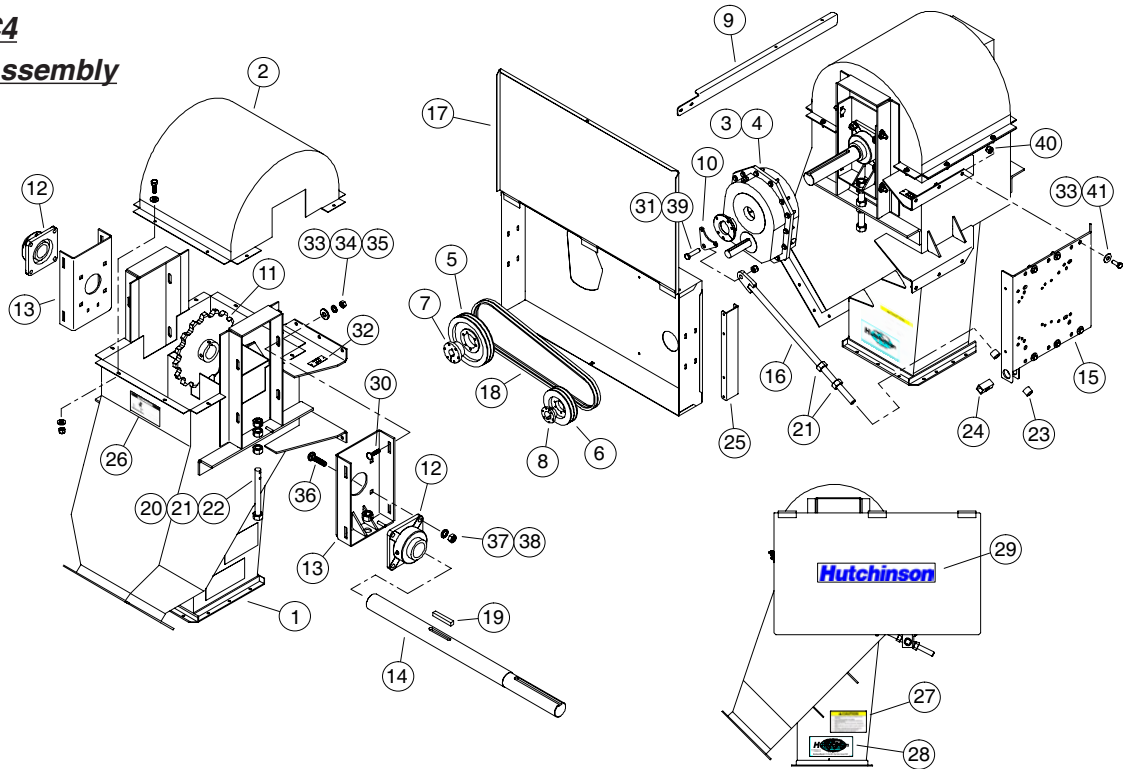

Ref. No.	Part No.	Description
1	1040478	Head, Vertical Drive
(1)	1040478-AR	Head, Vertical Drive
(1)	1040478-ARS	Head, Vertical Drive
2	1040491	Cover f/ Vertical Head Drive
3	1036873	Reducer, TA3203H15
4	1040664	Reducer Bushing Kit
5	3075A1	Sheave, QD 2-B 9.4"
6	3266A1	Sheave, QD 2-B 6.8"
7	3190A1	Bushing, QD SK 1 3/8"
8	3183A1	Bushing, QD SDS 1 5/8"
9	1040594	Bracket, Belt Guard
10	1040665	Mount, Torque Arm
11	420065	Sprocket, 16T 2 7/16" bore
12	3090L1	Bearing, 2 7/16" Flange 4-Hole
13	1040554	Slide Take-Up
14	1040634	Shaft, 2 7/16" dia.
15	1036417	Frame, Motor Mount (15-20 hp)
16	1040666	Tension Rod
17	1040673	Belt Guard f/ 15-20 hp Units
18	1034074	Belt, B-67
19	53060	Key, 5/8" sq. x 3 3/4" long
20	1040573	Bolt Take-Up Assembly

Ref. No.	Part No.	Description
21	D1158	Nut, 1"-8 Non-Lock PLT
22	6328C	Roll Pin, 3/8" x 1 1/2"
23	1030875	Tube, Adjustable Spacer
24	1030876	Retainer, Adjustable Rod
25	1036073	Bracket, Upper Belt Guard
26	1002311	*Decal, Danger: Moving Chain...
27	1002301	*Decal, Caution: General Operator
28	1001128	Decal, Hutchinson Globe
29	1001125	Decal, Hutchinson (rectangle)
30	1002243	Bolt, 1/2"-13 x 1 1/2" Carriage
31	1002234	Bolt, 5/8"-11 x 2 1/2" PLT
32	34687	Serial Plate
33	33025	Washer, 1/2" Flat PLT
34	D1143	Washer, 1/2" Lock PLT
35	D1169	Nut, 1/2"-13 Non-Lock PLT
36	1040563	Bolt, 5/8"-11 x 2" Carriage G5 PLT
37	D1171	Washer, 5/8" Lock PLT
38	D1170	Nut, 5/8"-11 Non-Lock PLT
39	33139	Nut, 5/8"-11 Nylon Lock PLT
40	33138	Nut, 1/2"-13 Nylon Lock
41	33082	Bolt, 1/2"-13 x 1 1/4" G5 PLT

The Belt Guard (Item 17) and Cover (Item 2) are attached using:  
 4701-1 5/16"-18 x 3/4" Bolts; 33023 5/16" Flat Washers  
 33144 5/16" Lock Washers; 33151 5/16"-18 Non-Lock Nuts

The Complete Assembly can be Obtained,  
 Order Part No. 1040633 (complete assembly  
 includes all items shown)

\*Decals and decal locations may vary.

# PARTS LIST

## MODEL 85 VERTICAL HEAD DRIVE

### f/ 25 - 30 HP UNITS

#### M8551C4

#### f/ Head Assembly

#### 1040631

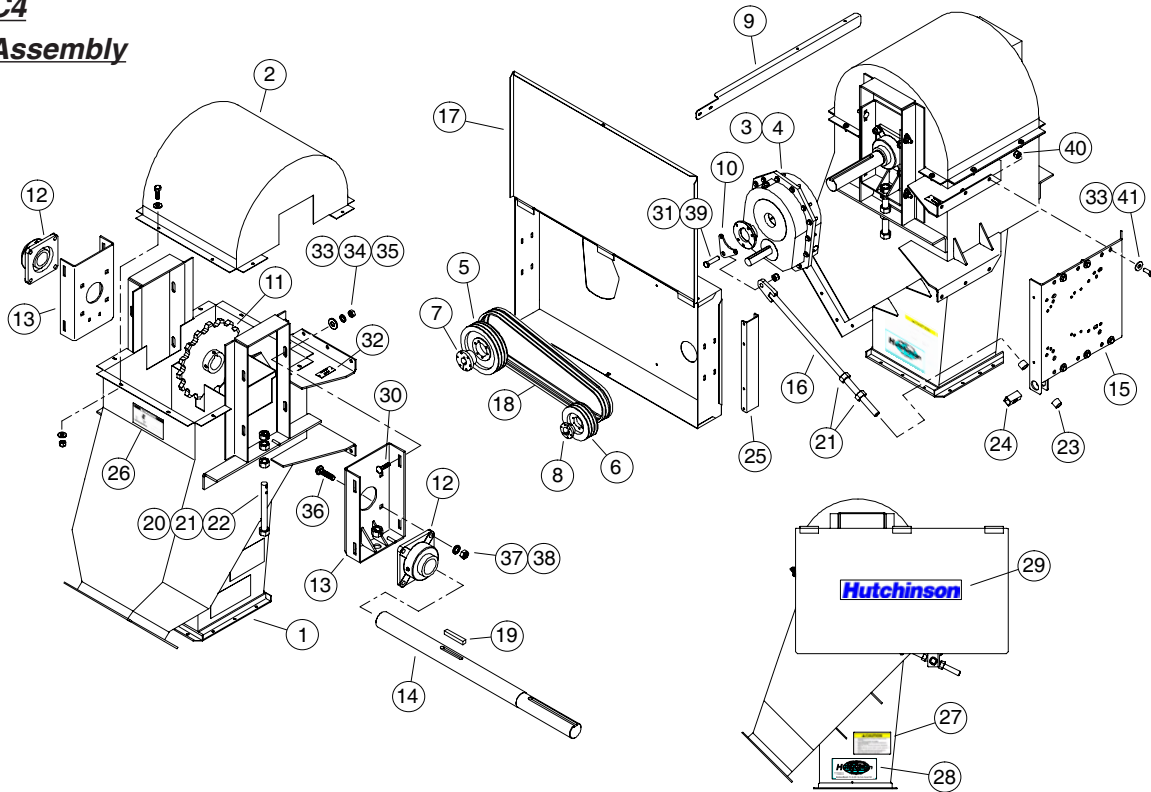

Ref. No.	Part No.	Description
1	1040478	Head, Vertical Drive
(1)	1040478-AR	Head, Vertical Drive
(1)	1040478-ARS	Head, Vertical Drive
2	1040491	Cover f/ Vertical Head Drive
3	1023249	Reducer, TA4207H15
4	1031091	Reducer Bushing Kit
5	3080A1	Sheave, QD 3-B 9.4"
6	3269A1	Sheave, QD 3-B 6.8"
7	3191A1	Bushing, QD SK 1 7/16"
8	3280A1	Bushing, QD SD 1 7/8"
9	1040594	Bracket, Belt Guard
10	1023318	Bracket, Reducer
11	1012624	Sprocket, 16T 3" bore
12	3090L1	Bearing, 2 7/16" Flange 4-Hole
13	1040554	Slide Take-Up
14	1040632	Shaft, 3" dia.
15	1036417	Frame, Motor Mount (15-20 hp)
16	1040699	Tension Rod
17	1040685	Belt Guard f/ 25-30 hp Units
18	40126	Belt, B-71
19	1017181	Key, 3/4" sq. x 4" long
20	1040573	Bolt Take-Up Assembly

Ref. No.	Part No.	Description
21	D1158	Nut, 1"-8 Non-Lock PLT
22	6328C	Roll Pin, 3/8" x 1 1/2"
23	1030875	Tube, Adjustable Spacer
24	1030876	Retainer, Adjustable Rod
25	1036073	Bracket, Upper Belt Guard
26	1002311	*Decal, Danger: Moving Chain...
27	1002301	*Decal, Caution: General Operator
28	1001128	Decal, Hutchinson Globe
29	1001125	Decal, Hutchinson (rectangle)
30	1002243	Bolt, 1/2"-13 x 1 1/2" Carriage
31	33111	Bolt, 3/4"-10 x 2 1/2" PLT
32	34687	Serial Plate
33	33025	Washer, 1/2" Flat PLT
34	D1143	Washer, 1/2" Lock PLT
35	D1169	Nut, 1/2"-13 Non-Lock PLT
36	1040563	Bolt, 5/8"-11 x 2" Carriage G5 PLT
37	D1171	Washer, 5/8" Lock PLT
38	D1170	Nut, 5/8"-11 Non-Lock PLT
39	33140	Nut, 3/4"-10 Nylon Lock PLT
40	33138	Nut, 1/2"-13 Nylon Lock
41	33082	Bolt, 1/2"-13 x 1 1/4" G5 PLT

The Belt Guard (Item 17) and Cover (Item 2) are attached using:  
 4701-1 5/16"-18 x 3/4" Bolts; 33023 5/16" Flat Washers  
 33144 5/16" Lock Washers; 33151 5/16"-18 Non-Lock Nuts

The Complete Assembly can be Obtained,  
 Order Part No. 1040631 (complete assembly  
 includes all items shown)

\*Decals and decal locations may vary.

## MODEL 85 VERTICAL HEAD DRIVE

### f/ 40 HP UNITS

#### M85554C4

#### f/ Head Assembly

#### 1040477

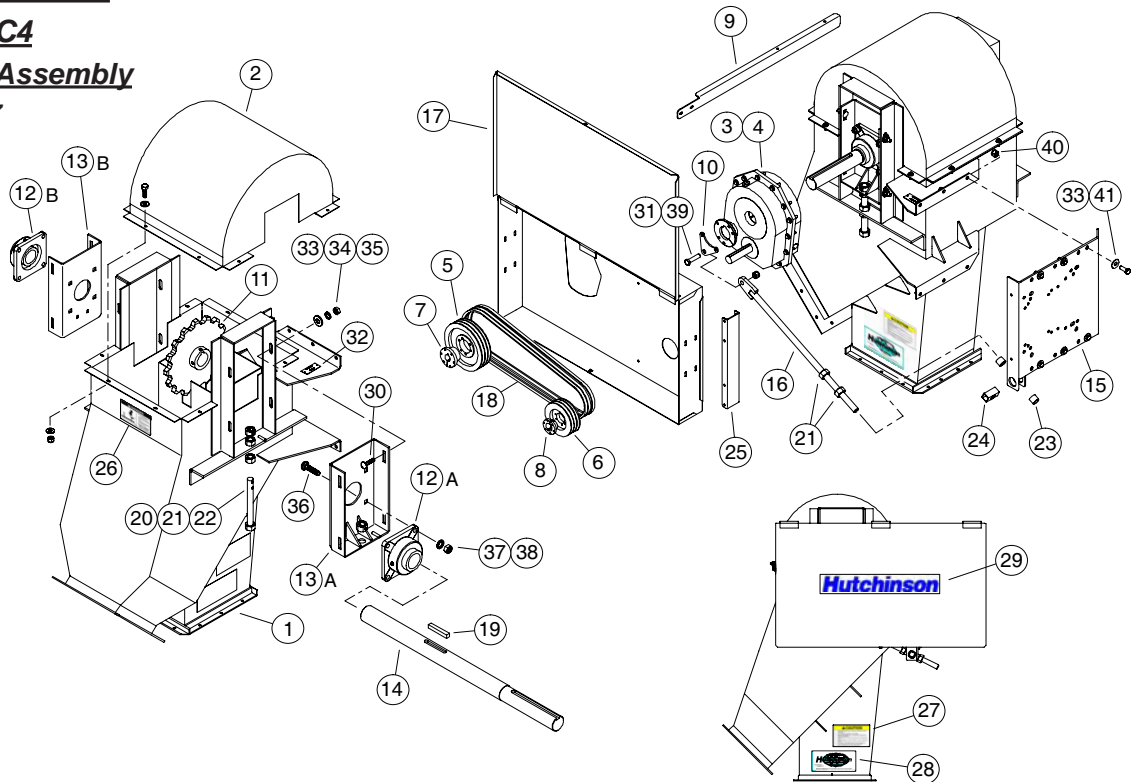

Ref. No.	Part No.	Description
1	1040478	Head, Vertical Drive
(1)	1040478-AR	Head, Vertical Drive
(1)	1040478-ARS	Head, Vertical Drive
2	1040491	Cover f/ Vertical Head Drive
3	1023780	Reducer, TA5215H15
4	1040586	Reducer Bushing Kit
5	3093A1	Sheave, QD 4-B 9.4"
6	1040700	Sheave, Taper Lock 4-B 6.8"
7	3192A1	Bushing, QD SK 1 5/8"
8	1031132	Bushing, Taper Lock 2 1/8"
9	1040594	Bracket, Belt Guard
10	1023795	Reducer Bracket
11	1012624	Sprocket, 16T 3" bore
12A	420075	Bearing, 2 15/16" Flange 4-Hole
12B	3090L1	Bearing, 2 7/16" Flange 4-Hole
13A	1040495	Slide Take-Up, 2 15/16" Brng.
13B	1040554	Slide Take-Up, 2 7/16" Brng.
14	1040574	Shaft, 3" dia.
15	1036417	Frame, Motor Mount (15-20 hp)
16	1030878	Tension Rod
17	1040590	Belt Guard f/ 40 hp Units
18	40126	Belt, B-71
19	1017181	Key, 3/4" sq. x 4" long

Ref. No.	Part No.	Description
20	1040573	Bolt Take-Up Assembly
21	D1158	Nut, 1"-8 Non-Lock PLT
22	6328C	Roll Pin, 3/8" x 1 1/2"
23	1030875	Tube, Adjustable Spacer
24	1030876	Retainer, Adjustable Rod
25	1036073	Bracket, Upper Belt Guard
26	1002311	*Decal, Danger: Moving Chain...
27	1002301	*Decal, Caution: General Operator
28	1001128	Decal, Hutchinson Globe
29	1001125	Decal, Hutchinson (rectangle)
30	1002243	Bolt, 1/2"-13 x 1 1/2" Carriage
31	33111	Bolt, 3/4"-10 x 2 1/2" PLT
32	34687	Serial Plate
33	33025	Washer, 1/2" Flat PLT
34	D1143	Washer, 1/2" Lock PLT
35	D1169	Nut, 1/2"-13 Non-Lock PLT
36	1040563	Bolt, 5/8"-11 x 2" Carriage G5 PLT
37	D1171	Washer, 5/8" Lock PLT
38	D1170	Nut, 5/8"-11 Non-Lock PLT
39	33140	Nut, 3/4"-10 Nylon Lock PLT
40	33138	Nut, 1/2"-13 Nylon Lock
41	33082	Bolt, 1/2"-13 x 1 1/4" G5 PLT

The Belt Guard (Item 17) and Cover (Item 2) are attached using:  
 4701-1 5/16"-18 x 3/4" Bolts; 33023 5/16" Flat Washers  
 33144 5/16" Lock Washers; 33151 5/16"-18 Non-Lock Nuts

The Complete Assembly can be Obtained,  
 Order Part No. 1040477 (complete assembly  
 includes all items shown)

\*Decals and decal locations may vary.

# PARTS LIST

## MODEL 50

### BOOT DRIVE f/ 5 to 20 HP UNITS

M52005C4, M52007C4, M52010C4,

M52015C4, M52020C4

### f/ Boot Assembly

1030729

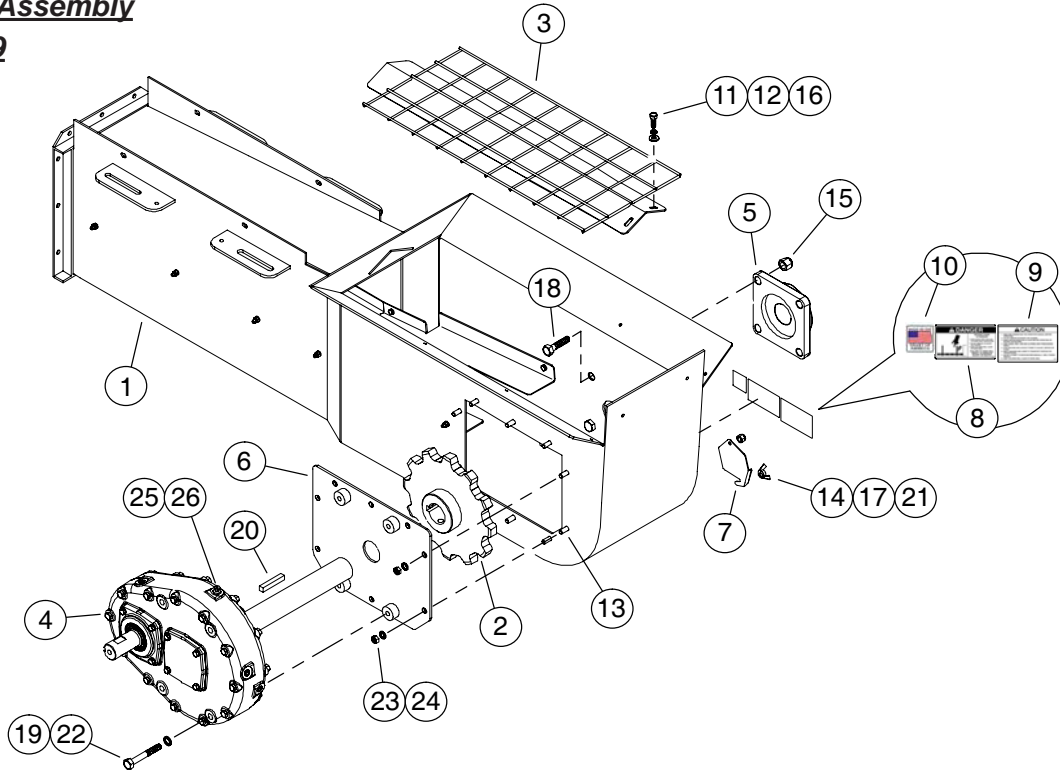

Ref. No.	Part No.	Description	Ref. No.	Part No.	Description
1	1030717	Boot Weldment (M50 Stationary)	13	33060	Bolt, 3/8"-16 x 1" G5 PLT
(1)	1030717-AR	Boot Weldment (M50 Stationary)	14	33135	Nut, 5/16"-18 Nylon Lock PLT
(1)	1030717-ARS	Boot Weldment (M50 Stationary)	15	33139	Nut, 5/8"-11 Nylon Lock PLT
2	1005565	Sprocket, 81C 12T, 2" bore	16	33144	Washer, 5/16" Lock PLT
3	1028137	Screen, Shield	17	33157	Nut, 5/16"-18 Wing PLT
4	1028204-1	Gearbox 4:1 Reduction	18	33244	Bolt, 5/8"-11 x 2" G5 PLT
5	2214C	Bearing, 2" 4-Hole Flange	19	33384	Bolt, 1/2"-13 x 4 1/2" PLT
6	1028250	Plate, Cover (gearbox mount)	20	4021L1	Key, 1/2" sq. x 2 3/4" long
7	1004738	Door, Hopper Inlet	21	4701-1	Bolt, 5/16"-18 x 3/4" G5 PLT
8	1002311	Decal, Danger: Moving Chain...	22	D1143	Washer, 1/2" Lock PLT
9	1001973	Decal, Caution: General Operator	23	D1149	Nut, 3/8"-16 Non-Lock PLT
10	1041833	Decal, USA Flag	24	D1150	Washer, 3/8" Lock PLT
11	33023	Washer, 5/16" Flat PLT	25	1030211	Bushing, Reducer (3/8" to 1/8" NPT)
12	33046	Bolt, 5/16"-18 x 1" G5 PLT	26	1015290	Vent, Relief, PR 1-5 lb. (1/8" NPT)

# PARTS LIST

**MODEL 50**

**BOOT DRIVE f/ 5 to 20 HP UNITS**

**M52005C4, M52007C4, M52010C4,**

**M52015C4, M52020C4**

**f/ Boot Assembly 1030729 (con't.)**

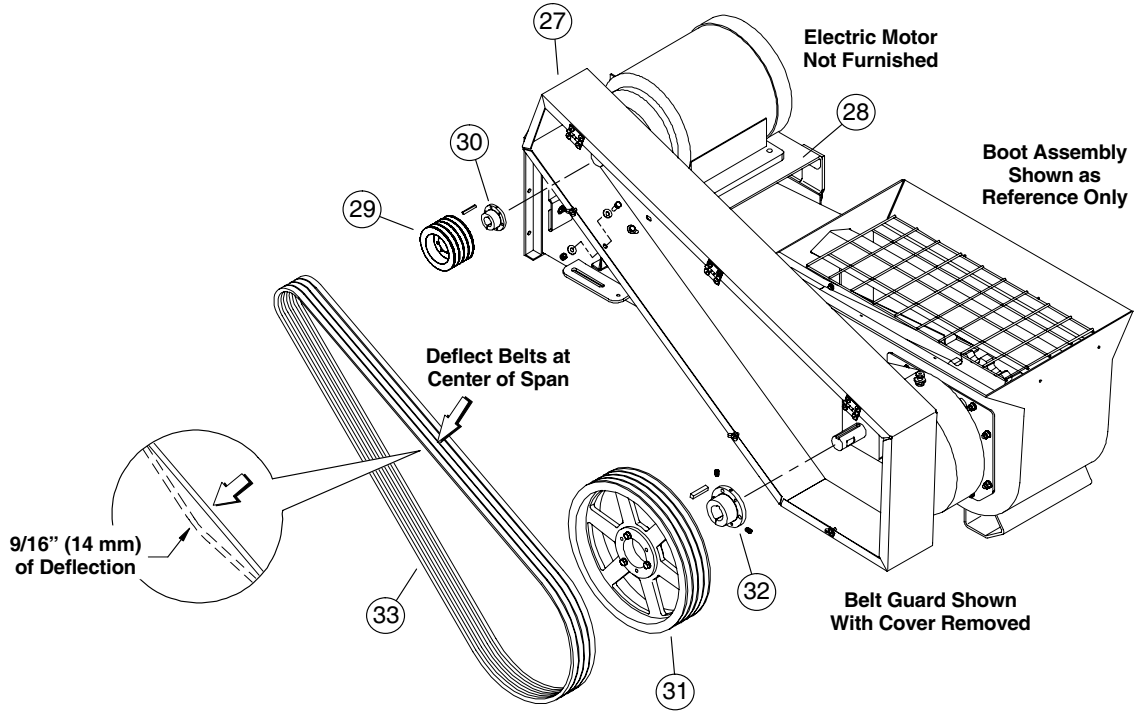

Ref. No.	Part No.	Description	Ref. No.	Part No.	Description
27	1028326	Belt Guard (M50 Boot Drive)	31	40646	Sheave, Driven 2B 15" f/ 5 & 7 1/2" hp
28	1030641	Plate, Motor Mount	(31)	40652	Sheave, Driven 3B 15.4" f/ 10 hp
29	1024515	Sheave, Motor 2B 4.2" (f/ 5 & 7.5 hp)	(31)	3092A1	Sheave, Driven 4B 15.4" f/ 15 hp
(29)	1024516	Sheave, Motor 3B 4.2" (f/ 10 hp)	(31)	3254A1	Sheave, Driven 5B 15.4" f/ 20 hp
(29)	3248A1	Sheave, Motor 4B 4.2" (f/ 15 hp)	32	3295A1	Bushing, Driven Sheave SK 1 1/2" f/ 5, 7 1/2 & 10 hp
(29)	1030755	Sheave, Motor 5B 4.2" (f/ 20 hp)	(32)	3073A1	Bushing, Driven Sheave SF f/ 15 & 20 hp
30	3079A1	Bushing, Motor Sheave SH 1 1/8" f/ 5 hp	33	40134	Belt, B105
(30)	3086A1	Bushing, Motor Sheave SH 1 3/8" f/ 7 1/2 & 10 hp			
(30)	3089A1	Bushing, Motor Sheave SD 1 5/8" f/ 15 & 20 hp			

# PARTS LIST

## MODEL 85

### BOOT DRIVE f/ 25 to 40 HP UNITS

#### M85025C4, M85030C4, M85040C4

#### f/ Boot Assembly 1033241

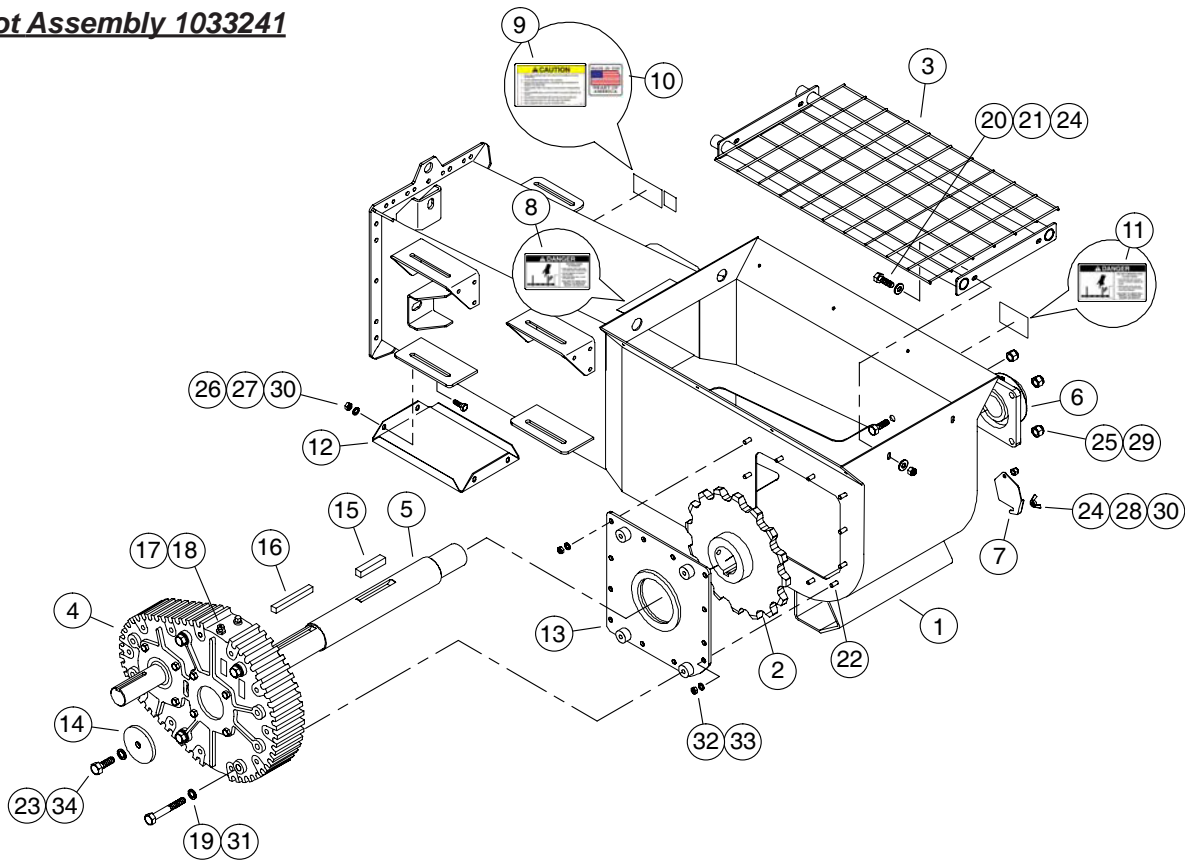

Ref. No.	Part No.	Description	Ref. No.	Part No.	Description
1	1033240	Boot Weldment (M85 Stationary)	17	1015290	Vent, Relief, PR 1-5 lb. (1/8" NPT)
(1)	1033240-AR	Boot Weldment (M85 Stationary)	18	1030211	Bushing, Reducer 3/8" to 1/8" NPT
(1)	1033240-ARS	Boot Weldment (M85 Stationary)	19	1031908	Bolt, 1/2"-13 x 6" G5 PLT
2	1012624	Sprocket, 81C 16T, 3" bore	20	33023	Washer, 5/16" Flat PLT
3	1032628	Screen, Shield	21	33046	Bolt, 5/16"-18 x 1" G5 PLT
4	1031082-1	Gearbox 4:1 Reduction	22	33060	Bolt, 3/8"-16 x 1" G5 PLT
5	1032608	Shaft, Inlet Boot, 3" dia.	23	33110	Bolt, 3/4"-10 x 2" G5 PLT
6	3090L1	Bearing, 2 7/16" 4-Hole Flange	24	33135	Nut, 5/16"-18 Nylon Lock PLT
7	1004738	Door, Hopper Inlet	25	33139	Nut, 5/8"-11 Nylon Lock PLT
8	1002311	Decal, Danger: Moving Chain...	26	33144	Washer, 5/16" Lock PLT
9	1001973	Decal, Caution: General Operator	27	33151	Nut, 5/16"-18 Non-Lock PLT
10	1041833	Decal, USA Flag	28	33157	Nut, 5/16"-18 Wing PLT
11	1012872	Decal, Danger: Do Not Operate...	29	33244	Bolt, 5/8"-11 x 2" G5 PLT
12	1005798	Door, Inlet Clean-out	30	4701-1	Bolt, 5/16"-18 x 3/4" G5 PLT
13	1032607	Mount, f/ Reducer Gearbox	31	D1143	Washer, 1/2" Lock PLT
14	1031922	Washer, 3 1/2" O.D. x 13/16" I.D.	32	D1149	Nut, 3/8"-16 Non-Lock PLT
15	553512	Key, 3/4" sq. x 3 1/2" long	33	D1150	Washer, 3/8" Lock PLT
16	1031921	Key, 5/8" sq. x 5 1/4" long	34	D1153	Washer, 3/4" Lock PLT

**MODEL 85**

**BOOT DRIVE f/ 25 to 40 HP UNITS**

**M85025C4, M85030C4, M85040C4**

**f/ Boot Assembly 1033241 (con't.)**

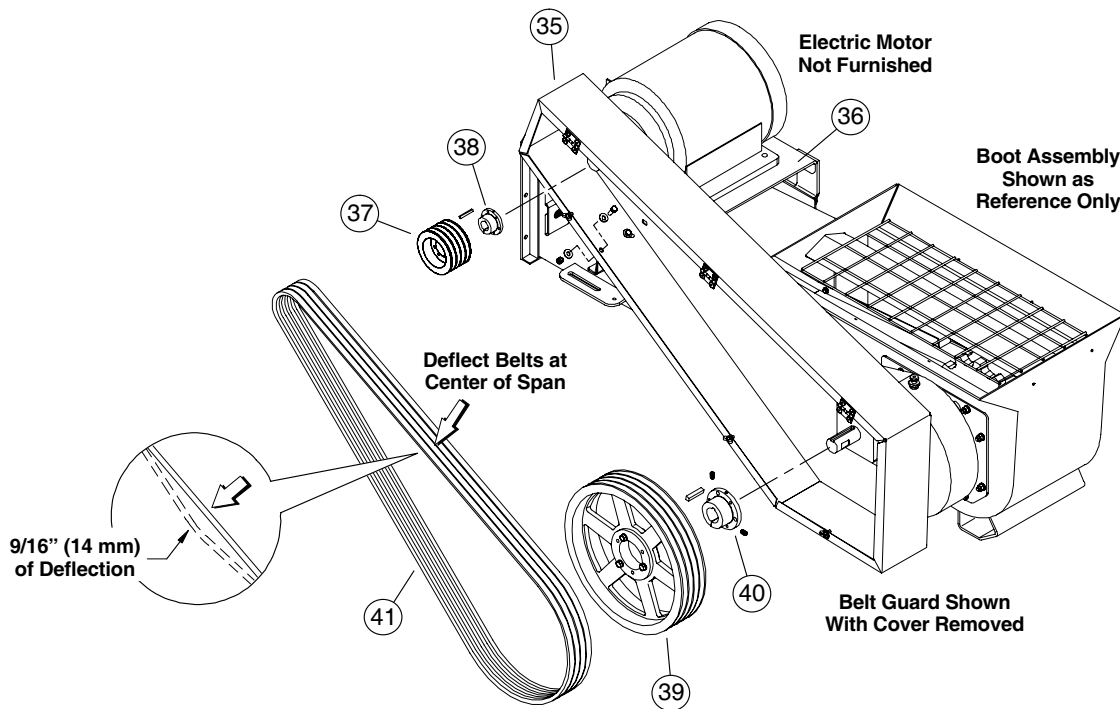

Ref. No.	Part No.	Description	Ref. No.	Part No.	Description
35	1033018	Belt Guard (M85 Boot Drive)	39	40874	Sheave, Driven 3B 20" f/ 25 hp
36	1032875	Plate, Motor Mount	(39)	40649	Sheave, Driven 4B 20" f/ 30 hp
37	3276A1	Sheave, Motor 3B 5.4" (f/ 25 hp)	(39)	40084	Sheave, Driven 6B 20" f/ 30 hp
(37)	420077	Sheave, Motor 4B 5.4" (f/ 30 hp)	40	1030416	Bushing, Driven Sheave QD SF 1 3/4" f/ 25 & 30 hp
(37)	1033325	Sheave, Motor 6B 5.4" (f/ 40 hp)	(40)	1029051	Bushing, Driven Sheave QD E 1 3/4" f/ 40 hp
38	3280A1	Bushing, Motor Sheave QD SD 1 7/8" f/ 25 & 30 hp	41	40136	Belt, B112
(38)	3281A1	Bushing, Motor Sheave QD SK 2 1/8" f/ 40 hp			

# PARTS LIST

## MODEL M50 & M85

### 30° CORNERS

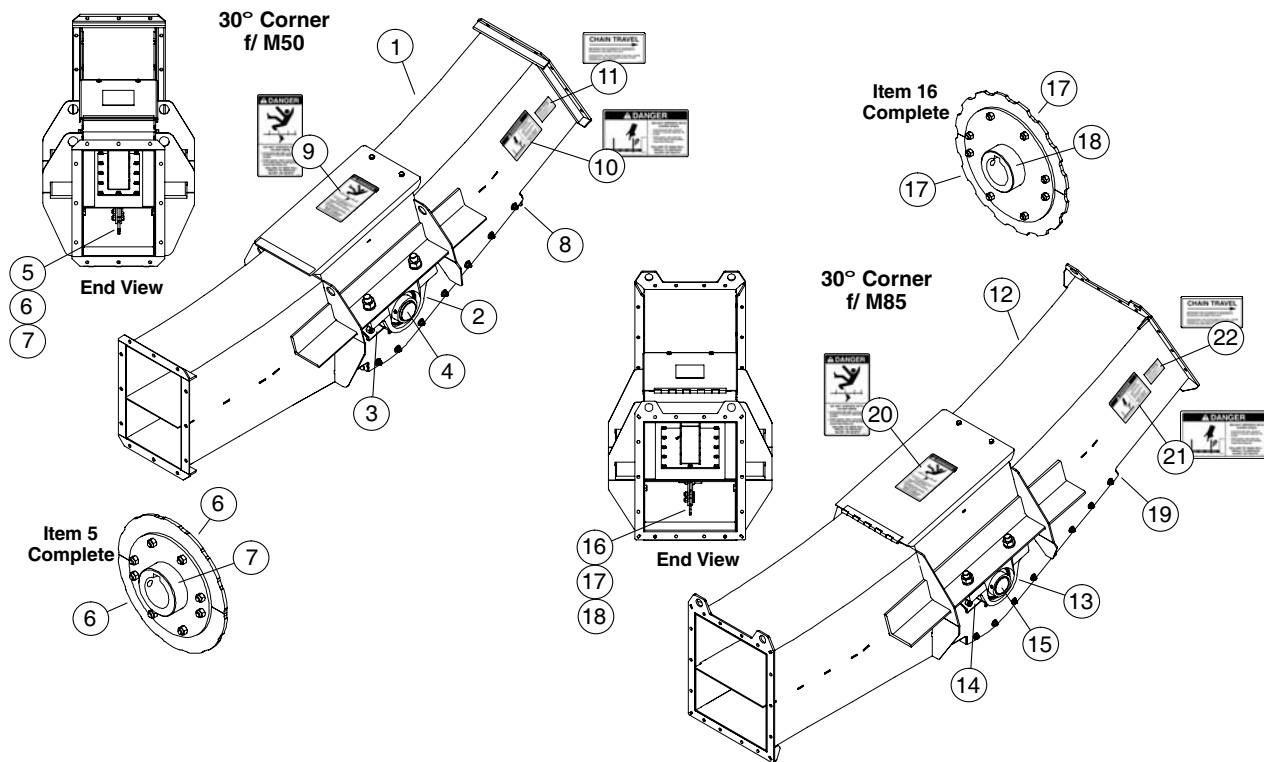

#### M50 Models M50425C5

Ref. No.	Part No.	Description
1	1045983	Corner Weldment, 30° (M50)
2	1023254	Bearing, Pillow Block, 2 7/16"
3	1043264	Seal, f/ 2 7/16" Shaft
4	1043894	Shaft, 2 7/16" x 17 3/4"
5	1044579	Sprocket Assembly, Complete
6	1044577	•Plate, Segmented Tooth
7	1044578	•Hub f/ Segmented Plate
8	1045993	Inspection Cover f/ 30° Corner
9	1002310	Decal, Danger: Cover Missing
10	1012872	Decal, Danger: Do Not Operate
11	34221	Decal, Chain Travel

#### M85 Models M85425C5

Ref. No.	Part No.	Description
12	1045964	Corner Weldment, 30° (M85)
13	1023254	Bearing, Pillow Block, 2 7/16"
14	1043264	Seal, f/ 2 7/16" Shaft
15	1043263	Shaft, 2 7/16" x 21 1/4"
16	1044553	Sprocket Assembly, Complete
17	1044551	•Plate, Segmented Tooth
18	1044552	•Hub f/ Segmented Plate
19	1045976	Inspection Cover f/ 30° Corner
20	1002310	Decal, Danger: Cover Missing
21	1012872	Decal, Danger: Do Not Operate
22	34221	Decal, Chain Travel

•Indented Parts Names Indicate these Parts are Included in the Previous Assembly.

## MODEL M50 & M85

### 45° CORNERS

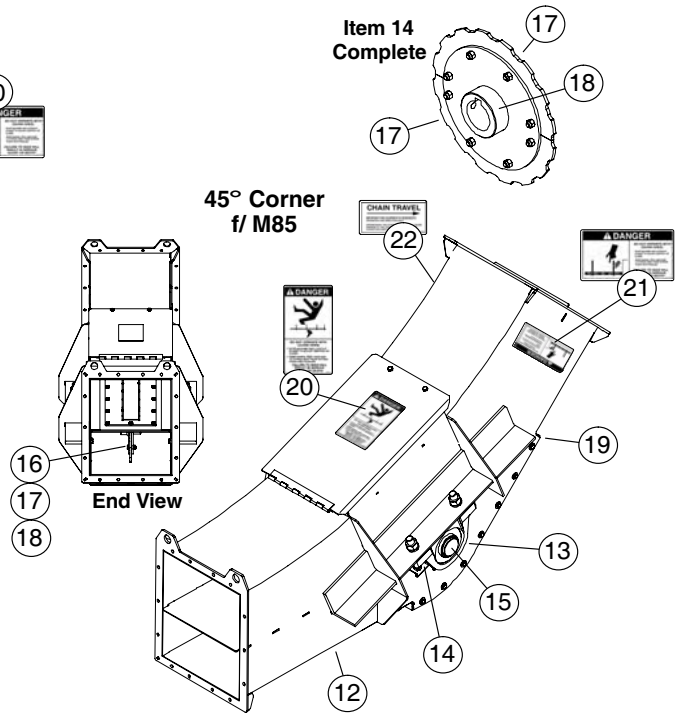
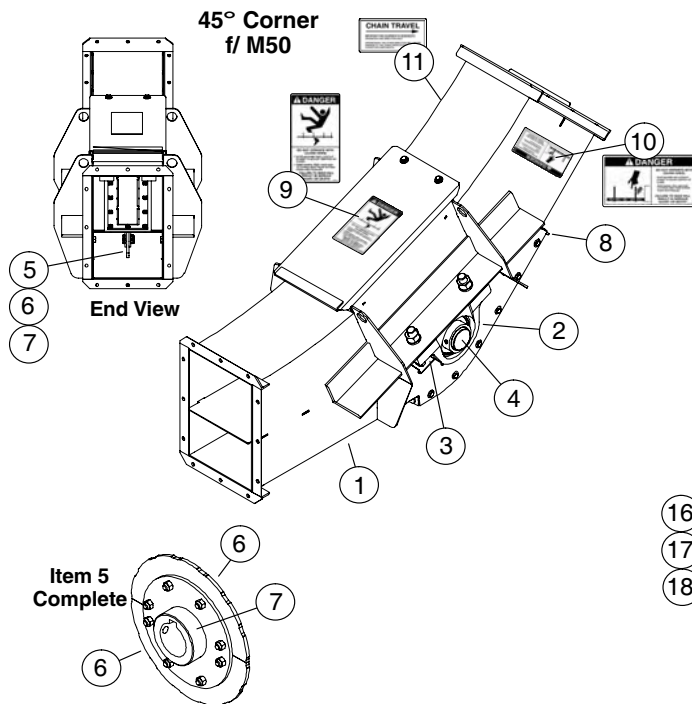

#### M50 Models M50426C5

Ref. No.	Part No.	Description
1	1043939	Corner Weldment, 45° (M50)
2	1023254	Bearing, Pillow Block, 2 7/16"
3	1043264	Seal, f/ 2 7/16" Shaft
4	1043894	Shaft, 2 7/16" x 17 3/4"
5	1044579	Sprocket Assembly, Complete
6	1044577	•Plate, Segmented Tooth
7	1044578	•Hub f/ Segmented Plate
8	1043955	Inspection Cover f/ 45° Corner
9	1002310	Decal, Danger: Cover Missing
10	1012872	Decal, Danger: Do Not Operate
11	34221	Decal, Chain Travel

#### M85 Models M85426C5

Ref. No.	Part No.	Description
12	1043604	Corner Weldment, 45° (M85)
13	1023254	Bearing, Pillow Block, 2 7/16"
14	1043264	Seal, f/ 2 7/16" Shaft
15	1043263	Shaft, 2 7/16" x 21 1/4"
16	1044553	Sprocket Assembly, Complete
17	1044551	•Plate, Segmented Tooth
18	1044552	•Hub f/ Segmented Plate
19	1043714	Inspection Cover f/ 45° Corner
20	1002310	Decal, Danger: Cover Missing
21	1012872	Decal, Danger: Do Not Operate
22	34221	Decal, Chain Travel

• Indented Parts Names Indicate these Parts are Included in the Previous Assembly.

# PARTS LIST

## MODEL M50 & M85

### 90° CORNERS

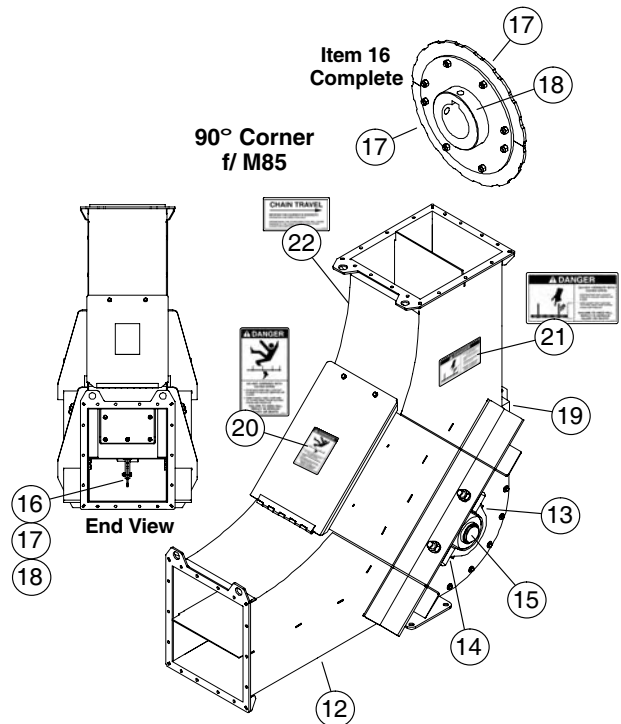
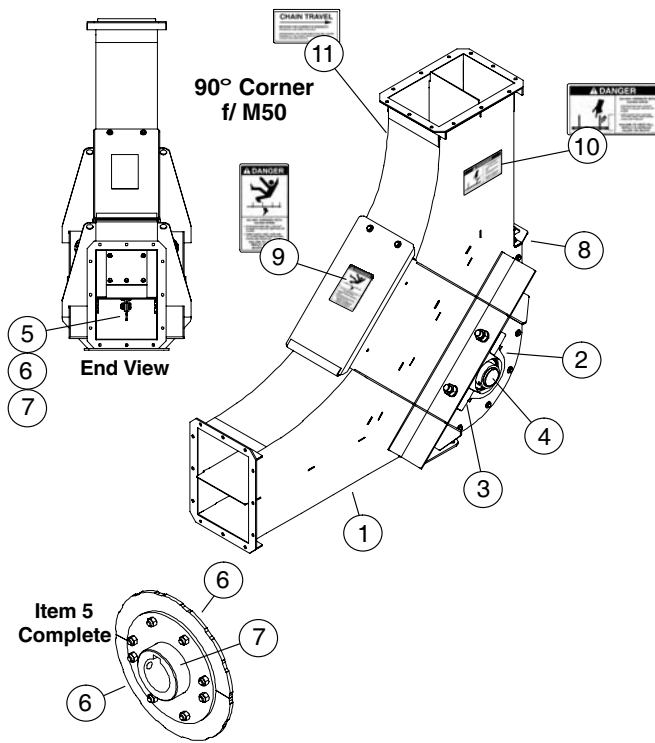

#### M50 Models M50427C5

Ref. No.	Part No.	Description
1	1043876	Corner Weldment, 90° (M50)
2	1023254	Bearing, Pillow Block, 2 7/16"
3	1043264	Seal, f/ 2 7/16" Shaft
4	1043894	Shaft, 2 7/16" x 17 3/4"
5	1044579	Sprocket Assembly, Complete
6	1044577	•Plate, Segmented Tooth
7	1044578	•Hub f/ Segmented Plate
8	1043892	Inspection Cover f/ 90° Corner
9	1002310	Decal, Danger: Cover Missing
10	1012872	Decal, Danger: Do Not Operate
11	34221	Decal, Chain Travel

#### M85 Models M85427C5

Ref. No.	Part No.	Description
12	1043250	Corner Weldment, 90° (M85)
13	1023254	Bearing, Pillow Block, 2 7/16"
14	1043264	Seal, f/ 2 7/16" Shaft
15	1043999	Shaft, 3 7/16" x 21 1/4"
16	1044575	Sprocket Assembly, Complete
17	1044573	•Plate, Segmented Tooth
18	1044574	•Hub f/ Segmented Plate
19	1043261	Inspection Cover f/ 90° Corner
20	1002310	Decal, Danger: Cover Missing
21	1012872	Decal, Danger: Do Not Operate
22	34221	Decal, Chain Travel

•Indented Parts Names Indicate these Parts are Included in the Previous Assembly.

## MODEL 50 CENTER BIN WELL (BYPASS STYLE)

**M50367C4**

**f/ Well Assembly 1001383**

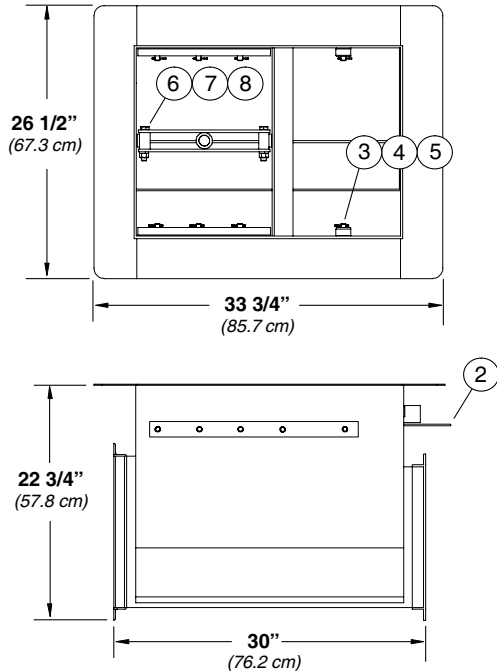

Ref. No.	Part No.	Description
1	1001390	Bin Well, Center f/ Model 50
2	52446	Gate, Bin Well Center
3	51867	Wheel, Nylon
4	33025	Washer, 1/2" Flat
5	33161	Cotter Pin, 1/8" x 1" long
6	D1143	Washer, 1/2" Lock
7	D1169	Nut, 1/2"-13 Non-Lock
8	33091	Bolt, 1/2"-13 x 3"
*	52447	Cover, Bin Well f/ M50
* Not Shown		

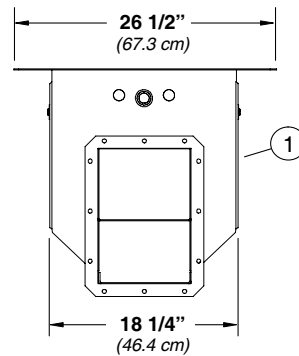

## MODEL 50 INTERMEDIATE BIN WELL (BYPASS STYLE)

**M50368C4**

**f/ Well Assmby 1001384**

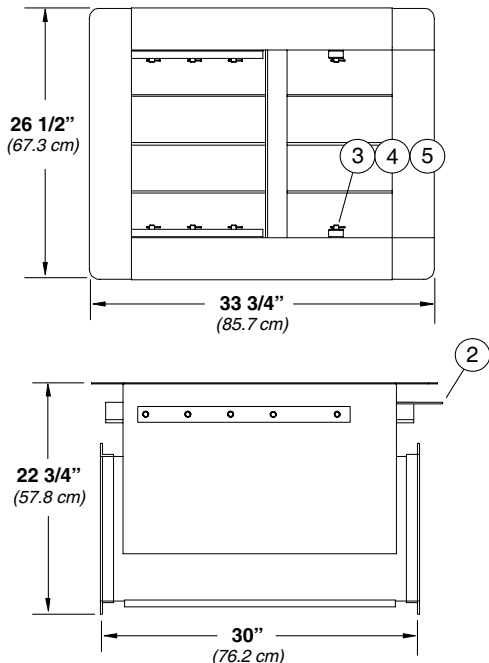

Ref. No.	Part No.	Description
1	1001391	Bin Well, Intermediate f/ M50
2	52445	Gate, Bin Well Intermediate
3	51867	Wheel, Nylon
4	33025	Washer, 1/2" Flat
5	33161	Cotter pin, 1/8" x 1" long
*	52447	Cover, Bin Well f/ M50
* Not Shown		

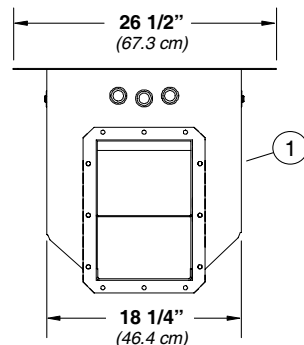

# PARTS LIST

## MODEL 85 CENTER BIN WELL (BYPASS STYLE)

M85383C4

f/ Well Assmly 1001385

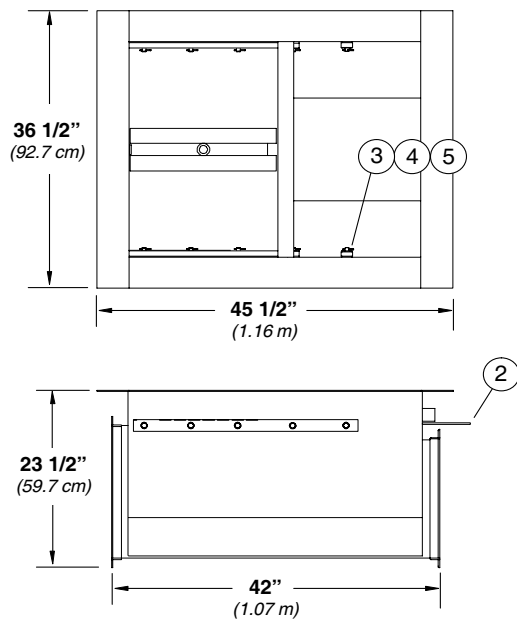

Ref. No.	Part No.	Description
1	1001390	Bin Well, Center f/ Model 85
2	52446	Gate, Bin Well Center
3	51867	Wheel, Nylon
4	33025	Washer, 1/2" Flat
5	33161	Cotter Pin, 1/8" x 1" long
*	54268	Cover, Bin Well, cntr well
		* Not Shown

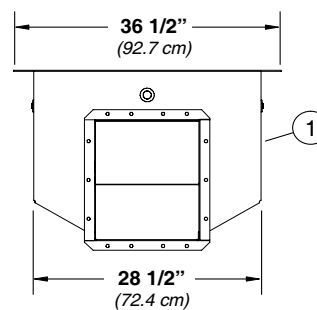

## MODEL 85 INTERMEDIATE BIN WELL (BYPASS STYLE)

M85384C4

f/ Well Assembly 1001386

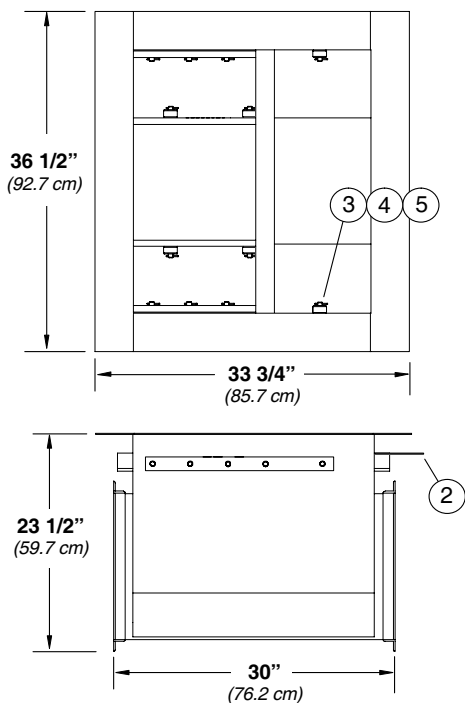

Ref. No.	Part No.	Description
1	1001381	Bin Well, Intermediate f/ M85
2	53991	Gate, Bin Well Intermediate
3	51867	Wheel, Nylon
4	33025	Washer, 1/2" Flat
5	33161	Cotter pin, 1/8" x 1" long
*	54207	Cover, Bin Well, intr. well
		* Not Shown

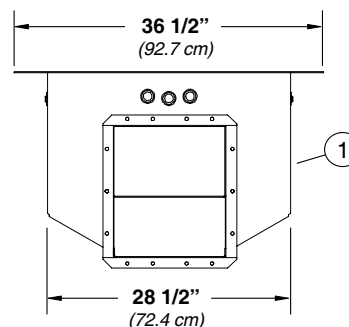

**MODEL 50 & MODEL 85**  
**RACK & PINION CONTROL**  
**(f/ BYPASS STYLE WELLS)**  
**M50369, Model 50**  
**M85385, Model 85**

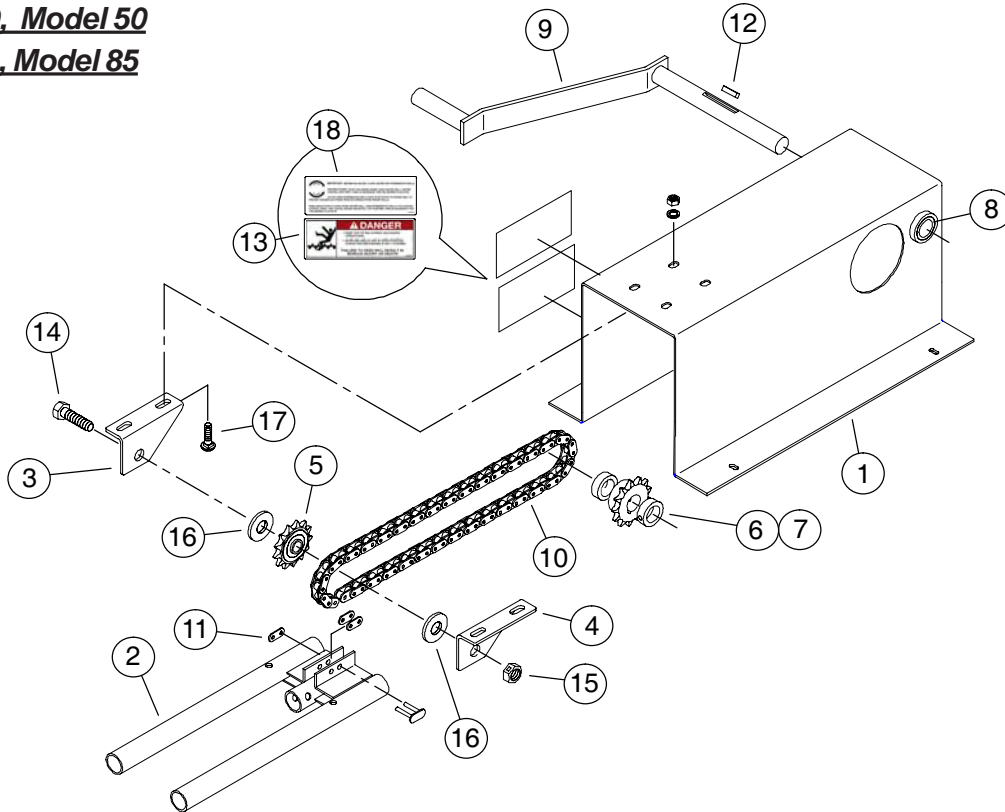

All Items Listed are used with Both the Model 50 & Model 85 Units unless Otherwise Noted.

The Complete Rack & Pinion Control Assembly can be Obtained. Order Part No.

10788 f/ Model 50

12043 f/ Model 85

(complete assembly includes all items listed)

Ref. No.	Part No.	Description	Ref. No.	Part No.	Description
1	61851	Housing Weldment f/ Model 50	(9)	62609	Handle, R&P Control f/ Model 85
(1)	62608	Housing Weldment f/ Model 85	10	52362	Chain, RC-50 50 Pitch w/ Link
2	61703	Tube Control Weldment	11	40023	Connecting Link, f/ RC-50 Chain
3	52327	Bracket, Idler Sprocket (left)	12	4020A1	Key, 1/4" sq. x 1" long
4	52326	Bracket, Idler Sprocket (right)	13	1002305	Decal, Danger: Bin Well Control
5	6821P	Sprocket, Idler, 50B 13T, 5/8" bore	14	D1144	Bolt, 5/8"-11 x 2" G5 PLT
6	5204H	Sprocket, 50B 13T, 1" bore	15	33139	Nut, 5/8"-11 Nylon Lock PLT
7	3324A1	Lock Collar, 1"	16	33026	Washer, 5/8" Flat PLT
8	6303D	Bushing, Bronze, 1 3/8" O.D. x 1 1/32" I.D. x 1" long	17	1002247	Bolt, 5/8"-11 x 3/4" Carriage G5 PLT
9	61687	Handle, R&P Control f/ Model 50	18	1006947	Decal, R&P Control Wells

# PARTS LIST

## UNIVERSAL CENTER WELL

D09605-S f/ M50 MODELS

J3280A-S f/ M85 MODELS

Complete Well Assembly: Part No. 130158

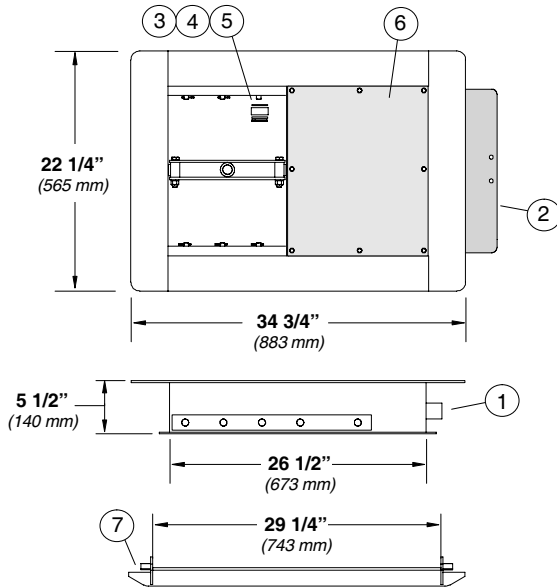

Ref. No.	Part No.	Description
1	631107	Bin Well, Universal Center
2	1026700	Gate, Center Bin Well
3	51867	Wheel, Nylon
4	33025	Washer, 1/2" Flat PLT
5	33161	Cotter Pin, 1/8" x 1" long
6	52308	Cover f/ Bin Well
7	1044313	Screed Adapter f/ M50
(7)	1044342	Screed Adapter f/ M85

## UNIVERSAL INTERMEDIATE WELL

D09604-S f/ M50 MODELS

J3281A-S f/ M85 MODELS

Complete Well Assembly: Part No. 130159

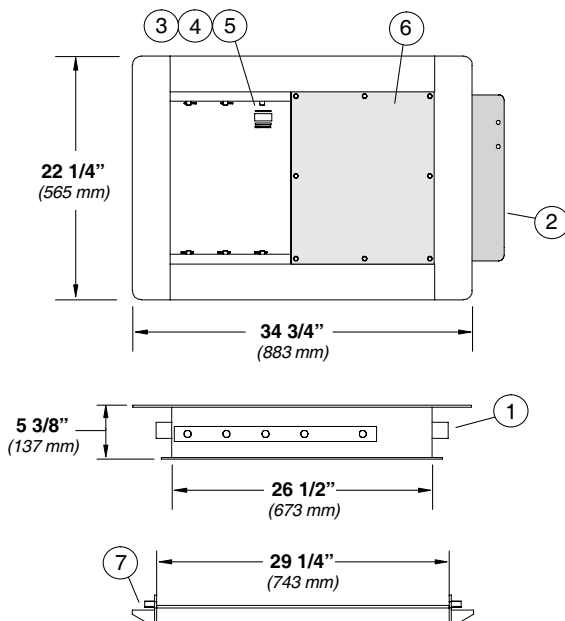

Ref. No.	Part No.	Description
1	631108	Bin Well, Universal Intermediate
2	1026701	Gate, Intermediate Bin Well
3	51867	Wheel, Nylon
4	33025	Washer, 1/2" Flat PLT
5	33161	Cotter Pin, 1/8" x 1" long
6	52308	Cover f/ Bin Well
7	1044313	Screed Adapter f/ M50
(7)	1044342	Screed Adapter f/ M85

## RACK & PINION f/ UNIVERSAL WELLS

D09606 f/ M50 MODELS

D13606 f/ M85 MODELS

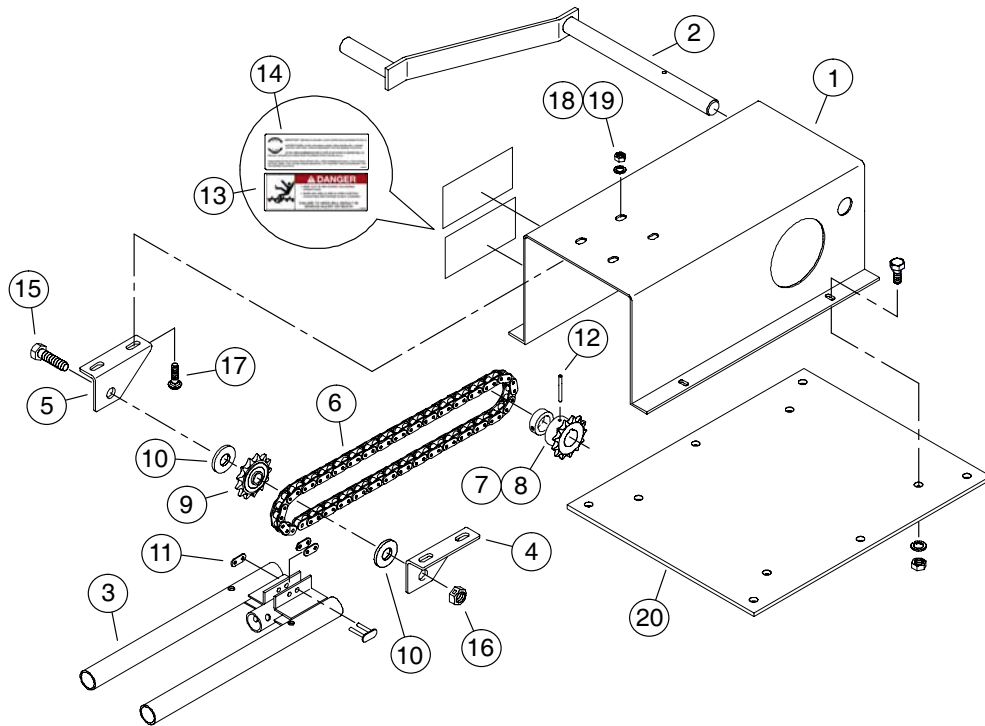

**Complete Rack & Pinion Assembly:  
Part No. 130160 f/ M50 & M85 Models**

**All Items shown are used with both the  
M50 & M85 Models unless otherwise noted.**

Ref. No.	Part No.	Description	Ref. No.	Part No.	Description
1	631109	Housing, Rack & Pinion	12	33243	Roll Pin, 5/16" x 1 3/4" long
2	631110	Handle f/ Rack & Pinion	13	1002305	Decal, Danger: Bin Well Control
3	61703	Tube, Control	14	1006947	Decal, Rack & Pinion Instruction
4	52326	Bracket, Idler Sprocket (right)	15	33244	Bolt, 5/8-11 x 2" G5 PLT
5	52327	Bracket, Idler Sprocket (left)	16	1005111	Nut, 5/8-11 Side Depress Lock
6	52362	Chain, RC50, 50 pitch	17	1001631	Bolt, 3/8-16 x 1" Carriage G5 PLT
7	420080	Sprocket, #50 13T, 1" bore	18	D1150	Washer, 3/8" Lock PLT
8	3324A1	Collar, 1" Lock	19	D1149	Nut, 3/8-16 Non-Lock PLT
9	6821P	Sprocket w/ Bearing, #50 13T	20	552884	Plate, Mounting Adapter, f/ M50
10	33026	Washer, 5/8" Flat	(20)	553000	Plate, Mounting Adapter, f/ M85
11	40023	Link, #50 Double Connecting			

# PARTS LIST

## MODEL 50 & MODEL 85 FLOW THRU HOPPER

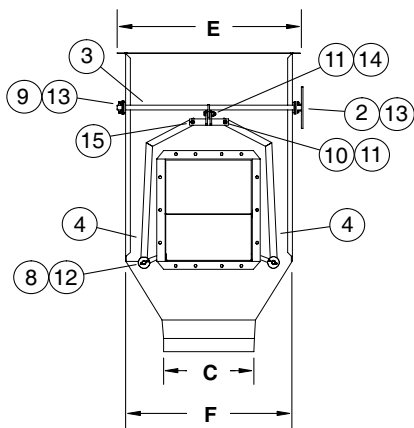
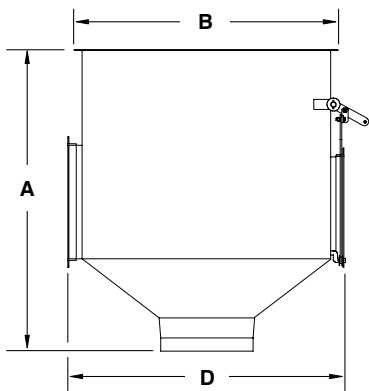

Flow Thru Hopper Dimensions

	A	B	C	D
<b>Model 50</b>	34 1/8" (86.7 cm)	28" (71.1 cm)	10" (25.4 cm)	30" (76.2 cm)
<b>Model 85</b>	45 5/16" (1.15 m)	40" (1.02 m)	14 1/4" (36.2 cm)	42" (1.07 m)

	E	F
<b>Model 50</b>	21 3/4" (55.2 cm)	19 1/4" (48.9 cm)
<b>Model 85</b>	27 3/4" (70.5 cm)	25 1/4" (64.1 cm)

"C" is Outside Diameter of Round Opening

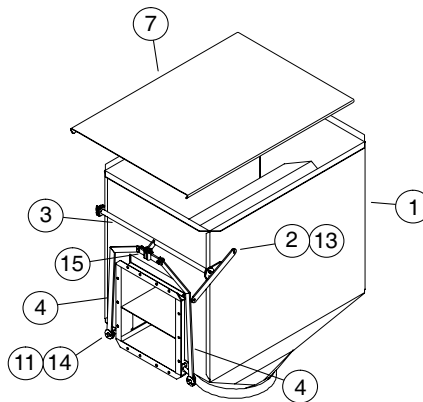

All Items Listed are used with Both the Model 50 & Model 85 Units unless Otherwise Noted.

Ref. No.	Part No.	Description	Ref. No.	Part No.	Description
1	1001394	Hopper, Flow Thru Wldmnt (M50)	(6)	630190*	Gate f/ Flow Thru Hopper (M50)
(1)	1001394-AR	Hopper, Flow Thru Wldmnt (M50)	(6)	630195*	Gate f/ Flow Thru Hopper (M85)
(1)	1001394-ARS	Hopper, Flow Thru Wldmnt (M50)	7	53978	Cover f/ Flow Thru Hopper (M50)
(1)	1001395	Hopper, Flow Thru Wldmnt (M85)	(7)	53986	Cover f/ Flow Thru Hopper (M85)
(1)	1001395-AR	Hopper, Flow Thru Wldmnt (M85)	8	33026	Washer, 5/8" Flat PLT
(1)	1001395-AR	Hopper, Flow Thru Wldmnt (M85)	9	33027	Washer, 3/4" Flat PLT
2	630185	Handle, Control f/ Flow Thru Hppr.	10	33060	Bolt, 3/8"-16 x 1" G5 PLT
3	630186	Shaft, Control Weldment (M50)	11	33136	Nut, 3/8"-16 Nylon Lock PLT
(3)	630193	Shaft, Control Weldment (M85)	12	33161	Cotter Pin, 1/8" x 1" long
4	630188	Bar, Connecting Control (M50)	13	33243	Pin, Roll, 5/16" x 1 3/4" long
(4)	630192	Bar, Connecting Control (M85)	14	33310	Bolt, 3/8"-16 x 1 1/2" G5 PLT
5	630189*	Gate f/ Flow Thru Hopper (M50)	15	630187	Arm, Control Pull
(5)	630194*	Gate f/ Flow Thru Hopper (M85)			

\* Not Shown

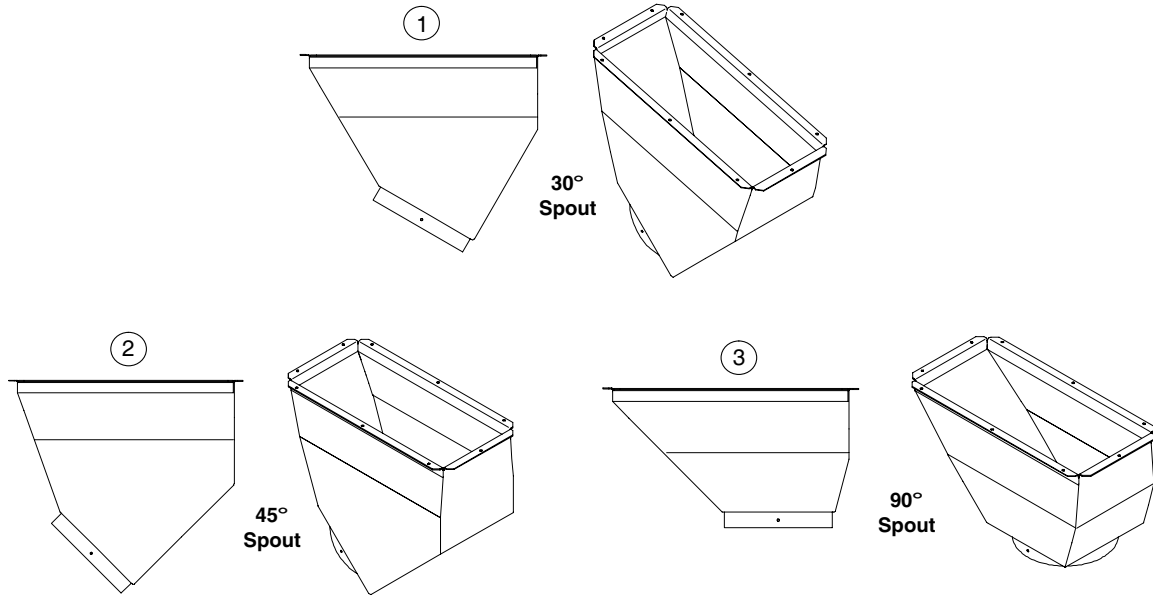

**OPTIONAL SPOUTS**  
**f/ M50 & M85 MODELS**



Ref. No.	Part No.	Description	Ref. No.	Part No.	Description
1	1046290	Spout, 30° w/ 24" Inlet Opening f/ M50 Models	(2)	1044621	Spout, 45° w/ 30" Inlet Opening f/ M85 Models
(1)	1044648	Spout, 30° w/ 30" Inlet Opening f/ M85 Models	3	1046311	Spout, 90° w/ 24" Inlet Opening f/ M50 Models
2	1046289	Spout, 45° w/ 24" Inlet Opening f/ M50 Models	(3)	1044714	Spout, 90° w/ 30" Inlet Opening f/ M85 Models

# PARTS LIST

## TORQUE CHART

<p align="center"><b>General Torque Specification Table</b></p> <p align="center"><b>Use the Following Torques When Special Torques Are Not Given</b></p> <p align="center">Note: These values apply to fasteners as received from supplier, dry, or when lubricated with normal engine oil. They do not apply if special graphited or moly-disulphide greases or other extreme pressure lubricants are used. This applies to both UNF and UNC threads.</p>													
SAE Grade No.		SAE 2				SAE 5				SAE 8*			
Bolt head identification marks as per grade Note: Manufacturing marks will vary													
		Torque		Torque		Torque		Torque		Torque		Torque	
Bolt Size		Foot Pounds		Newton-Meters		Foot Pounds		Newton-Meters		Foot Pounds		Newton-Meters	
Inches	Millimeters	Min.	Max.	Min.	Max.	Min.	Max.	Min.	Max.	Min.	Max.	Min.	Max.
1/4	6.35	5	6	6.8	8.13	9	11	12.2	14.9	12	15	16.3	20.3
5/16	7.94	10	12	13.6	16.3	17	20.5	23.1	27.8	24	29	32.5	39.3
3/8	9.53	20	23	27.1	31.2	35	42	47.5	57.0	45	54	61.0	73.2
7/16	11.11	30	35	40.7	47.4	54	64	73.2	86.8	70	84	94.9	113.9
1/2	12.70	45	52	61.0	70.5	80	96	108.5	130.2	110	132	149.2	179.0
9/16	14.29	65	75	88.1	101.6	110	132	149.2	179.0	160	192	217.0	260.4
5/8	15.88	95	105	128.7	142.3	150	180	203.4	244.1	220	264	298.3	358.0
3/4	19.05	150	185	203.3	250.7	270	324	366.1	439.3	380	456	515.3	618.3
7/8	22.23	160	200	216.8	271.0	400	480	542.4	650.9	600	720	813.6	976.3
1	25.40	250	300	338.8	406.5	580	696	786.5	943.8	900	1080	1220.4	1464.5
1 1/8	25.58	---	---	---	---	800	880	1084.8	1193.3	1280	1440	1735.7	1952.6
1 1/4	31.75	---	---	---	---	1120	1240	1518.7	1681.4	1820	2000	2467.9	2712.0
1 3/8	34.93	---	---	---	---	1460	1680	1979.8	2278.1	2380	2720	3227.3	3688.3
1 1/2	38.10	---	---	---	---	1940	2200	2630.6	2983.2	3160	3560	4285.0	4827.4

\*Thick nuts must be used with Grade 8 bolts





## ***Hutchinson/Mayrath***

*A Division of GLOBAL Industries Inc.*

Hutchinson/Mayrath • P.O. Box 629 • Clay Center, KS. 67432  
Ph. 785-632-2161 • Fx. 785-632-5964 • Toll Free 800-523-6993  
[www.hutchinson-mayrath.com](http://www.hutchinson-mayrath.com)