

# MODEL 85 MASS-TER MOVER

## 81X CHAIN INFO

### CONVEYOR CHAIN AND PADDLE ASSEMBLY

The paddles can be assembled to the conveyor chain before installing the chain into the housing. The chain model number is stamped on the side of the chain links. Be sure that **ALL** of the conveyor chain is the same type. Bolt the paddles to chain using four 5/16" x 1 1/4" bolts, with eight flat washers and four lock nuts per each paddle.

**IMPORTANT: Do not overtighten bolts for attaching paddles to chain. Excessive tightening can deform the paddles. Recommend 15 to 20 ft.-lbs. of torque on paddle bolts.**

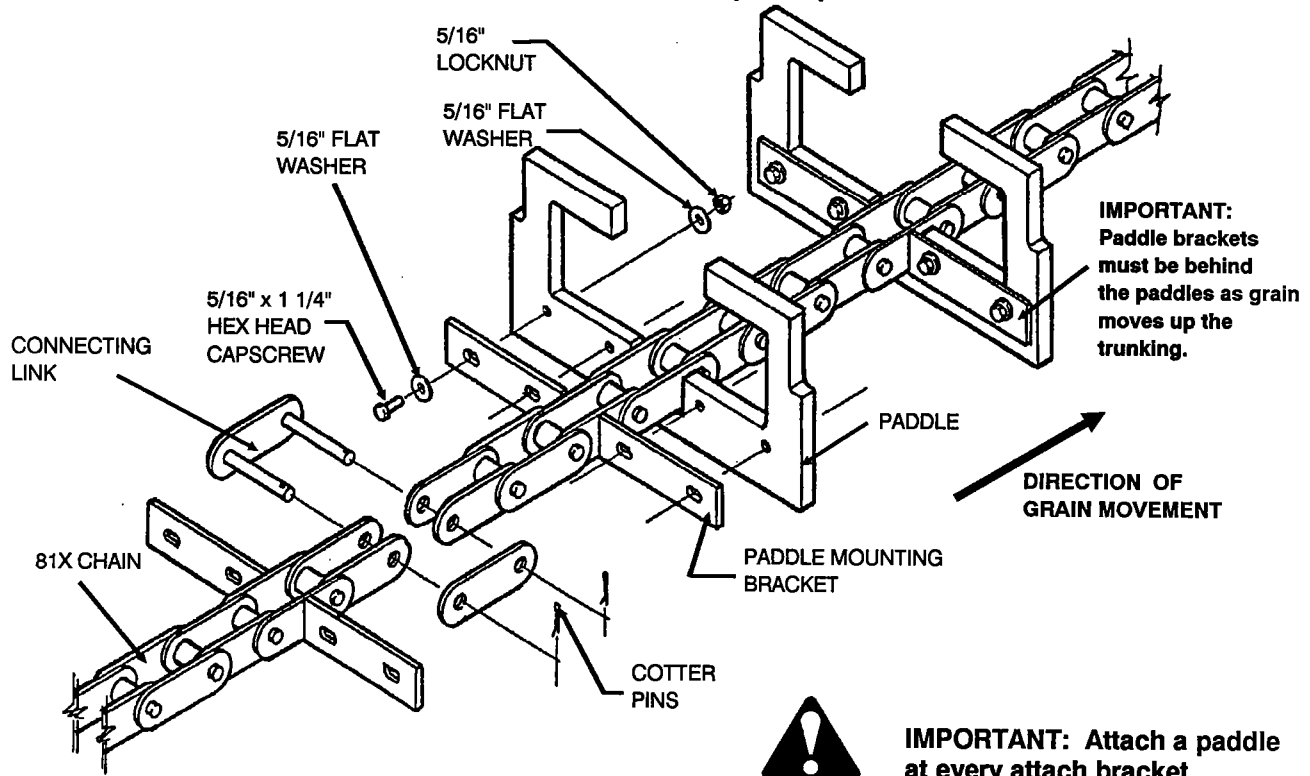

### IMPORTANT SERVICE - MAINTENANCE NOTICE:

The life of the conveyor chain will be shortened when the chain is allowed to sit in water or is operated in acidic conditions, so avoid these situations.

To extend chain life, spray a light coat of oil on the chain after each season's use. Use extreme caution; keep away from moving chain and paddles.

Regular inspections should be established in order to ensure that the conveyor chain is in good operating condition at all times.

1. Inspect the conveyor chain for loose bolts, missing chain parts, missing or damaged chain paddles and the overall chain condition.
2. Check chain tension; see back of sheet for chain adjustment.
3. Check conveyor sprocket to see that it is centered and setscrews are tight.



**Whenever you must service or adjust your equipment, make sure you stop the machine and lock out your power source!**

## CONVEYOR CHAIN TENSION ADJUSTMENT

1. To check conveyor chain tension, grasp one of the paddles at the intake end and attempt to rotate it up toward the chain. See Fig. A. Proper chain tension should allow only minimum rotation of the paddle, perhaps 10 degrees. To adjust, go onto Step 2.
2. Loosen the four carriage bolts on each take-up slide at the discharge end of the unit. Move jam nuts on conveyor chain adjustment bolts in direction desired to either loosen or tighten chain. Jam nuts should be moved equal amounts so that sprocket shaft remains straight. Check it by measuring from the shaft at each bearing to the head end.

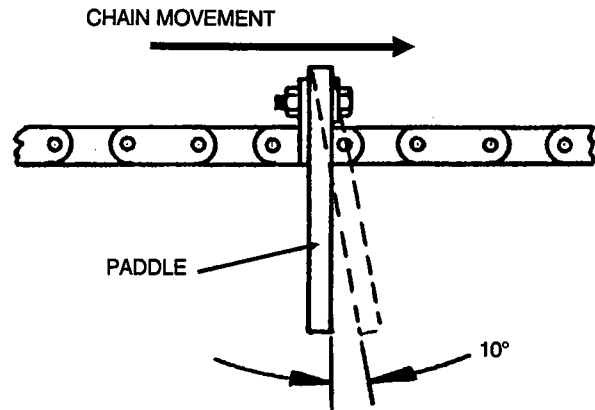

FIG. A

3. If chain is still too loose after these adjustments, it may be necessary to remove one or more links from the chain.
4. Tighten carriage bolts on take-up slides. Make sure main shaft is square with chain and trunking.
5. It is important to operate the conveyor at reduced capacity for the first 1000 bushels until the housing and internal parts become polished. Operate at the recommended speed during this period. Operation at full capacity during this initial period will result in high power requirements. It is important not to overtighten the conveyor chain. However if the chain is not sufficiently tight, it will slip at the lower drive sprocket as capacity is increased. Should this occur, shut off the grain flow to the unit and shut down after the unit has emptied. Tighten the conveyor chain as described above. Limit the tightening process to 1/4" of travel for conveyors 70 ft. and longer and to smaller increments for shorter conveyors. Restart the conveyor and operate normally. The tightening process may be repeated, if necessary. Do not overtighten.

