

16" COMMERCIAL GRAIN PUMP® LOOP CONVEYING SYSTEM

OWNER'S & OPERATOR'S MANUAL

Effective January 15, 2016

Publication No. 1025818

IMPORTANT! The reducer gear box is shipped **Without Oil**.
Oil must be added before conveyor operation.
Refer to the Lubrication Section in this manual.



Hutchinson/Mayrath

A Division of GLOBAL Industries Inc.

Hutchinson/Mayrath • P.O. Box 629 • Clay Center, KS. 67432
Ph. 785-632-2161 • Fx. 785-632-5964 • Toll Free 800-523-6993
www.hutchinson-mayrath.com



Hutchinson/Mayrath

A Division of **GLOBAL** Industries, Inc.

POLICIES AND PROCEDURES

- Prices:** Prices in effect at time of shipment will apply. Prices are subject to change without notice. All prices are F.O.B. Clay Center, Kansas. Orders shipped from locations other than Clay Center, Kansas will be subject to additional charges, such as back freight and/or additional freight.
- Service Charge:** A service charge will be assessed for all past due balances as permitted by state law not to exceed 1-1/2% per month.
- Minimum Order:** Processing and handling costs necessitate a minimum charge of \$15.00 net on all orders.
- Back Orders:** Back orders will be shipped as they become available. Contact Hutchinson/Mayrath Customer Service for alternative shipping options or if cancellation is desired.
- Damaged Goods:** It is the consignee's responsibility to check all shipments thoroughly upon receipt of goods. If any damage is discovered, it must be noted on the freight bill of lading before signing. The consignee must make necessary claims against the respective freight line. All damage claims must be submitted within 30 days of delivery receipt.
- Shortages:** All shortages must be noted at time of delivery. Shortages must be noted on the freight bill of lading before signing. Hutchinson/Mayrath must be advised of all concealed shortages upon discovery. Once notified of concealed shortages Hutchinson/Mayrath will advise corrective action to be taken.
- Return of Goods:** All returns must be approved by Hutchinson/Mayrath prior to shipment. All return requests will be issued a return authorization number. **NO RETURNS WILL BE ACCEPTED WITHOUT A RETURN AUTHORIZATION NUMBER AND PRIOR AUTHORIZATION FROM THE FACTORY.** All returns must be shipped prepaid. A 15% restocking charge will be applied to all returned merchandise. Custom Products may not be returned for credit. Only current products in new and salable condition may be returned. No safety devices may be returned for credit.
- Modifications:** It is the policy of Hutchinson/Mayrath to improve its product whenever possible and practical to do so. We reserve the right to make changes, improvements and modifications at any time without incurring the obligation to make such changes, improvements and modifications on any equipment sold previously.
- Limited Warranty:**
- (a) For a period of (1) year after receipt of goods by the original consumer buyer, Hutchinson/Mayrath will supply free of charge replacement parts for parts that prove defective in workmanship or material. Defective parts must be returned freight prepaid to a specified Hutchinson/Mayrath location. Only Hutchinson/Mayrath original repair parts may be used for warranty repairs.
 - (b) This limited warranty does not extend to parts designed to wear in normal operation and be replaced periodically; or to damage caused by negligence, accident, abuse or improper installation or operation.
 - (c) **GOODS NOT MANUFACTURED BY HUTCHINSON/MAYRATH CARRY ONLY THE MANUFACTURER'S WARRANTY.**
 - (d) **THIS UNDERTAKING IS IN LIEU OF ALL OTHER WARRANTIES, EXPRESSED OR IMPLIED, INCLUDING MERCHANTABILITY AND FITNESS FOR A PARTICULAR PURPOSE.**
- FAILURE TO FOLLOW THE INSTRUCTIONS CONTAINED IN THE OWNER'S & OPERATOR'S MANUALS AND THE ITEMS LISTED BELOW WILL RESULT IN THE VOIDING OF THIS LIMITED WARRANTY.**
- (1) Improper assembly, including failure to properly install all safety equipment.
 - (2) Improper installation.
 - (3) Unauthorized alternations of goods.
 - (4) Goods operated when obviously in need of repair.
 - (5) Use of unauthorized repair parts.
 - (6) Irresponsible operation.
 - (7) Used to handle materials other than free flowing, nonabrasive and dry materials, as intended.
 - (8) Damaged through abusive use or accident.
- Limitation of Liability:** BUYER AGREES THAT IN NO EVENT SHALL HUTCHINSON/MAYRATH HAVE LIABILITY FOR DIRECT DAMAGES THE EXCESS OF THE CONTRACT PRICE OF THE GOODS IN RESPECT OF WHICH CLAIM IS MADE. BUYER FURTHER AGREES THAT IN NO EVENT SHALL HUTCHINSON/MAYRATH ON ANY CLAIM OF ANY KIND HAVE LIABILITY FOR LOSS OF USE, LOSS OF PROFITS, OR FOR ANY INDIRECT, INCIDENTAL OR CONSEQUENTIAL DAMAGES.

TABLE OF CONTENTS

POLICIES AND PROCEDURES	(Inside Front Cover)
TABLE OF CONTENTS	1
SAFETY	2 - 4
General Safety Statement	2
Safety Alert Symbol and Safety Information	2-3
Safety Decals	4
Grain Bin Safety	4
GENERAL INFORMATION	5 - 8
Operator Qualifications	5
Sign-Off Sheet	5
Machine Inspection	6
Conveyor Horsepower Information	6
Electric Motor Drive Information	6
How to Calculate Total Horsepower	7
Start-Up & Break-In Information	8
Designated Work Area	8
Full Load Operation Information	9
OPERATING PROCEDURES	10
Conveyor Operating Procedures	10
Shutdown/Lockout	10
LUBRICATION & MAINTENANCE	11 - 14
General Maintenance Information	11
Conveyor Chain	11
Bearings: Inspection Corner, Drive & Standard Corners, R&P Dump Hopper	12
Flat Storage Well	13
Loop System & Drop Assemblies	13
Drive and Corner Sprockets	13
Drive Belts	13
Gear Reducer	14
Trouble Shooting	15
ASSEMBLY INSTRUCTIONS	16 - 32
Installation and Layout	16
Installation Information	16
Layout Considerations and Layout Information	16-17
System Support Information and Grain Flow & Drive Corner Location	18
Tube, Corner and Discharge w/ Gate Assembly	19
Reversing Discharge Tube	20
Inlet Dump Hopper	21
Auto Take-Up Inspection Corner	22
Drive Corner	23
Conveyor Chain and Paddle	24
Discharge w/ Cable Ground Control Gates	25-26
Discharge w/ Chain Ground Control Gates	27-30
Inspection Ports (Band-On)	31
Chain Maintenance Access Assembly	32
PARTS LIST TABLE OF CONTENT	P-1
PARTS LIST	P-2 - P-15

SAFETY

GENERAL SAFETY STATEMENT

This manual was written with the safety of the operator and others who work with the equipment as our prime concern. The instructions presented will help the reader learn **SAFE** day to day work practices. We want you as our partner in safety.

It is your responsibility as an owner, operator or supervisor to know what specific safety requirements and precautions exist and to make these known to all other personnel working with the equipment or in the area, so that they too may safely perform their duties and avoid any potentially hazardous situations.

We suggest the implementation of a Safety Program for all personnel that includes, but is not limited to, the proper use of PPE (personal protective equipment), Fall Protection Systems and Lock Out-Tag Out procedures.

Please remember safety equipment provides important protection for persons around a grain handling system that is in operation. Be sure **ALL** safety shields and protection devices are installed and properly maintained. If any shields or guards are damaged or missing, contact your dealer to obtain the correct items.

Avoid any alterations of the equipment. Such alterations may create a dangerous situation where serious injury or death may occur.

SAFETY ALERT SYMBOL

The safety symbol shown is used throughout this manual to alert you to information about unsafe actions or situations, and will be followed by the word DANGER, WARNING, or CAUTION.

DANGER - Indicates immediate hazards that may result in severe injury or death. **WARNING** - Indicates unsafe actions or situations that may cause severe injury, death and/or major equipment or property damage. **CAUTION** - Indicates unsafe actions or situations that may cause injury, and/or minor property damage.

Watch this symbol - it points out important safety precautions. It means - **ATTENTION! Become alert! Your safety and the safety of others is involved!** Read the message that follows the symbol when a warning is given, be alert to the possibility of personal injury or death.



Follow Safety Instructions

Carefully read all safety messages in this manual and safety signs on your machine. Check to ensure all Safety Decals are present and in good condition.

If a decal cannot easily be read for any reason, or has been painted over, replace the decal immediately. Safety decals are offered free of charge, and can be ordered through your Hutchinson/Mayrath dealer or directly from the factory.

Learn how to operate the machine and how to use controls properly.

Keep your machinery in proper working condition. Understand service procedures before doing work. Never lubricate, service or adjust machine while it is in operation.

Keep work area clean, dry and free from of all debris and tools which may cause accidental tripping or falling.



Read and Understand Manual

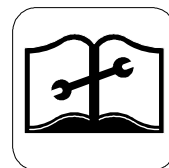

Understand Service Procedures



Keep Work Area Clean

Prepare for Emergencies

Keep emergency numbers for doctors, ambulance service, hospital and fire department near your telephone.

Keep a first-aid kit and fire extinguisher handy.

Be prepared if a fire starts

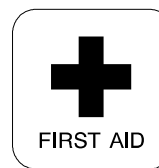

First Aid Equipment



Fire Extinguisher

Wear Proper PPE (Personal Protective Equipment)

Some materials can create flying debris when they are filed, cut or drilled. Safety glasses should be worn at all times to protect your eyes from such debris.

Hearing protection should be worn when operating power tools or other power equipment that could be harmful to your hearing.

Gloves should be worn to protect your hands from sharp metal and plastic edges, as well as providing protection from the handling of heavy objects.

Wear steel toe boots to protect your feet from falling debris.

Wear a hard hat to help protect your head from falling objects as well as from accidental bumping.

Use caution when working at elevations greater than four (4) feet (1.22 m) above the ground.

Use the appropriate fall protection equipment as set forth by OSHA guidelines and regulations.

A respirator may be needed to prevent breathing potentially toxic fumes and dust, especially when working within a grain bin or storage structure.

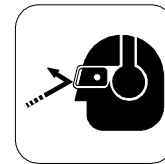

Eye & Hearing Protection

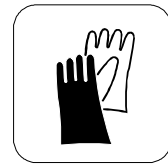

Gloves



Steel Toe Boots



Hard Hat



Fall Protection

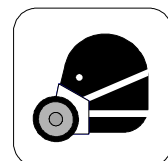

Respirator

Operate Electric Motor(s) Properly

Do not operate electric motor equipped units until motor(s) are properly grounded.

Know how to "Shutdown and Lockout" the power source. Shutdown and lockout power source before performing any service, maintenance or adjustments to the unit.

Disconnect power on electrical driven units before resetting motor overloads.



Lockout / Tagout



Electric Shock Hazard

Stay Clear of Moving Parts

Keep all shields, covers and safety devices in place at all times.

Entanglement in moving chains, rotating impeller arms and sprockets will cause serious injury or death.

Wear close fitted clothing. Keep hands, feet and clothing away from moving parts.

Shutdown and lockout power source before making adjustments, cleaning or maintaining the equipment.

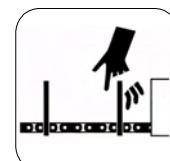

Entanglement Hazards

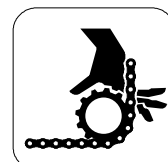

SAFETY

GRAIN BIN SAFETY

The Commercial Loop System is generally designed to move grain into or from grain bins or other storage structures. **Be aware of the dangers inherent in grain bins.**

Consult the grain bin manufacturer's manual for information on the proper loading and unloading of the bins, structural stress analysis, adequate venting and important safety information.



WARNING! Do Not enter the bin if the grain has “Bridged” or has not flowed normally out of the bin, See Example’s 1 & 2. The grain may suddenly break loose and bury resulting in suffocation.



Do Not enter the bin unless all power driven equipment has been shut down and locked out. Never enter the bin unless monitored by another person.

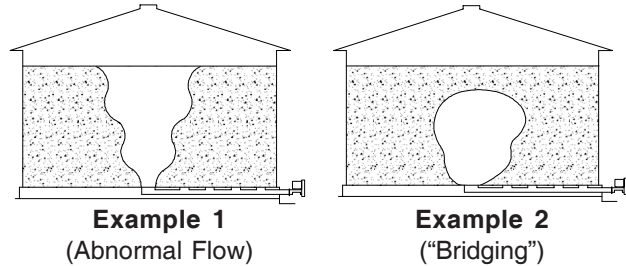

SAFETY DECALS

Check to ensure all Safety Decals are present and in good condition. If a decal cannot easily be read for any reason, or has been painted over, replace the decal immediately. Safety decals are offered free of charge, and can be ordered through your Hutchinson/Mayrath dealer or directly from the factory.

Refer to the Parts List Section for decal Part No's. and location of decals on components.

NOTE: Not all decals will be shown on all components.

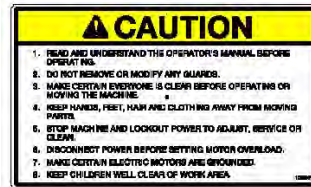

OPERATOR QUALIFICATIONS



WARNING

Anyone who will operate or work around this machine shall first read this manual! This manual must be delivered with the equipment to its owner. Failure to read this manual and its safety instructions is considered misuse of the equipment.

Operation of this conveyor system shall be limited to competent and experienced persons. In addition, anyone who will operate or work around a conveyor must use good common sense. In order to be qualified, he must also know and meet all other requirements, such as:

1. Some regulations specify that no one under the age of 16 may operate power machinery. This includes this conveyor. It is your responsibility to know what these regulations are in your area or situation.
2. Current OSHA regulations state in part: "At the time of initial assignment and at least annually thereafter, the employer shall instruct every employee in safe operation and servicing of all equipment with which the employee is, or will be involved." *
3. Unqualified persons are to stay out of the work area. See Page 6.
4. A person who has not read and understood all operating and safety instructions is not qualified to operate the machine.
5. Persons operating, servicing or repairing equipment that requires above ground work shall be properly secured with the use of "fall protection" equipment as set forth by OSHA guidelines and regulations.

*Federal Occupational Safety & Health Standards for Agriculture Subpart D, Section 1928.57 (a) (6).

SIGN OFF SHEET

As a requirement of OSHA, it is necessary for the employer to train the employee in the safe operation and safety procedures with this conveyor. We include this sign off sheet for your convenience and personal record keeping.

<i>Training Sign-Off Sheet</i>		
Date	Employer Signature	Employee Signature

SERIAL NUMBER

To ensure efficient and prompt service, please furnish us with the model and serial number of your conveyor in all correspondence or other contact. The serial plate is located on each of the drive corners.

GENERAL INFORMATION

MACHINE INSPECTION

After completion of assembly and before each use, inspection of the machine is mandatory. This inspection should include, but not be limited to:

1. Inspect the conveyor for loose bolts, missing chain parts, missing or damaged paddles and the overall chain condition.
2. Check chain tension.
3. Check the condition and tension of drive belts and adjust as necessary.
4. Inspect sheaves for alignment and see that they are securely fastened.
5. Check oil level in drive reducer.
6. Check all safety signs and replace any that are worn, missing or illegible. The safety signs are listed in the front of this manual. Safety signs may be obtained free of charge from your dealer or ordered from the factory.
7. Check that all safety devices, guards and shields are installed and that all inspection doors are latched closed.
8. Check auto take-up corner, if so equipped. See that the sprocket carriage is free to move up and down. Lubricate, as necessary.

Obtain any needed replacement parts from your dealer and install before using the machine.

CONVEYOR HORSEPOWER (KW) INFORMATION

The height and length of a loop system are limited by the combined power required to move grain those distances. The vertical component requires greater power per foot (*meter*), so taller units will be more limited in horizontal length. System lengths of several hundred feet are common. However, relatively small systems to accomplish more specific tasks are often built.

Loop units are provided with Dodge gear reducer drives to be driven by one or two electric motors. There are maximum power limits for each drive, but when greater power than can be provided by one drive is needed, a second drive of equal power can often be added. Drives are always located at upper corners. A single drive must always be located at the top corner after the last discharge.

Overfeeding a grain pump loop may cause plugging. We recommend the loading rate be monitored by an amp meter on the electric motor drive(s).

CONVEYOR HORSEPOWER (con't.)

The Grain Pump® will operate more smoothly, move more grain and last longer if loaded 80% of fill, instead of an uncontrolled approach to 100% of fill. "Soft Start" motors are always recommended to protect a conveyor from high torque shocks against a unit that may have inadvertently been stopped under load or plugged.

ELECTRIC MOTOR DRIVE INFORMATION



WARNING! A main power disconnect switch that can be locked in only the "OFF" position shall be provided. This shall be locked whenever work is being done on the conveyor.



The reset and starting controls must be located so that the operator has full view of the entire operation.

Do Not enter the grain bin unless all power driven equipment has been shut down and locked out.

Make certain electric motor is grounded.



Disconnect power before resetting motor overloads.

Shut off power and lockout whenever cleaning or servicing the conveyor.

Always use a motor with required HP (*kw*) as calculated on previous page (Page 7). Use a 60 hz motor that operates at 1750 rpm (*50 hz @ 1460 rpm*). **Units using 50 hz motors require different drive pulleys, consult factory for specifications.**

Electrical motor and controls shall be installed by a qualified electrician and must meet the standards set by the National Electrical Code and all local and state codes.

A magnetic starter should be used to protect your motor when starting and stopping. It should stop the motor in case of power interruption, conductor fault, low voltage, circuit interruption or motor overload. Then the motor must be restarted manual.

Some motors have built-in thermal overload protection. If this type motor is used, use only those with a manual reset.

Install with an ampmeter on motor or motors, so that the load can always be monitored to prevent overloading.

A main power disconnect switch that can be locked only in the "Off" position shall be installed. This shall be locked whenever work is being done to the conveyor.

HOW TO CALCULATE TOTAL HORSEPOWER (KW)

NOTE: The power recommendations are for conveying reasonably dry grain at approximately 56 lbs. per bushel (720 kg per cu. meter). Adjust the power requirements up or down for material of a different density.

1. Determine the vertical height of the system, usually the peak height of the tallest bin plus 4' (1.22 m). **Multiply the vertical height by the vertical HP factor of 1.35 (3.3 kw) to determine the vertical power requirement.**
2. Add the total upper and lower horizontal length of conveyor that will contain material during operation. If you plan to recirculate the grain at full capacity from one storage structure to another, it may add length to the power calculation. **Multiply the total horizontal length by the horizontal HP factor .30 (.73 kw) to determine the horizontal power requirement.**
3. Add the vertical and horizontal power together to find the total system power required.

NOTE: As stated in the Conveyor Horsepower Information section, there are maximum power limits for the drive motors. For excessively long runs (horizontal) with short heights (vertical), the far drive corner can only pull grain for its rated HP/HP per ft.

To determine the maximum horizontal length a motor can handle: **divide the motors rated HP by the horizontal HP factor .30 (.73 kw).**

For example, to determine how long of a horizontal run you can have using a 100 HP motor.

Pump Dia.	100 HP (74.6 kw)
16"	HP (kw) factor = .30 (.73)

**100 divided by .30 = 333 ft.
that is the maximum distance grain
can be moved in the top tube.**

When determining the length of your system, take into consideration, not only the horizontal and vertical HP required as determined below, but the limits of the rated HP/HP per ft. of the motor.

Pump Dia.	Vertical per ft. (m)	Horizontal per ft. (m)
16"	HP (kw) factor = 1.35 (3.3)	HP (kw) factor = .30 (.73)

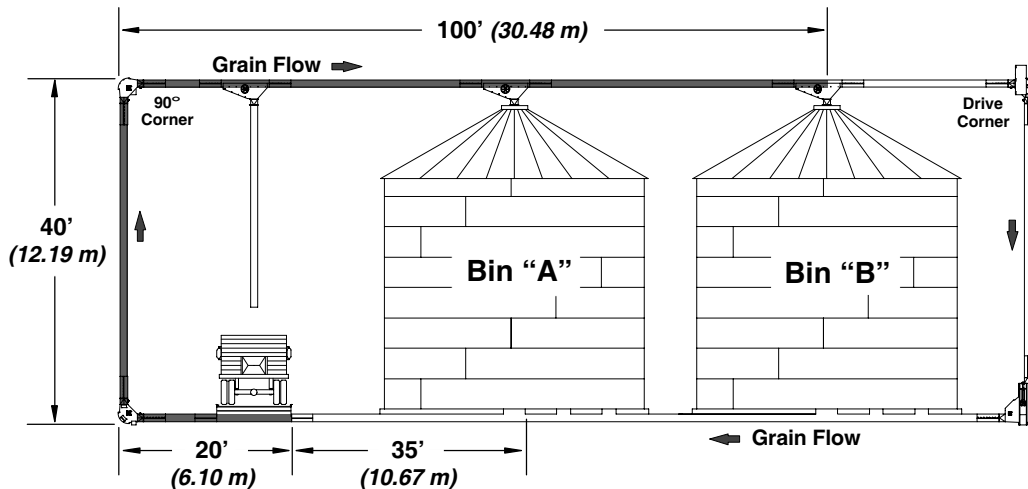

In this example, there is 40 ft. (12.19 m) of vertical conveyor and 120 ft. (36.58 m) of horizontal conveyor that will contain grain.

Vertical HP Requirement 40' (12.19 m) x 1.35 (3.3) HP (kw) factor = 54 (40.3 kw)

Horizontal HP Requirement 120' (36.58 m) x .30 (.73) HP (kw) factor = 36 (28.8 kw)

Total HP (kw) - Vertical + Horizontal = 90 (37.1 kw)

Electric Motor size required = 100 HP (74.6 kw), 75 kw for 50HZ motor

If there are plans to transfer grain from Bin A to Bin B, an additional 35 ft. of horizontal length must be added to the calculation.

Horizontal HP (kw) requirement, 35' (10.67 m) x .30 (.73) HP (kw) factor = 10.5 (7.8 kw) added to previous 90 (37.1 kw)

Total HP (kw) - Vertical + Horizontal = 100.5 (74.9 kw)

Electric Motor Size Required = 100 HP (4.6 kw), 75 kw for 50HZ motor

**START-UP and
BREAK-IN INFORMATION**

WARNING! During initial start-up and break-in period, the operator shall be aware of any unusual vibrations or noises that would indicate a need for service or repair.



Keep all safety shields and devices in place. Keep hands, feet, and clothing away from moving parts.



The operator should have a full view of the conveyor work area and check that all personnel are free from designated work areas before adding power.

It is essential to inspect your conveyor and drive components before adding power and to know how to shut down in an emergency. During the operation of your conveyor, one person shall be in a position to monitor the operation.

During the initial start-up and break-in period, the operator should watch for any unusual vibrations or noises.

Any conveyor, when it is new or after it sits idle for a season, should go through a “break-in” period. It should be run at partial capacity at full speed until the inside of the housing becomes polished, before attempting full capacity. A failure will most likely occur when it is run at full capacity before it has a chance to “shine up”.

If at all possible, do not start or stop the Grain Pump® Conveyor under load, especially before the housing becomes well polished, as this may cause the unit to stall. If so equipped, inspect and lubricate the automatic take-up corner. Be sure that the sprocket carriage is free to move up and down.

DESIGNATED WORK AREA

The area around the conveyor and inside the grain storage units is considered the work area. Use the following to ensure a safe working environment.



WARNING! Under no circumstances should persons not involved in the operation be allowed to trespass into the work area.

It shall be the duty of all operators to see that children and/or other persons stay out of the work area! Trespass into the work area by anyone not involved in the actual operation, or trespass into a hazard area by anyone shall result in an immediate shutdown by the operator.



It shall be the responsibility of all operators to see that the work area has secure footing, is clean and free of all debris and tools which might cause accidental tripping and/or falling. It shall also be their responsibility to keep the work area clean and orderly during the operation.



Use caution when working in areas above the ground. Persons operating, servicing or repairing equipment that requires above ground work shall be properly secured with the use of “fall protection” equipment as set forth by OSHA guidelines and regulations.



Metal buildings, scaffolding and other types of work surfaces can become slippery, especially when surfaces are wet and/or oily. This can create hazardous working conditions. Use caution when working, climbing or walking on these surfaces.

FULL LOAD OPERATION INFORMATION

Operation of the Grain Pump® Conveyor will generally include moving grain into or out of grain storage structures.

Grain will enter the conveyor through a dump hopper or through bin wells in grain bins. There are flow control devices included with these components that should be used to control grain flow rates into the conveyor.

It is possible to use more than one inlet component at the same time, such as when blending is desired or simply to increase the flow rate into the conveyor.

Grain is discharged from the conveyor through outlets with movable gates for opening and closing the outlets. Optional ground controls are available for operating the gates. All gates should be closed except the one at the selected discharge point.

Typically with a system of this size, a sweep auger is installed and kept inside the bin. Refer to the operator's manual that is supplied with the sweep auger for installation instructions and safety practices.



WARNING! Do Not enter the bin if the grain has "Bridged" or has not flowed normally out of the bin, See Fig's. 1 & 2. The grain may suddenly break loose and bury resulting in suffocation.



Do Not enter the bin unless all power driven equipment has been shut down and locked out. Never enter the bin unless monitored by another person.

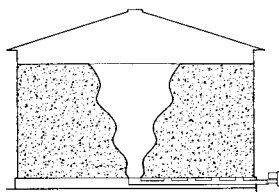

Fig. 1
(Abnormal Flow)

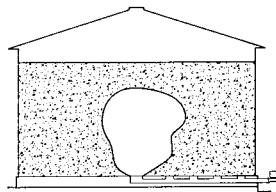

Fig. 2
("Bridging")

FULL LOAD OPERATION INFORMATION (con't.)

For unloading bins into a truck, the operator may want to leave the discharge gate over the bin being unloaded open, in addition to the discharge gate over the truck load-out. This will allow the operator to close the gate to the truck when it is full and let the loop clean-out as the inlet (bin well) is closed (See Fig's. 3 & 4).

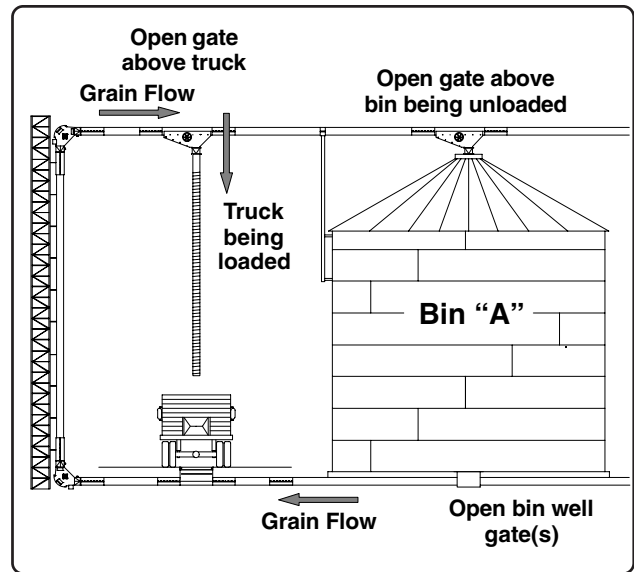

Fig. 3

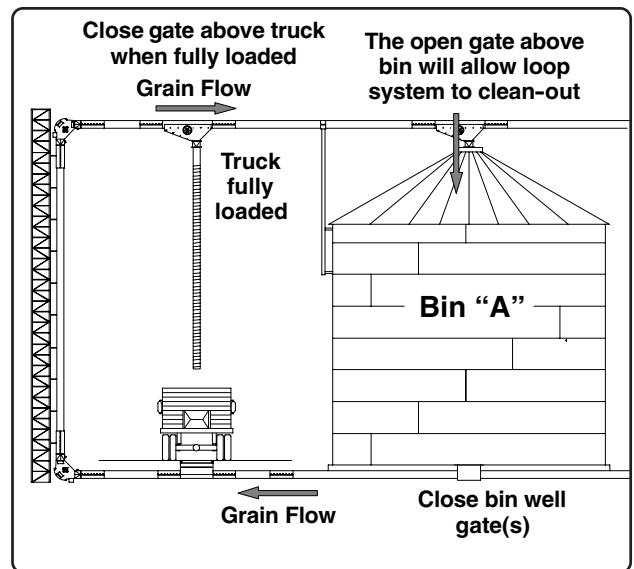

Fig. 4

OPERATING PROCEDURES

WARNING! Make certain everyone is clear before operating the equipment.

The operator shall be aware of any unusual vibrations or noises that would indicate the need for service or repair.

Keep all safety shields in place.

Keep hands, feet and clothing away from moving parts.



The operator shall have a full view of the entire work area and check that all personnel are clear of the designated work area before adding power.

If the operator must leave the work area, or whenever servicing or adjusting, the conveyor must be stopped and the power source turned off and locked out.



Precaution should be made to prevent anyone from operating the conveyor when the operator is absent from the work area.

The reset and starting controls must be located so that the operator has full view of the entire operation.

Do Not enter the grain bin unless all power driven equipment has been shut down and locked out.

Make certain electric motor is grounded.



Disconnect power before resetting motor overloads.

Shut off power and lockout whenever cleaning or servicing the conveyor.

Never enter the bin when the sweep auger is in operation. Never attempt to control the operation of the sweep auger by pushing on an operating sweep auger with shovels, brooms or other devices.



Do Not attempt to restrain the movement of the sweep auger by attaching ropes, bars or other devices to be held by an operator.

1. Start the conveyor for operation. Open the conveyor outlet gate for the desired discharge point (all gates should be closed except the one at the selected discharge point). See Fig's. 3 & 4 on previous page for more load-out gate information.

2. If moving grain from bins or storage structures, gradually open the gate in the center well until desired flow is established. **Do Not** overload the conveyor. **Inspection ports should be used to help monitor grain level.**

If intermediate wells are used, they should be opened **after** grain has stopped flowing into the center well.

When the desired amount of grain has been moved or unloaded, close all bin wells and allow the conveyor to clean itself out. **Shut down and lock out power source.**

3. If moving grain through a dump hopper, begin unloading grain from dump vehicle in small increments and gradually build up to desired flow. **Do Not** overload conveyor.

After grain flow from dump vehicle has stopped, allow the conveyor to clean itself out and close outlet gate.

Shut down and lock out power source.

EMERGENCY SHUTDOWN

Should the machine need to be immediately shut down under full load, **disconnect** and **lockout** the power source. Clear as much grain from the hopper and conveyor as possible. Use the release door provided in the standard corner to drain the vertical tube after the dump hopper.

Never attempt to restart when full. Starting the unit under full load may result in damage. Such damage is considered abuse of the equipment and will not be warranted.

NORMAL SHUTDOWN

Close flow controls in bin wells and allow the conveyor to empty before stopping the unit.

Before the operator leaves the work area, the power source shall be locked out.

INTERMITTENT SHUTDOWN

When a conveyor is stopped and started under full load, it may result in damage to the conveyor. Therefore, if intermittent operation is to be carried out, it is advisable to reduce the load level.

If a conveyor is kept from absolute filling, it will make start-up easier and will convey grain more efficiently.

LOCKOUT

The power source shall have a main disconnect box that can be locked only in the "**Off**" position. This is what "shutdown and lockout" refers to, shut off the main power source and lock handle or breaker switch in the "**Off**" position.

GENERAL MAINTENANCE INFORMATION

 **WARNING!** A main power disconnect switch that can be locked in only the “OFF” position shall be provided. This shall be locked whenever work is being done on the conveyor.

 **Keep all safety shields and devices in place.**

 **Never clean, adjust or lubricate a machine that is in operation.**

Disconnect power before resetting motor overloads.

 **Shut off power and lockout whenever cleaning or servicing the conveyor.**

 **Keep hands, feet and clothing away from moving parts.**

For economical and efficient operation of your Grain Pump® maintain regular and correct lubrication. Neglect leads to reduced efficiency, excessive wear, and needless down time. Regular inspections should be established in order to ensure that the equipment is in good operating condition at all times. Use the “Machine Inspection” list on Page 6 for guidelines.

The following information will detail the parts that require lubrication and the various conditions that determine the frequency span.

CONVEYOR CHAIN

It is important not to overtighten the conveyor chain. However, if the chain is not sufficiently tight, it will slip at the drive sprocket as capacity is increased. Should this occur, shut off grain flow to the unit and allow conveyor to clean itself out. **Shutdown and lockout the power source (See Page 10).**

To check conveyor chain tension, open the inspection door, grasp one of the paddles and attempt to rotate it up toward the chain. Proper chain tension should allow only minimum rotation of the paddle (See Fig. 5).

Inspect the conveyor chain for loose bolts, missing chain parts, missing or damaged chain paddles and the overall chain condition.

IMPORTANT SERVICE - MAINTENANCE NOTICE:

The life of the conveyor chain will be shortened when the chain is allowed to sit in water or is operated in acidic conditions, so avoid these situations as much as possible.

To extend chain life, spray a light coat of vegetable oil on the chain after each season’s use.

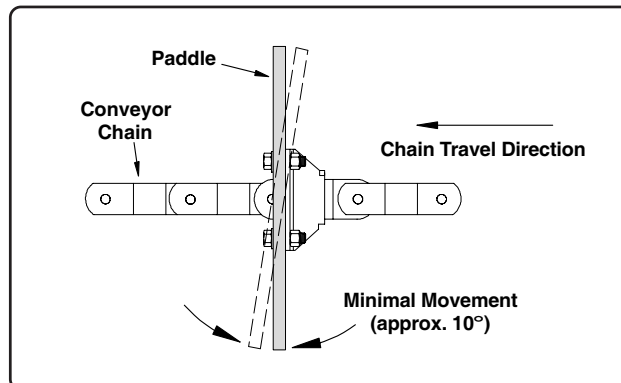

Fig. 5

Another indicator of proper chain tension is whether the traction wheel is turning while the loop system is running. When the chain gets slack in it, it loses contact with the smooth surface of the traction wheel so the wheel and shaft do not turn.

Also, the wheel and shaft may turn when the loop is being run with no-load, but when loaded, slack is created and the shaft and wheel will not turn.

To check chain tension in this manner, stop loop system operation, shut off power and lockout power source.

Remove one of the bearing safety caps from the traction wheel bearing shaft. Start loop system operation and note if shaft is turning (See Fig. 5A). Run both no-load and loaded to help determine proper tension. Adjust chain tension accordingly. Replace bearing cap prior to continuous operation.

Additional weights may need to be added to auto take-up for correct chain tension.

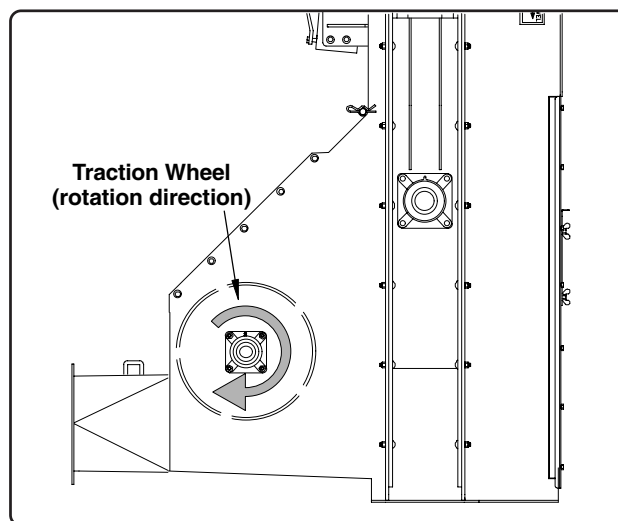

Fig. 5A

BEARING LUBRICATION

The bearings used in the various components of the loop system are equipped with lubrication fittings (grease zerks).

These bearings are self-aligning, sealed ball bearings which have been packed at the factory. They should be lubricated at approximately **fifty (50) hour intervals** with an SAE multipurpose type grease (See Fig. 6, Fig. 7, Fig. 8 & Fig. 9).

Typically only 1 pump is sufficient, Do Not over grease as this may damage the seals on the bearings.

Inspect bearings closely for wear and/or seal damage. Check that the bearings and lock collars are firmly fastened.

These bearings use an eccentric type lock collar. To tighten this type of lock collar, first slide it against the cam end of the inner ring of the bearing. Rotate collar in the direction of shaft rotation until the cams engage. Tap the collar further into this rotation to lock it, then tighten the setscrew.

Check all setscrews and hardware for tightness.

Inspection Corner Lubrication

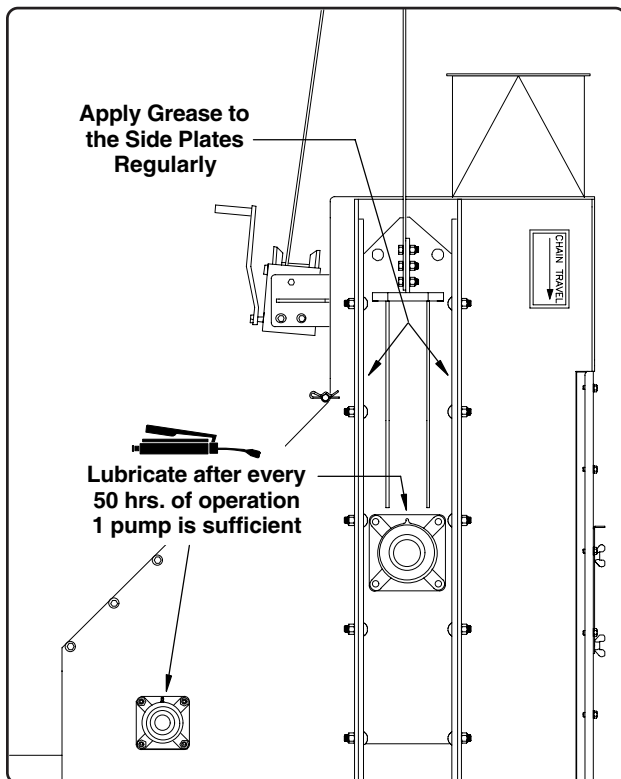

Fig. 6

Dump Hopper w/ Rack & Pinion Lubrication (typical for all dump hoppers w/ rack & pinion)

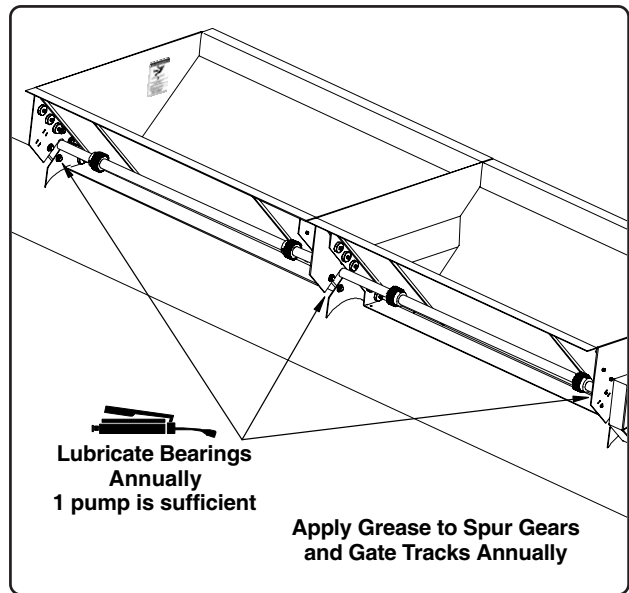

Fig. 7

Standard Corner & Drive Corner Lubrication

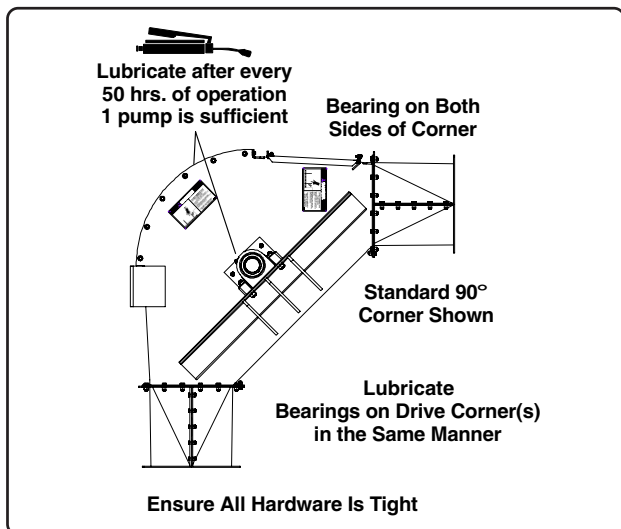

Fig. 8

BEARING LUBRICATION (con't.)

Flat Well Lubrication

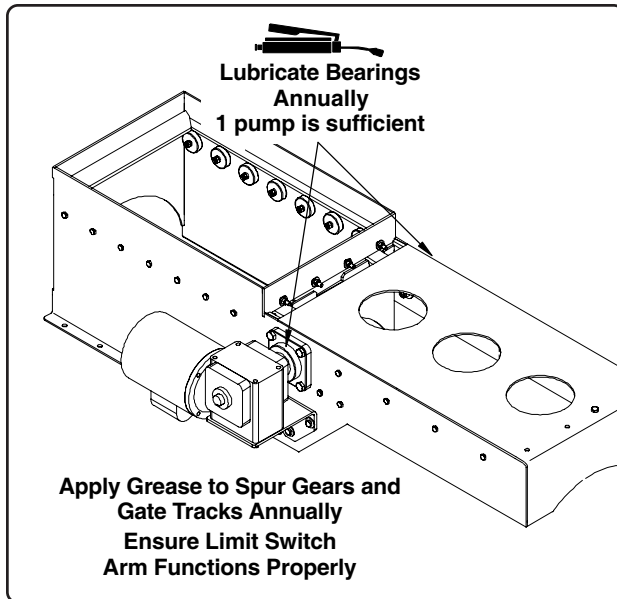

Fig. 9

LOOP SYSTEM & DROP ASSEMBLIES

Check hardware and fasteners to make sure they are all in place and secure.

For ground control discharge drops, ensure cables or chains are properly routed around the sprocket and pulleys (rollers) and operate freely.

Check connecting bands to ensure they are secure.

Ensure all hardware securing the towers and other support systems are tight and properly installed.

DRIVE AND CORNER SPROCKETS

The conveyor chain sprockets should be occasionally checked against sliding on the shaft. The sprockets must be centered in the middle of the housing.

Ensure the sprockets are centered in the housing and the setscrews are tight securing the sprocket into place.

DRIVE CORNER BELTS



WARNING! A main power disconnect switch that can be locked in only the "OFF" position shall be provided. This shall be locked whenever work is being done on the conveyor.

The drive belt tension should be checked regularly. Check belts for tightness, cracking, fraying or other damage. Replace as necessary.

DRIVE CORNER BELTS (con't.)

To tighten belts, turn the 3/4" nuts on the motor mount rods to raise the motor mount assembly (See Fig. 10). Raise all the rods the same distance so the motor mount assembly is parallel with top of conveyor trunking.

Proper tension is 1/2" (13 mm) of deflection per belt when belts are firmly pressed at the center of the span between the two sheaves.

Sheaves must be aligned with each other. Check alignment by placing straight edge across the outer face of both sheaves.

Check that drive keys are properly installed and mounting bolts in sheave taper lock bushings are tight.

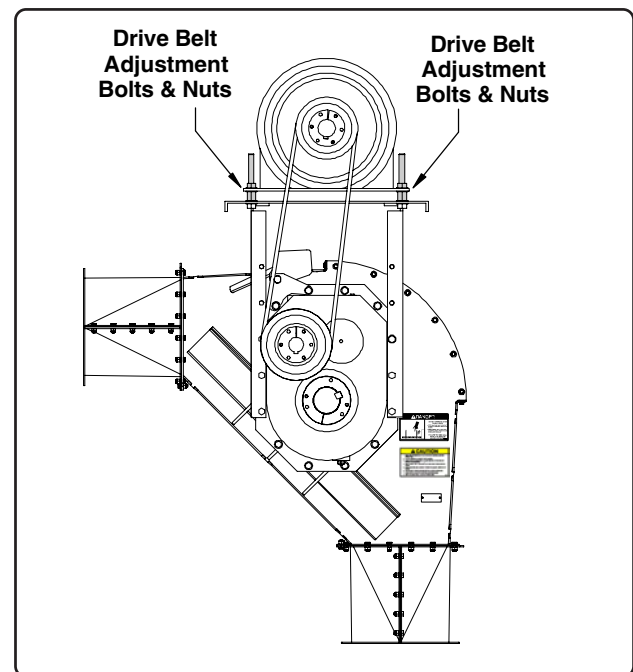

Fig. 10

GEAR REDUCER

IMPORTANT! Because the gear reducer is shipped **without oil**, it is necessary to add the proper amount of oil before conveyor operation. Use a high grade petroleum base, rust and oxidation inhibiting (R & O) gear oil. **Follow the instructions on the reducer name plate, warning tags, and in the instruction manual provided with the reducer.**

Under normal industrial operating conditions, the lubricant should be changed every **2500 hours of operation or every six (6) months**, whichever occurs first. Drain the reducer and flush it with kerosene, clean the magnetic drain plug and refill reducer to its proper level with new lubricant.

CAUTION: Too much oil will cause overheating and too little oil will result in gear failure. Check oil level regularly

Under extreme operating conditions, such as rapid rise and fall of temperature, dust, dirt, chemical particles, chemical fumes, or oil pump temperatures above 200°F (93.3°C), the oil should be changed every **1 to 3 months** depending on severity of conditions.

For reducers operating in ambient temperatures that range between -22°F (-30°C) and 20°F (-6.6°C), the use of a synthetic hydrocarbon lubricant, 100 grade or AGMA 3 grade (for example, Mobil SHC627) is recommended.

Capacities:

Reducer TA8407H25 f/ 100 HP (75 kw) system approx. 25.1 qts. (23.8 L)

Reducer TA8407H15 f/ 125 HP (90 kw) system approx. 25.1 qts. (23.8 L)

All gearboxes are the “double reduction” series. The 100 HP and 125 HP reducers are oriented in Position “D” as shown in the manual provided with the gearbox.

Note: These oil fill levels apply to loop systems which are installed vertically. For angled loop systems consult the manual provided with the gearbox for proper oil level.

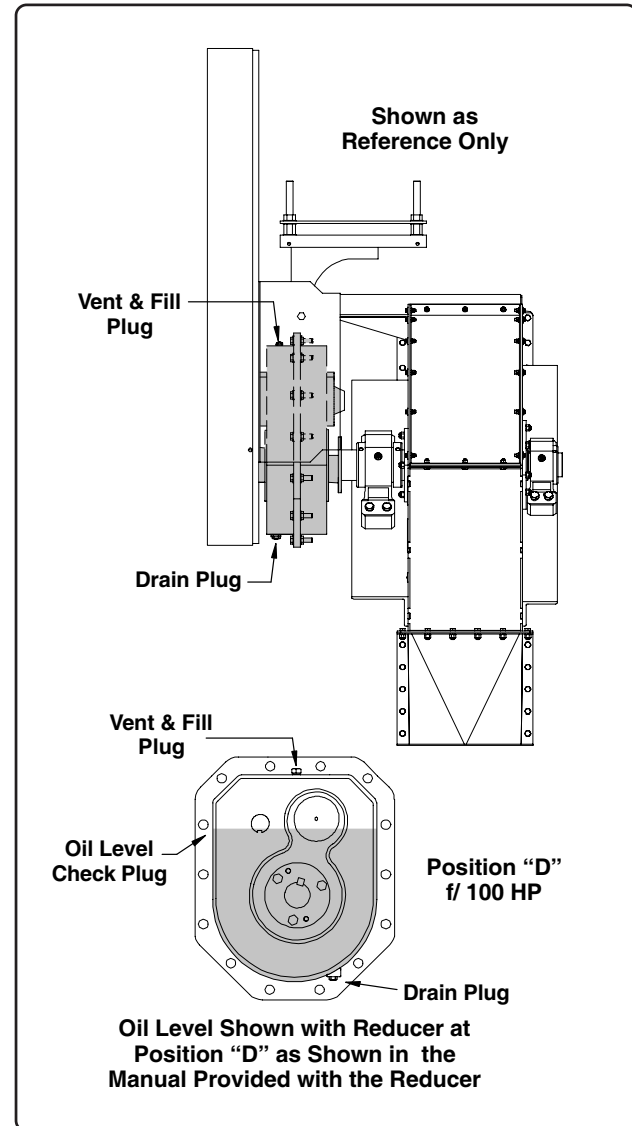

Fig. 11

TROUBLE SHOOTING



CAUTION! A Grain Pump Loop must have an operator who is responsible for the operation of the conveyor. It is this person's responsibility to see the Grain Pump is operated properly.

1. Extreme noise from housing.

- A. Conveyor chain is too loose. Chain is slipping at drive sprocket. Check chain tension and adjust, as necessary.
- B. Improper assembly or misalignment of housing. Locate tube connection(s) that is the source of noise and disassemble. Check for end smoothness and grind, if necessary.
- C. A conveyor sprocket is not centered in a corner unit causing paddles to rub hard on conveyor sides. Sprocket must be moved on shaft to center position and locked.

2. Belt slippage on electric drive.

- A. Incorrect belt tension. Turn the adjustment bolts on the motor mount until proper tension is reached.
- B. Unit is plugged. Clear the grain and any obstructions from the machine as is possible.

3. Grain returning to the intake.

- A. All discharge spout gates may be closed. Make sure the proper gate is open.
- B. Partially blocked discharge; remove obstruction.
- C. Chain travel is too fast causing grain carry-over.

4. Unit not running to full capacity.

- A. Grain is high in moisture causing lower capacity. Excessive feeding of high moisture grain can cause plugging.
- B. Chain speed is too slow.
- C. Obstruction at intake.
- D. There is grain returning to the intake (See 3 above).

5. Paddle breaking or bending.

- A. Paddles may be coming loose from the chain. Keep paddles securely connected to chain.
- B. Housing misalignment.
- C. Frequent starts under loads. Allow machine to clean out before shutting down.
- D. Sprockets may be off center. Align in center of housing.
- E. Overfeeding; adjust the feeding of the unit to allow less grain to enter while maintaining full speed.

6. Unit stalled or plugged.

- A. A stall, plug, or stop under load may occur in spite of the operator's best efforts. A power failure, bin overfill, operator error, or mechanical or electrical breakdown could be the cause.
 1. Shut down the pump immediately and lockout the power source. Close the inlet(s) where grain was flowing into the system.
 2. Determine the cause by a visual inspection if you can.
 3. If the stall is due to a grain overload, remove the corner inspection door at the bottom of the vertical conveying up. Considerable grain will likely flow out. Remove the grain away from the pump corner, allow all the grain that will flow out to do so.
 4. Leave the corner inspection door off. With everyone clear of the pump, attempt restart. If the pump starts, more grain will push out of the door opening. If it does not start, lock out power source and look for other causes.

With the pump running, continue to operate until motor loads have reduced before shutting down. Once again, lockout power source before replacing inspection door.

B. Effects of a Stall or Plug

When the overload and stall are due to excessive grain amounts in the pump, the stall will usually occur when those excess amounts enter the vertical part of the system. As the pump approaches stall, the paddles at the lower corner of the vertical experience higher than normal loads due to the extra grain in that area and above.

Once stopped, grain higher in the vertical flows down through the paddle openings forming a solid pack of grain extending up to 80% of the vertical height. Restart in this condition is virtually impossible.

Restart attempted after only a portion of the vertical grain is drained away, or when the lower corner inspection door has been closed will cause high paddle loads that should be avoided.

INSTALLATION

The purpose of this section is to advise and instruct owners on how the equipment can be installed.

A millwright or other experienced contractor should perform the installation. **The installer should read this manual and understand the complete operation of the equipment.**

INSTALLATION INFORMATION

- All systems require the joining of four or more sections of tubular conveyor housing.
- All systems will include four 90° corners.
- The 90° discharge w/ gate includes either a 14'-6" (4.42 m) or 20 ft. (6.1 m) long section of conveyor tubing that must be fit within other conveyor tubing so the discharge can be located properly.
- The inlet dump hoppers include a length of tubular conveyor housing that must fit within other conveyor tubing so the hopper can be located properly.
- Wells used in grain bin floors fasten onto standard tubular conveyor housing. Access openings must be cut in the tubing to install wells.

LAYOUT

Grain Pump® Systems are usually installed around rows of storage structures, with access for vehicle or rail traffic and other devices.

Grain bins may be conventional or elevated on a supporting structure with hopper bottoms.

Grain dryers, cleaners or other devices may have access to the system.

Systems have been used to transfer between trucks and rail cars with several temporary storage tanks included.

The Grain Pump® conveyor can be used in many different ways and operation can vary from installation to installation.

Thought given to proper grain system layout prior to conveyor installation can prevent later problems in the grain flow plan and avoid possible "bottle-necks".

A layout should be made to determine the exact location of conveyor, inlets, outlets, power source, support and mounting locations.

The illustration on Page 16 shows some of the various components that can be used with your system. Consideration during the layout process should be given to their location if any of them are to be used in your application.

LAYOUT (con't.)

Dimensional information of components is found in the Parts List Section beginning on Page P-3.

IMPORTANT! If using the chain access assembly, it is required that it be installed on a horizontal section of the loop system.

LAYOUT CONSIDERATIONS

Following are major items that should be considered when laying out the system:

- A. Type of material to be conveyed.
- B. Volume of material to be conveyed [bushels (*tons*) per hour].
- C. Location and amount of material fed into system.
- D. Location and number of outlets.
- E. How will the conveyor be supported?
- F. Installation of a catwalk?
- G. Further expansion. Will more bins be added and where?
- H. The direction of grain flow.

Note: If two drive corners are used, the regular drive corner and the reversed driven corner can be switched to allow the belt guard (drive motor) to be on a particular side of the loop.

Use these general guidelines to help layout your conveyor system:

- Grain pumps are designed to move grain in one direction only.
- Leave adequate room to perform periodic maintenance.
- The conveyor will handle a wide range of free flowing grains. It should not be used with highly corrosive material, such as fertilizer. The life of the conveyor chain will be shortened when the chain is allowed to sit in water or is operated in acidic conditions, so avoid these situations.
- Be sure not to overfeed the conveyor. This will cause plugging. Intake rate should not exceed the particular capacity of the conveyor.
- It is important that a firm, level foundation or support structure be provided on which the conveyor can be mounted. This support should be ample to carry the load of the conveyor when fully loaded.
- Locate outlets where connecting bands will not interfere with outlets or control. **Do Not cut or modify tube connecting bands.**

LAYOUT INFORMATION

Location of Components shown as a reference only.

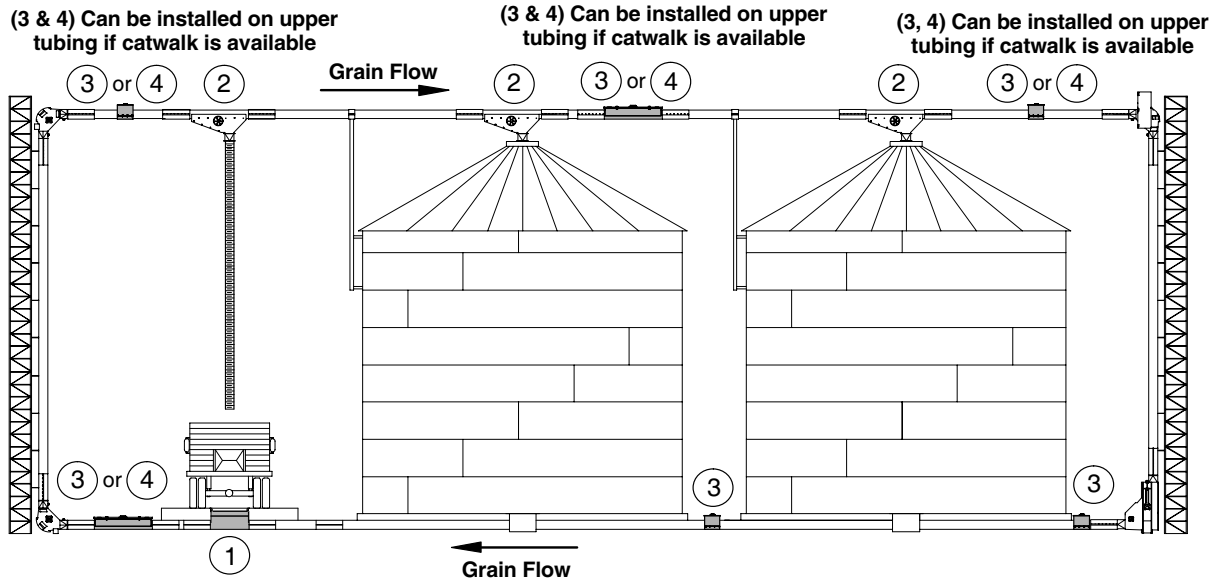

7 Grate Dump Hopper

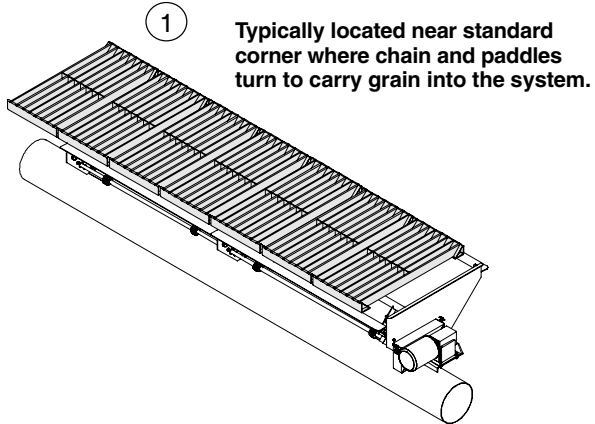

①

Typically located near standard corner where chain and paddles turn to carry grain into the system.

Drop Assembly

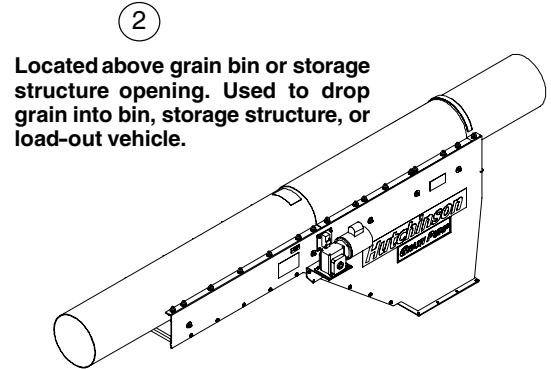

②

Located above grain bin or storage structure opening. Used to drop grain into bin, storage structure, or load-out vehicle.

Inspection Hopper

③

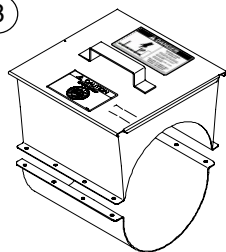

Generally installed after dump hopper or each bin. Can basically be installed anywhere along the horizontal tube of the loop system to view grain flow.

Chain Inspection Access (horizontal installation only)

④

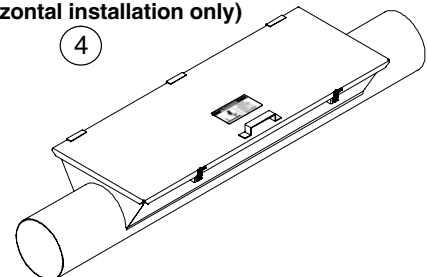

Typically located near standard corner after dump hopper, can also be installed in upper tubing if a catwalk is available.

ASSEMBLY INSTRUCTIONS

SYSTEM SUPPORT INFORMATION

Towers or other adequate supports are needed to hold the vertical ends of the Grain Pump® System in position. Consider the weight per foot (*meter*) of a fully loaded tubular conveyor, based on 56 lb. per bu. of material (*720 kg per cu. meter*), the individual corners and all other components, particularly the ones with drives which weigh considerably more.

The horizontal tubular conveyor should be supported at 20 ft. to 30 ft. (*6.10 to 9.14 m*) intervals. This can be done with vertical supports from the ground, from the bin side walls or from the bin roof at the peak. **Consult the bin manufacturer concerning their recommendations for loads their bin will support in these areas.**

Weight per foot (*meter*) of tubular conveyor:

Single Chain

Conveyor Tubing Empty - 46 lbs./ft. (*68.4 kg/m*)

Conveyor Tubing Fully Loaded - 133 lbs./ft. (*198 kg/m*)

GRAIN FLOW AND DRIVE CORNER LOCATION

Grain Pump® Loop Systems will include one or two drive corners. The drive corner, on systems with one (shown in the illustration below), must be located at the overhead point toward which the overhead chain will travel. On systems with two drive corners locate them at the two overhead positions.

The inspection corner includes the adjustable slide that is used to tighten the conveyor chain. Locate the inspection corner on the bottom at the end where the conveyor chain travels down from top to bottom. The inspection corner also provides access to the conveyor chain and paddles for periodic maintenance.

There will be one or two standard corners, depending on the number of drive corners. They will be located at the end where the conveyor chain moves up carrying grain from the bottom to the top. When there are two drives, there is only one standard corner located at the bottom.

The system should be laid out to minimize the distance grain must be moved to perform the necessary loading and unloading operation. In the example, the dump hopper is located next to the end where the grain will be carried up to the overhead part of the system. If the dump hopper were located at the other end of the system the grain must travel a greater distance in the system to reach a bin. Grain would also travel a greater distance to the load out point when unloading bins.

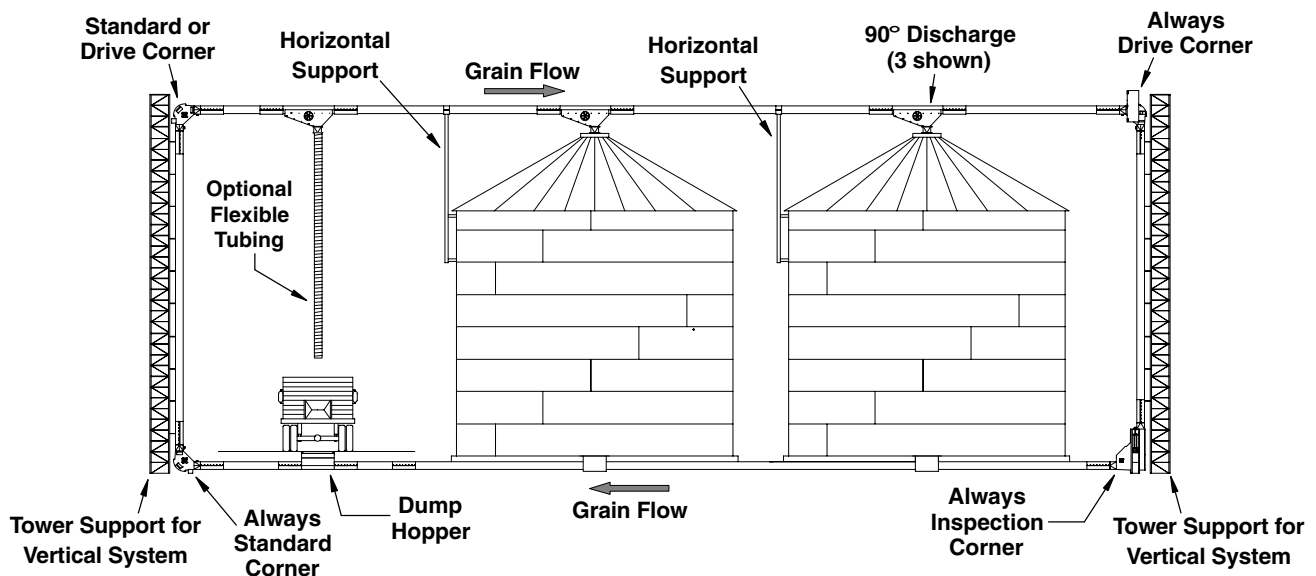

TUBE AND CORNER ASSEMBLY

Lay the tubing and corner sections out in order so as to determine what portions to assemble prior to actual placement in the system.

When cutting tubes to exact length, the ends must be cut square and any burrs on the ends removed. Attach flanged tubes to corner assembly with 3/8" x 1" bolts and nylon locknuts. Join flanged tubes and conveyor tubing together with connecting bands (slide the tube sections tight together). Tighten the 3/8" x 1 1/2" bolts and nylon locknuts in the connecting bands.

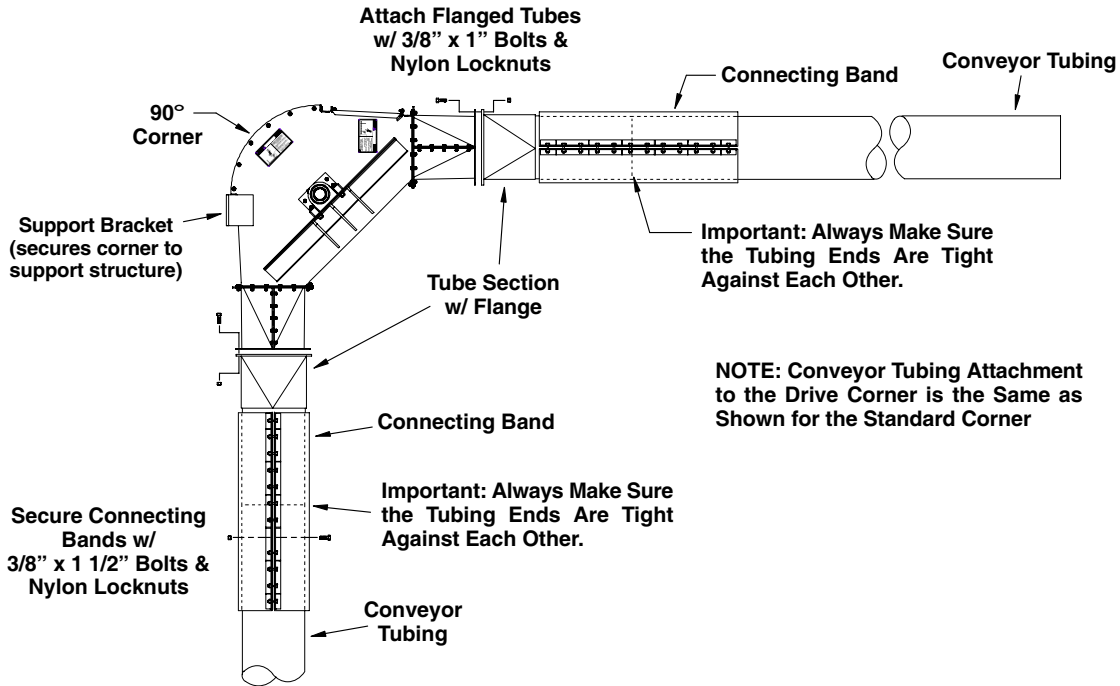

DISCHARGE WITH GATE ASSEMBLY

The discharge unit includes either a 14'-6" ft. or 20 ft. (4.42 m or 6.10 m) long section of conveyor tube. Locate the outlet of the discharge in the desired location. It may be necessary to cut exact lengths of other tube conveyor sections to locate the discharge unit in its proper place.

The discharge with gate is designed for chain travel through in only one direction. Make sure it is oriented properly by comparing the appearance to the diagram or referring to a label on the discharge unit. Operation in the wrong direction can cause paddle damage.

Fasten the discharge in place within the tubular conveyor with connecting bands. Secure using 3/8" x 1 1/2" bolts and nylon locknuts.

If gate does not travel smoothly, it can be adjusted by loosening the bolts on the side rails and adjusting the top bolts on the flat bar (See Steps 2 & 6 on the following page).

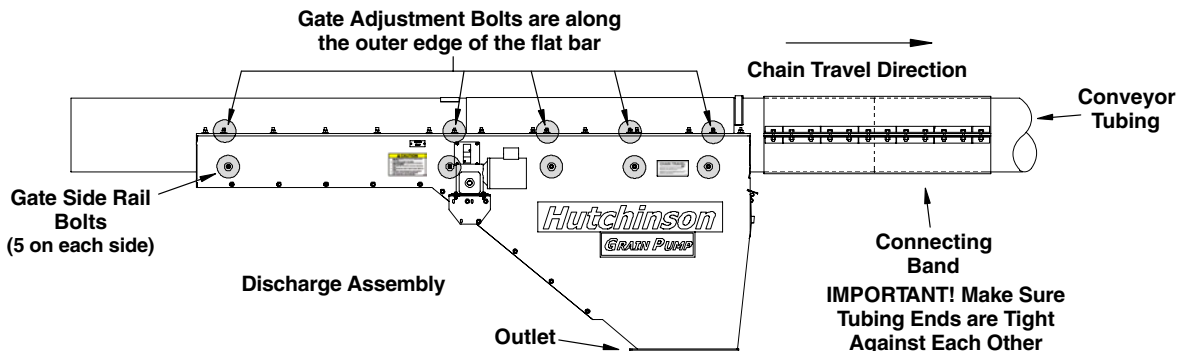

INLET DUMP HOPPER INSTALLATION

The conveyor tube length on the dump hopper is 16' (4.88 m) long. A set of seven (7) drive-over grates are also included with the dump hopper.

Grain flow control is achieved with the use of control gates operated by an electric motor. The instructions for the electric motor connection are included with the motor and requires installation by a qualified electrician.

A dump hopper is to receive grain into the Grain Pump® Loop System and should be located at a point along the bottom conveyor portion. Usually the dump hoppers are located near the standard corner where the chain and paddles turn to carry grain up into the system (See illustration below).

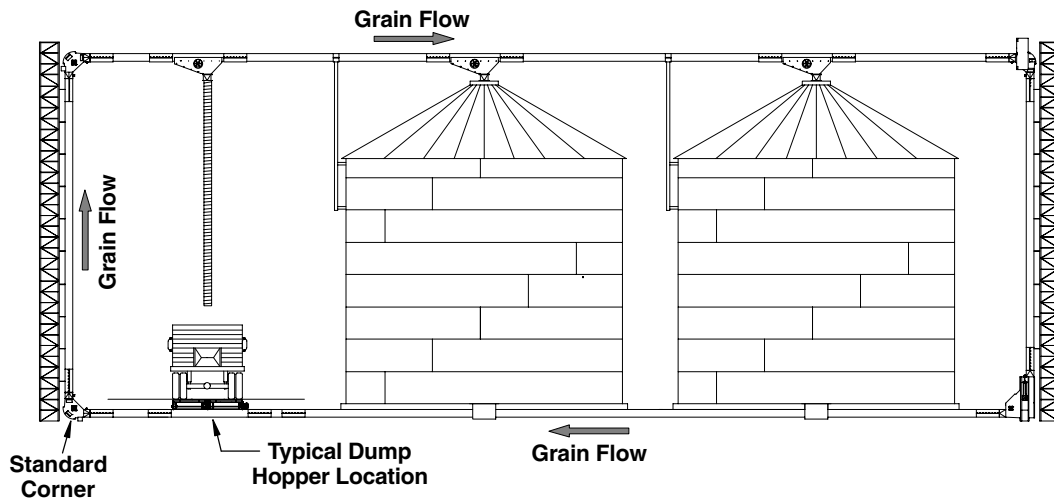

Make sure the drive over grating is in place on the hopper at all times.

For drive-over systems the grate must be supported by a concrete structure, such as shown below. Even if the dump hopper is not used for a drive-over system, it will still need some type of support structure.

Once the location of the dump hopper has been determined and properly installed, attach the hopper to the loop system conveyor tubes using the connecting bands provided.

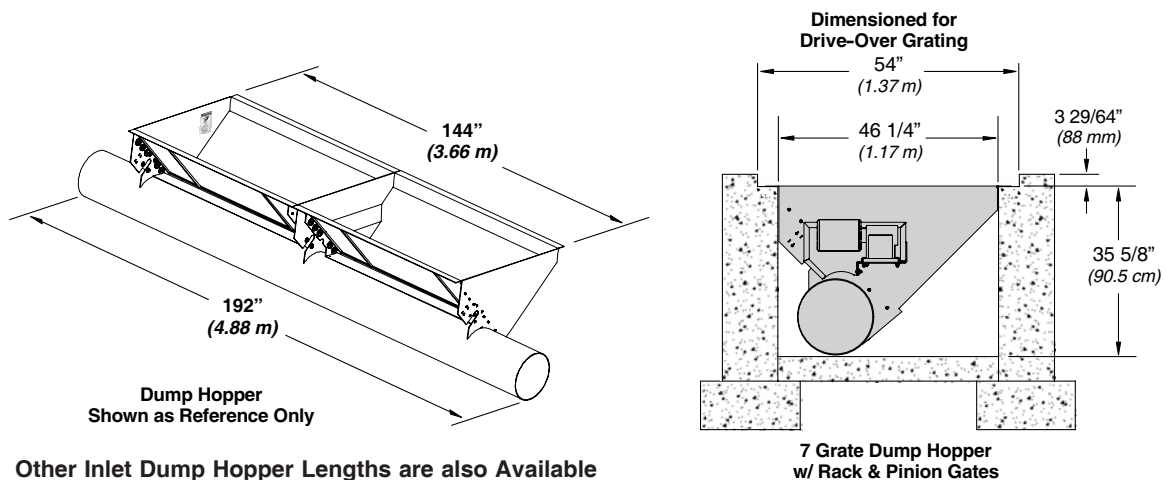

Other Inlet Dump Hopper Lengths are also Available

ASSEMBLY INSTRUCTIONS

AUTO TAKE-UP CORNER ASSEMBLY (STANDARD)



CAUTION! Do Not operate the conveyor when the inspection door or access doors are open. Make sure the lock-out pin is in place when the carriage is in its full raised position.

After the location for the inspection corner assembly has been determined, attach the flanged tube sections to the inspection corner using 3/8" x 1" bolts and nylon locknuts. Secure the flanged tubes to the conveyor tubing using the connecting bands and 3/8" x 1 1/2" bolts and nylon locknuts provided (See illustration below).

1. Install the winch onto the mounting bracket located on the inside face of the corner assembly. Secure the winch using three (3) 3/8" x 1" bolts, two (2) flat washers and nylon locknuts. Attach the winch handle to the winch.
2. Mount the weights onto the auto take-up carriage. Place a single weight on one side, then another weight on the opposite side. Repeat until all eight weights have been placed onto the carriage. To keep the weights from sliding off, install a 3/8" x 1 1/2" bolt and nylon locknut onto each end of the take-up carriage.
3. Fasten the pulley bracket onto the vertical tube above the auto take-up weights as shown below. Position the pulley bracket approximately 34" (86.4 cm) above the flanged tubing's connecting point. Secure the bracket to the tube using one half-band and six (6) 3/8" x 1 1/2" bolts and non-lock nuts.
4. Assemble the pulley using the provided pulley wheel, side plates, bushing and 1/2" x 2" bolt and nylon locknut. Hang the pulley assembly from the pulley bracket mount tabs and secure with one (1) 1/2" x 2 1/2" bolt and nylon locknut.

5. Attach the lift cable to the winch drum as shown below. Wind the cable onto the drum so that the cable wraps around the drum three times (cable should wrap from the bottom of the drum when the handle is turned in a clockwise direction).
Secure cable to side of drum using the cable keeper as shown below.

6. Route the loose end of the cable up and around the pulley previously installed. Attach the cable hook to the end of the cable and secure hook using the two cable clamps provided (make sure the u-bolt portion of the clamps are against the loose end of the cable).
7. Connect the hook to the top of the take-up carriage. Check that the take-up carriage travels through its entire range of motion as the winch is being operated (when the carriage is in its full raised position, a lockout pin will be inserted through the slide plate to support the carriage whenever servicing the unit is required).

IMPORTANT! When the weights and take-up carriage are in the full down position, there needs to be some slack in the winch cable. This allows the tension sprocket to provide proper pressure on the chain. Refer to Page 10 for chain tension procedures.

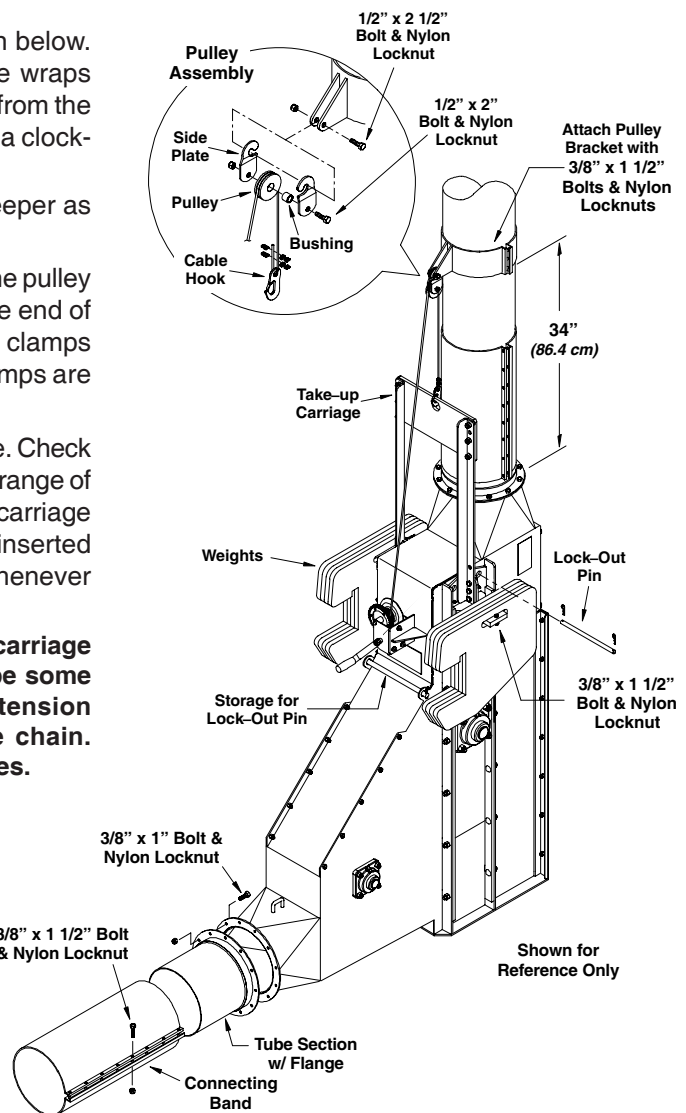
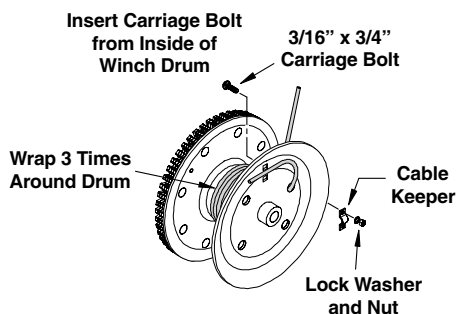

DRIVE CORNER



WARNING! Whenever you must service or adjust the equipment, make sure to stop the motor and lock-out the power source.



A main disconnect switch capable of being locked in only the “Off” position shall be used. This shall be locked whenever work is being done to the conveyor.

The Commercial Grain Pump® Loop System is powered by an electric motor. Always use a motor with required horsepower (*kw*) as calculated on Page 7. Use a 60 hz motor that operates at 1750 RPM (*50 hz @ 1460 RPM*). Also see “Electric Motor Drive Information” and Lockout procedures on Pages 8 & 9 in this manual. **For 50 hz motors, different drive pulleys are required, consult factory for proper specifications.**

Electrical motors and controls must be installed by a qualified electrician and must meet the standards set by the National Electrical Code and all state and local codes.

IMPORTANT! Use the motor sheave that is furnished with the conveyor system. If a different size sheave is used or substituted, improper chain speed will result causing unsatisfactory conveyor operation.

Use the proper size and speed motor to ensure the conveyor operates effectively and efficiently. Too small a motor will not supply the horsepower (*kw*) required to achieve capacity and possible damage to the motor can occur.

Too large of a motor may cause high stress on the conveyor components resulting in shorter life for these components. Refer to Page 7 for information on calculating correct motor size.

If two drive corners are used, the regular drive corner and the reversed drive corner can be switched to allow the belt guard (drive motor) to be on a particular side of the loop.

1. Attach the flanged tube sections to the drive corner using 3/8” x 1” bolts and nylon locknuts. Connect the drive corner and flange tubes to the conveyor tubes using the connecting bands and 3/8” x 1 1/2” bolts and nylon locknuts provided.
2. Install the cooling fan (if provided) to the reducer shaft using the instructions provided with the cooling fan.
3. Mount the belt guard according to the instructions provided with the belt guard and drive components. When mounting the sheaves to either the motor shaft or reducer shaft do the following:

Install the bushing onto the shaft first, then slide the sheave onto the bushing (the bushing will be on the inside).

Install the driven sheave as close to the back of the belt guard as possible. Align sheaves by using a straight edge placed across the face of both sheaves. Secure sheaves into place.

Install the drive belts to the sheaves and set belt tension. To tighten belts, turn the 3/4” nuts on the motor mount bolts until belt tension has been achieved (proper belt tension is approx. 1/2” (13mm) of deflection when belts are firmly pressed in the center of the span between the two sheaves).

IMPORTANT! The gear reducer is shipped without oil. It is necessary to add oil before unit operation. Refer to Page 14 for procedures on adding oil and the proper grade of oil to be used.

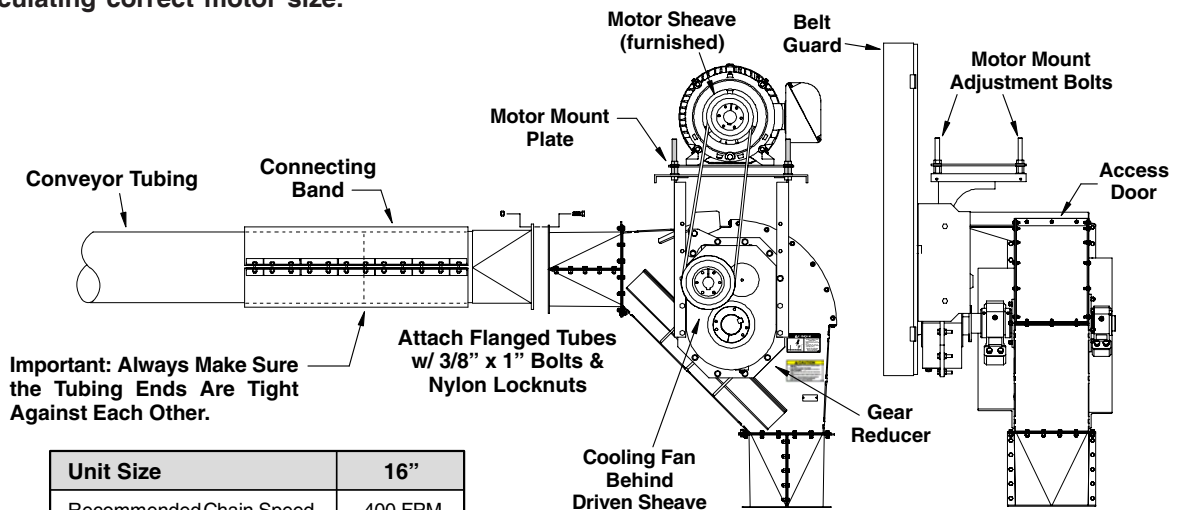

Unit Size	16”
Recommended Chain Speed	400 FPM (121.92 MPM)
Corner Shaft RPM	63 RPM

ASSEMBLY INSTRUCTIONS

CHAIN & PADDLE ASSEMBLY



CAUTION! The areas around the chain sprockets can create pinch points causing personal injury. Use caution when working around these areas.



The take-up carriage is provided with a lock-out pin. To avoid serious injury, Do Not attempt to access or service the chain, paddles or other parts within the inspection corner without the lock-out pin in place.

Note: Some units may be shipped with the paddles already attached to the chain. If your unit already has the paddles attached, continue with Step 2 below.

If the paddles have not been installed, begin with Step 1 below.

1. Install the paddles so that the paddle mounting brackets are behind the paddles as grain is being moved through the conveyor tubes.

For **WH-124 chain**, attach each paddle to the mounting brackets with four (4) 3/8" x 1 1/2" bolts, four (4) flat washers (on paddle side) and four (4) nylon locknuts. Make sure a paddle is attached to every mounting bracket along the entire length of chain.

There is an optional rubber clean-out that can be used with the paddles. Attach the clean-out to the paddle using two (2) 3/8" x 2" bolts, four (4) flat washers and two nylon locknuts.

Secure rubber clean-out and paddle to chain brackets using four (4) 3/8" x 2" bolts, four (4) flat washers and four (4) nylon locknuts (See illustration below).

2. It will be necessary to use an electrical fish tape, wire, or rope to pull the chain through the conveyor tube sections. It is recommended to begin and end at the take-up inspection corner, as this will be where the chain's tension will be determined.

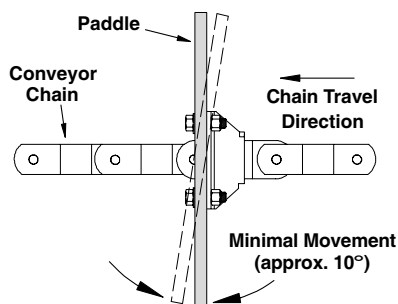

3. Using the winch, raise the take-up carriage and weights high enough to **insert the lock-out pin** through the slide plates to support the raised take-up carriage.

IMPORTANT! On long horizontal runs it is possible for the chain to rotate 360° during the pull-through between corners. Use inspection doors discharge gates and openings in bin wells to observe the chain position along the length of the conveyor sections.

After the chain and paddles have been installed through the conveyor housing and around all corner sprockets, connect the ends of the chains together at the take-up inspection corner using the connecting and keeper pins provided. **IMPORTANT: The end of the keeper pin must be flattened/peened to hold in place.**

Once the chain ends have been connected together, slowly lower the take-up carriage aligning the sprocket and the chain. Continue lowering the carriage until sprocket is down as far as it can go.

For **auto take-up** corners, the full weight of the carriage will be resting on the chain and there should be a bit of slack in the winch lift cable (**if the lift cable is tight during operation, proper chain tension will not be maintained**).

To check chain tension, grasp one of the paddles and attempt to rotate it towards the chain. Proper tension should allow only minimal movement of the paddle.

If there is more movement than recommended and all weight is resting on the chain, it may be necessary to remove more links from the chain (**if less tension is desired, remove weights in pairs, one from each side until desired tension is achieved**).

Another indication of **proper chain tension** is whether the traction wheel shaft is turning while the loop system is running. See Page 10 in the Maintenance Section for information on this procedure.

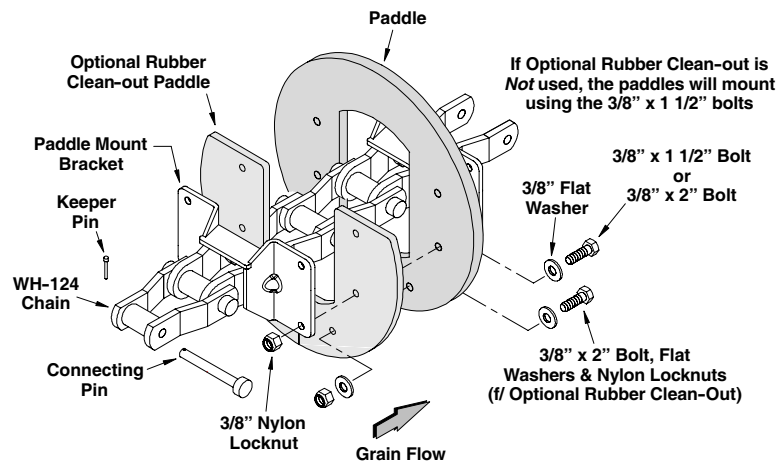

DISCHARGE SPOUT with CABLE GROUND CONTROL GATES



CAUTION! Metal parts may have sharp edges and can create flying debris when filed, cut or drilled. Use proper safety equipment such as gloves, eye protection and hearing protection when working with metal materials.



Use caution when working in areas above the ground. Use fall protection equipment and follow applicable OSHA guidelines and regulations.



Metal buildings, scaffolding and other types of work surfaces can become slippery, especially when surfaces are wet and/or oily. This can create hazardous working conditions. Use caution when working, climbing or walking on these surfaces.

The location of the discharge controls and routing of the control cables (or ropes) should have been determined before ordering the Grain Pump® Loop System.

The discharge gate controls must be located in line with the conveyor tube so the control cable, or rope will track properly on the control wheels.

The cable, or rope should be one continuous length. If splicing is necessary, splice the ends together with cable clamps. Plan where the splice(s) in the control cable, or rope are to be located. Avoid splicing where the splice will be pulled onto a control wheel or through a pulley while the gate is being opened or closed.

The wall brackets are designed to be mounted directly to the grain bin wall. Locate the control wheel about 5' off the ground (or at a height that is easy and convenient to reach). Locate the upper wall bracket (with pulleys) at the top of the bin wall so the control cable, or rope will clear the eave of the roof or other hanging structures.

The ground control wheel can be mounted to the same bin that the discharge spout is attached to (See Example 1), or the ground control wheel can be mounted to an adjacent bin (Example 2).

Refer to the following page, Page 26, for assembly procedures of the wall brackets, pulleys and cable control wheels.

The control cable, or rope must be anchored to both the upper and lower wheels to provide positive control and to prevent the cable or rope, from slipping on the control wheels.

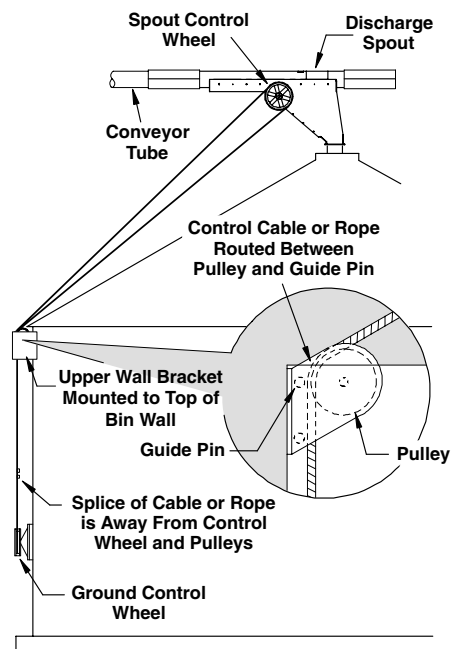

Example 1
Controls Mounted on Bin
Where Spout is Located
(pulley mounted on inside of bracket)

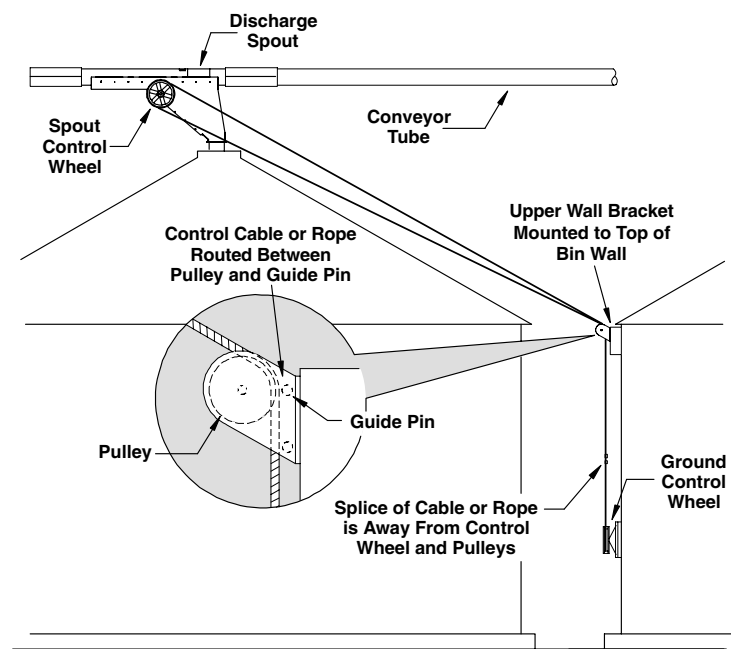

Example 2
Controls Mounted
on Adjacent Bin
(pulley mounted on outside of bracket)

***DISCHARGE SPOUT with CABLE
GROUND CONTROL GATES (con't.)***

The upper wall bracket and the ground control wall plate are designed to be mounted directly to the grain bin wall. Use the existing hardware from bin wall to fasten the bracket and plate to the bin.

1. Attach the two pulleys to the upper wall bracket using four (4) 1/4" x 3/4" bolts and nylon locknuts for each pulley. **Note: Mount the pulleys so both of them are either on the inside or on the outside of the wall bracket.**
 - A. If the controls are mounted on the same bin that the discharge spout is attached to, mount the pulleys on the inside of the wall bracket (See Example 1 on Page 25 and illustration below).
 - B. If the controls are mounted to an adjacent bin, mount the pulleys on the outside of the wall bracket (See Example 2 on Page 25 and the illustration below).
2. Locate the wall bracket and pulleys so they are in line with the discharge spout control wheel (this will allow the cable, or rope to properly track onto the spout control wheel). Attach the wall bracket to the top of the bin wall in a position that allows the cable, or rope to clear the eave of the bin.

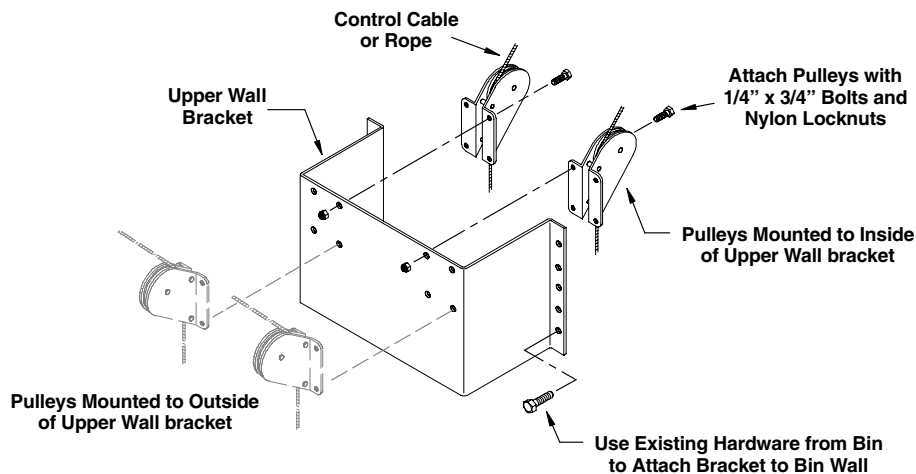

3. Attach each wall plate to the wheel bracket as shown below. Secure the brackets using two (2) 3/8" x 1" bolts, four (4) flat washers, and two (2) nylon locknuts (be sure to use a flat washer over each slot). Slide the wheel bracket up so the bolts are at the bottom of the wheel bracket slots, but at the top of the wall plate slots.
4. Determine the location of the ground control wheel and attach the wall plates to the bin wall (use the existing hardware from the bin to mount the plates).
5. Slide a 1" flat washer over the shaft on the wheel bracket and install the control wheel. Slide another 1" flat washer onto the shaft and secure using a 3/16" x 1 3/4" cotter pin.

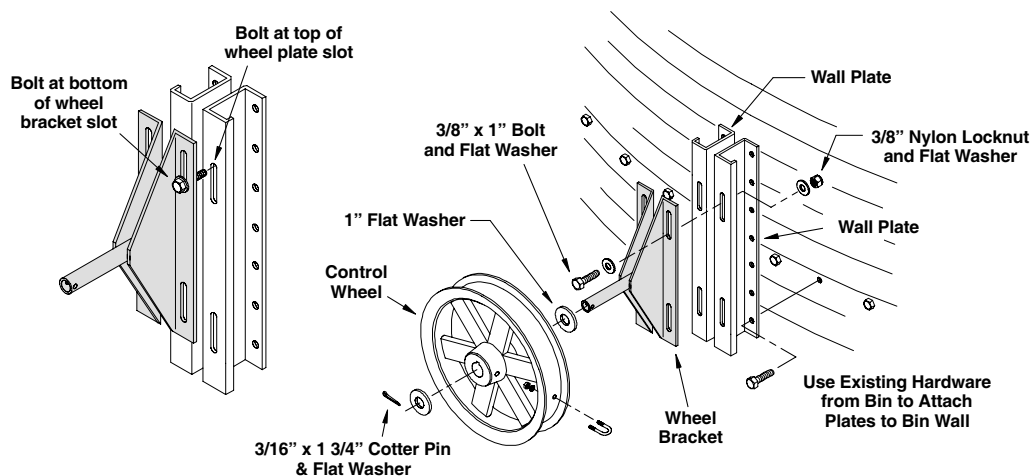

DISCHARGE SPOUT with CHAIN GROUND CONTROL GATES



CAUTION! Metal parts may have sharp edges and can create flying debris when filed, cut or drilled. Use proper safety equipment such as gloves, eye protection and hearing protection when working with metal materials.



Use caution when working in areas above the ground. Persons working on equipment that requires above ground work shall be properly secured with the use of “fall protection” equipment as set forth by OSHA guidelines and regulations.



Metal buildings, scaffolding and other types of work surfaces can become slippery, especially when surfaces are wet and/or oily. This can create hazardous working conditions. Use caution when climbing, walking or working on these of surfaces.

The location of the discharge controls and routing of the control chains should have been determined before ordering the Grain Pump® Loop System.

The discharge gate controls must be located in-line with the conveyor tube so that the control chain will track properly on the control sprockets.

The chain should be one continuous length having only one splice. Plan where the splice(s) in the chain will be located (**the splice needs to be located so it cannot be pulled onto the sprocket wheel**).

Although a chain is furnished with the kit, it does not mean the length provided will be long enough for your application. If additional chain is needed and requires more than one splice, make sure to locate the additional splice in the same manner.

The upper wall bracket and the ground control wall plate were designed to be mounted directly to the grain bin wall. Use the existing hardware from the bin wall to attach the bracket and plate to the bin.

The lower chain mount can be mounted to the same bin that the discharge spout is attached to, or it can be mounted to an adjacent bin (See Examples 3 & 4 below). Whichever method is used, both rollers need to be mounted either on the inside or on the outside of the wall bracket.

Locate the lower chain mount about 2' to 3' (61.0 cm to 61.4 cm) off the ground (or at a height that is easy and convenient in order to reach the chain above the lower chain mount).

Locate the upper wall bracket (with rollers) at the top of the bin wall so the control chain will clear the eave of the roof or other hanging structures.

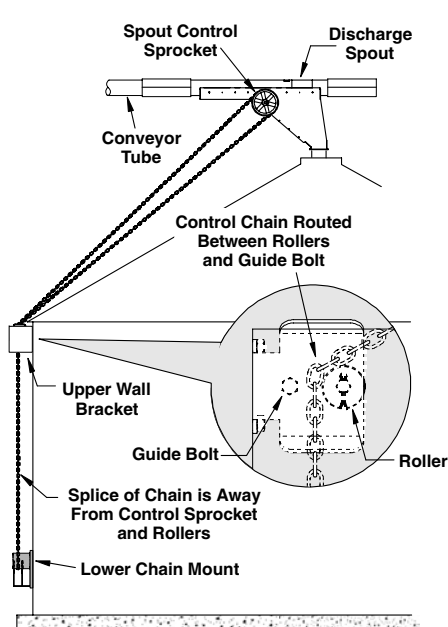

Example 3
Controls Mounted on Bin
Where Spout is Located
(rollers mounted on inside of bracket)

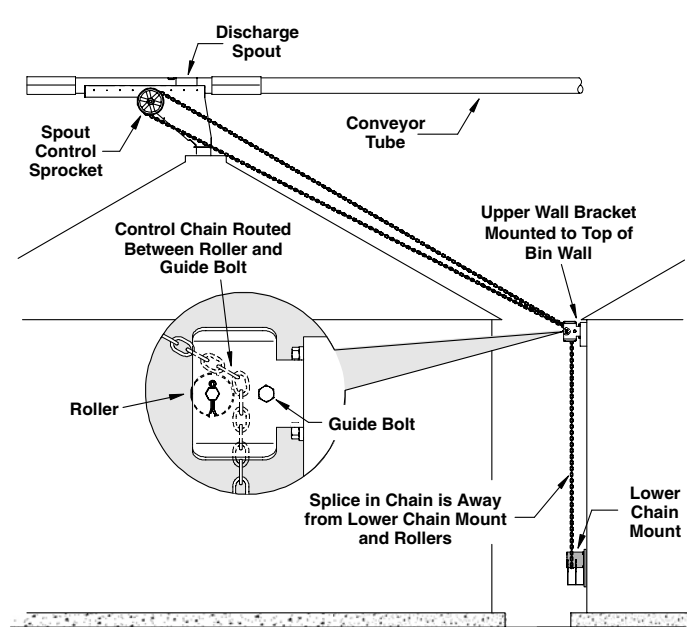

Example 4
Controls Mounted
on Adjacent Bin
(rollers mounted on outside of bracket)

ASSEMBLY INSTRUCTIONS

DISCHARGE SPOUT with CHAIN **GROUND CONTROL GATES (con't.)**

Install Chain Ground Control Components

1. Install the spout control sprocket onto spout shaft as shown below. Install the bushing onto the shaft using the 1/4" sq. x 3" long key and tighten setscrews to secure bushing to shaft. Attach the sprocket to the bushing using the bolts provided with the sprocket.

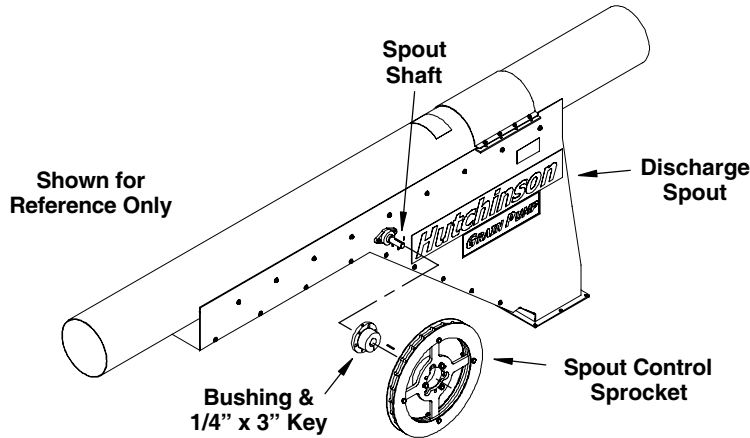

2. Attach the two rollers to the upper wall bracket using four (4) 3/8" x 1" bolts and nylon locknuts for each pulley (See illustration below).
 - If the controls are mounted on the same bin that the discharge spout is attached to, mount the pulleys on the inside of the wall bracket as shown in Example 3 on Page 27.
 - If the controls are mounted to an adjacent bin, mount the pulleys on the outside of the wall bracket as shown in Example 4 on Page 27.
3. Locate the wall bracket and rollers so they are in-line with the discharge spout control sprocket (this will allow the chain to track properly onto the spout control sprocket). Attach the wall bracket to the top of the bin wall in a position that allows the chain to clear the eave of the roof.

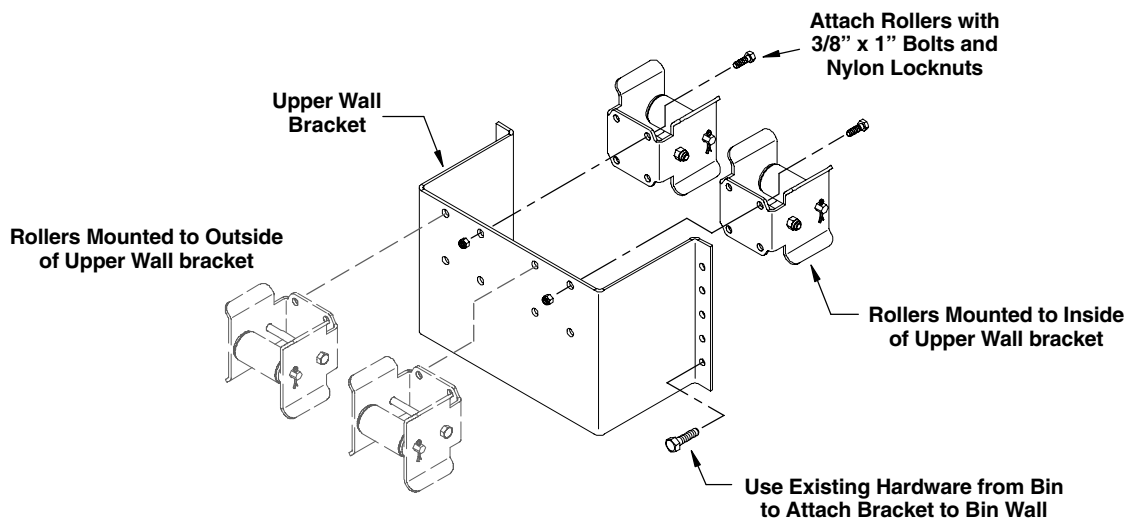

Install Chain Ground Control Components (con't.)

4. Attach each wall plate to the lower chain mount as shown in the illustration below. Secure each bracket using two (2) 3/8" x 1" bolts, four (4) flat washers and two (2) nylon locknuts. Slide the chain mount up so the bolts are at the bottom of the chain mount slots, but at the top of the wall plate slots (See illustration below).
5. Determine the location of the lower chain mount and attach the wall plates to the bin wall (use the existing hardware from the bin to mount the wall plates).
The bottom of the wall plates should be approximately 2' to 3' (61.0 cm to 91.4 cm) off the ground.

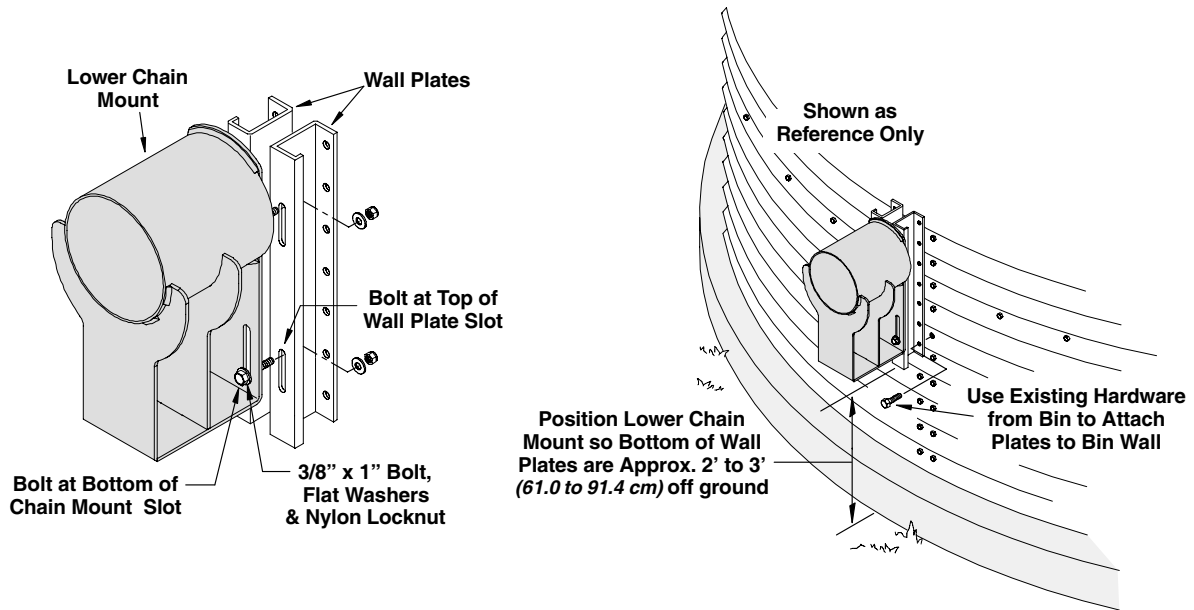

6. Route the control chain through one of the rollers on the wall bracket and up to the discharge spout control sprocket (make sure the chain is positioned between the roller and the guide bolt). **The chain can be clamped to the wall bracket to keep it from slipping through the bracket and roller while it is being routed up and around the control sprocket.**
 - Leave a good portion of the chain hanging below the roller on the wall bracket. This will be the end of the chain that will be spliced [this location is only a reference, it does not mean the splice has to be at this location. Just keep in mind that the splice (splices if more than one chain is used) need to be far enough away so it cannot be pulled onto the control sprocket.
7. Route the chain down and behind the remaining roller on the wall bracket and down to the lower chain mount (make sure the chain is engaged with the teeth on the sprocket).
Keeping the chain fairly taut, route the end of the chain to the portion of chain left hanging below the wall bracket roller. Connect the two ends of chain together using one (1) 3/16" threaded chain coupler. **The lower chain mount has adjustment slots to tighten the chain after it has been installed. If you determine that the chain is still too long, even after this adjustment has been made, cut off the excess chain length and then connect the ends together with the threaded coupler.**

ASSEMBLY INSTRUCTIONS

Install Chain Ground Control Components (con't.)

- Loosen the bolts securing the lower chain mount to the wall plates. Slide the chain mount down to tighten the chain. Retighten the bolts securing the lower chain mount into place.

Note: 120' (36.58 m) of chain is included with this kit. If more chain is required for your application, keep in mind that the splices cannot be pulled onto the control sprocket. Determine splice locations accordingly.

Operation Notes:

The controls should be clearly marked as to which spout they control to prevent accidentally discharging grain into the wrong bin.

Controls should be marked to indicate when a spout is open or closed.

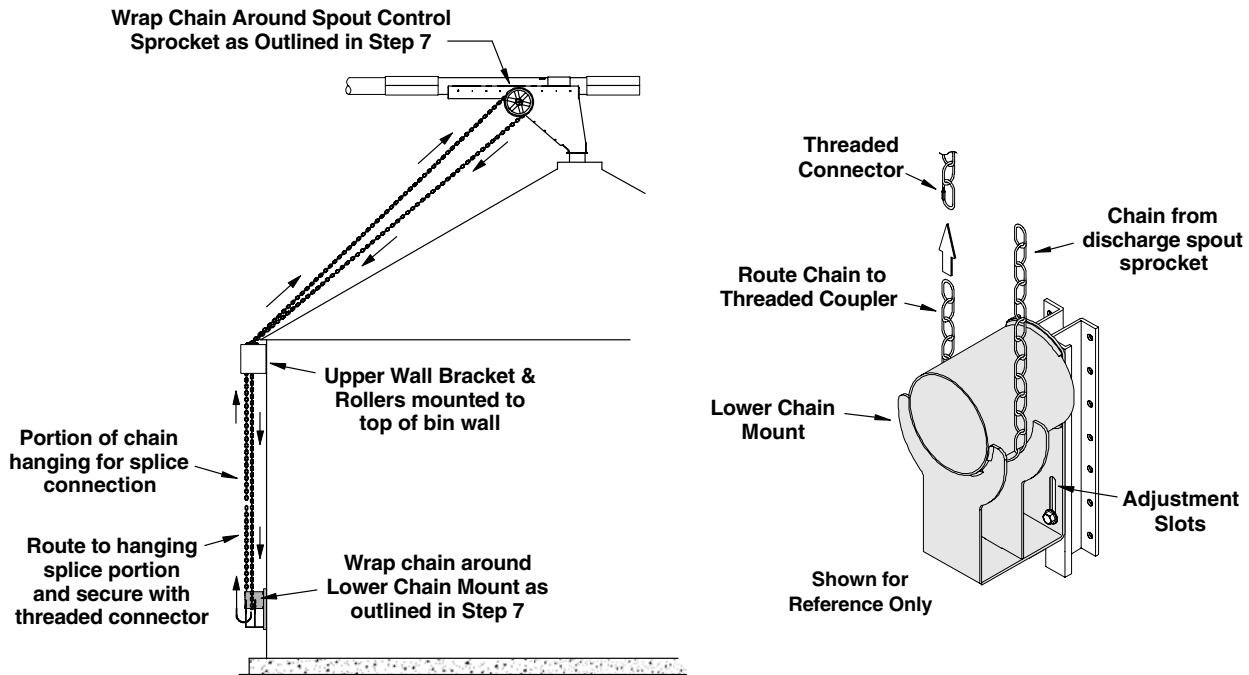

INSPECTION PORTS

Inspection ports can be used within the loop system for various applications. They can be positioned in the conveyor system as extra inspection doors, or can be used in hard-to-reach places for clean-out purposes.

Typically these inspection ports are located in areas where the operator can visually inspect the flow of grain passing through the loop system, and installed along any section of horizontal tubing.

1. After location for the inspection port has been determined, remove the cover and safety screen from the inspection port hopper.

Place the inspection port on top of the conveyor tube and mark the conveyor tube from the inside of the hopper, leaving a minimum of 1/2" (13 mm) of tubing around all four sides of the hopper (See illustration below).

2. Verify the marks do not extend past the sides of the inspection port hopper (grain will leak out of the hopper if the opening is too large).
3. Cut and remove the section of conveyor tube previously marked, making sure to remove all pieces of cut material from inside the tube. Ensure cut edges of tubing are filed smooth so as not to cause interference with the paddles.

Note: Do Not cut openings in the conveyor tube when the chain and paddles are inside the tube. Damage to the chain and/or paddles can occur.

4. Secure the inspection hopper to the conveyor tube using the back band and 5/16" x 1 1/2" bolts and non-lock nuts provided.

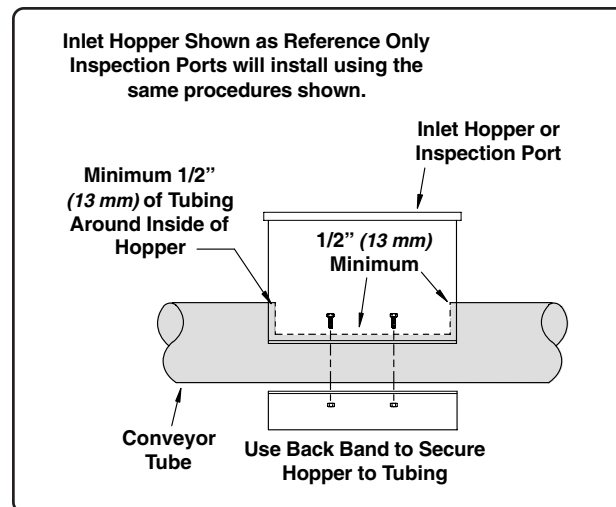

Fig. 12

ASSEMBLY INSTRUCTIONS

CHAIN MAINTENANCE ACCESS

HOPPER

Chain maintenance access sections are available for use on the horizontal tubes only.

The access sections are typically installed between the drive-over pit and first corner section, but can be installed anywhere in the loop system as long as they are installed on the horizontal tubes.

Dimensions for the chain maintenance access hopper can be found in the parts list on Page P-14.

1. After location for the access section(s) has been determined, connect to the conveyor system tubes using the connecting bands provided. Tighten connecting bands as shown in Fig. 14.

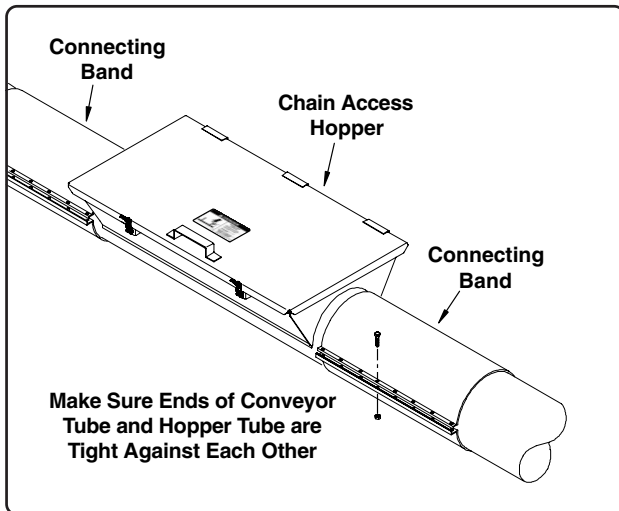

Fig. 13

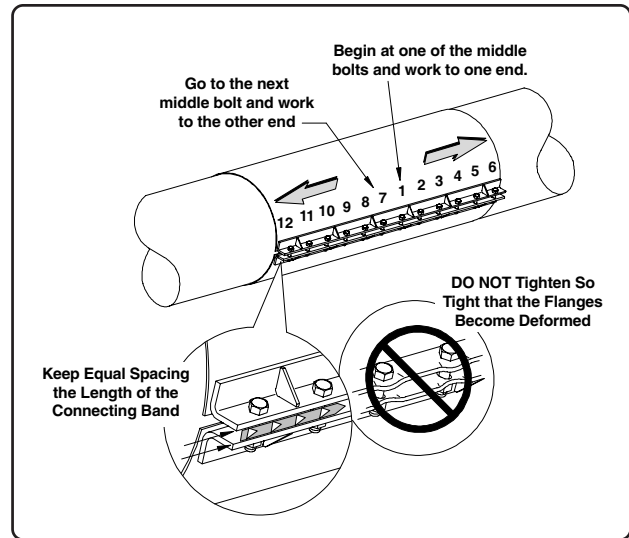

Fig. 14

16" Commercial Grain Pump Loop System

<i>Decals and Safety Signs</i>	<i>P-2 to P-3</i>
<i>Auto Take-Up Inspection Corner</i>	<i>P-4 to P-5</i>
<i>Drive Corner, 100 hp</i>	<i>P-6 to P-7</i>
<i>Drive Corner, 125 hp</i>	<i>P-8</i>
<i>Standard Corner, 100 hp and 125 hp</i>	<i>P-9</i>
<i>90° Discharge Assembly, w/ Gate</i>	<i>P-10</i>
<i>Chain & Paddle Assembly</i>	<i>P-11</i>
<i>Ground Control Wheel (w/ Chain)</i>	<i>P-11</i>
<i>Ground Control Wheel (w/ Cable)</i>	<i>P-12</i>
<i>Inspection Port</i>	<i>P-12</i>
<i>Dump Hopper, 7-Grate w/ Electric Rack & Pinion Gates</i>	<i>P-13</i>
<i>Flat Storage Well w/ Electric Slide Gate</i>	<i>P-14</i>
<i>Chain Maintenance Access Assembly</i>	<i>P-15</i>

PARTS LIST

SAFETY SIGNS and DECALS



Ref. No.	Part No.	Description	Ref. No.	Part No.	Description
1	1002310	Danger, Do Not Operate with Cover Open	5	1033033	Caution, Grain Pump Loop Fill
2	1012872	Danger, Moving Chain Hazard	6	1001128	Decal, Hutchinson Globe
3	1002301	Caution, General Statement	7	1001127	Decal, Hutchinson (rectangle)
4	1012785	Decal, Chain Travel	8	1041833	Decal, Made in America
			9	34349	Decal, Grain Pump

SAFETY DECAL LOCATIONS on SYSTEM COMPONENTS

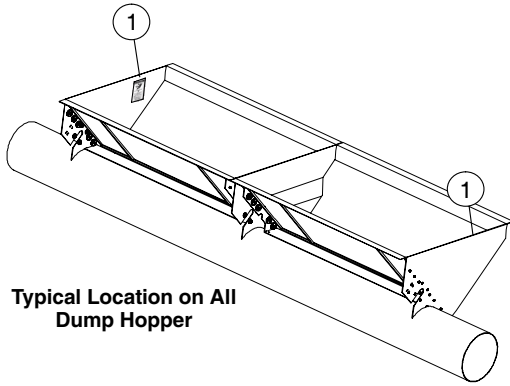

Typical Location on All
Dump Hopper

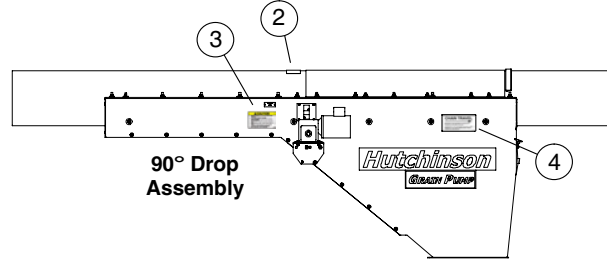

90° Drop
Assembly

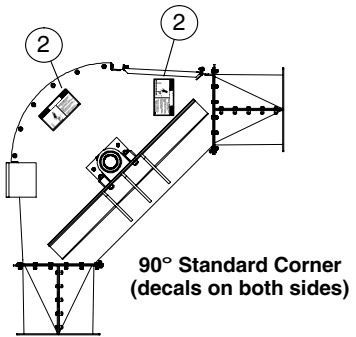

90° Standard Corner
(decals on both sides)

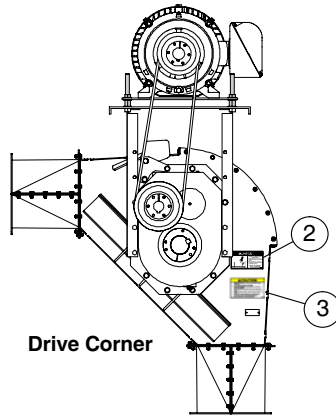

Drive Corner

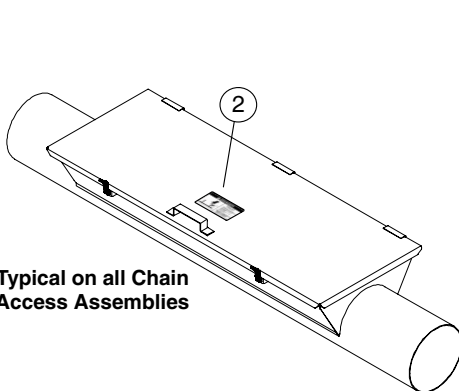

Typical on all Chain
Access Assemblies

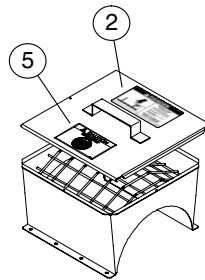

Inspection Ports

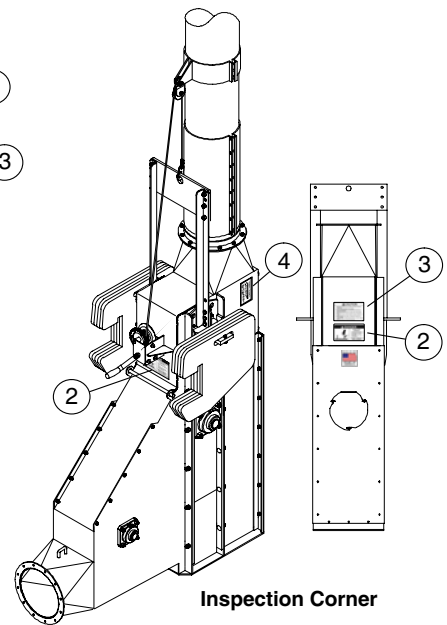

Inspection Corner

PARTS LIST

AUTO TAKE-UP CORNER ASSEMBLY **(INSPECTION CORNER)**

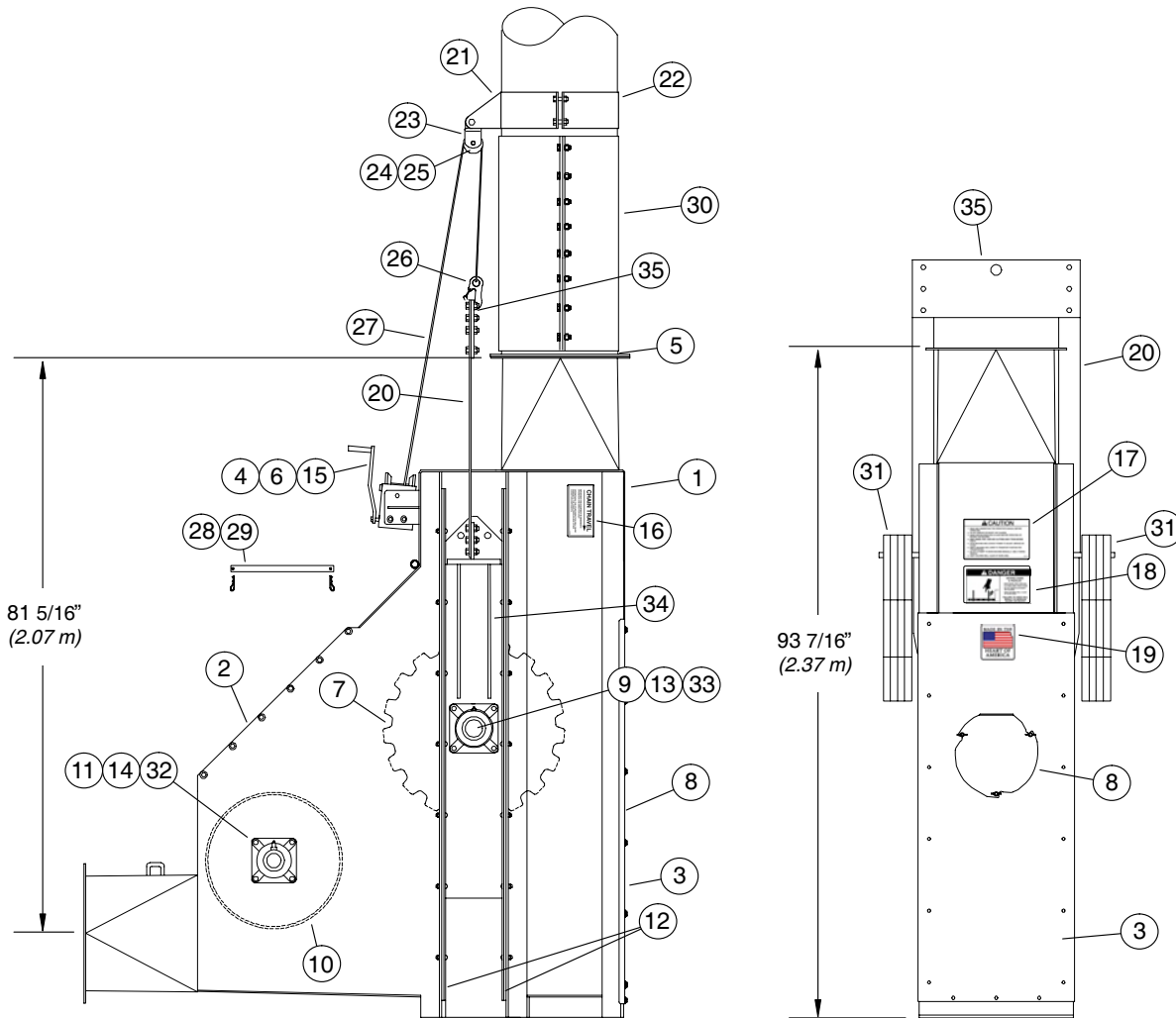
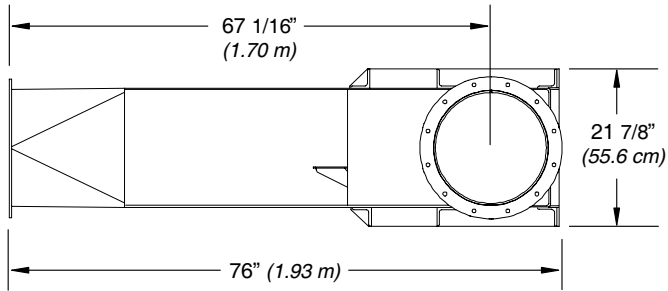

PARTS LIST

AUTO TAKE-UP CORNER ASSEMBLY (INSPECTION CORNER)

Ref. No.	Part No.	Description	Ref. No.	Part No.	Description
1	1025650	Auto Take-Up Corner Weldment	19	1041833	Decal, Made in America
2	1025654	Cover, Inside Panel	20	1025652	Strap, Slide Lift
3	1025655	Inspection Door (rear)	21	1025268	Bracket Weldment, Pulley
4	3335A1	Winch Assembly, K1550	22	1025708	Half-Band, 16" x 8" Wide
5	1035961	Tube Section, 16" x 26 1/8 long	23	1007890	Cable Pulley Side
6	41595	Handle, Winch f/ K1550	24	1008195	Pulley, Cable, 1/4" x 3" O.D.
7	1025659	Sprocket, 19 tooth	25	50079A1	Bushing, 1" O.D. x 5/8" long
8	1023397	Cover, Peek Hole	26	106411	Hook w/ Safety Clip
9	1017183	Shaft, Inspection Corner	27	1011852	Cable, 1/4" dia. x 19'-0" long
10	1017009	Wheel, Traction	28	1025751	Bar, Block Out
11	1017182	Shaft, Traction Wheel	29	D1166	Hair Pin, 3/32" dia. x 2" long
12	1017161	Slide Guide Strip	30	1036008	Band, Connecting 16" x 48"
13	3090L1	Bearing, 4-Bolt Flange, 2 7/16"	31	1022554	Weights, 50 lbs. (23 kg) ea.
14	2214C	Bearing, 4-bolt flange, 2" bore	32	1017181	Key, 3/4" sq. x 4" long
15	41600	Keeper Kit f/ Winch K1550	33	1017144	Key, 7/8" sq. x 5" long
16	1012785	Decal, Chain Travel	34	1025754	Slide Weldment
17	1002301	Decal, Caution - General Operator	35	1025653	Leveler Plate
18	1012872	Decal, Danger Do Not Operate...			

Item No. 2 (Cover Top Panel) is attached using:
33060 – 3/8" x 1" Bolts, 33024 – 3/8" Flat Washers,
33136 – 3/8" Nylon Lock Nuts

Item No. 3 (Inspection Door) is attached using:
33294 – 1/2" x 1" Bolts, 33025 – 1/2" Flat Washers,
33138 – 1/2" Nylon Locknuts

Item No. 4 (Winch) is attached using:
33060 – 3/8" x 1" Bolts, 33024 – 3/8" Flat Washers,
33136 – 3/8" Nylon Locknuts

Item No. 5 (Tube Section) is attached to
the Inspection Corner using:
33060 – 3/8" x 1" Bolts, D1150 – 3/8" Lock Washers,
33136 – 3/8" Nylon Locknuts

Item No. 8 (Hole Cover) is attached using:
1018332 – 3/8" Wingnut

Item No. 12 (Guide Straps) are attached using:
1002243 – 1/2" x 1 1/2" Carriage Bolts,
33138 – 1/2" Nylon Locknuts

Item No. 13 (Bearings) are attached using:
D1171 – 5/8" Lock Washers,
D1170 – 5/8" Non-Lock Nuts

Item No. 14 (Bearings) are attached using:
33244 – 5/8" x 2" Bolts, D1171 – 5/8" Lock Washers,
D1170 – 5/8" Non-Lock Nuts

Item No. 20 (Slide Lift Straps) are attached to
Slide Weldments using:
33244 – 5/8" x 2" Bolts,
33139 – 5/8" Nylon Locknuts

Item No. 23 (Pulley Sides) are attached to
Pulley using:
1002228 – 1/2" x 2" Bolts,
33138 – 1/2" Nylon Locknuts

Item No. 24 (Pulley) is attached to Pulley
Bracket using:
1002229 – 1/2" x 2 1/2" Bolts,
33138 – 1/2" Nylon Locknuts

Item No. 31 (Weights) are secured from sliding
off support bar using:
33310 – 3/8" x 1 1/2" Bolts,
33136 – 3/8" Nylon Locknuts

Item No. 35 (Leveler Plate) is attached using:
33244 – 5/8" x 2" Bolts,
33139 – 5/8" Nylon Locknuts

PARTS LIST

DRIVE CORNER ASSEMBLY

100 HP (75 kw)

Standard Drive Corner

This drive corner is always located above the Inspection Corner.

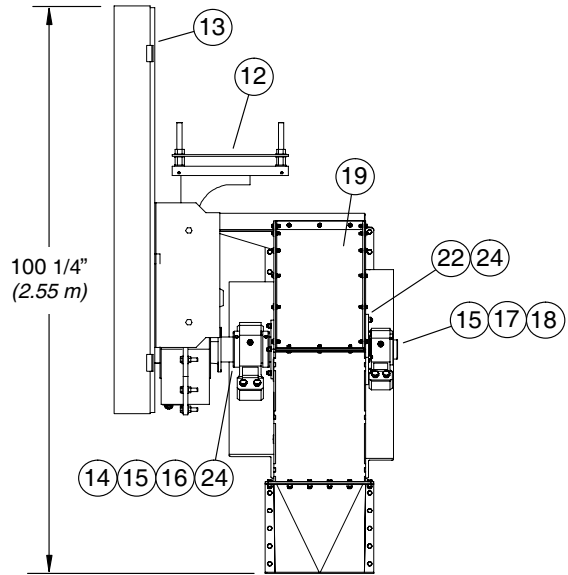
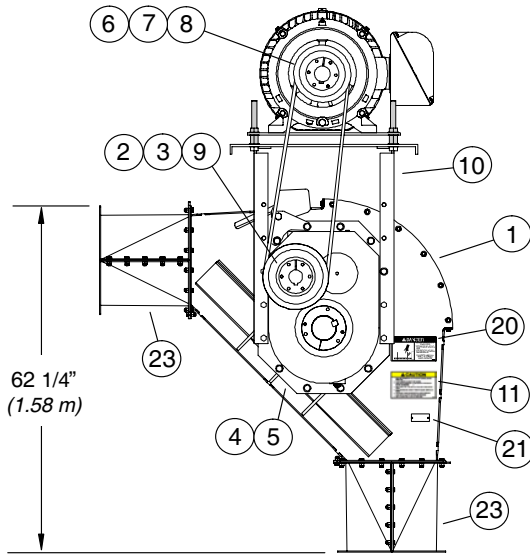

Reversed Drive Corner

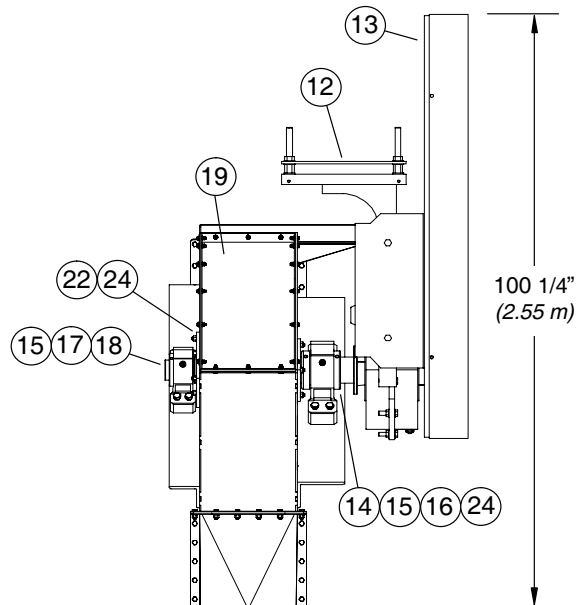
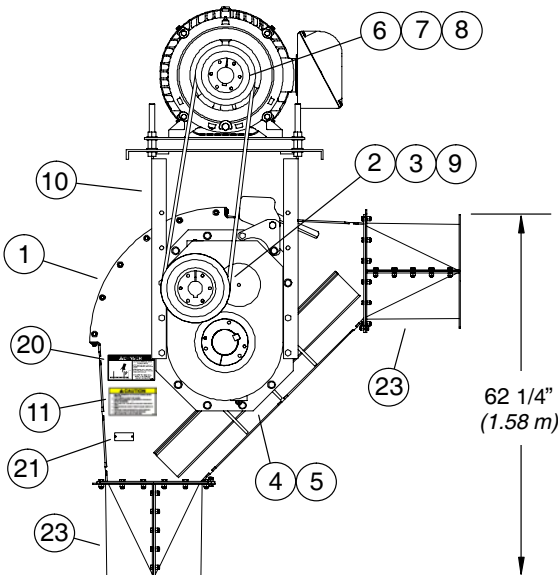

The reversed drive corner (left drive corner) has the same components as the standard drive corner, the only difference is the housing. The housing for the reversed drive corner was designed so all components could be mounted on the opposite side of the housing as compared to the standard drive corner.

The regular drive corner and the reversed drive corner can be switched to put the belt guard (drive motor) on a particular side of the loop.

DRIVE CORNER ASSEMBLY

100 HP (75 kw)

Ref. No.	Part No.	Description	Ref. No.	Part No.	Description
1	1036846	Drive Corner, right (100 hp)	13	1036915	Belt Guard f/ 100 hp motor
(1)	1036847	Drive Corner, left (100 hp)	14	1016994	Bearing, Pillow Block, 4 7/16"
2	1036942	Sheave, QD 4B 11.8" 5VX	15	1017021	Seal, f/ 3 7/16" Bearing
3	3052L1	Bushing, QD Style E, 2 7/16"	16	1016987	Shaft
4	1036849	Gear Reducer, TA8407H25	17	1016995	Bearing, Pillow Block, 3 7/16"
5	1036850	Kit, Bushing (f/ Reducer)	18	1025658	Sprocket, 19 tooth
6	1036941	Sheave, QD 4B 10.3" 5VX	19	1016983	Cover, f/ Grain Pump Corner
7	1036943	Bushing, QD Style E 2 7/8"	20	1012872	Decal, Danger, Do Not Operate...
8	1036944	Belt, B-112 5VX	21	34687	Serial Plate
9	1036851	Fan, Reducer Cooling	22	1016993	Key, 1" sq. x 6" long
10	1036914	Bracket, Reducer Mount	23	1036855	Square-to-Round Weldment
11	1002301	Decal, Caution General Operator	24	1017022	Seal f/ 4 7/16" Bearing
12	1036852	Mount, Motor	25	1033567	Bearing Stop

The Complete Drive Corner (right) can be Obtained
by Ordering: Part No. 1036845

The Complete Drive Corner (left) can be Obtained
by Ordering: Part No. 1036847

Item No. 10 (Reducer Bracket) is attached using:
33112 – 3/4" x 3" Bolt, 33027 – 3/4" Flat Washer,
33140 – 3/4" Nylon Locknut

Item No. 14 (Bearing) is attached using:
33277 – 3/4" x 4 1/2" Bolts, D1153 – 3/4" Lock Washer,
D1152 – 3/4" Non-Lock Nut

Item No's. 15 & 24 (Seal Plates) are attached using:
1002227 – 1/2" x 1 1/2" Bolts,
33138 – 1/2" Nylon Locknut

Item No. 17 (Bearing) is attached using:
33250 – 3/4" x 4" Bolts, D1153 – 3/4" Lock Washer,
D1152 – 3/4" Non-Lock Nut

Item No. 20 (Cover) is attached using:
33229 – 3/8" x 1 1/4" Bolts, 33024 – 3/8" Flat Washers
D1150 – 3/8" Lock Washer, D1149 – 3/8" Non-Lock Nut

Item No. 23 (Square to Round Weldments) are
attached to the Drive Corner using:
33082 – 1/2" x 1 1/4" Bolts,
33138 – 1/2" Nylon Locknuts

Item No. 23 (Square to Round Weldment Halves)
are attached to each other:
33082 – 1/2" x 1 1/4" Bolts,
33138 – 1/2" Nylon Locknuts

PARTS LIST

DRIVE CORNER ASSEMBLY

125 HP (90 kw)

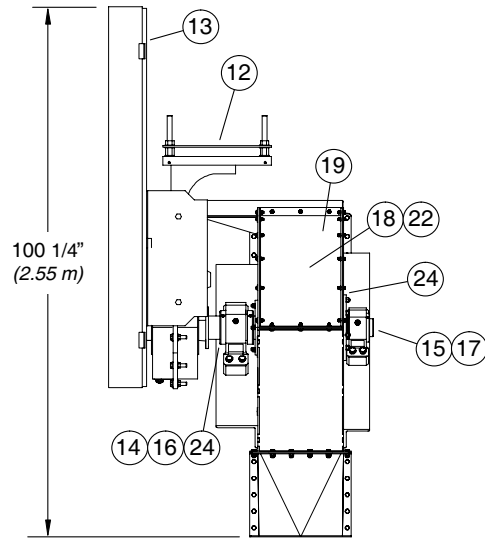
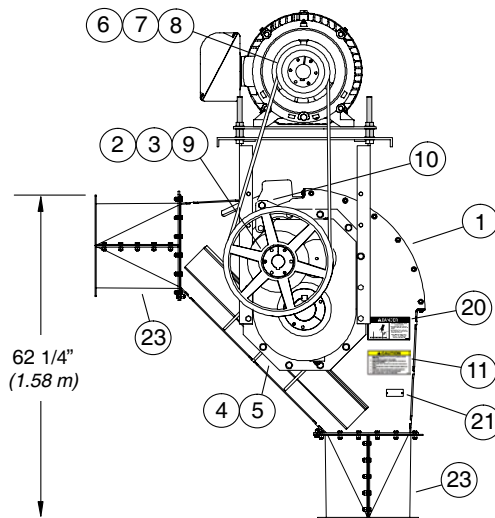

Ref. No.	Part No.	Description
1	1036846	Drive Corner (125 hp)
2	1035375	Sheave, QD 4B 21.2" 5VX
3	3052L1	Bushing, QD Style E, 2 7/16"
4	1044746	Gear Reducer, TA8407H15
5	1036850	Kit, Bushing (f/ Reducer)
6	1033979	Sheave, 5VX 4B 11.3" 5V1134
7	1044754	Bushing, QD Style E 3 3/8"
8	1044755	Belt, B-132 5VX
9	1036851	Fan, Reducer Cooling
10	1036914	Bracket, Reducer Mount
11	1002301	Decal, Caution General Operator
12	1044745	Mount, Motor

Ref. No.	Part No.	Description
13	1036915	Belt Guard f/ 125 hp motor
14	1016994	Bearing, Pillow Block, 4 7/16"
15	1017021	Seal, f/ 3 7/16" Bearing
16	1016987	Shaft
17	1016995	Bearing, Pillow Block, 3 7/16"
18	1025658	Sprocket, 19 tooth
19	1016983	Cover, f/ Grain Pump Corner
20	1012872	Decal, Danger, Do Not Operate...
21	34687	Serial Plate
22	1016993	Key, 1" sq. x 6" long
23	1036855	Square-to-Round Weldment
24	1017022	Seal f/ 4 7/16" Bearing

The Complete Drive Corner can be Obtained by Ordering: Part No. 1044720

Item No. 10 (Reducer Bracket) is attached using:
 33112 – 3/4" x 3" Bolt, 33027 – 3/4" Flat Washer,
 33140 – 3/4" Nylon Locknut

Item No. 14 (Bearing) is attached using:
 33277 – 3/4" x 4 1/2" Bolts, D1153 – 3/4" Lock Washer,
 D1152 – 3/4" Non-Lock Nut

Item No's. 15 & 24 (Seal Plates) are attached using:
 1002227 – 1/2" x 1 1/2" Bolts,
 33138 – 1/2" Nylon Locknut

Item No. 17 (Bearing) is attached using:
 33250 – 3/4" x 4" Bolts, D1153 – 3/4" Lock Washer,
 D1152 – 3/4" Non-Lock Nut

Item No. 20 (Cover) is attached using:
 33229 – 3/8" x 1 1/4" Bolts, 33024 – 3/8" Flat Washers
 D1150 – 3/8" Lock Washer, D1149 – 3/8" Non-Lock Nut

Item No. 23 (Square to Round Weldments) are attached to the Drive Corner using:
 33082 – 1/2" x 1 1/4" Bolts,
 33138 – 1/2" Nylon Locknuts

Item No. 23 (Square to Round Weldment Halves) are attached to each other:
 33082 – 1/2" x 1 1/4" Bolts,
 33138 – 1/2" Nylon Locknuts

STANDARD CORNER ASSEMBLY

f/ 100 H.P. & 125 H.P.

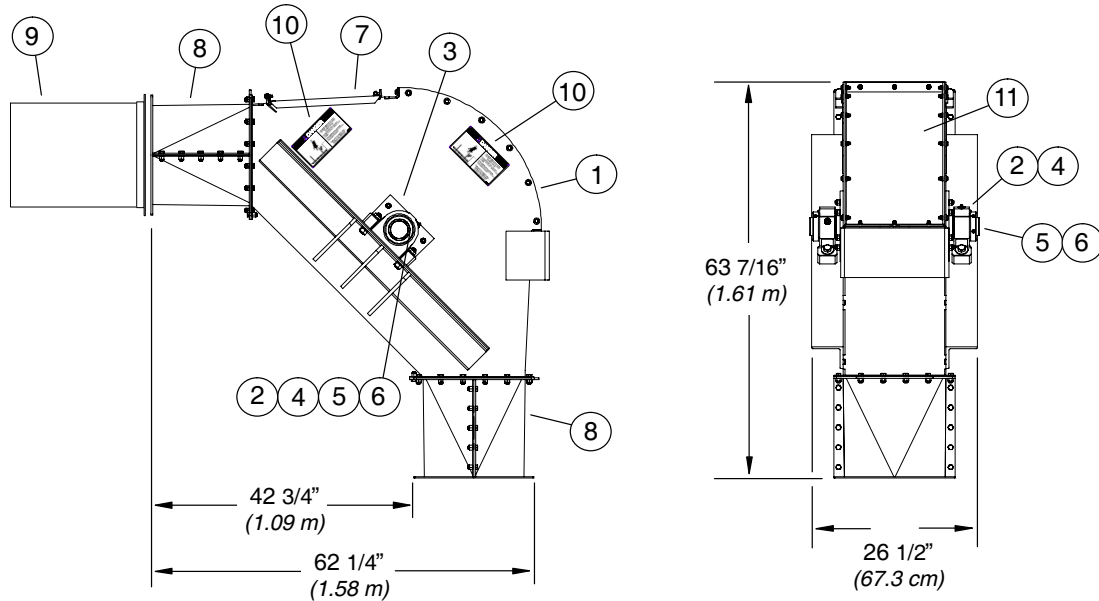

Ref. No.	Part No.	Description
1	1036921	Corner Weldment, 90°
2	1025681	Bearing, Pillow Block, 2 15/16"
3	1025726	Seal, f/ 2 15/16" Bearing
4	1025659	Sprocket, 19 tooth
5	1017144	Key, 7/8" sq, x 5" long
6	1025705	Shaft

Item No. 2 (Bearings) are attached using:
 33295 – 3/4" x 3 1/2" Bolts, 33027 – 3/4" Flat Washers,
 D1153 – 3/4" Lock Washers, D1152 – 3/4" Non-Lock Nuts

Item No. 3 (Seals) are attached using:
 1002227 – 1/2" x 1 1/2" Bolts, 33138 – 1/2" Nylon Locknuts

Item No. 7 (Access Door) is attached using:
 33046 – 5/16" x 1" Bolts, 33135 – 5/16" Nylon Locknuts,
 33024 – 3/8" Flat Washers, D1150 – 3/8" Lock Washers,
 D1149 – 3/8" Non-Lock Nuts

Ref. No.	Part No.	Description
7	1018326	Door, Access
8	1036855	Square-to-Round, 16"
9	1035961	Tube Section w/ Flange
10	1012872	Decal, Danger Do Not Operate...
11	1016983	Cover f/ Grain Pump Corner

Item No. 8 (Square to Round Weldment Halves) are attached together and to the Corner using:
 33082 – 1/2" x 1 1/4" Bolts,
 33138 – 1/2" Nylon Locknuts

Item No. 11 (Cover) is attached using:
 33229 – 3/8" x 1 1/4" Bolts, 33024 – 3/8" Flat Washer,
 D1150 – 3/8" Lock Washer, D1149 – 3/8" Non-Lock Nut

PARTS LIST

90° DISCHARGE w/ GATE (DROP ASSEMBLY)

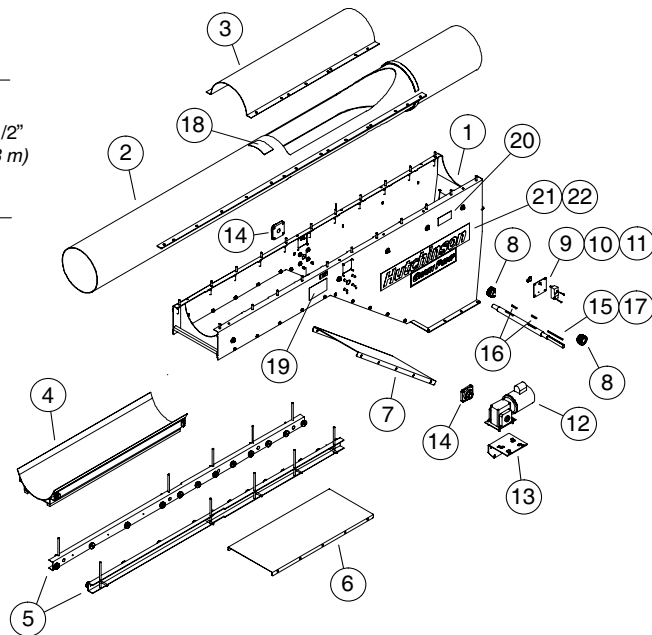
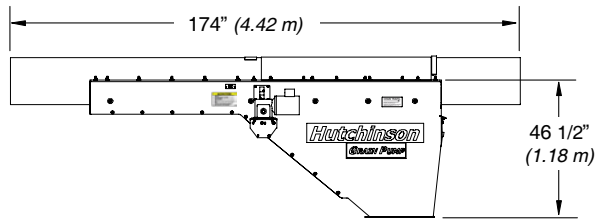

Ref. No.	Part No.	Description
1	1040973	Drop Weldment, 90°
2	1040971	Tube Weldment
3	1025771	Cover f/ Drop Tube Cutout
4	1025750	Drop Gate Weldment
5	1016844	Side Roller Rail (left)
(5)	1017041	Side Roller Rail (right)
6	1016852	Door, Access
7	1017043	Rear Access Panel
8	1016854	Spur Gear, S22 x 1.50
9	1017199	Lever Arm f/ Limit Switch
10	1017102	Plate, Mounting (f/ limit switch)
11	1017007	Limit Switch, Square-D
12	1026526	Motor, 1/2 HP, 3 PH 208-230/460 volt, 60 HZ

Ref. No.	Part No.	Description
(12)	1026528	Motor, 1/2 HP, Explosion Proof 3 PH, 208-230/460 volt, 50/60 HZ
13	1040975	Plate, Mount f/ electric motor
14	8370C	Bearing, 4-hole flange 1 1/4" bore
15	1034206	Pinion Shaft
16	1038D	Key, 3/8" sq. x 2" long
17	- - -	Key, supplied with motor, Item 12
18	1012872	Decal, Danger, Do Not Operate...
19	1002301	Decal, Caution, General Operator
20	1012785	Decal, Chain Travel
21	1001127	Decal, Hutchinson
22	34349	Decal, Grain Pump

CHAIN & PADDLES ASSEMBLY

Ref. No.	Part No.	Description
1	1016969	Paddle, 5/8" UHMW
2	1025713	Chain, WH124, 36 pitch 144" (3.66 m) long
3	33310	Bolt, 3/8"-16 x 1 1/2"
4	1044656	Rubber Clean-Out f/ Paddle (Optional)
5	1002199	Bolt, 3/8-16 x 2" (when optional rubber clean-out is used)
6	33024	Washer, 3/8" Flat
7	33136	Nut, 3/8"-16 Nylon Lock
8	1017239	Pin, Connecting, w/ Double Flat End
(8)	1047405	Pin, Connecting, w/ Full Round End
9	1017240	Keeper f/ Connecting Pin

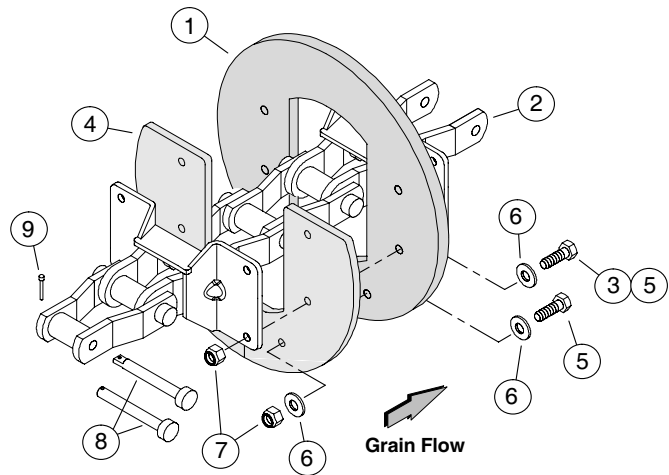

GROUND CONTROL WHEEL KIT (w/ CHAIN)

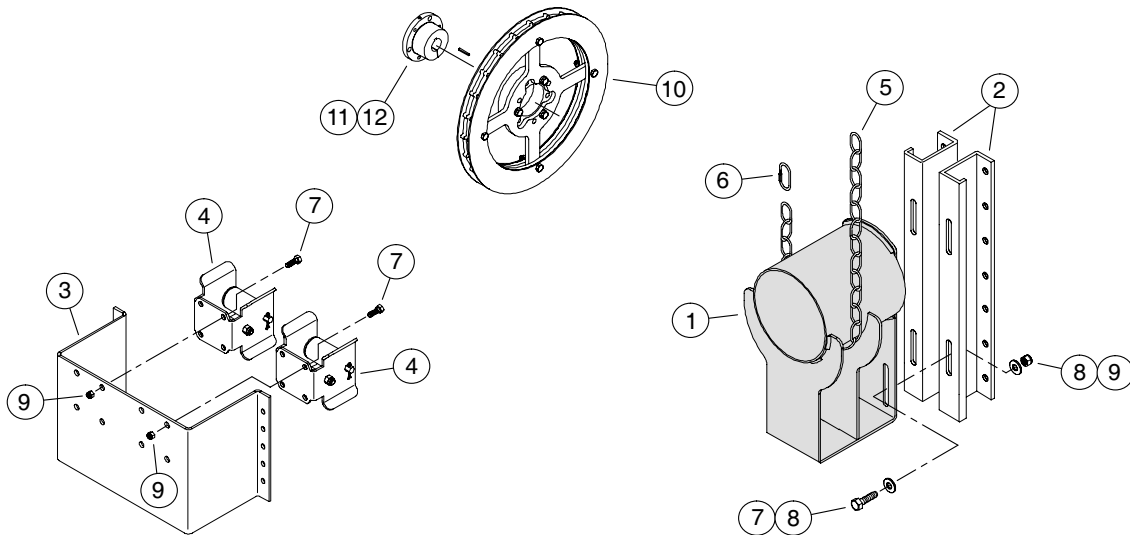

Ref. No.	Part No.	Description
1	1042186	Mount, Lower Chain
2	1011743	Plate, Bin Wall Mount
3	1042178	Bracket, Upper Wall
4	1042174	Roller Assembly
5	1042193	Chain, 3/16" x 120' long
6	1042190	Coupler, Threaded Chain

Ref. No.	Part No.	Description
7	33060	Bolt, 3/8-16 x 1" G5 PLT
8	33024	Washer, 3/8" Flat PLT
9	33136	Nut, 3/8-16 Nylon Lock PLT
10	1042153	Chain Wheel Ay. (Sprocket)
11	1036838	Bushing, 1" SF QD
12	4046A1	Key, 1/4" sq. x 3" long

PARTS LIST

GROUND CONTROL WHEEL (w/ CABLE)

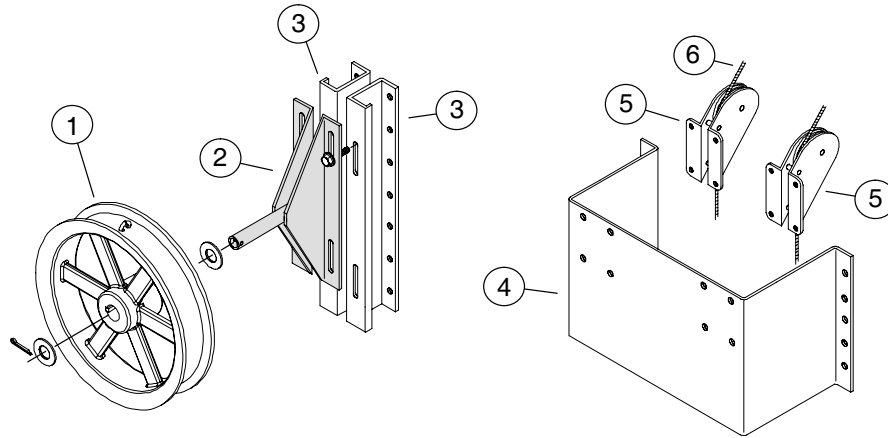

Ref. No.	Part No.	Description	Ref. No.	Part No.	Description
1	1034255	Control Wheel, 2 9/16" wide	4	1011742	Bracket, Upper Wall
2	1011745	Bracket, Wheel Support	5	1006876	Pulley, 2 1/2"
3	1011743	Plate, Binwall Mount	6	1025845	Cable, 1/4" dia. x 150' long

INSPECTION PORT

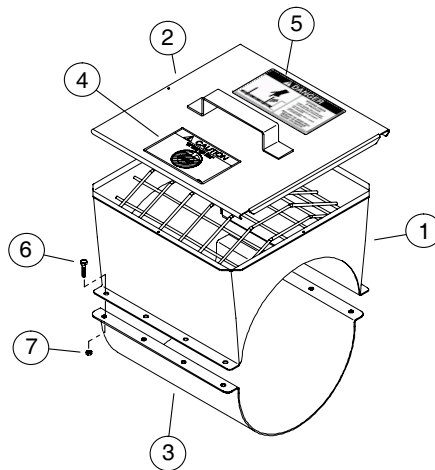
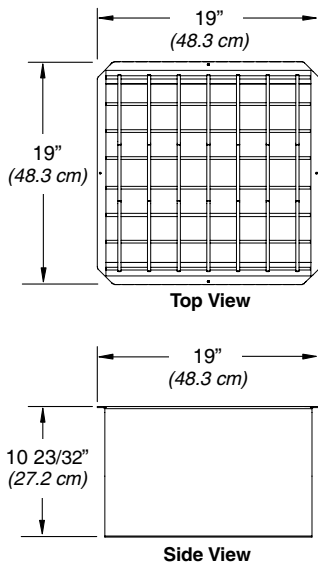

Ref. No.	Part No.	Description
1	11039492	Inspection Port w/ Screen
2	1039495	Cover Weldment
3	1034164	Back Band, 12" x 14"
4	1033033	Decal, Caution, Grain Fill
5	1012872	Decal, Danger, Do Not Operate...
6	4736	Bolt, 5/16-18 x 1 1/2"
7	33151	Nut, 5/16-18 Non-Lock

DUMP HOPPER (7 GRATE) w/ ELECTRIC RACK & PINION GATES

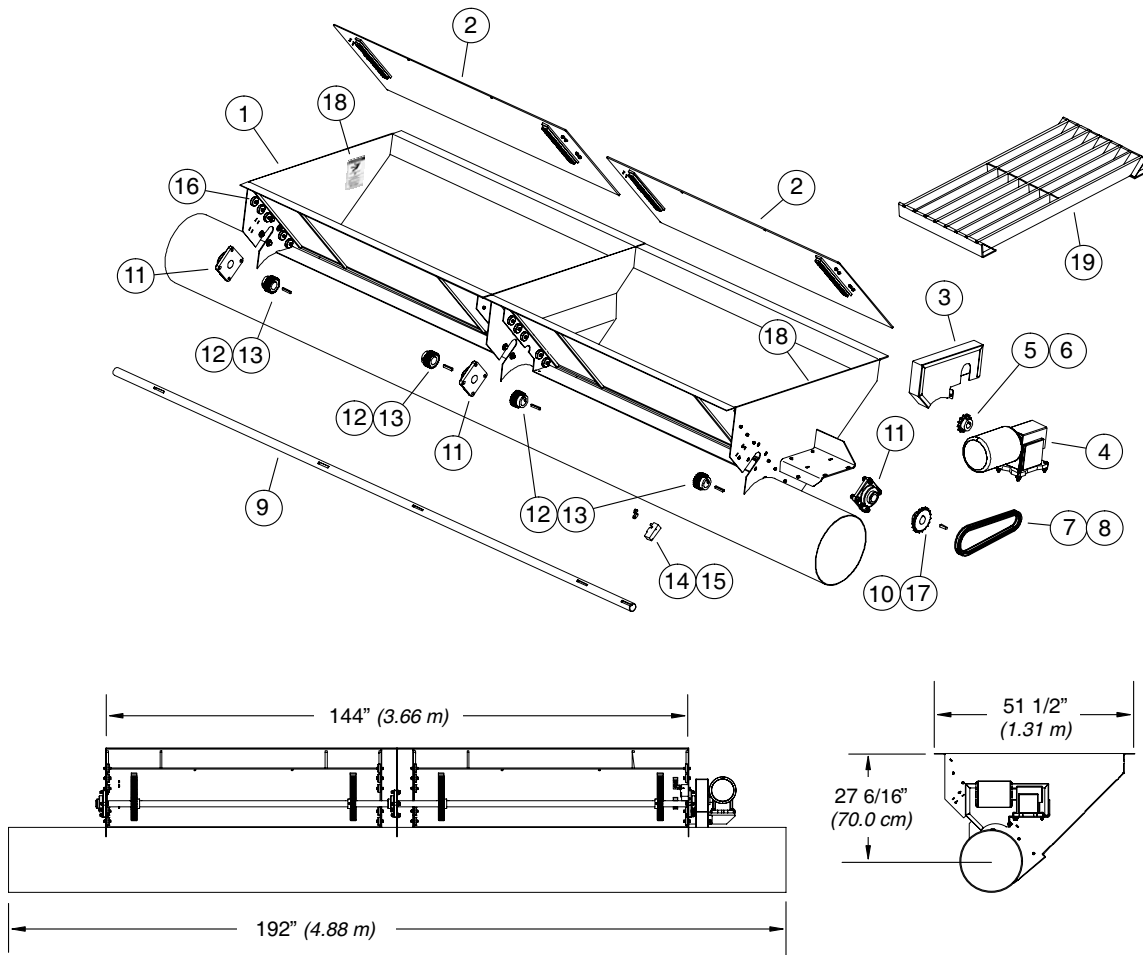

The complete hopper assembly can be obtained by ordering Part No's. 1040939, 1040939EP
The complete hopper assembly includes all items listed below.

Ref. No.	Part No.	Description	Ref. No.	Part No.	Description
1	1040940	Hopper Weldment, 7 Grate Dump	10	41069	Sprocket, 60B 19 tooth
2	1025760	Gate f/ 7 Grate Dump Hopper	11	1010A	Bearing, 4-Hole Flange, 1 1/2"
3	1034157	Guard, Chain	12	1016854	Spur Gear, S822 x 1 1/2" KW&SS
4	1014757	Motor, 1/2 H.P. 108-230V	13	1038D	Key, 3/8" sq. x 2" long
(4)	1017557	Motor, 1/2 H.P. 108-230V Exp. Proof	14	1017007A	Limit Switch
5	1034145	Sprocket, 60B 13 tooth	15	1017199	Lever Arm f/ Limit Switch
6	5169B1	Key, 1/4" sq. x 1 1/4" long	16	1016845	Skate Wheel
7	40975	Chain, RC-60 50 pitch	17	4049A1	Key, 3/8" sq. x 1 1/2" long
8	- - -	•Connecting Link f/ RC-60 Chain	18	1002310	Decal, Danger: Cover Missing
9	1040952	Pinion Shaft f/ 7 Grate Dump Hopper	19	1038438	Grate f/ Dump Hopper

• Indented Parts Names Indicate these Parts are Included in the Previous Assembly.

PARTS LIST

FLAT STORAGE WELL **w/ ELECTRIC SLIDE GATE**

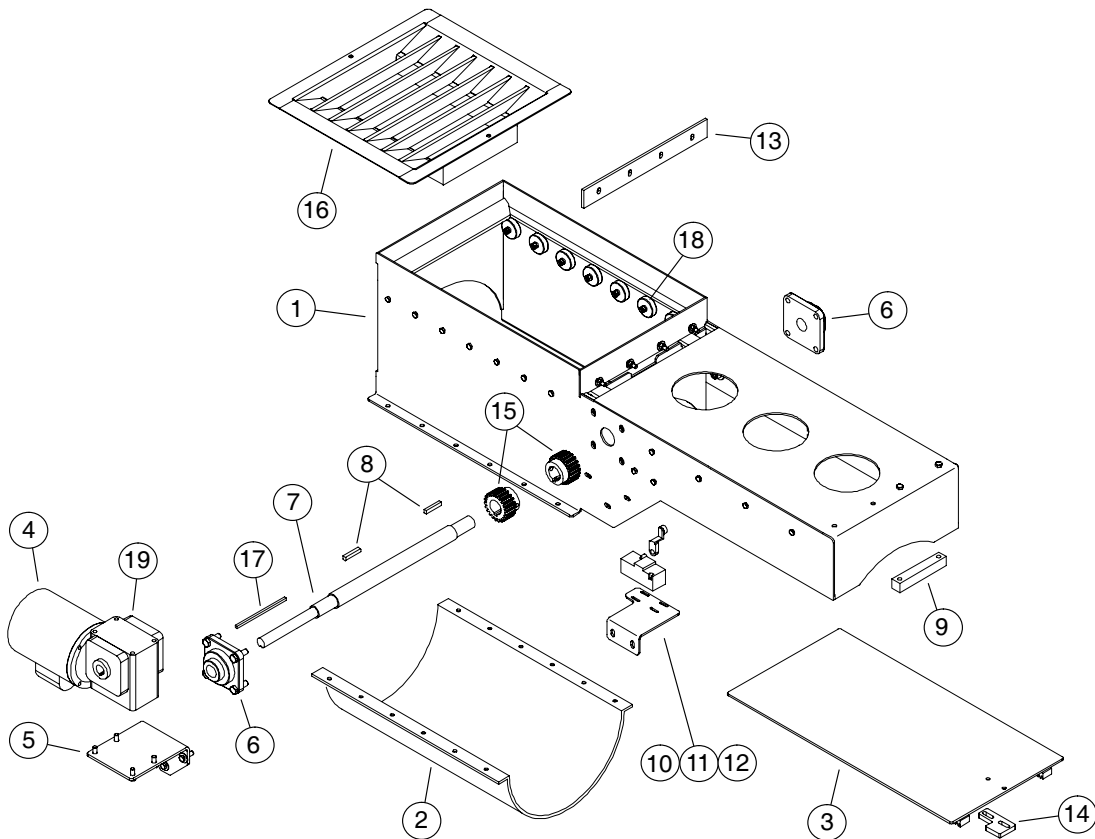

Ref. No.	Part No.	Description	Ref. No.	Part No.	Description
1	1041126	Flat Storage Well Weldment	9	1016547	Gate Stop f/ Flat Storage Well
2	1017312	Binwell Band	10	1017007	Limit Switch, Square-D
3	1041114	Gate f/ Flat Storage Well	11	1017199	Lever Arm f/ Limit Switch
4	1026526	Motor, 1/2 hp, 3 PH 208-230/460 volt 60 HZ	12	1041112	Mount Plate f/ Limit Switch
(4)	1026528	Motor, 1/2 HP Explosion Proof 3 PH, 208-230/460 volt, 50/60 HZ	13	1017137	Wiper Seal, UHMW
5	1034221	Plate, Electric Motor Mount	14	1041075	Stop, Closed Position
6	8370C	Bearing, 4-Hole Flange 1 1/4"	15	1016854	Spur Gear, S822 x 1 1/2"
7	1034220	Shaft f/ Flat Well Storage	16	1040977	Grate f/ 16" Flat Storage Well
8	1038D	Key, 3/8" sq. x 2" long	17	- - -	Key, supplied with Item 4
			18	1016845	Skate Wheel
			19	1023415	Gearbox, HMQ621-60-H-56C-16

The complete Flat Storage Well assembly can be obtained by ordering:
Part No's. 1040976, 1040976EP

The complete well assembly includes all items listed above.

CHAIN MAINTENANCE ACCESS HOPPER 6' LONG HORIZONTAL

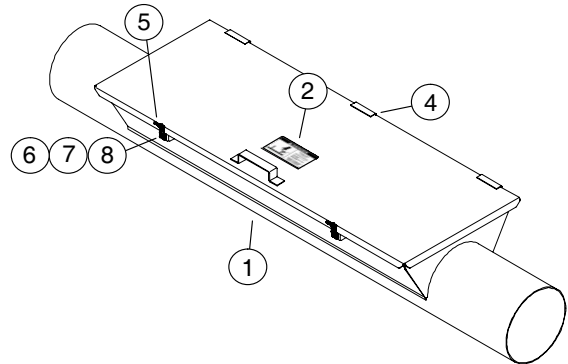
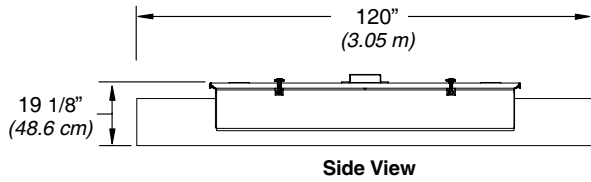
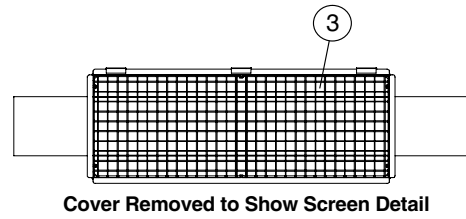
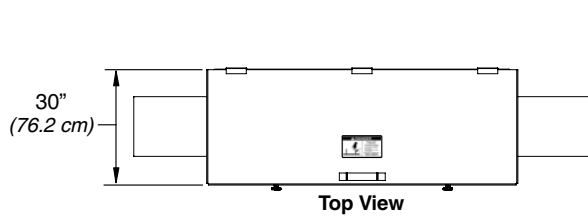

Item No. 3 (Screen Weldment) is attached using:
33229 – 3/8-16 x 1 1/4" Bolts,
D1150 – 3/8" Lock Washers
D1149 – 3/8" Non-Lock Nuts

Complete Assembly f/ 6' Long Hopper - Part No. 1040997

Ref. No.	Part No.	Description	Ref. No.	Part No.	Description
1	1040998	Chain Access Weldment	5	1018308	Rubber Latch f/ Chain Access
2	1012872	Decal, Danger: Do Not Operate..	6	1018271	Bolt, #6 x 3/8" PPH, PLT
3	1041003	Screen f/ Chain Access	7	1018272	Washer, #6 Lock PLT
4	4000A1	Hinge, 1/4" pin x 4" long	8	1018273	Nut, #6 Non-Lock PLT



Hutchinson/Mayrath

A Division of GLOBAL Industries Inc.

Hutchinson/Mayrath • P.O. Box 629 • Clay Center, KS. 67432
Ph. 785-632-2161 • Fx. 785-632-5964 • Toll Free 800-523-6993
www.hutchinson-mayrath.com